

EC-B SERIES

Related Information

- General terms and conditions..... F-17
- Selection guide P.1075~
- Glossary of terms..... P.1401
- General precautions P.1405

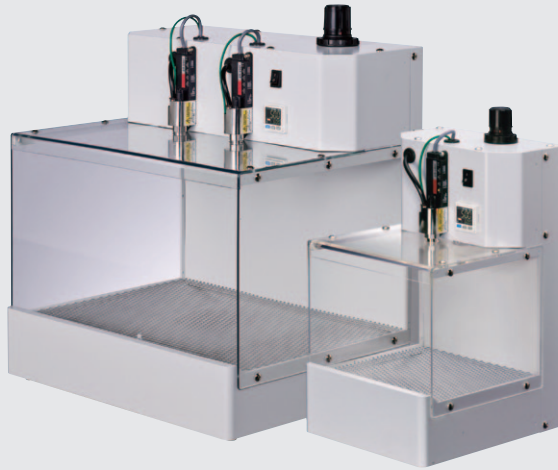

panasonic-electric-works.net/sunx

- FIBER SENSORS
- LASER SENSORS
- PHOTOELECTRIC SENSORS
- MICRO PHOTOELECTRIC SENSORS
- AREA SENSORS
- LIGHT CURTAINS
- PRESSURE / FLOW SENSORS
- INDUCTIVE PROXIMITY SENSORS
- PARTICULAR USE SENSORS
- SENSOR OPTIONS
- SIMPLE WIRE- SAVING UNITS
- WIRE- SAVING SYSTEMS
- MEASUREMENT SENSORS

STATIC CONTROL DEVICES

- ENDOSCOPE
- LASER MARKERS
- PLC / TERMINALS
- HUMAN MACHINE INTERFACES
- ENERGY CONSUMPTION VISUALIZATION COMPONENTS
- FA COMPONENTS
- MACHINE VISION SYSTEMS
- UV CURING SYSTEMS

- Selection Guide
- Static Removers
- Cleaning Box
- Pluse Air-gun
- Electrostatic Sensor

Compact dust collection and removal features

Direct ion / pulsed air emission



Direct ion emission paired with pulsed air emission provides quick and effective removal of static charges along with any dust that is present on the part.

White LED illumination





The white LED illuminates the work piece to ensure complete dust removal.

Dust collecting fan



A powerful dust collecting fan exhausts dust quickly, preventing re-adhesion of dust.

ORDER GUIDE

Type	Appearance	Charge removal time ($\pm 1,000$ V \rightarrow ± 100 V)	Ion balance	Model No.
200 mm 7.874 in width type		0.5 sec. approx or less (Note)	± 10 V or less	EC-B01-EX
400 mm 15.748 in width type				

Note: Typical value at 100 mm **3.937 in** from the front of air outlet at an applied air pressure of 0.50 MPa.

OPTIONS

Type	Model No.	Description	
Duct flange	EC-BD50	For $\varnothing 50$ mm 1.969 in duct flange	A flange that connects a duct hose for air exhaust to the EC-B main body
	EC-BD76	For $\varnothing 76$ mm 2.992 in duct flange	
Air filter	EC-BFX3	For EC-B01-EX	Replacement filter (3 pcs. per set)
	EC-B2FX3	For EC-B02-EX	
Spot nozzle	EC-BAS	Exclusive nozzle for EC-B02-EX	Ionized air can be collected around the center. (2 pcs. per set)

SPECIFICATIONS

Item	Type	200 mm 7.874 in width type	400 mm 15.748 in width type
	Model No.	EC-B01-EX	EC-B02-EX
Charge removal time ($\pm 1,000$ V \rightarrow ± 100 V)		0.5 sec. approx. or less (Note 1)	
Ion balance		± 10 V or less	
Applicable fluid		Air (dried clean air)	
Supplied air flow		Max. 300 ℓ /min. (ANR) or less	Max. 500 ℓ /min. (ANR) or less
Air pressure range		0.05 to 0.50 MPa	
Power supply voltage		Accessory AC adapter (Note 2) INPUT: 100 to 240 V AC ± 10 % 50/60 Hz (OUTPUT: 24 V DC)	
Power consumption		80 VA or less	90 VA or less
Timer mode		2 sec. / 5 sec. / 10 sec. / synchronized with sensor or with external input selectable by switch	
Pulse air mode		Pulse 1 (long) / Pulse 2 (short) / OFF (continuous) selectable by switch	
Net weight		Main body: 6.5 kg approx.	Main body: 13 kg approx.

Notes: 1) Typical value at 100 mm **3.937 in** from the front of air outlet at an applied air pressure of 0.50 MPa.

2) Please prepare an AC cable separately as it is needed.

The following cables are available as optional:

CN-ACCN-C2: AC cable (conforming to CCC), **CN-ACKR-C2**: AC cable (conforming to KTL)

FIBER
SENSORSLASER
SENSORSPHOTO-
ELECTRIC
SENSORSMICRO
PHOTO-
ELECTRIC
SENSORSAREA
SENSORSLIGHT
CURTAINSPRESSURE /
FLOW
SENSORSINDUCTIVE
PROXIMITY
SENSORSPARTICULAR
USE
SENSORSSENSOR
OPTIONSSIMPLE
WIRE-SAVING
UNITSWIRE-SAVING
SYSTEMSMEASURE-
MENT
SENSORSSTATIC
CONTROL
DEVICES

ENDOSCOPE

LASER
MARKERSPLC /
TERMINALSHUMAN
MACHINE
INTERFACESENERGY
CONSUMPTION
VISUALIZATION
COMPONENTSFA
COMPONENTSMACHINE
VISION
SYSTEMSUV
CURING
SYSTEMSSelection
GuideStatic
RemoversCleaning
BoxPulse
Air-gunElectrostatic
Sensor**EC-B**

PRECAUTIONS FOR PROPER USE



- Never use this product in a device for personnel protection.
- In case of using sensing devices for personnel protection, use products which meet laws and standards, such as OSHA, ANSI or IEC etc., for personnel protection applicable in each region or country.
- Do not use this product in places where there may be danger of flammable or combustible items being present.

DIMENSIONS (Unit: mm in)

The CAD data in the dimensions can be downloaded from our website.

EC-B01-EX

Cleaning box

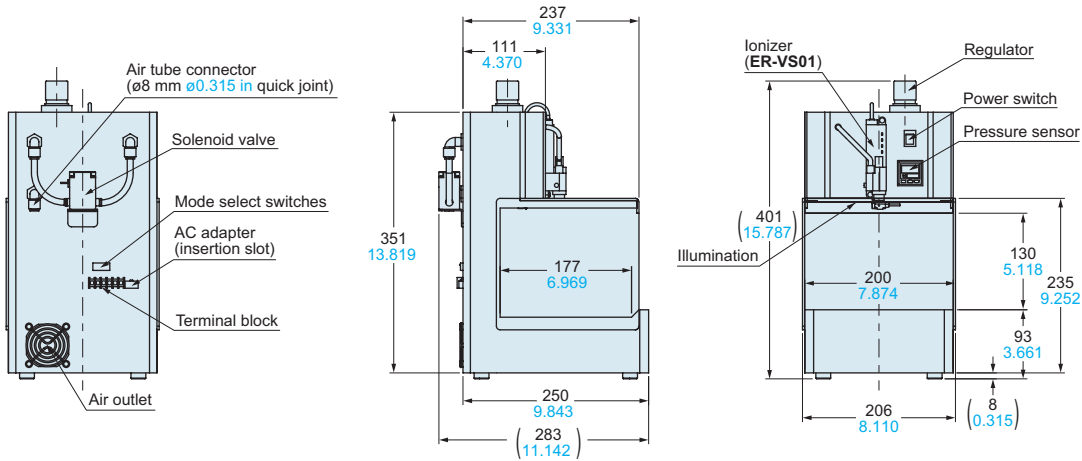

EC-B02-EX

Cleaning box

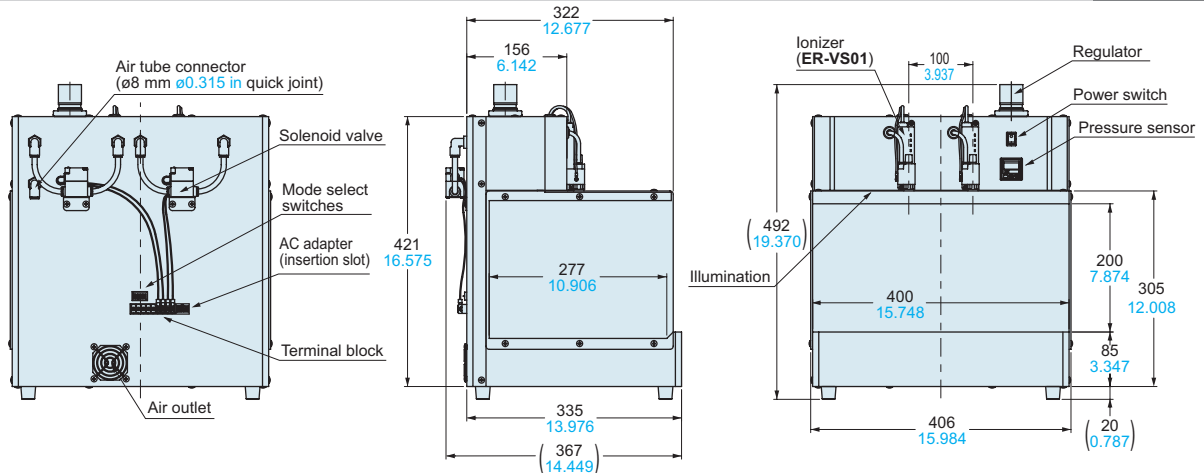

- FIBER SENSORS
- LASER SENSORS
- PHOTO-ELECTRIC SENSORS
- MICRO PHOTO-ELECTRIC SENSORS
- AREA SENSORS
- LIGHT CURTAINS
- PRESSURE / FLOW SENSORS
- INDUCTIVE PROXIMITY SENSORS
- PARTICULAR USE SENSORS
- SENSOR OPTIONS
- SIMPLE WIRE-SAVING UNITS
- WIRE-SAVING SYSTEMS
- MEASUREMENT SENSORS
- STATIC CONTROL DEVICES
- ENDOSCOPE
- LASER MARKERS
- PLC / TERMINALS
- HUMAN MACHINE INTERFACES
- ENERGY CONSUMPTION VISUALIZATION COMPONENTS
- FA COMPONENTS
- MACHINE VISION SYSTEMS
- UV CURING SYSTEMS
- Selection Guide
- Static Removers
- Cleaning Box
- Pluse Air-gun
- Electrostatic Sensor

MEMO

