

- FIBER SENSORS
- LASER SENSORS
- PHOTOELECTRIC SENSORS
- MICRO PHOTOELECTRIC SENSORS
- AREA SENSORS
- LIGHT CURTAINS
- PRESSURE / FLOW SENSORS
- INDUCTIVE PROXIMITY SENSORS
- PARTICULAR USE SENSORS
- SENSOR OPTIONS
- SIMPLE WIRE- SAVING UNITS
- WIRE- SAVING SYSTEMS
- MEASUREMENT SENSORS
- STATIC CONTROL DEVICES
- ENDOSCOPE
- LASER MARKERS
- PLC / TERMINALS
- HUMAN MACHINE INTERFACES
- ENERGY CONSUMPTION VISUALIZATION COMPONENTS
- FA COMPONENTS
- MACHINE VISION SYSTEMS
- UV CURING SYSTEMS
- Selection Guide
- Laser Displacement
- Magnetic Displacement
- Collimated Beam
- Digital Panel Controller
- Metal-sheet
- Double-feed Detection

Related Information

■ General terms and conditions..... F-17

■ General precautions..... P.1405



panasonic-electric-works.net/sunx



- Never use this product in a device for personnel protection.
- In case of using devices for personnel protection, use products which meet laws and standards, such as OSHA, ANSI or IEC etc., for personnel protection applicable in each region or country.

Convenient functions packed in a small body!

Ultra-compact

Ultra-compact size of W48 × H24 × D65.5 mm
W1.890 × H0.945 × D2.579 in.
 It can be mounted even in a tight space.



Large display

Though the size is compact, the measurement display uses 4 digit, 8 mm **0.315 in** letter height, red 7-segment LEDs.



Incorporates useful functions

“It is troublesome to change threshold value each time...”

▶ Auto-reference function is useful!

This function automatically adds / subtracts the changes to / from the threshold level even if there is a change in the reference pressure.
 So the threshold level does not need to be changed each time.

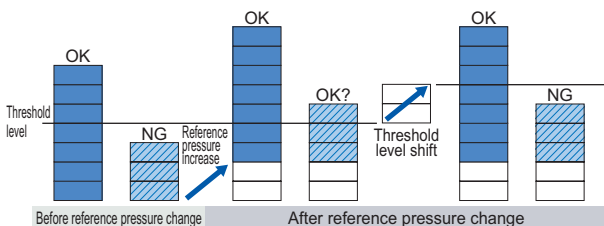

Product can be judged as OK or NG.

Without auto-reference function
 Due to change in reference pressure, even an NG product is judged as an OK product.

With auto-reference function
 If auto-reference input is fed before pressure level judgement, when the reference pressure changes, the threshold levels are automatically changed accordingly and correct judgment is possible.

“I want to measure based on the measured value of the master object.”

▶ Zero-adjust function is useful!

This function forcibly sets the standard measured value as “0”. It is convenient to measure objects based on the standard of the measurement of a master object, such as when judging variations in products.

Application

• Judging object height

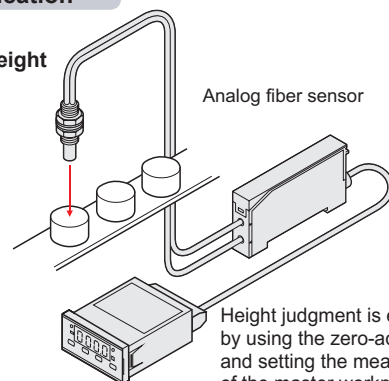

Height judgment is easily done by using the zero-adjust function and setting the measured values of the master workpiece as “0”.

APPLICATIONS

Measuring inner diameter of rings

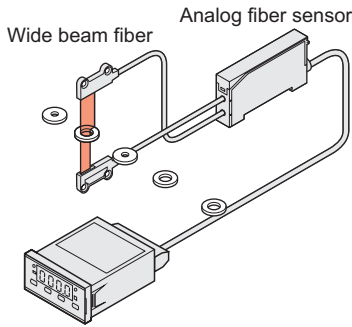

Thickness distinction

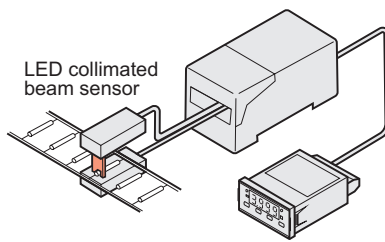

Detecting improper lathe chuck tightening

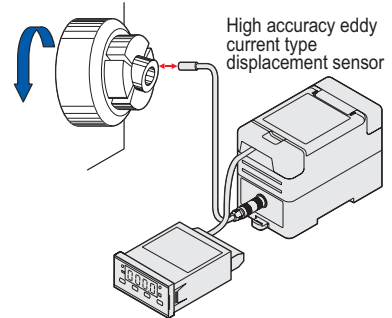

Flexible scaling

The input values can be easily converted into different scales by a key operation. Since the need to convert the displayed value is eliminated, the required information can be confirmed immediately.

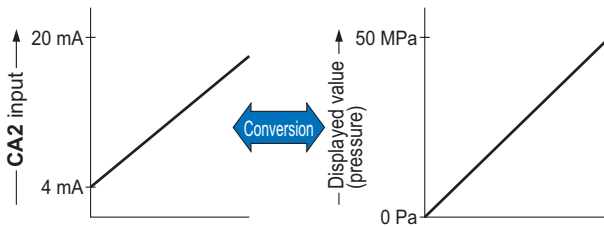

Various input ranges

The CA2 series is provided with 5 types of input ranges: 4 to 20 mA, 1 to 5 V, ±1 V, ±5 V and ±10 V. It can be used with any suitable analog sensor.

Two independent outputs incorporated

Two independent comparative outputs (OUT 1, OUT 2) have been incorporated. High output comparison operation / low output comparison operation can be set for each output. Further, the hysteresis for each of the outputs can be set arbitrarily.

OUT 1: "H", OUT 2: "L"

Independent high and low output comparison operation

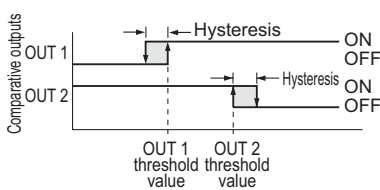

OUT 1: "H", OUT 2: "H"

Independent two high output comparison operation

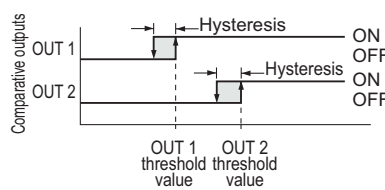

OUT 1: "L", OUT 2: "L"

Independent two low output comparison operation

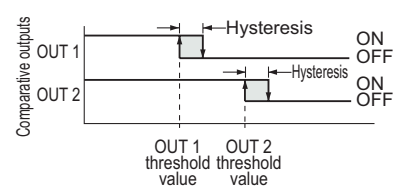

ORDER GUIDE

| Appearance | Input range | Model No. | Output |
|------------|-------------|---------------|-------------------------------|
| | 4 to 20 mA | CA2-T1 | NPN open-collector transistor |
| | 1 to 5 V | CA2-T2 | |
| | ±1 V | CA2-T3 | |
| | ±5 V | CA2-T4 | |
| | ±10 V | CA2-T5 | |

FIBER SENSORS

LASER SENSORS

PHOTOELECTRIC SENSORS

MICRO PHOTOELECTRIC SENSORS

AREA SENSORS

LIGHT CURTAINS

PRESSURE / FLOW SENSORS

INDUCTIVE PROXIMITY SENSORS

PARTICULAR USE SENSORS

SENSOR OPTIONS

SIMPLE WIRE-SAVING UNITS

WIRE-SAVING SYSTEMS

MEASUREMENT SENSORS

STATIC CONTROL DEVICES

ENDOSCOPE

LASER MARKERS

PLC / TERMINALS

HUMAN MACHINE INTERFACES

ENERGY CONSUMPTION VISUALIZATION COMPONENTS

FA COMPONENTS

MACHINE VISION SYSTEMS

UV CURING SYSTEMS

Selection Guide

Laser Displacement

Magnetic Displacement

Collimated Beam

Digital Panel Controller

Metal-sheet Double-feed Detection

CA2

SPECIFICATIONS

| Model No. | CA2-T1 | CA2-T2 | CA2-T3 | CA2-T4 | CA2-T5 |
|---|---|--|--------------|-----------|-----------|
| Item | | | | | |
| Supply voltage | 24 V DC $\pm 10\%$ Ripple P-P 10 % or less | | | | |
| Power consumption | 2.8 W or less | | | | |
| Analog inputs | Input range | 4 to 20 mA | 1 to 5 V | ± 1 V | ± 5 V |
| | Input impedance | 20 Ω | 1 M Ω | | |
| | No. of inputs | 1 No. | | | |
| | Input method | Single end input | | | |
| | A/D conversion method | Successive approximation method | | | |
| | Sampling rate | Selectable from 200 times/sec., 20 times/sec., 10 times/sec. or 5 times/sec. | | | |
| Zero-adjust input (0-ADJ.) Auto-reference input (A-REF.) | Input condition: Non-voltage contact or NPN open-collector transistor input Signal condition: Negative logic, Input time duration 10 ms or more Signal level: ON ... 1.5 V or less (output current: 10 mA or less) OFF ... Supply voltage or open Guaranteed No. of zero-adjust input usage: 10 million times or less (for zero-adjust back-up setting) | | | | |
| Start / hold input | High level (supply voltage, or open): Start, Low level (1.5 V or less): Hold | | | | |
| Comparative outputs (OUT 1, OUT 2) | NPN open-collector transistor <ul style="list-style-type: none"> • Maximum sink current: 100 mA • Applied voltage: 35 V DC or less (between comparative output and GND) • Residual voltage: 1.3 V or less (at 100 mA sink current) 0.4 V or less (at 16 mA sink current) | | | | |
| | Response time | 5 ms or less (when start / hold input is used at a sampling rate of 200 times/sec.) | | | |
| | Hysteresis | Variable from 1 to 3,999 digits | | | |
| Display | 4 digit 7-segment red LED display (letter height: 8 mm 0.315 in) | | | | |
| | Display refresh rate | Selectable from 20 times/sec., 10 times/sec., 5 times/sec., 2.5 times/sec., 1 time/sec. or 0.5 time/sec. | | | |
| | Display range | Selectable span of 4,000 Nos. between -9999 to +9999 is displayed. ("+" is not displayed) | | | |
| | Display accuracy | $\pm(0.1\% \text{ F.S.} + 1 \text{ digit})$ at $23 \pm 5^\circ\text{C}$ 73.4 \pm 41 $^\circ\text{F}$, 35 to 85 % RH | | | |
| Temperature characteristics | $\pm 0.5\% \text{ F.S.}$ over 0 to $+50^\circ\text{C}$ +32 to +122 $^\circ\text{F}$ | | | | |
| Setting resolution | 1 digit | | | | |
| Threshold value setting range | -9999 to +9999 | | | | |
| Indicators | Polarity indication | Red LED (lights up when the displayed value or the threshold value is negative) | | | |
| | OUT 1 operation | Orange LED (Measurement mode: Lights up when OUT 1 is ON. Blinks when display is changed to OUT 1 threshold value display. Setting mode: Blinks when OUT 1 threshold value and comparison conditions are set or when zero scale of scale setting function is set.) | | | |
| | OUT 2 operation | Orange LED (Measurement mode: Lights up when OUT 2 is ON. Blinks when display is changed to OUT 2 threshold value display. Setting mode: Blinks when OUT 2 threshold value and comparison conditions are set or when full scale of scale setting function is set.) | | | |
| | Auto-reference operation | Green LED (lights up when auto-reference function is used) | | | |
| Functions | Auto-reference function, zero-adjust function, scale setting function, threshold value setting function, hysteresis setting function, comparative output timer function, start / hold function, memory clear function, power supply ON-delay function etc. | | | | |
| Environmental resistance | Ambient temperature | 0 to $+55^\circ\text{C}$ +32 to +131 $^\circ\text{F}$ (No dew condensation), Storage: -20 to $+70^\circ\text{C}$ -4 to +158 $^\circ\text{F}$ | | | |
| | Ambient humidity | 35 to 85 % RH, Storage: 35 to 85 % RH | | | |
| | Voltage withstandability | 1,500 V AC for one min. between all supply terminals connected together and enclosure | | | |
| | Insulation resistance | 100 M Ω , or more, with 500 V DC megger between all supply terminals connected together and enclosure | | | |
| | Vibration resistance | 10 to 55 Hz frequency, 1.5 mm 0.059 in amplitude in X, Y and Z directions for two hours each | | | |
| Shock resistance | 294 m/s ² (30 G) acceleration in X, Y and Z directions for three times each | | | | |
| Back-up memory | Non-volatile memory (EEPROM), Guaranteed write operations: 1,000,000 or less | | | | |
| Material | Enclosure: Polycarbonate | | | | |
| Connecting method | Terminal block connection | | | | |
| Weight | Net weight: 55 g approx. | | | | |

Notes: 1) Where measurement conditions have not been specified precisely, the conditions used were an ambient temperature of $+20^\circ\text{C}$ **+68 $^\circ\text{F}$** .

2) If this product is to be used as a CE (European standard EMC Directive) approved product, make sure to connect ferrite clamps, with one loop, on all the connection cables, as shown in the right figure. Also, make sure not to exceed 10 m **32.808 ft** in cable length.

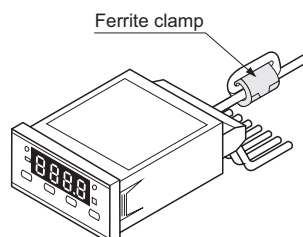

<Recommended ferrite clamp>

Noise filter for single line

ZCAT3035-1330

[Manufactured by TDK Corporation]

I/O CIRCUIT AND WIRING DIAGRAMS

Input circuit diagram

IN, ST / HOLD, 0-ADJ. / A-REF.

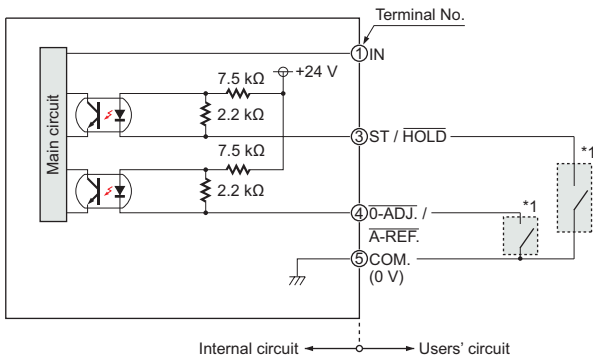

Terminal arrangement

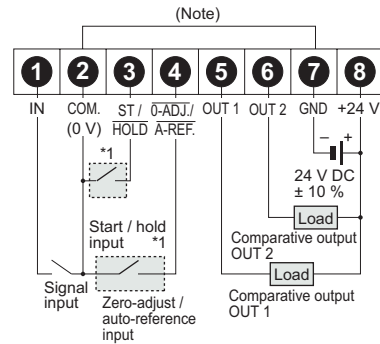

Note: COM. (0 V) is internally connected to GND.

Output circuit diagram

OUT1, OUT2

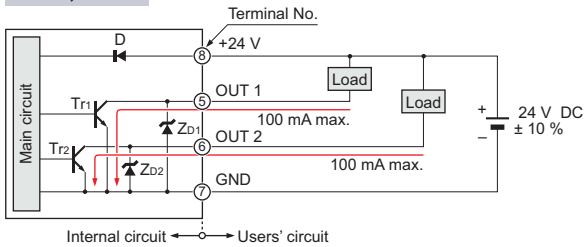

Symbols ... D: Reverse supply polarity protection diode
ZD1, ZD2: Surge absorption zener diode
Tr1, Tr2: NPN output transistor

* 1

Non-voltage contact or NPN open-collector transistor

ON: 1.5 V or less (output current 10 mA or less)
OFF: Supply voltage, or open

DIMENSIONS (Unit: mm in)

The CAD data in the dimensions can be downloaded from our website.

CA2-□

Digital panel controller

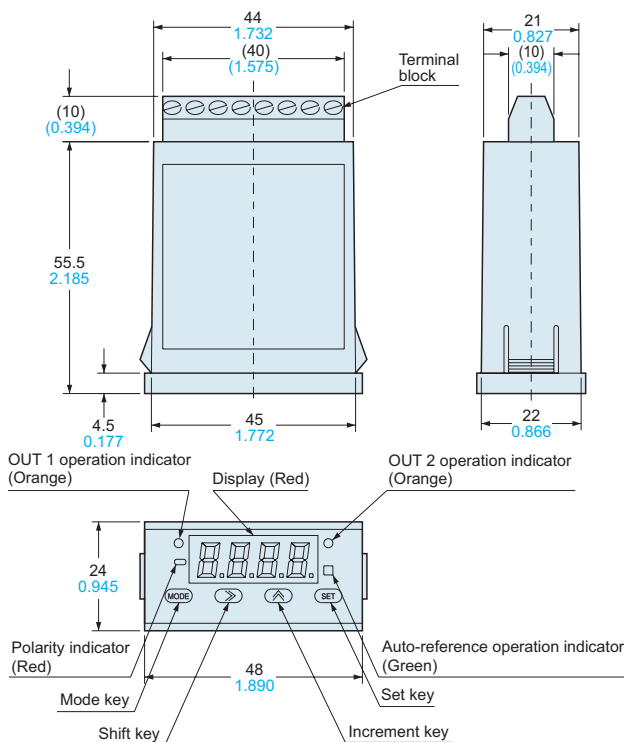

Panel cut-out dimensions

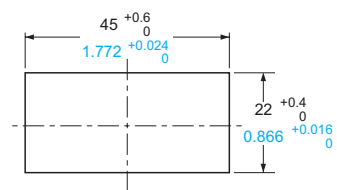

Note: The panel thickness should be 0.5 to 4 mm
0.020 to 0.157 in.

FIBER SENSORS

LASER SENSORS

PHOTO-ELECTRIC SENSORS

MICRO PHOTO-ELECTRIC SENSORS

AREA SENSORS

LIGHT CURTAINS

PRESSURE / FLOW SENSORS

INDUCTIVE PROXIMITY SENSORS

PARTICULAR USE SENSORS

SENSOR OPTIONS

SIMPLE WIRE-SAVING UNITS

WIRE-SAVING SYSTEMS

MEASURE-MENT SENSORS

STATIC CONTROL DEVICES

ENDOSCOPE

LASER MARKERS

PLC / TERMINALS

HUMAN MACHINE INTERFACES

ENERGY CONSUMPTION VISUALIZATION COMPONENTS

FA COMPONENTS

MACHINE VISION SYSTEMS

UV CURING SYSTEMS

Selection Guide

Laser Displacement

Magnetic Displacement

Collimated Beam

Digital Panel Controller

Metal-sheet Double-feed Detection

CA2