

(RoHS) RoHS-Compliant

Hollow Rotary Actuators **DG Series**

Frame Size 60 mm 130 mm 200 mm



DG Series

Hollow Rotary Actuators DG Series make the machine design, wiring and maintenance simple. 2 install base sizes, compact □ 60 mm, high-rigidity □ 130 mm and □ 200 mm, are available.

DG Series Common Features

Direct Drive
Simple but reliable design

Large-Diameter Hollow Output Table
Easy routing of wires and tubes

Accurate Positioning
Repetitive positioning accuracy: $\pm 0.004^\circ$
Lost motion: 0.033°
Angle transfer error: 0.067°

Shorter Positioning Time
Inertial loads can be positioned quickly using an α STEP motor.

High Torque, High Rigidity

Compact

High Permissible Torque

The hollow rotary actuators with larger permissible torque deliver stable, high-speed positioning of larger inertial loads.

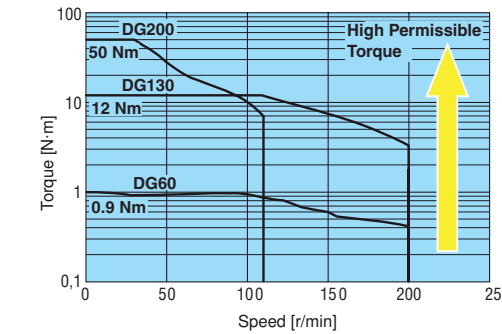

High Rigidity

The output table uses deep-groove ball bearings (two pieces) for the 60 mm frame-size type, and a cross-roller bearing for the 130 mm and 200 mm frame-size type. As the model number increases, the permissible moment load also increases but the displacement caused by the moment load decreases.

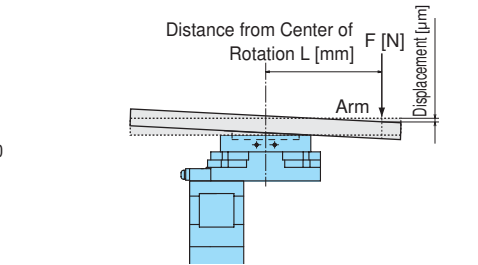

Displacement at distance L = 200 mm from center of rotation

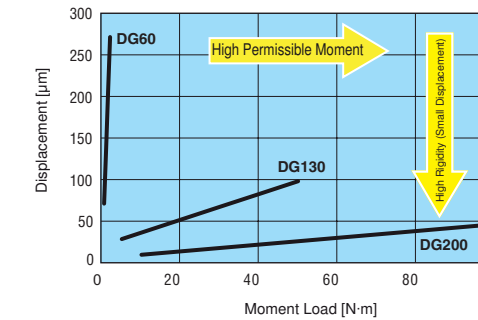

INDEX	
Features	2
Product Number Code	3
Product Lines	3
Structural Drawings	4
Safety Standards and CE Marking	5
System Configuration	5
Specifications	6
Dimensions	8
Accessories	11

Product Number Code

DG 130 R - AS A C

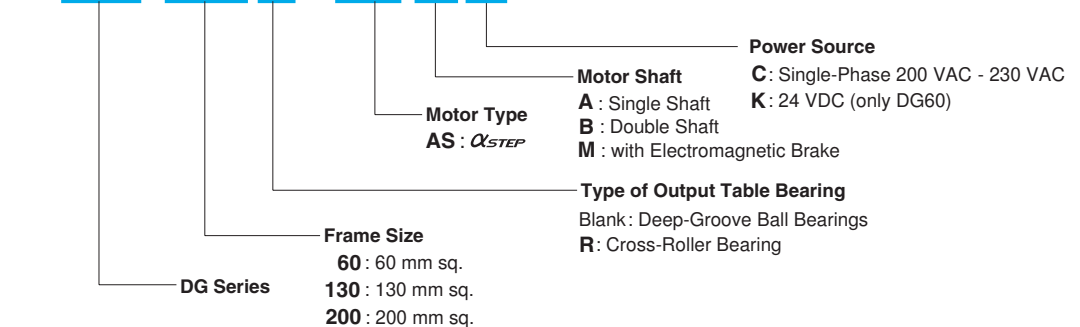

Product Lines

Power Supply	24 VDC	Single-Phase 200 - 230 VAC
Frame Size □ 60 mm	DG60-ASAK DG60-ASBK	
□ 130 mm	—	DG130R-ASAC DG130R-ASBC DG130R-ASMC
□ 200 mm	—	DG200R-ASAC DG200R-ASBC DG200R-ASMC

For the single-phase 100 - 115 VAC models and three-phase 200 - 230 VAC models, please contact the nearest Oriental Motor sales office.

Frame Size □ 60 mm

Frame Size □ 130 mm

Frame Size □ 200 mm



Permissible Torque	Bearing	Diameter of Hollow Section
0.9 N·m	Ball Bearing	Ø 28 mm (Rotational)
Safety Standard	24-VDC Input Driver	Actuator Weight
UL CE		0.5 kg



Permissible Torque	Bearing	Diameter of Hollow Section	High Permissible-Moment
12 N·m	Cross-Roller Bearing	Ø 62 mm (Not rotational)	
High Permissible-Thrust Load	Safety Standard	AC Input Driver	Actuator Weight
	UL CE		2.6 kg
Actuator Weight with Electromagnetic Brake			2.85 kg



Permissible Torque	Bearing	Diameter of Hollow Section	High Permissible-Moment
50 N·m	Cross-Roller Bearing	Ø 100 mm (Not rotational)	
High Permissible-Thrust Load	Safety Standard	AC Input Driver	Actuator Weight
	UL CE		9.5 kg
Actuator Weight with Electromagnetic Brake			9.9 kg

Hollow Rotary Actuators **DG Series**

● Direct Drive → Simple but Reliable Design

The output table of the hollow rotary actuator allows direct installation of the table or arm of your equipment. If your equipment performs indexing operation through use of a belt, pulley or other mechanical part, you can use the **DG Series** to reduce the number of parts and thereby reducing the need for maintenance.

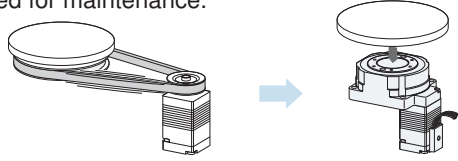

● Large-Diameter, Hollow Output Table → Simple Wiring and Piping

The diameter of the driven gear has been increased with the use of a single-stage reduction gear mechanism, resulting in a hollow shaft (through-hole) of sufficiently large diameter with respect to frame size. This helps reduce the complexity of wiring and piping, thus simplifying your equipment design.

	Frame size [mm]	Diameter of Hollow Section [mm]
DG60	60	Ø28
DG130R	130	Ø62
DG200R	200	Ø100

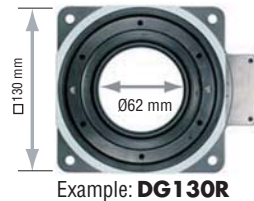

● Accurate Positioning

→ Repetitive Positioning Accuracy of ±0.004° & Lost Motion of 0.033°

The gear-reduction mechanism employs precision gears along with a proprietary adjustment mechanism that eliminates backlash. The repetitive accuracy of positioning from a single direction is ±0.004°, while lost motion in a positioning operation from two directions is 0.033°. These characteristics make the **DG Series** an ideal choice for applications in which accurate positioning is a must.

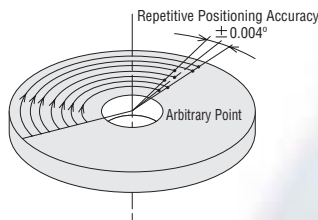

Structural Drawings

● DG60

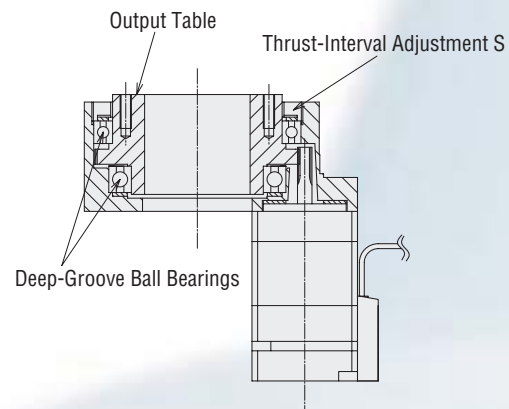

● DG130R, DG200R

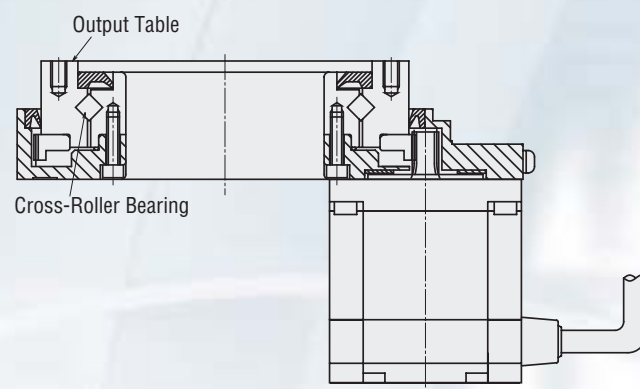

● Shorter Positioning Time → Quick Positioning of Inertial Loads

The drive motor of the **DG Series** is an α STEP stepping motor with built-in rotor-position detection sensor. This combination results in a shorter positioning time. Moreover, the actuator uses a dedicated driver to monitor the motor speed and position information, and switches to closed-mode control the moment it detects the risk of a misstep. Therefore, acceleration and deceleration times can be shortened for quicker positioning.

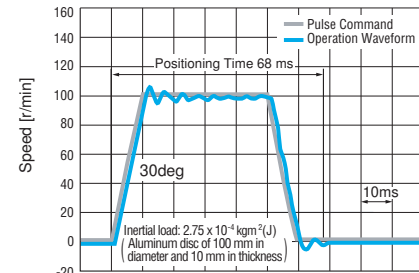

● Simple Homing → Less Design/Parts Procurement Time

The **DG Series** provides an optional home-sensor set that simplifies the return to home operation. The sensor set comes with all the parts required for the return to home operation, meaning you will spend less time designing, fabricating and procuring parts relating to sensor installation.

(Example of sensor/shielding plate installation on **DG130R**)

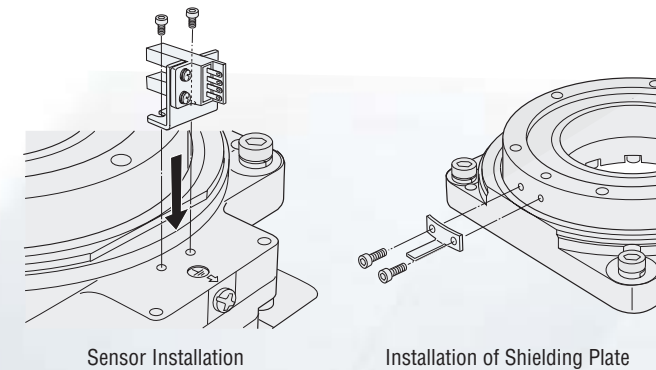

Safety Standards and CE Marking

Hollow rotary actuators **DG Series** employ an UL/CSA recognized α STEP motor. Motors and drivers are recognized for the following model name(s).

● DG60

	Model	Applicable Standards	Certification Body	File No.	CE Marking
Motor	ASM34AK-D ASM34BK-D	UL 60950 CSA C22.2 No.60950	UL	E208200	EMC Directive
Driver	ASD10A-K	UL 508C CSA C22.2 No.14 UL 1950 CSA C22.2 No.950	UL	E171462 E208200	

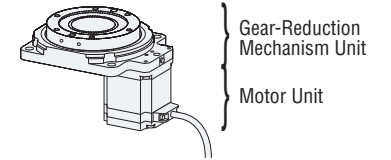

● DG130R and DG 200R

	Model	Applicable Standards	Certification Body	File No.	CE Marking
Motor	ASM66AC-D ASM66BC-D ASM66MC-D ASM911AC-D ASM911BC-D ASM911MC-D	UL 1004 UL 2111 CSA C22.2 No.100 CSA C22.2 No.77 EN60950-1 EN60034-1 EN60034-5 IEC60664-1	UL	E64199	Low Voltage Directive EMC Directive
Driver	ASD12A-C ASD20A-C	UL 508C CSA C22.2 No.14 EN60950-1 EN50178	UL	E171462	



The EMC value changes according to the wiring and layout. Therefore, the final EMC level must be checked with the actuator/driver incorporated in the user's equipment.

System Configuration

An example of a single-axis system configuration with the **SG8030JY** controller.

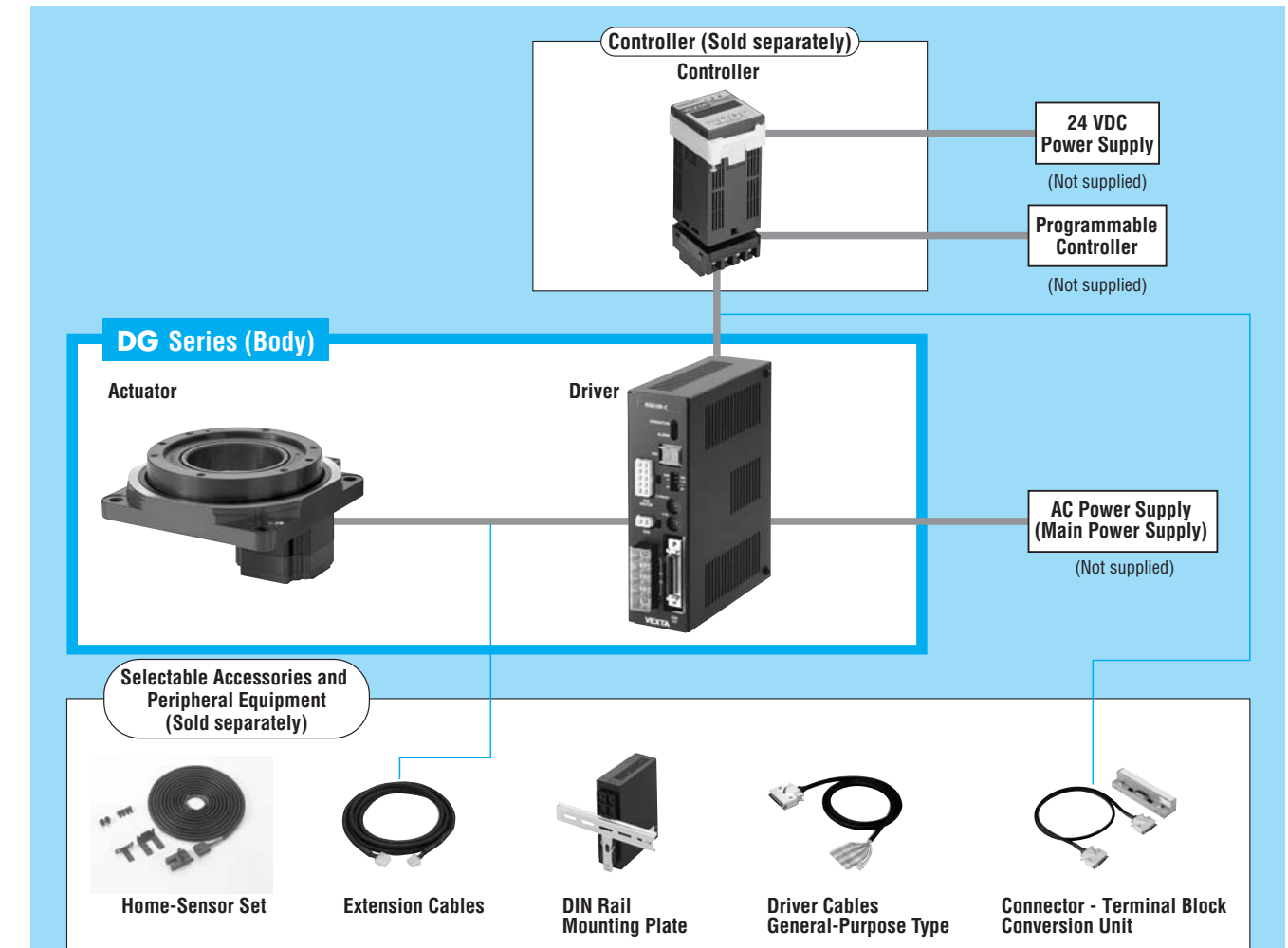

● Example of System Configuration (Body) (Sold separately)

DG Series	+	Controller	Extension Cable (3 m)	Home-Sensor Set	DIN Rail Mounting Plate	Connector - Terminal Block Conversion Unit (1 m)
DG130R-ASAC		SG8030JY-U	CC03AIP	PADG-SBY	PADPO1	CC36T1

● The system configuration shown above is an example. Other combinations are available.

Specifications

Specifications of Hollow Rotary Actuator Unit (RoHS)



Frame Size		60 mm	130 mm	200 mm
Model	24 VDC	DG60-ASAK		
	Single Shaft	DG60-ASBK		
	Double Shaft		DG130R-ASAC	DG200R-ASAC
	Single-Phase		DG130R-ASBC	DG200R-ASBC
	200-230 VAC		DG130R-ASMC	DG200R-ASMC
	Double Shaft			
Electromagnetic Brake				
Motor Type		αSTEP		
Type of Output Table Supporting Bearing		Deep-Groove Ball Bearing	Cross-Roller Bearing	
Permissible Torque *1		N·m	12	50
Inertial Moment *3		J: kg·m ²	4324 × 10 ⁻⁷	108160 × 10 ⁻⁶ 113344 × 10 ⁻⁶ *5
Permissible Speed		r/min	200	110
Gear Ratio			1:18	
Resolution *4			9000 P/R (Resolution Setting: 0.04°/step [500] [x1]) 18 000 P/R (Resolution Setting: 0.02°/step [1000] [x1]) 90 000 P/R (Resolution Setting: 0.004°/step [500] [x10]) 180 000 P/R (Resolution Setting: 0.002°/step [1000] [x10])	
Maximum Holding Torque *2		N·m	0	0
		Electromagnetic Brake	12	20
Repetitive Positioning Accuracy		sec	±15 (±0.004°)	
Lost Motion		min	2 (0.033°)	
Angular Transmission Error		min	4 (0.067°)	2 (0.033°)
Permissible Thrust Load		N	100	4000
Permissible Moment Load		N·m	2	100
Runout of Output Table Surface		mm	0.030	0.015
Runout of Output Table Inner (Outer) Diameter		mm	0.030	0.030
Parallelism of Output Table		mm	0.050	0.050
Degree of Protection			IP40 (IP20 for motor connector)	
Mass of Actuator Unit		kg	0.5	2.6 [2.85 *5] 9.5 [9.9 *5]

- *1 Permissible torque refers to the mechanical-strength limit of the gear-reduction mechanism. Be sure to keep the torque, including acceleration torque, within the permissible limit.
- *2 Maximum holding torque represents the holding torque of the output table when the motor is at a standstill.
- *3 Inertial moment is calculated through conversion at the output table of the motor rotor's inertial moment and the inertial moment in the reduction mechanism.
- *4 You can set one of four resolutions using the driver-resolution select switch or driver-resolution select signal. The factory driver settings are [1000] [x1] and 18000 P/R (0.02°/step).
- *5 with Electromagnetic Brake

Speed — Torque Characteristics

DG 60

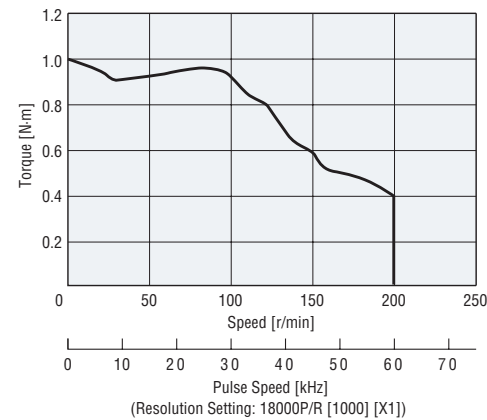

DG130R

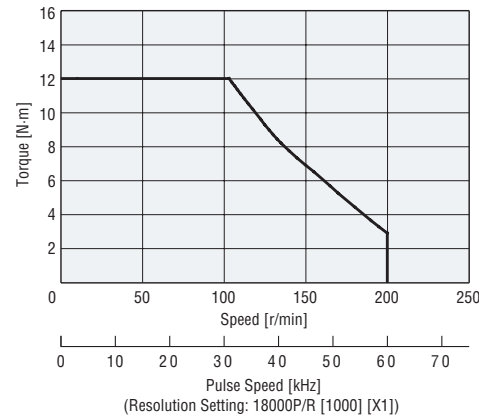

DG200R

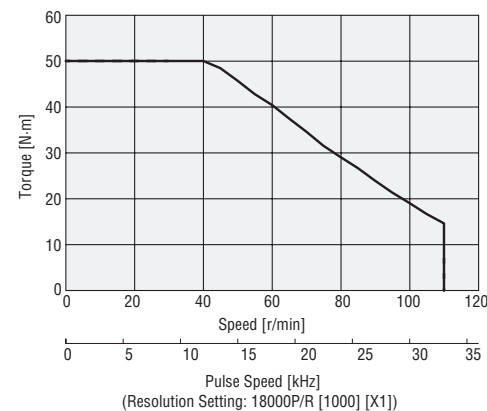

Load Inertia Positioning Time (Tact Time) Reference value

DG60

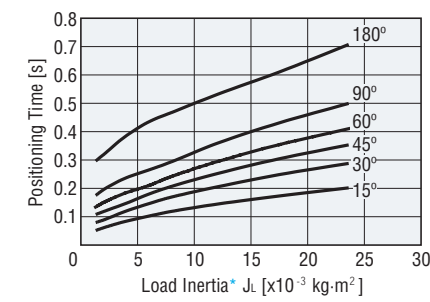

DG130R

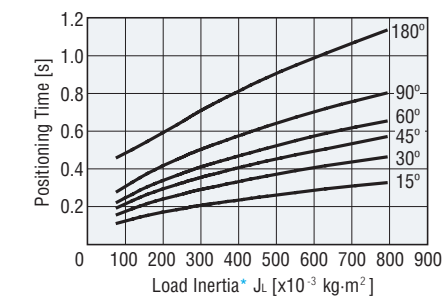

DG200R

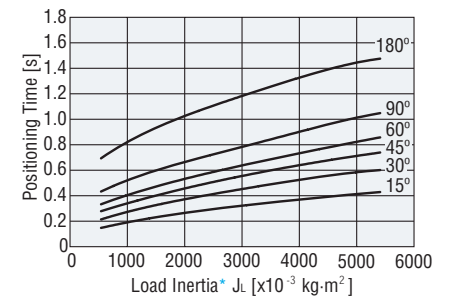

* The load inertia refers to the inertia of the customer's work.

Table Precision (at no load)

DG60

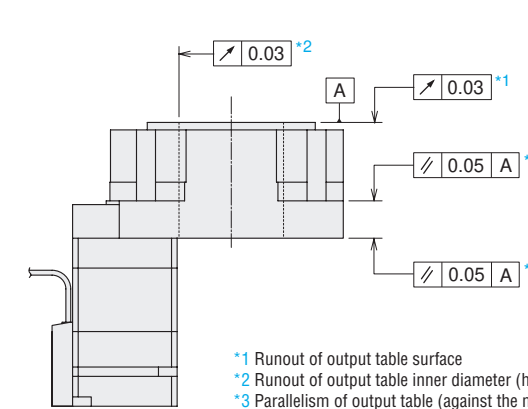

DG130, DG200

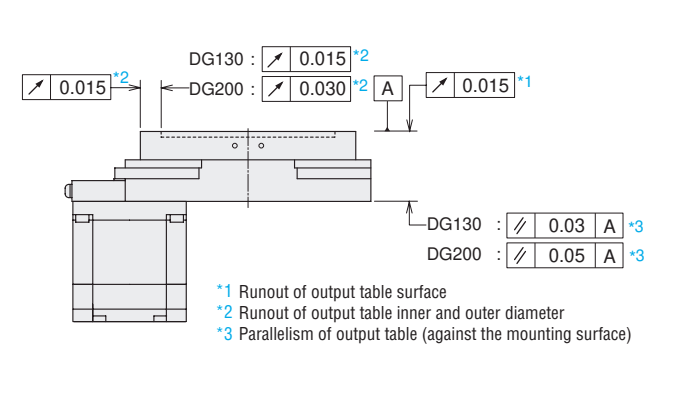

Displacement by Moment Load Reference value

The output table will be displaced when it receives the moment load. The graph plots the table displacement that occurs at distance L from the rotation center of the output table when a given moment load is applied in the negative direction. The displacement becomes approximately twofold when the moment load is applied in both the positive and negative directions.

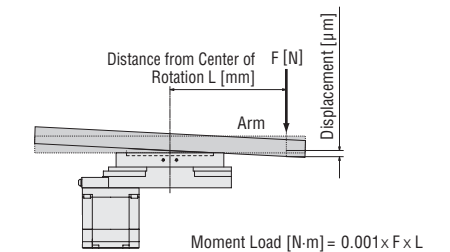

DG60

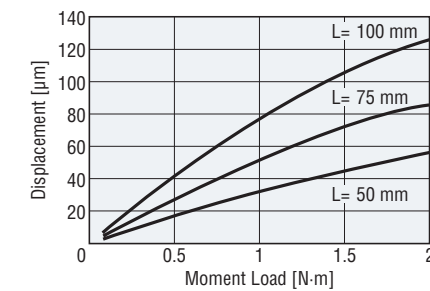

DG130R

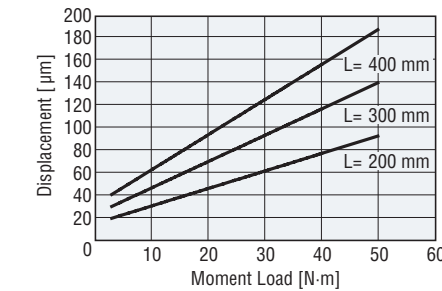

DG200R

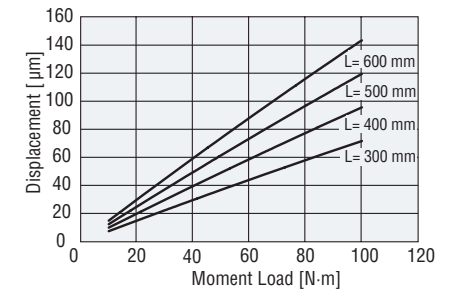

Dimensions (unit=mm)

Actuator Unit

Model	Actuator Model	Mass
DG60-ASAK	DGM60-ASAK	0.5 kg
DG60-ASBK	DGM60-ASBK	

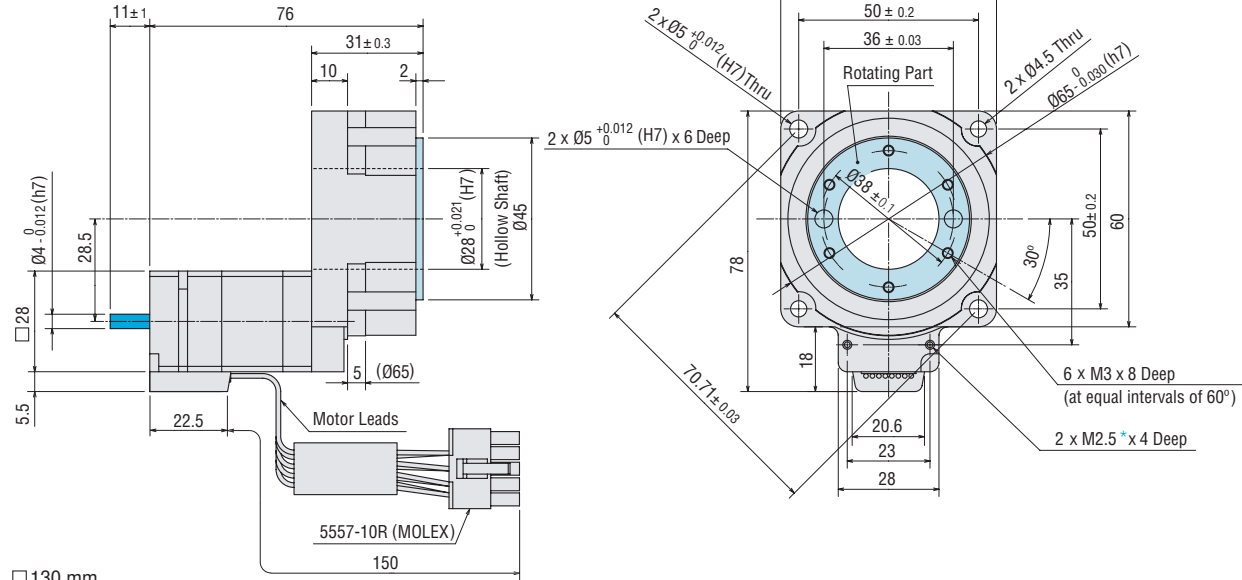

Model	Actuator Model	Mass
DG130R-ASAC	DGM130R-ASAC	2.6 kg
DG130R-ASBC	DGM130R-ASBC	

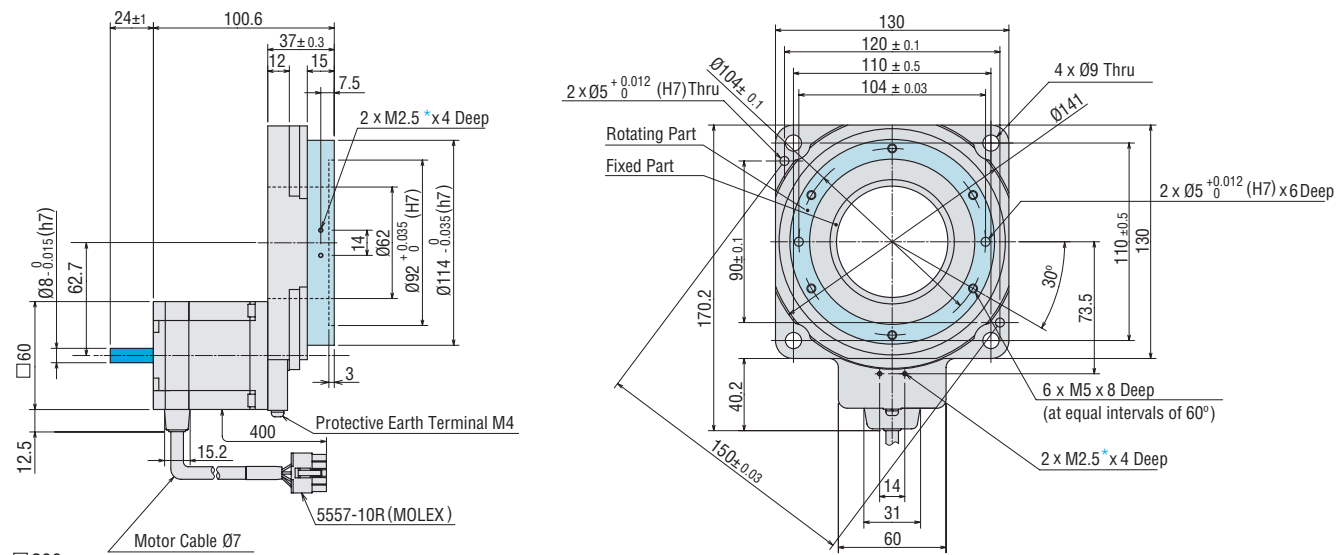

Model	Actuator Model	Mass
DG200R-ASAC	DGM200R-ASAC	9.5 kg
DG200R-ASBC	DGM200R-ASBC	

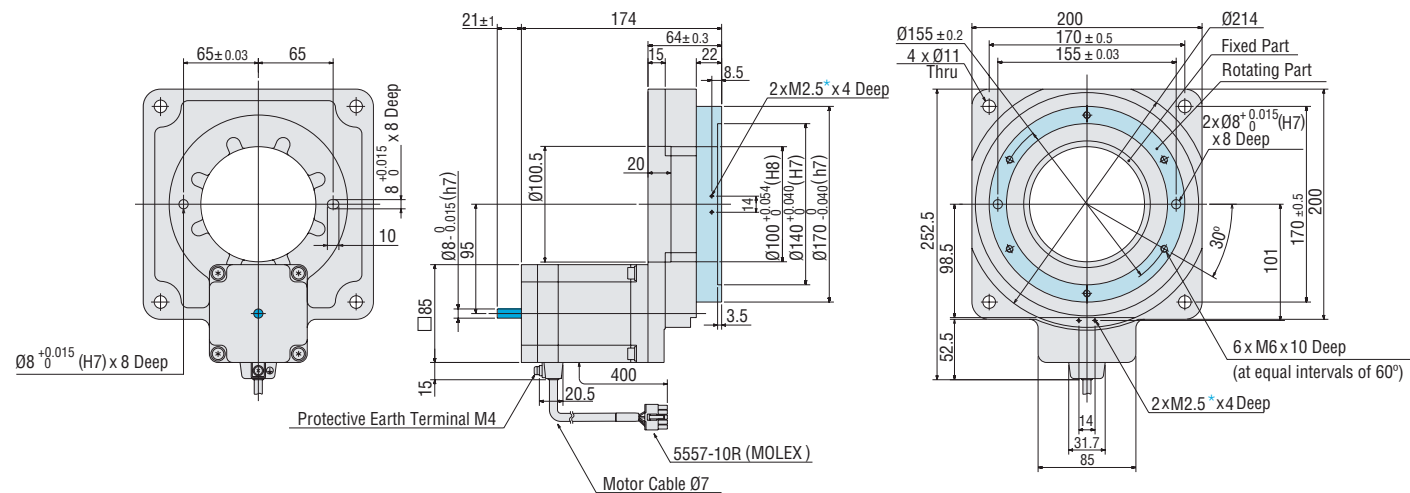

Actuator Unit with Electromagnetic Brake

Model	Actuator Model	Mass
DG130R-ASMC	DGM130R-ASMC	2.85 kg

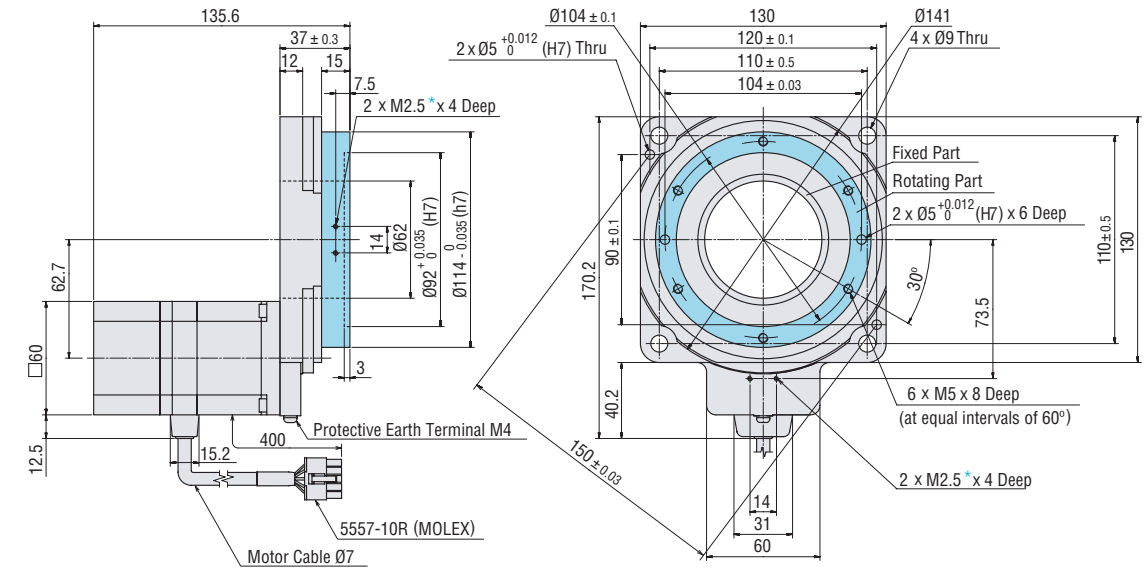

Model	Actuator Model	Mass
DG200R-ASMC	DGM200R-ASMC	9.9 kg

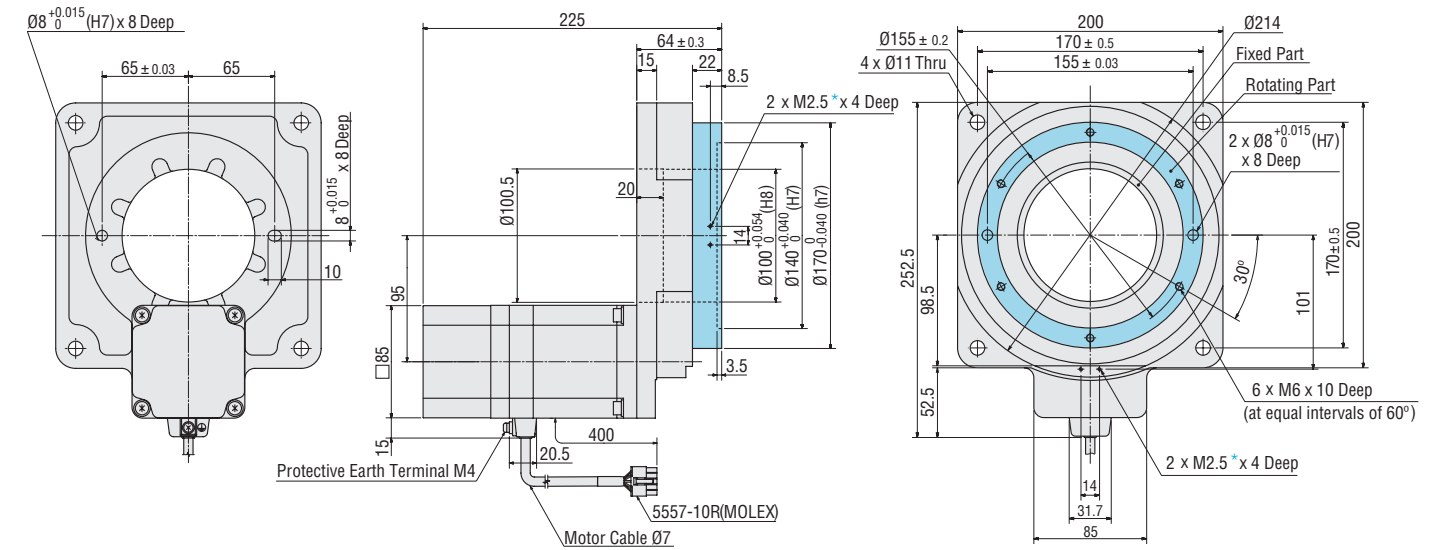

* Use M2.5 screw holes when installing the home-sensor set (sold separately). Do not use these holes for any purpose other than to install the home sensor.

Driver Unit

Driver Model: ASD10A-K
Mass: 0.25 kg

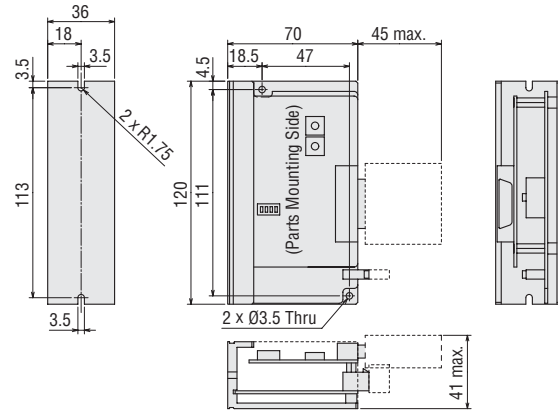

- I/O Connector (Included)
Cover assembly: 54331-1361 (MOLEX)
Connector: 54306-3619 (MOLEX)
- Power Supply Connector (Included)
Connector: 5557-02R (MOLEX)
Connector crimp terminal: 5556TL (MOLEX)

Driver Model: ASD12A-C, ASD20A-C
Mass: 0.8 kg

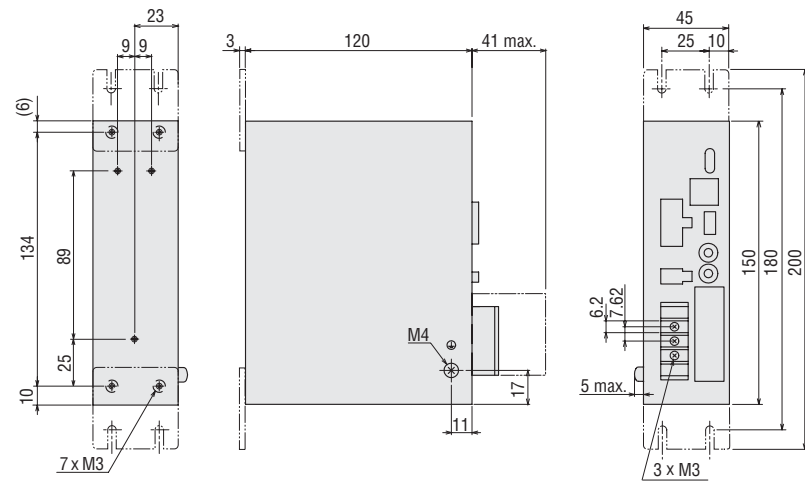

- Mounting Bracket (2 pieces, included)
Cover assembly: 54331-1361 (MOLEX)
Connector: 54306-3619 (MOLEX)

I/O Connector (Included)
Cover assembly: 54331-1361 (MOLEX)
Connector: 54306-3619 (MOLEX)

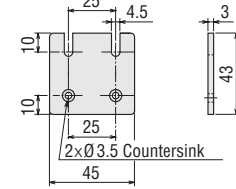

Accessories (Sold Separately)

Home-Sensor Set (RoHS)

A home-sensor set, which consists of a photo micro sensor, connector with robot cable, sensor mounting bracket, shielding plate and mounting screws, is provided to facilitate easy return to home operation.

All parts needed for return to home operation are included in the set, so you will spend less time designing, fabricating or procuring parts in connection with sensor installation. Installation is very easy, so you can start using the sensor right away.

Model	Applicable Products
PADG-SAY	DG60
PADG-SBY	DG130, DG200

Sensor Specifications

Model	EE-SX672R, EE-SX673R (OMRON)
Power Supply	5 ~ 24 VDC ± 10%, ripple (P-P) 10% or less
Current Consumption	30 mA or less
Control Output	PNP open-collector output, 5 ~ 24 VDC 50 mA or less Residual voltage 1.3 V or less (at load current of 50 mA)
Indicator Lamp	Detection display (red)
Sensor Logic	Normal open/Normal close (switchable, depending on connection)

Extension Cable (RoHS)

These extension cables are convenient when using the actuator and the driver more than 0.4 m (0.15 m for **DG60**) apart from each other



Flexible Extension Cables

Model	Length (L)
CC01AIP	1 m
CC02AIP	2 m
CC03AIP	3 m
CC05AIP	5 m
CC07AIP	7 m
CC10AIP	10 m
CC15AIP	15 m
CC20AIP	20 m

Flexible Extension Cables for Electromagnetic Brake Motor

Model	Length (L)
CC01AIPM	1 m
CC02AIPM	2 m
CC03AIPM	3 m
CC05AIPM	5 m
CC07AIPM	7 m
CC10AIPM	10 m
CC15AIPM	15 m
CC20AIPM	20 m

* The maximum extension length of **DG60** is 10.15 m.

Dimensions (Unit: mm)

For Standard Motor

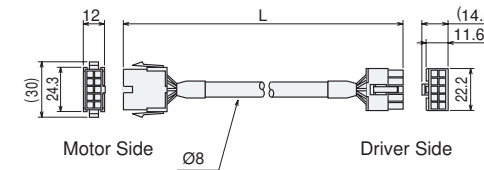

For Electromagnetic Brake Motor

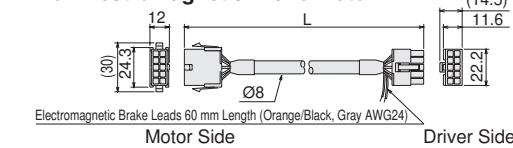

Driver Cable (RoHS)

This is a shielded cable equipped with, at one end of the cable, the half-pitch connector that snaps into the driver for **DG** series.

Model	Length (L)
CC36D1-1	1m
CC36D2-1	2m

Control I/O Pin: 36 pins



Installing the Home-Sensor Set

Be aware of the following points when installing the optional home-sensor set:

- Set the operating conditions so that the operating temperature stays at 40°C or below and the surface temperature of the hollow rotary actuator motor stays at 90°C or below.
- When performing home hunting using the counter-output shaft of the motor, the user must provide a separate sensor, mounting bracket and other necessary parts.

Flexible Cable (RoHS)

We recommend these flexible cables when the actuator is installed on a moving section and the cable is repeatedly bent and flexed.



Flexible Extension Cables

Model	Length (L)
CC01SAR	1 m
CC02SAR	2 m
CC03SAR	3 m
CC05SAR	5 m
CC07SAR	7 m
CC10SAR	10 m

Flexible Extension Cables for Electromagnetic Brake Motor

Model	Length (L)
CC01SARM2	1 m
CC02SARM2	2 m
CC03SARM2	3 m
CC05SARM2	5 m
CC07SARM2	7 m
CC10SARM2	10 m

Dimensions (Unit: mm)

For Standard Motor

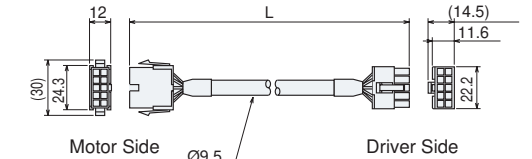

For Electromagnetic Brake Motor

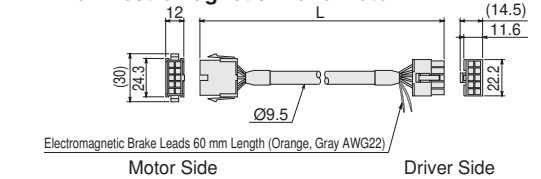

Dimensions (Unit: mm)

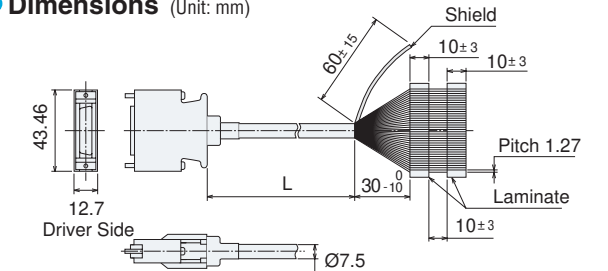

Accessories (Sold Separately)

■ DIN Rail mounting Plate: PADP01 **RoHS**

This mounting plate is convenient for installing the driver for **DG130R and DG200R** on DIN rails with ease. The required installation screws come with this installation plate.

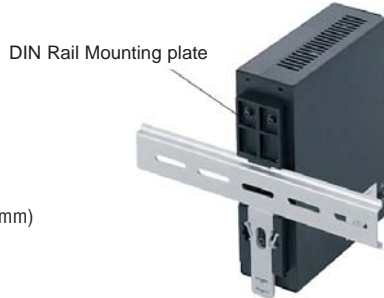

● Dimensions (Unit: mm)

Mass: 20 g

• Screws:

M3 P0.5, 8 mm long, 3 pieces included

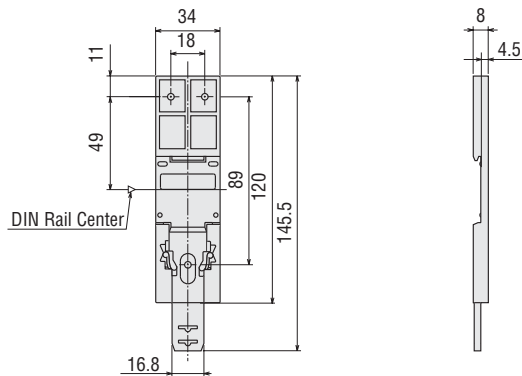

Motorized Linear Slides

EZS Series



- ➔ High transportable mass
- ➔ Space-Saving
- ➔ High thrust force
- ➔ High-Speed positioning
- ➔ Long-Term Performance
- ➔ Maintenance-Free

Motorized Cylinders

EZC Series



This product is manufactured at a plant certified with the international standards **ISO 9001** (for quality assurance) and **ISO 14001** (for systems of environmental management).

Specifications are subject to change without notice.

This catalogue was published in March, 2009.

Orientalmotor

ORIENTAL MOTOR (EUROPA) GmbH

www.orientalmotor.de

European Headquarters and Düsseldorf Office

Schiesstraße 74
40549 Düsseldorf, Germany
Tel: 0211-5206700 Fax: 0211-52067099

Munich Office

Carl-von-Linde-Straße 42
85716 Unterschleißheim, Germany
Tel: 089-318122500 Fax: 089-318122525

Hamburg Office

Meckelfelder Weg 2
21079 Hamburg, Germany
Tel: 040-76910443 Fax: 040-76910445

Jena Office

Wildenbruchstraße 15
07745 Jena, Germany
Tel: 03641-675280 Fax: 03641-675288

Stuttgart Office

Tel: 07335-924853 Fax: 07335-924854

ORIENTAL MOTOR (UK) LTD.

www.oriental-motor.co.uk

Unit 5, Faraday Office Park,
Rankine Road, Basingstoke,
Hampshire RG24 8AH U.K.
Tel: 01256-347090 Fax: 01256-347099

ORIENTAL MOTOR (FRANCE) SARL

www.orientalmotor.fr

France Headquarters

32, Avenue de l'île Saint Martin
92737 Nanterre Cedex, France
Tel: 01 47 86 97 50 Fax: 01 47 82 45 16

Lyon Office

10, Allée des Sorbiers
69673 Bron Cedex, France
Tel: 04 78 41 15 02 Fax: 04 78 41 15 90

ORIENTAL MOTOR ITALIA s.r.l.

www.orientalmotor.it

Italy Headquarters

Via A. De Gasperi, 85
20017 Mazzo di Rho (MI), Italy
Tel: 02-93906346 Fax: 02-93906348

Bologna Office

Via mori, 6
40054 Prunaro di Budrio (BO), Italy
Tel: 051-6931249 Fax: 051-6929266

Verona Office

Piazza Roma, 3A
37066 Sommacampagna (VR), Italy
Tel: 045-8961049 Fax: 045-8971978

ORIENTAL MOTOR CO., LTD.

www.orientalmotor.co.jp

Headquarters

16-17, Ueno 6-chome
Taito-ku, Tokyo 110-8536, Japan
Tel: (03)3835-0684 Fax: (03)3835-1890

For more information please contact: