

(RoHS) RoHS-Compliant

2-Phase Stepping Motor and Driver Package

RBK Series

Microstep Drive

2-phase stepping motor and DC input microstep driver in one package.
Includes Oriental Motor's proprietary Smooth Drive Function, to easily achieve low-vibration operation.



Adopting a Compact and High Performance Microstep Driver

2-Phase Stepping Motor and Driver Package RBK Series

2-phase stepping motor and DC input microstep driver in one package.

Includes Oriental Motor's proprietary Smooth Drive Function, to easily achieve low-vibration operation.



Smooth Drive Function

The Smooth Drive Function is a function that automatically controls the motor's microstep drive operation at the same travel and speed in the full-step mode, without the operator having to change the speed settings of the driver's pulse input. It enables the low-vibration operation available with the microstepping drive to be achieved with the flick of a switch.

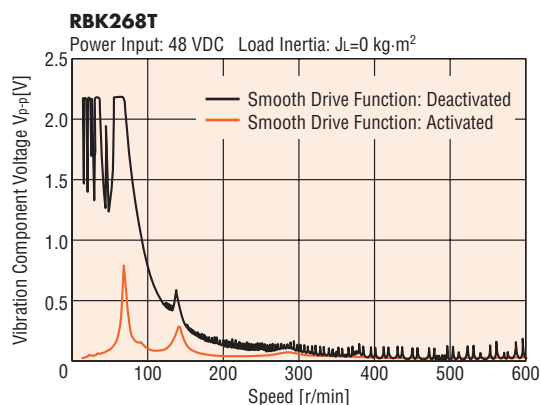

Microstep Function

The microstepping driver electronically divides the basic step angle of the motor ($1.8^\circ/\text{step}$) by up to 128 without the use of a reduction mechanism or other mechanical element. 16 different resolutions are available. The available range of setting is resolution 200 ($1.8^\circ/\text{step}$) to 25600 ($0.0140625^\circ/\text{step}$). The step angle can be easily set using the built-in switches to the driver. This function enables low-vibration and low-noise equipment.

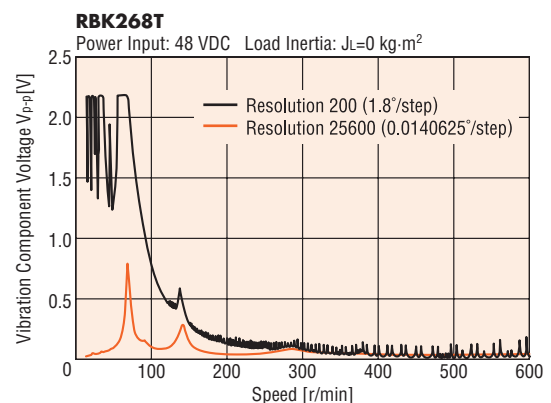

Third Harmonic Waveform Correction Function

This function corrects motor drive current waveforms. It provides improved angle accuracy and reduced vibrations.

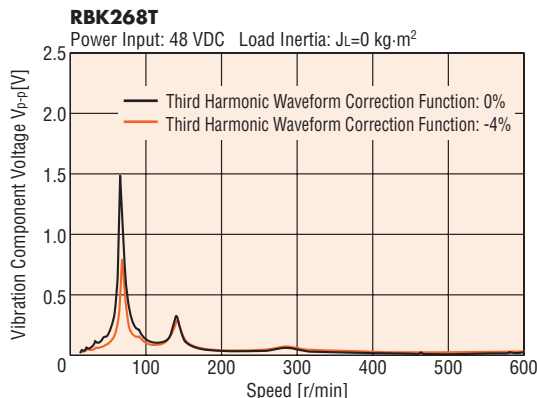

Vibration Suppression Function

This function improves vibrations at medium speed range of the stepping motor. It enables reduced risk of missteps due to vibrations.

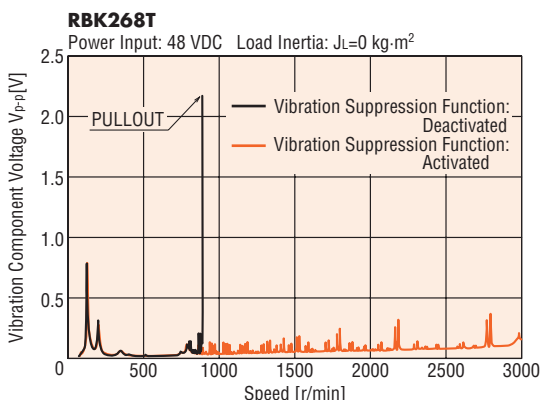

Adoption of Wide Voltage Range Driver

The **RBK** Series adopts a constant current driver with a wide voltage range of 20 to 75 VDC and 4.5 A/phase effective value (6.3 A/phase peak value). This enables it to support a wide range of power sources.

- **RBK26□T** equips a constant current driver with a voltage range of 20 to 75 VDC and 4.2 A/phase effective value (5.9 A/phase peak value).

Comparison of Speed – Torque Characteristics

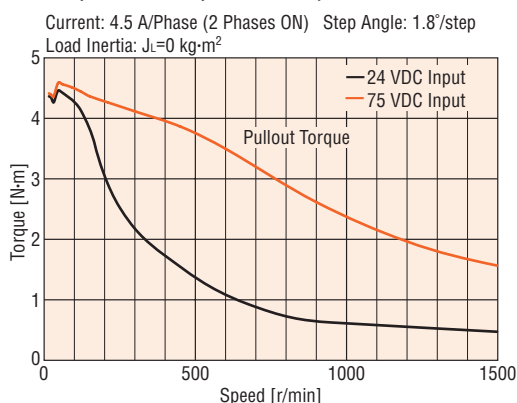

- Raising the power supply voltage enables increased torque at high-speed operation.

Conforming to Major Safety Standards

The **RBK** Series is UL-recognized and CSA-certified. It also bears the CE Mark as a proof of conformance to the Low Voltage Directives.

RoHS RoHS-Compliant

The **RBK** Series conforms to the RoHS Directive that prohibits the use of six chemical substances including lead and cadmium.

RoHS (Restriction of Hazardous Substances) Directive:

Directive on restriction of the use of certain hazardous substances in electrical and electronic equipment (2002/95/EC). The RoHS Directive prohibits the use of six chemical substances in electrical and electronic products sold in the EU member states. The six controlled substances are: lead, hexavalent chromium, cadmium, mercury and two specific brominated flame-retardants (PBB and PBDE).

The motor conforms to the IP65 standard of ingress protection against dust and water.

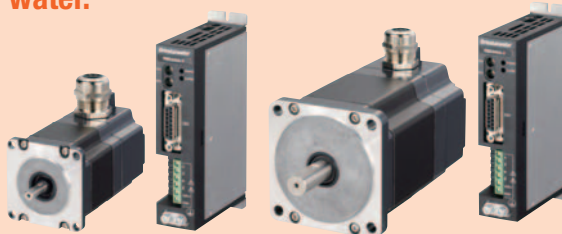

Terminal-Block Connection Design

The motor can be wired directly from its terminal block.

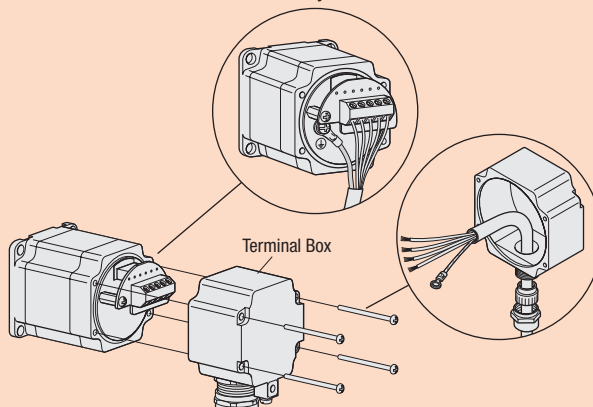

No Motor/Driver Relay

Since the motor cable can be connected directly with the driver terminals, there is no need for wire connection or soldering on a relay terminal block.

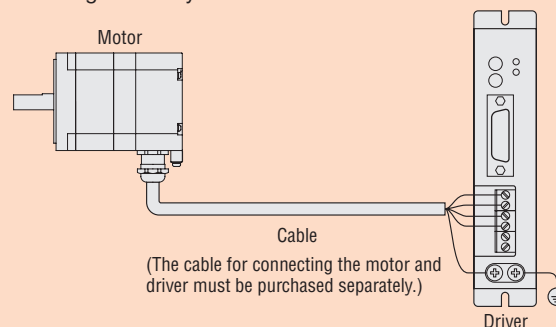

System Configuration

An example of system configuration with the **SG8030JY** controller.

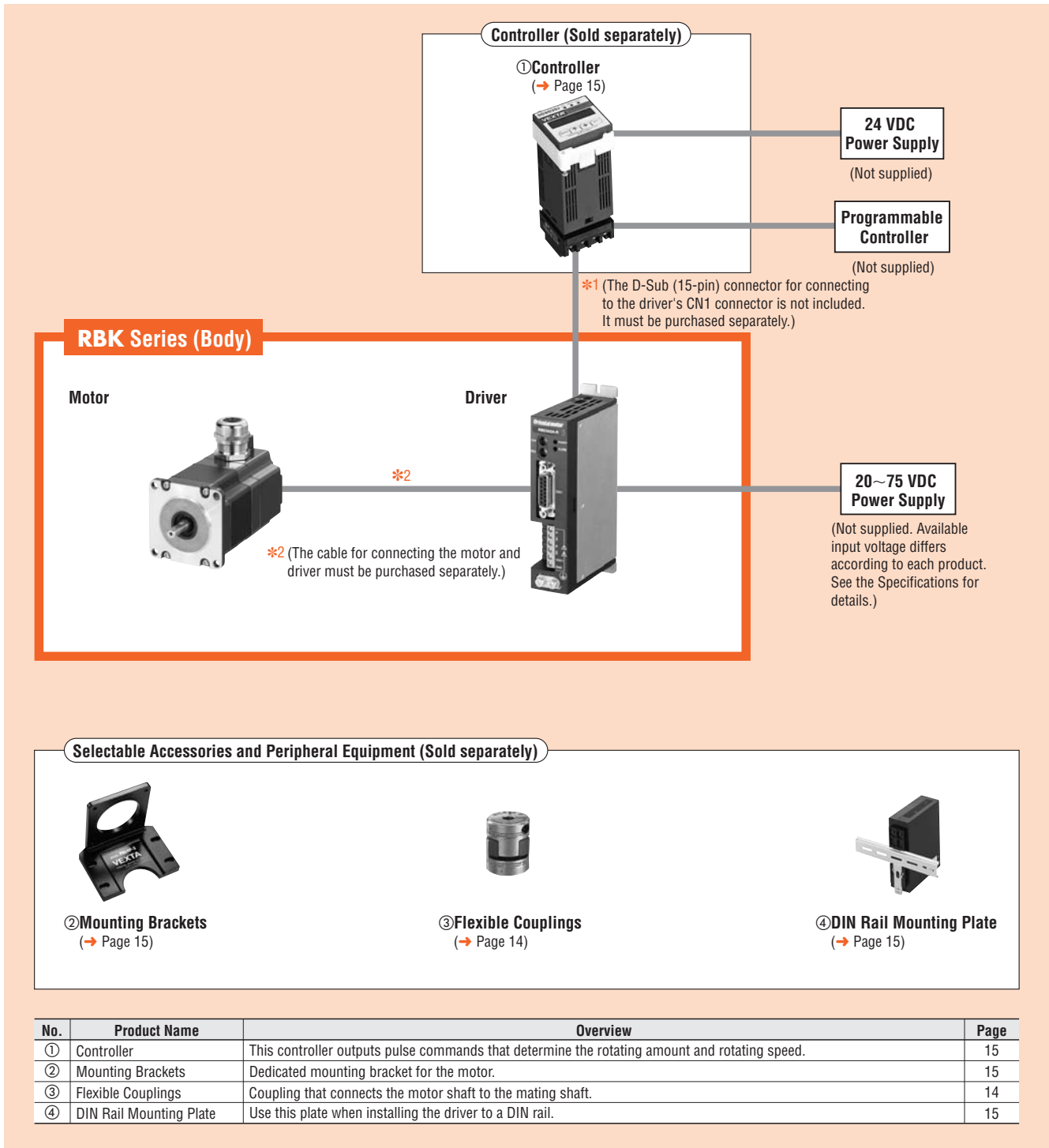

● Example of System Configuration

(Body)

(Sold separately)

RBK Series	+	Controller	Mounting Bracket	Flexible Coupling
RBK266T		SG8030JY-U	PAL2P-2	MCS2005F04

● The system configuration shown above is an example. Other combinations are available.

Safety Standards and CE Marking

Model	Standards	Certification Body	Standards File No.	CE Marking
Motor	UL 1004, UL 2111 CSA C22.2 No.77 CSA C22.2 No.100	UL	E64199	Low Voltage Directives EMC Directives
	EN 60034-1 EN 60034-5 EN 60950 IEC 60664-1	—	—	
Driver	UL 508C* CSA C22.2 No.14	UL	E171462	Low Voltage Directives EMC Directives
	EN 50178	—	—	

* Maximum Surrounding Air Temperature for UL: 40°C (UL 508C)

- When the system is approved under various safety standards, the model names in the motor and driver names are the approved model names.
- The package is declared voluntary compliance with the EMC Directive. The EMC Directive value changes according to the wiring and layout. Therefore, the final EMC level must be checked with the motor/driver incorporated in the user's equipment.

Product Number Code

RBK 2 6 6 T

① ② ③ ④ ⑤

①	Series	RBK: RBK Series
②	2: 2-Phase	
③	Motor Frame Size	6: 56.4 mm 9: 85 mm
④	Motor Case Length	
⑤	Motor Classification	

Product Line

Frame Size	Model (Single Shaft)
56.4 mm	RBK264T
	RBK266T
	RBK268T
85 mm	RBK296T
	RBK299T
	RBK2913T

The following items are included in each product.

Motor, Driver, Operating Manual

- The cable for connecting the motor and driver, and the D-Sub (15-pin) connector for connecting to the driver's CN1 connector are not included. They must be purchased separately.

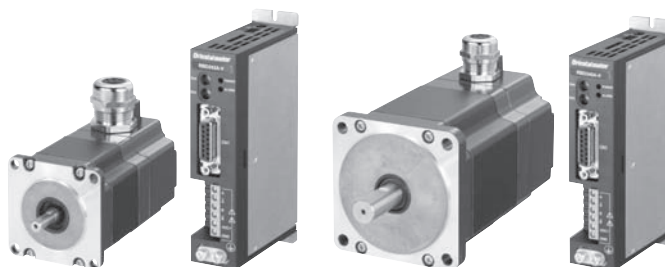

Motor Frame Size 56.4 mm

Specifications RoHS



Model	Single Shaft	RBK264T	RBK266T	RBK268T	
Maximum Holding Torque*1	N·m	0.48	1.17	1.75	
Rotor Inertia	J: kg·m ²	120×10 ⁻⁷	300×10 ⁻⁷	480×10 ⁻⁷	
Rated Current	A/Phase	4.2			
Basic Step Angle		1.8°			
Power Source		20~75 VDC 4.9 A			
Excitation Mode		Microstep			
Degree of Protection		Motor: IP65*2 Driver: IP20			
Mass	Motor	kg	0.6	0.9	1.2
	Driver	kg	0.35		
Dimension No.	Motor		[1]		
	Driver		[3]		

- *1 The holding torque (2-phase: 2-phase excitation) is the maximum holding power (torque) the motor has when power is being supplied but the motor shaft is not rotating (rated current). The driver's automatic current cutback function at motor standstill reduces maximum holding torque by approximately 50%.
- *2 Excluding the gap between the shaft and the flange.

Speed – Torque Characteristic fs: Maximum Starting Frequency

● 24 VDC Input

RBK264T

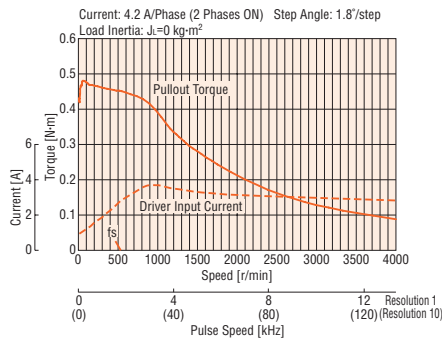

RBK266T

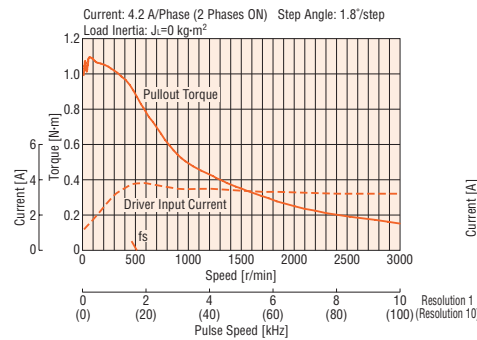

RBK268T

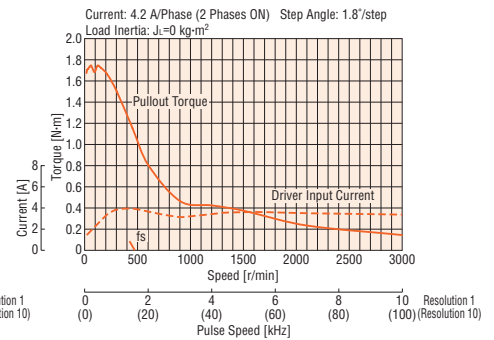

● 48 VDC Input

RBK264T

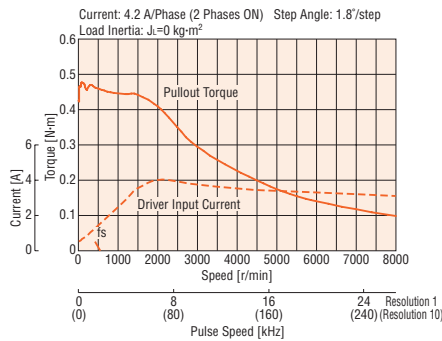

RBK266T

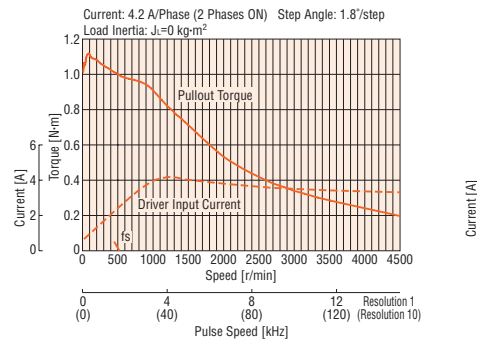

RBK268T

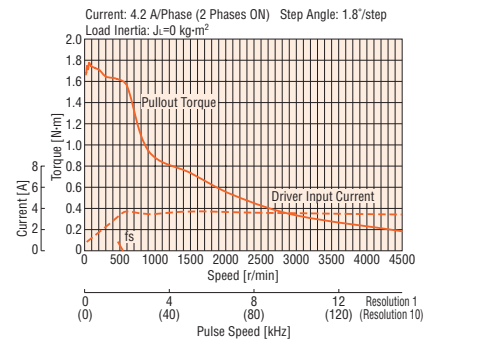

● 75 VDC Input

RBK264T

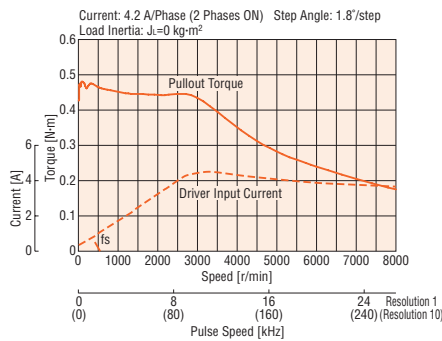

RBK266T

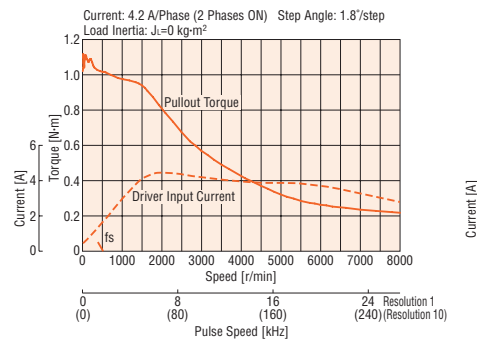

RBK268T

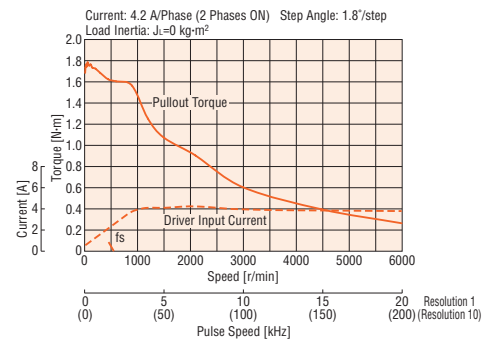

● The pulse input circuit responds to 250 kHz with a pulse duty of 50%.

Notes:

- Pay attention to heat dissipation from motor as there will be a considerable amount of heat under certain conditions. Be sure to keep the temperature of the motor case under 100°C. (Under 75°C is required to comply with UL or CSA Standards as the motor is recognized as insulation class A.)
- The driver's automatic current cutback function at motor standstill reduces maximum holding torque by approximately 50%.

Motor Frame Size 85 mm

Specifications RoHS



Model		Single Shaft	RBK296T	RBK299T	RBK2913T
Maximum Holding Torque ^{*1}		N·m	2.2	4.4	6.6
Rotor Inertia		J: kg·m ²	1400×10 ⁻⁷	2700×10 ⁻⁷	4000×10 ⁻⁷
Rated Current		A/Phase		4.5	
Basic Step Angle				1.8°	
Power Source			20~75 VDC 5.2 A		
Excitation Mode			Microstep		
Degree of Protection			Motor: IP65 ^{*2} Driver: IP20		
Mass	Motor	kg	2.1	3.2	4.3
	Driver	kg		0.35	
Dimension No.	Motor			[2]	
	Driver			[3]	

- *1 The holding torque (2-phase: 2-phase excitation) is the maximum holding power (torque) the motor has when power is being supplied but the motor shaft is not rotating (rated current). The driver's automatic current cutback function at motor standstill reduces maximum holding torque by approximately 50%.
- *2 Excluding the gap between the shaft and the flange.

Speed – Torque Characteristic fs: Maximum Starting Frequency

24 VDC Input

RBK296T

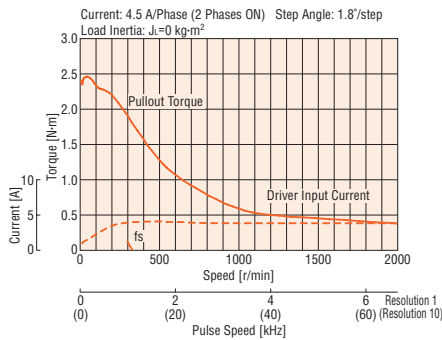

RBK299T

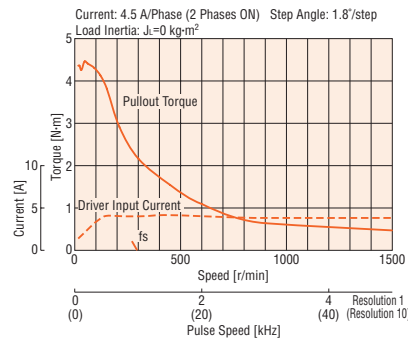

RBK2913T

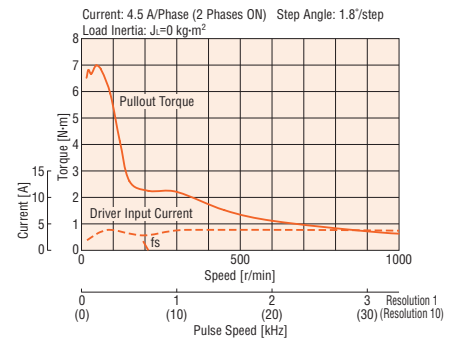

48 VDC Input

RBK296T

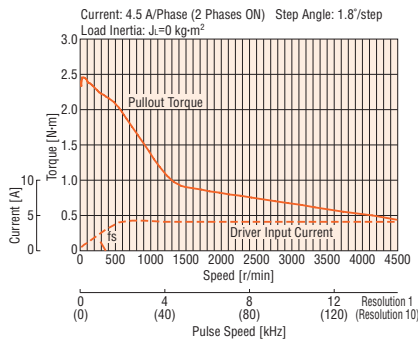

RBK299T

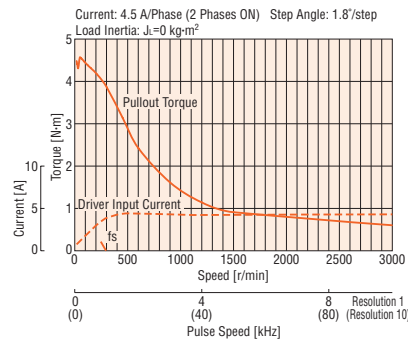

RBK2913T

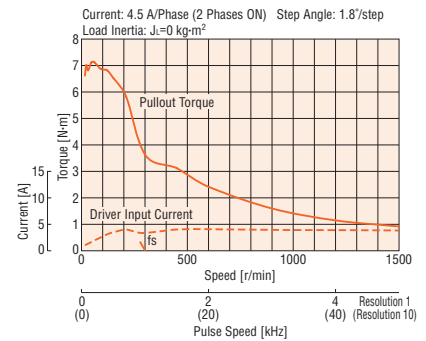

75 VDC Input

RBK296T

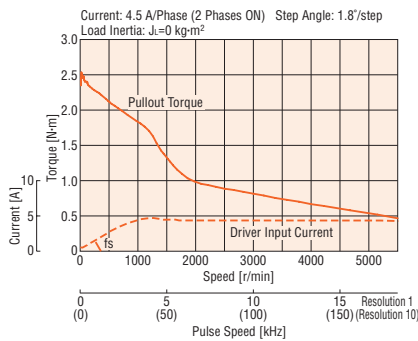

RBK299T

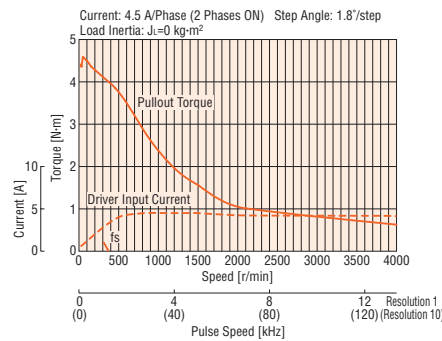

RBK2913T

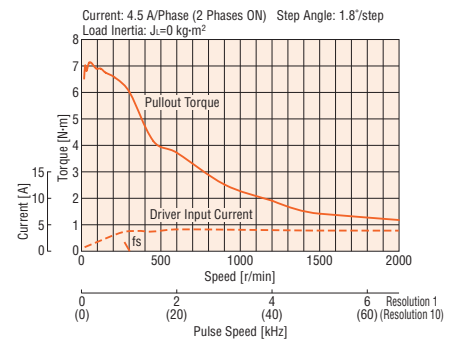

● The pulse input circuit responds to 250 kHz with a pulse duty of 50%.

Notes:

- Pay attention to heat dissipation from motor as there will be a considerable amount of heat under certain conditions. Be sure to keep the temperature of the motor case under 100°C. (Under 75°C is required to comply with UL or CSA Standards as the motor is recognized as insulation class A.)
- The driver's automatic current cutback function at motor standstill reduces maximum holding torque by approximately 50%.

Driver Specifications

Input Signals	Input Mode	Photocoupler Input PLS signal, DIR signal: Input resistance 200 Ω Input current 5~20 mA Photocoupler "ON": 3~5.25 V Photocoupler "OFF": 0~1 V (Line driver input: -5.25~1 V) (Voltage between terminals) PLS24 signal, DIR24 signal: Input resistance 2.7 kΩ Input current 5~20 mA Photocoupler "ON": 21.6~26.4 V Photocoupler "OFF": 0~1 V (Voltage between terminals) All windings off signal, Step angle select signal: Input resistance 3 kΩ Input current 20 mA or less Photocoupler "ON": 4.5~26.4 V Photocoupler "OFF": 0~1 V (Voltage between terminals)
	Pulse Signal	Operation command pulse signal Negative logic pulse input Pulse width: 2 μs minimum (Line driver input: 1 μs minimum), Pulse rise/fall: 1 μs maximum Pulse duty 50% and below The motor moves one step when the pulse input is switched from photocoupler ON to OFF. Maximum input pulse frequency 250 kHz (Line driver input: 500 kHz) (When the pulse duty is 50%)
	Rotation Direction Signal	Rotation direction signal, Photocoupler "ON": CW, Photocoupler "OFF": CCW Negative logic pulse input
	All Windings Off Signal	When in the "photocoupler ON" state, the output current to the motor is cut off and the motor shaft can be rotated manually. When in the "photocoupler OFF" state, the output current to the motor is turned on.
	Step Angle Select Signal	When in the "photocoupler ON" state, the motor operates with the basic step angle, regardless of the setting of the step angle setting switch. When in the "photocoupler OFF" state, the motor operates with the step angle set with the step angle setting switch.
Output Signals	Output Mode	Photocoupler, Open-collector output External use condition: 30 VDC maximum, 10 mA maximum
	Current Cutback Signal	When the automatic current cutback function is activated, the output turns on. (Photocoupler "ON")
	Alarm Signal	When one of the driver's protective functions is activated, the output turns off. (Photocoupler "OFF")
	Excitation Timing Signal	The signal is output every time the excitation sequence returns to the initial stage "0." (Photocoupler "ON") Example) 1.8°/step (1 resolution): Signal output every 4 pulses 0.45°/step (4 resolutions): Signal output every 16 pulses
Functions	Third Harmonic Waveform Correction, Smooth Drive, Vibration Suppression, Automatic Current Cutback, Step Angle Select, All Windings Off, Excitation Timing	
Cooling Method	Natural ventilation	

General Specifications

Specifications		Motor	Driver
Insulation Class		Class B (130°C) [Recognized as class A (105°C) by UL/CSA Standard]	-
Insulation Resistance		100 MΩ or more when 500 VDC megger is applied between the motor windings and the case under normal ambient temperature and humidity.	-
Dielectric Strength		Sufficient to withstand 1.5 kV at 50 Hz or 60 Hz applied between the motor windings and the case for 1 minute under normal ambient temperature and humidity.	-
Operating Environment (In Operation)	Ambient Temperature	-10~+50°C (non-freezing)	0~+40°C (non-freezing)
	Ambient Humidity	85% or less (non-condensing)	
	Atmosphere	Not exposed to corrosive gases	No corrosive gases, dust, water or oil.
Temperature Rise		Temperature rise of the windings is 80°C or less measured by the change resistance method. (at rated current, at standstill, two phases energized) RBK26□T : when equipped with an aluminum heat sink of 250×250 mm, 10 mm thick To comply with UL or CSA Standards, make sure the temperature rise of the windings is 50°C or less, by mounting the motor to a heat sink (material: aluminum) of the following size. RBK26□T : 400×400 mm, 10 mm thick RBK29□T : 200×200 mm, 10 mm thick	-
Stop Position Accuracy ^{*1}		±3 arc minutes (±0.05°)	-
Shaft Runout		0.05 mm T.I.R. ^{*4}	-
Radial Play ^{*2}		0.025 mm max. of 5 N	-
Axial Play ^{*3}		0.075 mm max. of 10 N	-
Concentricity		0.075 mm T.I.R. ^{*4}	-
Perpendicularity		0.075 mm T.I.R. ^{*4}	-

*1 This value is for full step under no load. (The value changes with the size of the load.)

*2 Radial Play: Displacement in shaft position in the radial direction, when a 5 N load is applied in the vertical direction to the tip of the motor's shaft.

*3 Axial Play: Displacement in shaft position in the axial direction, when a 10 N load is applied to the motor's shaft in the axial direction.

*4 T.I.R. (Total Indicator Reading): The total dial gauge reading when the measurement section is rotated one revolution centered on the reference axis center.

Note:

- Do not measure insulation resistance or perform the dielectric strength test while the motor and driver are connected.

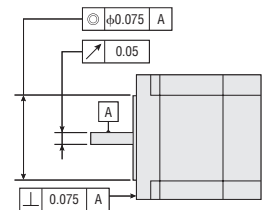

Permissible Overhung Load and Permissible Thrust Load

Model	Permissible Overhung Load [N] Distance from Shaft End [mm]					Permissible Thrust Load*
	0	5	10	15	20	
RBK264T						0.6
RBK266T	54	67	89	130	-	0.9
RBK268T						1.2
RBK296T						2.1
RBK299T	260	290	340	390	480	3.2
RBK2913T						4.3

* The permissible thrust load is equal to the motor mass (unit: kg). Make sure the thrust load is no greater than the motor mass.

Dimensions (Unit = mm)

Motor

1 □ 56.4 mm

Model	Motor Model	L	Mass kg
RBK264T	PK264D1T	83	0.6
RBK266T	PK266D1T	98	0.9
RBK268T	PK268D1T	120	1.2

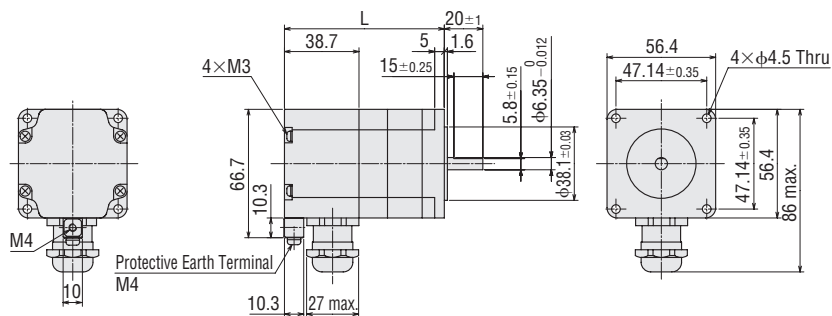

● Use cable (VCT) with a diameter of $\phi 7 \sim \phi 13$ mm. The cable must be purchased separately.

2 □ 85 mm

Model	Motor Model	L	Mass kg
RBK296T	PK296DT	110	2.1
RBK299T	PK299DT	140	3.2
RBK2913T	PK2913DT	170	4.3

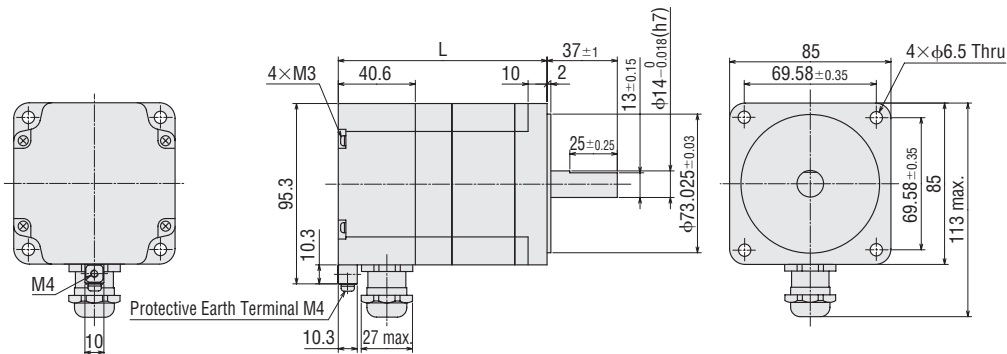

● Use cable (VCT) with a diameter of $\phi 7 \sim \phi 13$ mm. The cable must be purchased separately.

Driver

3 Driver Model: RBD242A-V, RBD245A-V

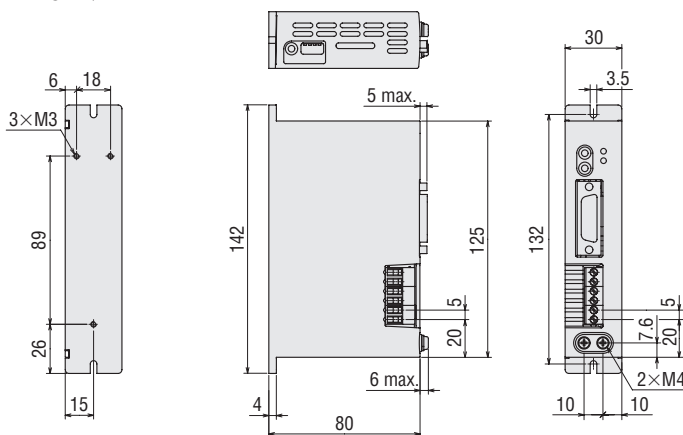

Connection and Operation

Names and Functions of Driver Parts

(Top)



[2] Function Switch, Motor Stop Current Switch

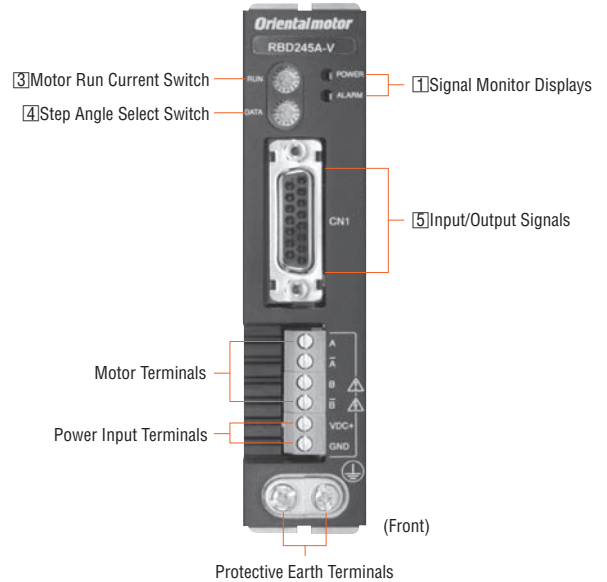

[1] Signal Monitor Display

◇ LED Indicators

Indication	Color	Function
POWER	Green	Power input display
ALARM	Red	Alarm signal output display

◇ Alarm

Blink Count	Function	Condition
2	Overheat	The driver temperature exceeded the specified value.
3	Overvoltage	The primary voltage of the driver's inverter exceeded the permissible value.
5	Overcurrent	An excessive current has flowed to the driver's inverter.

[2] Function Switch, Motor Stop Current Switch

Indication	Switch Name	Function
SW1	Third Harmonic Waveform Correction Function Select Switch	A function that provides improved angle accuracy and reduced vibrations by optimizing the motor drive current waveforms. You can set the correction value using the select switch.
SW2-1	Smooth Drive Function Switch	Low vibration and low noise operation are available even in the low speed range without changing the step angle setting. The function can be set and deactivated with this switch.
SW2-2	Vibration Suppression Function Select Switch	A function that provides reduced vibrations at medium speed operation. The function can be set or deactivated with this switch.
SW2-3	Not used.	—
SW2-4	Motor Stop Current Switch	For adjusting the current at motor standstill

[3] Motor Run Current Switch

Indication	Switch Name	Function
RUN	Motor Run Current Switch	For adjusting the motor running current

[5] Input/Output Signal

Indication	Input/Output	Pin No.	Signal	Content	Function
CN1*	Input	1	PLS+	Pulse Signal	Operation command pulse signal
		2	PLS24+		
		9	PLS-		
		3	DIR+	Rotation Direction Signal	
		10	DIR24+		
		11	DIR-		
	Output	4	AWO	All Windings Off Signal	Cuts the output current to the motor and allows the motor shafts to be rotated by external force.
		12	CS	Step Angle Select Signal	Operates with the basic step angle, regardless of the DATA setting.
		5	IN-COM	Input Common	Input common for the All Windings Off signal and Step Angle Select signal.
		13	CD+	Current Cutback Signal	Outputs a signal when the automatic current cutback function activates.
		6	CD-		
14	ALM+	Alarm Signal	Turns the output off when one of the driver's protective functions is activated.		
7	ALM-				
15	TIM+	Excitation Timing Signal	Outputs signals when the excitation sequence is at STEP "0."		
8	TIM-				

*The cable for connecting the motor and driver, and the D-Sub (15-pin) connector for connecting to the driver's CN1 connector are not included. They must be purchased separately.

Description of input/output signals → Page 12

[4] Step Angle Setting Switch

Indication	Switch Name	Function
DATA	Step Angle Setting Switch	The switch can be set to the desired resolution from the 16 resolution levels.

Step Angle Setting Switch	Microstep/Step	Resolution	Step Angle
0	1	200	1.8°
1	2	400	0.9°
2	4	800	0.45°
3	5	1000	0.36°
4	8	1600	0.225°
5	9	1800	0.2°
6	10	2000	0.18°
7	16	3200	0.1125°
8	18	3600	0.1°
9	20	4000	0.09°
A	32	6400	0.05625°
B	36	7200	0.05°
C	40	8000	0.045°
D	64	12800	0.028125°
E	80	16000	0.0225°
F	128	25600	0.0140625°

- The step angle set with the step angle setting switch is enabled when the step angle select (CS) signal input turns off.
- Do not change the step angle select signal input or step angle setting switch while the motor is running. This may cause the motor to misstep and stop. Set the step angle setting switch when the step angle select signal input is turned off, and the excitation timing output is turned on.

● Connection Diagrams

◇ 5 VDC Connection or Line Driver Input

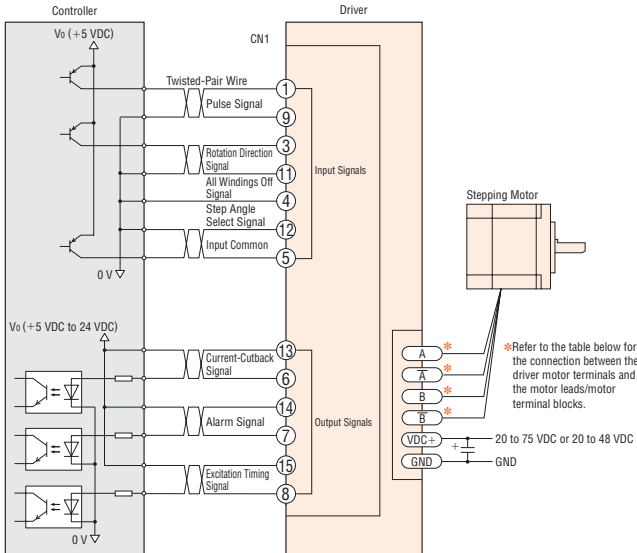

◇ 24 VDC Connection

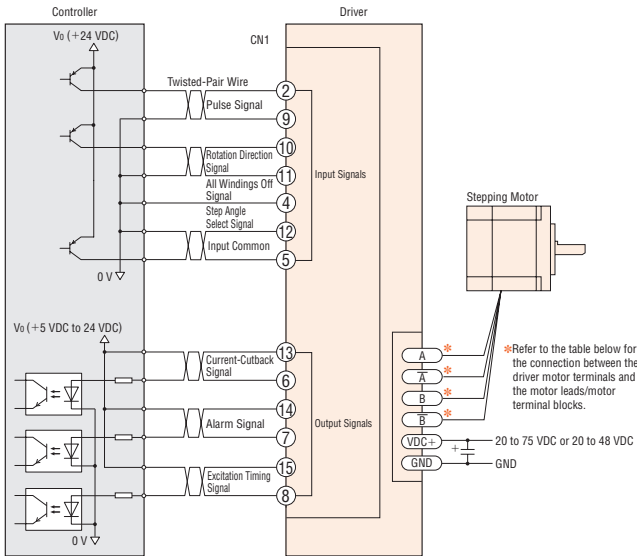

◇ Pulse (PLS) and Rotation Direction (DIR) Input Signal Connections

You can select either 5 VDC or 24 VDC as the signal voltage for PLS input and DIR input. Line driver input is also available. The pin No. to connect differs according to the signal voltage.

◇ All Windings Off (AWO) and Step Angle Select (CS) Input Signal Connections

You can select either 5 VDC or 24 VDC as the signal voltage. The pin No. to connect is the same for 5 VDC and 24 VDC.

◇ Connecting Output Signal

Keep the output signal voltage and current below 30 VDC and 10 mA respectively.

◇ Power Supply

Use a power supply that can supply sufficient input current. When power supply capacity is insufficient, a decrease in motor output can cause the following malfunctions:

- Motor does not operate properly at high-speed.
- Slow motor startup and stopping.

◇ Notes on Wiring

- Use twisted-pair wires of AWG26 (0.14 mm²) or thicker and 2 m or less in length for the signal lines.
- Note that as the length of the pulse signal line increases, the maximum transmission frequency decreases.
- Use wires of AWG18 (0.75 mm²) or thicker for motor lines (when extended), power supply lines, and protective earthing line.
- To ground the driver, lead the ground conductor from the protective earth terminal (M4) and connect the ground conductor to provide a common ground point.
- Signal lines should be kept at least 2 cm away from power lines (power supply lines and motor lines). Do not bind the signal lines and power lines together.
- If noise generated by the motor cable or power cable becomes a problem due to the wiring and layout, shield the cables or use ferrite cores.
- Incorrect connection of DC power input will lead to driver damage. Make sure that the polarity is correct before turning power on.
- The cable for connecting the motor and driver, and the D-Sub (15-pin) connector for connecting to the driver's CN1 connector are not included. They must be purchased separately.

·Driver Motor Terminals and Motor Leads/Motor Terminal Blocks

Signal Name	Content	Terminal Block No. for RBK26□	Terminal Block No. for RBK29□
A	A-Phase Output	2	1
\bar{A}	\bar{A} -Phase Output	3	4
B	B-Phase Output	4	5
\bar{B}	\bar{B} -Phase Output	5	8

◇ Motor Connections

RBK264T, RBK266T, RBK268T

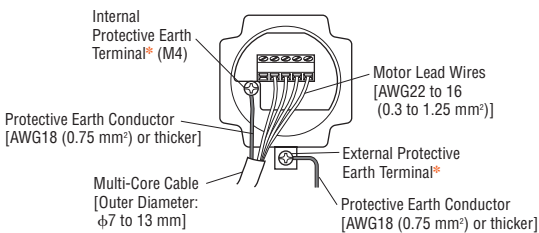

* Connect either the internal protective earth terminal or external protective earth terminal to the ground.

RBK296T, RBK299T, RBK2913T

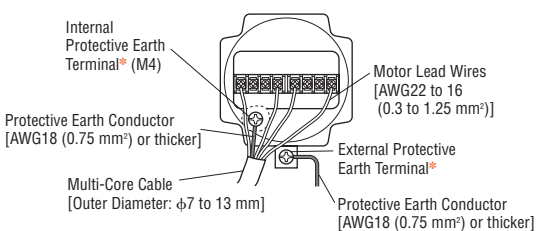

* Connect either the internal protective earth terminal or external protective earth terminal to the ground.

Connect motor lead wires to the terminals 2 to 5.

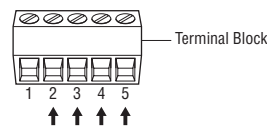

Terminals 1, 4, 5, and 8 are used. Terminals 2, 3, 6, and 7 are not used. Do not connect anything to them.

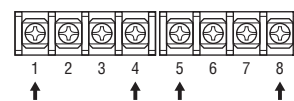

● Description of Input/Output Signals

Indication of Input/Output Signal "ON" "OFF"
 Input (Output) "ON" indicates that the current is sent into the photocoupler (transistor) inside the driver. Input (Output) "OFF" indicates that the current is not sent into the photocoupler (transistor) inside the driver.
 The input/output remains "OFF" if nothing is connected.

Photocoupler OFF ON

Pulse (PLS), Rotation Direction (DIR) Input Signal

You can select either 5 VDC or 24 VDC as the signal voltage for PLS input and DIR input. Line driver input is also available.

◇ Input Circuit and Sample Connection

● 5 VDC Connection

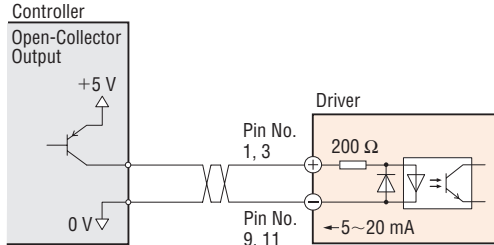

● 24 VDC Connection

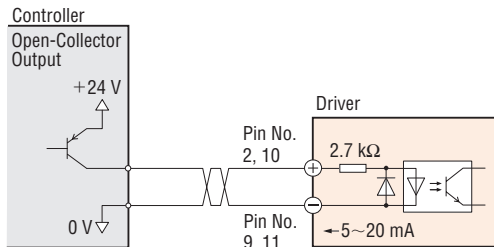

● Line Driver Input

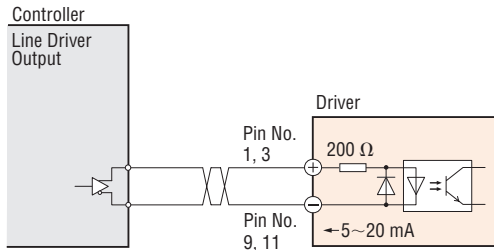

◇ Pulse Waveform

● 5 VDC or 24 VDC Connection

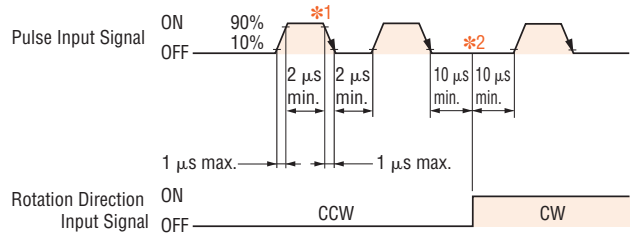

● Pulse duty: 50% and below

● Line Driver Input

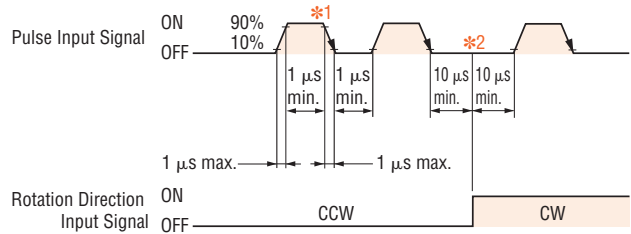

● Pulse duty: 50% and below

- *1 The shaded area indicates when the photocoupler diode is ON. The motor moves when the photocoupler state changes from ON to OFF.
- *2 The minimum interval time when changing rotation direction 10 μs is shown as a response time of circuit. This value varies greatly depending on the motor type and load inertia.

◇ Pulse Signal Characteristics

- Keep the pulse signal at the "photocoupler OFF" state when no pulses are being input.
- Leave the pulse signal at rest ("photocoupler OFF") when changing rotation directions.

All Windings Off (AWO), Step Angle Select (CS) Signal Input

◇ Input Circuit and Sample Connection

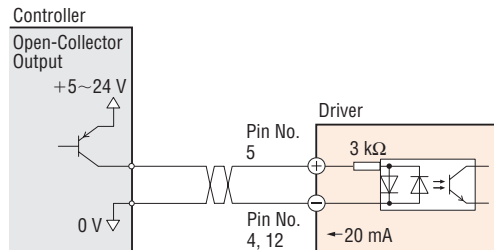

◇ All Windings Off (AWO) Input Signal

- Inputting this signal puts the motor in a non-excitation (free) state.
- This signal is used when turning the motor by external force or manual home position is desired. The photocoupler must be "OFF" when operating the motor.

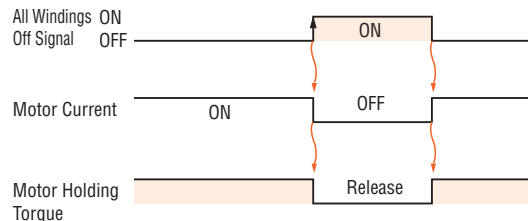

- Switching the "All Windings Off" signal from "photocoupler ON" to "photocoupler OFF" does not alter the excitation sequence. When the motor shaft is manually adjusted with the "AWO" signal input, the shaft will shift up to $\pm 3.6^\circ$ from the position set after the "AWO" signal is released.

◇ Step Angle Select (CS) Input Signal

- When the signal is at "photocoupler ON," the motor operates with the basic step angle, regardless of the setting of the step angle setting switch. When the signal is at "photocoupler OFF," the motor operates with the step angle set with the step angle setting switch.
- When changing the step angle, make sure the "Excitation Timing" signal output is turned on and the motor is at standstill.

Current Cutback (CD), Alarm (ALM), Timing (TIM) Output Signal

◇ Output Circuit and Sample Connection

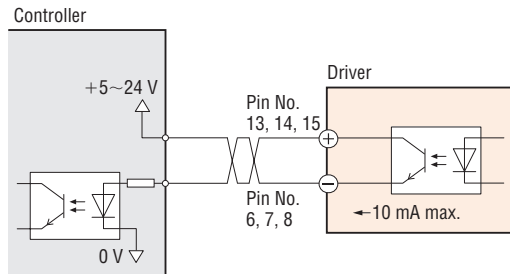

◇ Current Cutback (CD) Output Signal

- When the automatic current cutback function is activated, the CD output turns on.

◇ Alarm (ALM) Output Signal

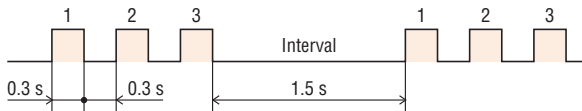

- When the motor is running, if the driver overheat, overvoltage, or overcurrent protective function is detected, the ALM output turns off, and the ALARM LED of the driver flashes. The current to the motor is also cut off to stop the motor.
- You can count the number of times the ALARM LED flashes to confirm which protective function is activated.
- This signal normally stays on, but turns off when a protective function is activated.

● Timing Chart

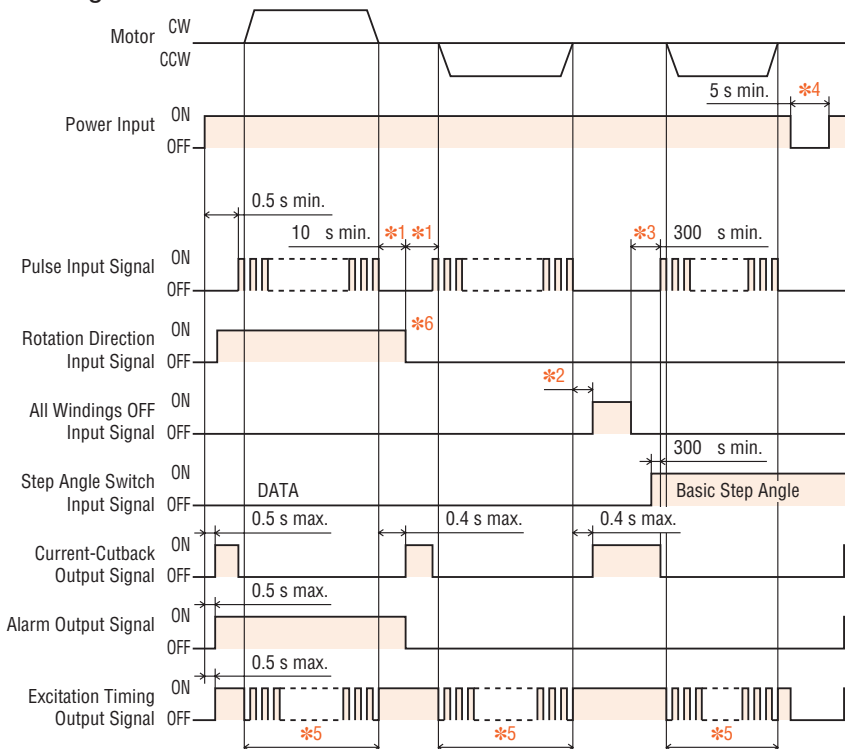

The shaded section indicates that the photocoupler diode is emitting light.

◇ Timing (TIM) Output Signal

- The "Excitation Timing" signal is output to indicate when the motor excitation (current flowing through the winding) is in the initial stage (step "0" at power up).
 - The "Excitation Timing" signal is output simultaneously with a pulse input each time the excitation sequence returns to step "0." The excitation sequence will complete one cycle for every 7.2° rotation of the motor output shaft.
- Resolution 1: Signal is output once every 4 pulses.
Resolution 4: Signal is output once every 16 pulses.

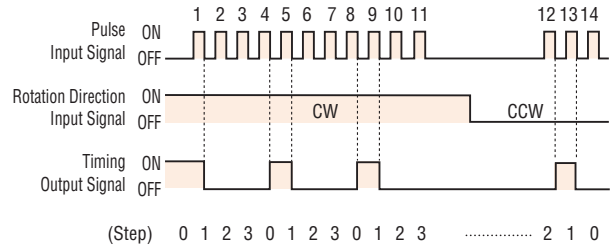

Notes:

- When power is turned ON, the excitation sequence is reset to step "0" and the "Excitation Timing" signal is output.
- When using the "Excitation Timing" signal output, operate the motor so that its output shaft stops at an integral multiple of 7.2°.

- *1 The switching time to change direction 10 μs is shown as the response time of the circuit. The motor may need more time.
- *2 Depends on load inertia, load torque, and starting frequency.
- *3 Never input a step pulse signal immediately after switching the "All Windings Off" signal input to the "OFF" state. The motor may not start.
- *4 To cycle the power, turn off the power and then wait for at least five seconds after the POWER LED has turned off.
- *5 "Excitation Timing" signal is output once every 7.2° rotation of the motor output shaft.
- *6 The minimum interval time needed for switching the direction of rotation will vary, depending on the operating speed and size of the load. Do not shorten the interval time any more than is necessary.

List of Motor and Driver Combinations

Model names for motor and driver combinations are shown below.

Model	Motor Model	Driver Model
RBK264T	PK264D1T	RBD242A-V
RBK266T	PK266D1T	RBD242A-V
RBK268T	PK268D1T	RBD242A-V
RBK296T	PK296DT	RBD245A-V
RBK299T	PK299DT	RBD245A-V
RBK2913T	PK2913DT	RBD245A-V

Flexible Couplings (Sold separately) RoHS

A flexible coupling ideal for your motor is available. Once you have decided on a motor and gear, you can select the recommended coupling easily. All motor shaft diameters are available.



Features of MCS Couplings

This three-piece coupling adopts an aluminum alloy hub and a resin spider. The simple construction ensures that the high torque generated by a geared motor can be transmitted reliably. The proper elasticity of the spider suppresses motor vibration.

- A spider (material: polyurethane) controls the vibration generated by the motor.
- No backlash

Product Number Code

MCS 30 6 F04

① ② ③ ④

①	MCS Couplings
②	Outer Diameter of Coupling
③	Inner Diameter d1 (Smaller Side) (F04 represents $\phi 6.35$ mm)
④	Inner Diameter d2 (Larger Side) (F04 represents $\phi 6.35$ mm)

Coupling Selection Table

Applicable Motor Model	Motor Shaft Diameter (mm)	Coupling Model	Connected Device Shaft Diameter (mm)
RBK264T RBK266T	$\phi 6.35$	MCS2005F04	$\phi 5$
		MCS2006F04	$\phi 6$
		MCS20F04F04	$\phi 6.35$
		MCS20F0408	$\phi 8$
		MCS20F0410	$\phi 10$
RBK268T	$\phi 6.35$	MCS3006F04	$\phi 6$
		MCS30F04F04	$\phi 6.35$
		MCS30F0408	$\phi 8$
		MCS30F0410	$\phi 10$
RBK296T	$\phi 14$	MCS301014	$\phi 10$
		MCS301214	$\phi 12$
		MCS301414	$\phi 14$
		MCS301416	$\phi 16$
RBK299T RBK2913T	$\phi 14$	MCS551214	$\phi 12$
		MCS551414	$\phi 14$
		MCS551415	$\phi 15$
		MCS551416	$\phi 16$

Mounting Brackets (Sold separately) RoHS

Mounting brackets are convenient for installation and securing a stepping motor.



Product Line

Material: Aluminum alloy

Model	Applicable Product
PAL2P-2	RBK264T, RBK266T, RBK268T
PAL4P-2	RBK296T, RBK299T, RBK2913T

- The mounting bracket base is built with holes large enough to allow for alignment adjustments in the horizontal direction.
- These mounting brackets can be perfectly fitted to the pilot of the stepping motors.

DIN Rail Mounting Plate (Sold separately) RoHS

(Available when the input voltage to the driver is 48 VDC or less)

This mounting plate is convenient for installing the driver of **RBK** Series on DIN rails with ease.

Note:

- If the driver's input power-supply voltage exceeds 48 VDC, do not install the driver onto a DIN rail. Sufficient heat dissipation cannot be achieved and the driver's overheat protective function may be activated as a result. In such a case, install the driver onto a metal plate directly.

Model: **PADP01**



Controller (Sold separately)

Controller for Stepping Motor **SG8030JY** RoHS

All operations including data setting can easily be performed using the four touch pads on the top panel. In addition, the number of signal lines is reduced to a minimum for easy connection.

- Jerk limiting control function suppresses motor drive vibrations
- Sequential-step positioning operation/external signal operation possible
- Maximum oscillating frequency of 200 kHz
- 1-pulse output/2-pulse output mode select possible



DIN Rail Mounting Model



Recessed Mounting Model

Product Line

Type	Model
DIN Rail Mounting Model	SG8030JY-D
Recessed Mounting Model	SG8030JY-U

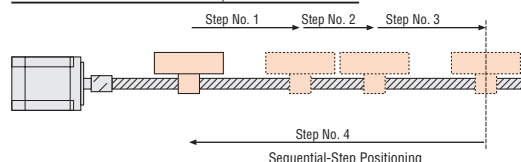

This product is manufactured at a plant certified with the international standards **ISO 9001** (for quality assurance) and **ISO 14001** (for systems of environmental management).

Specifications are subject to change without notice.
This catalogue was published in May, 2007.

Orientalmotor

ORIENTAL MOTOR (EUROPA) GmbH

www.orientalmotor.de

European Headquarters and Düsseldorf Office

Schießstraße 74
40549 Düsseldorf, Germany
Tel: 0211-5206700 Fax: 0211-52067099

Munich Office

Liebigstraße 14
85757 Karlsfeld, Germany
Tel: 08131-59880 Fax: 08131-598888

Hamburg Office

Meckelfelder Weg 2
21079 Hamburg, Germany
Tel: 040-76910443 Fax: 040-76910445

Jena Office

Wildenbruchstr 15
07745 Jena, Germany
Tel: 03641-675280 Fax: 03641-675288

Stuttgart Office

Tel: 07335-924853 Fax: 07335-924854

Customer Center (Support in German & English)

00800 22 55 66 22*
CALL OM CC

tech@orientalmotor.de

ORIENTAL MOTOR (UK) LTD.

www.oriental-motor.co.uk

Unit 5, Faraday Office Park,
Rankine Road, Basingstoke,
Hampshire RG24 8AH U.K.
Tel: 01256-347090 Fax: 01256-347099

ORIENTAL MOTOR (FRANCE) SARL

www.orientalmotor.fr

France Headquarters

32, Avenue de l'île Saint Martin
92737 Nanterre Cedex, France
Tel: 01 47 86 97 50 Fax: 01 47 82 45 16

Lyon Office

10, Allée des Sorbiers
69673 Bron Cedex, France
Tel: 04 78 41 15 02 Fax: 04 78 41 15 90

ORIENTAL MOTOR ITALIA s.r.l.

www.orientalmotor.it

Italy Headquarters

Via A. De Gasperi, 85
20017 Mazzo di Rho (MI), Italy
Tel: 02-93906346 Fax: 02-93906348

Bologna Office

Via mori, 6
40054 Prunaro di Budrio (BO), Italy
Tel: 051-6931249 Fax: 051-6929266

ORIENTAL MOTOR CO., LTD.

www.orientalmotor.co.jp

Headquarters

16-17, Ueno 6-chome
Taito-ku, Tokyo 110-8536, Japan
Tel: (03)3835-0684 Fax: (03)3835-1890

For more information please contact: