

RoHS RoHS-Compliant

2-Phase Stepping Motor and Driver Package

CMK Series

● Additional Information ●
 Technical reference → Page F-1

The **CMK** Series is a motor and driver package consisting of a 2-phase stepping motor and 24 VDC input micro step driver, allowing for a reduction in the size of your equipment and in vibration.

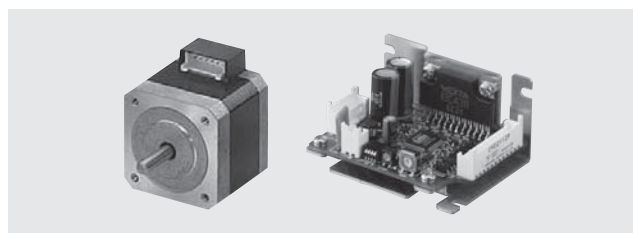

Features

● Achieving Low Vibration and Noise in the Microstep Drive

The newly designed compact DC board-level driver achieves microstep drive in a compact, lightweight body. The 2-phase stepping motor's basic step angle (1.8°/step) is divided by a maximum of 16 resolutions (0.1125°/step) without the use of a reduction mechanism or other mechanical elements, which contributes to the reduction in noise and vibration of your equipment.

Microstep/Step	Resolution	Step Angle
1	200	1.8°
2	400	0.9°
4	800	0.45°
8	1600	0.225°
16	3200	0.1125°

(At basic step angle 1.8°/step)

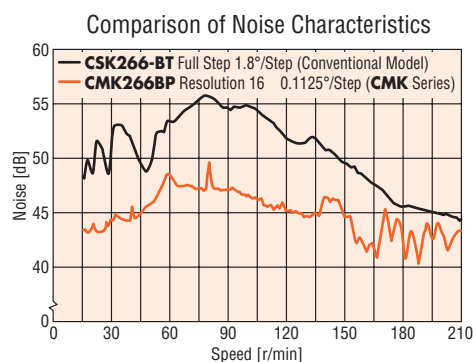
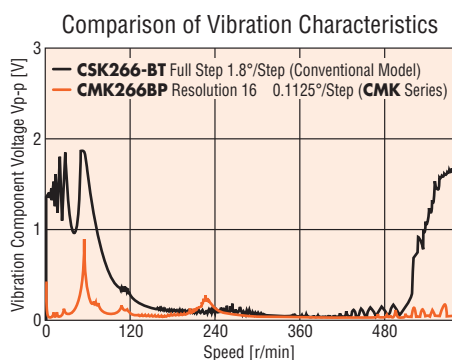

● Full Range of Driver Functions

- Five preset step angles
- Operating current can easily be set with a digital switch
- 1-pulse/2-pulse input mode switching
- Power LED
- Connector with lock (by MOLEX)

◇ Easy-to-Install Heat Sink Shape

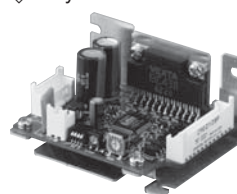

Horizontal Installation

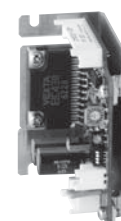

Vertical Installation

● One of the Smallest Drivers in the Industry Adopting a Microstep Driver

The driver of the **CMK** Series is one of the smallest, lightest drivers in the industry adopting a microstep driver. The driver is 62% lighter and has 41% less install area (based on horizontal installation) compared to our conventional model. This product contributes to downsizing of your equipment.

Mass: 130 g

Mass: 50 g

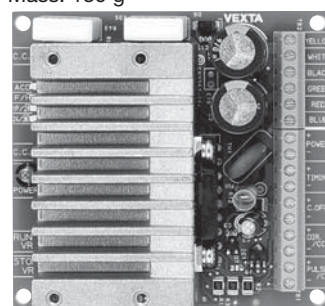
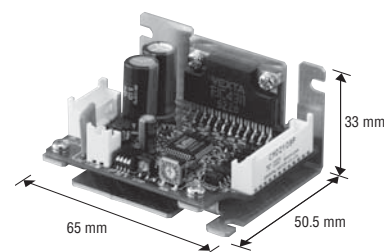

Conventional Model (CSD2120-T)













New Product (CMD21□□P)

Comparison with a conventional driver

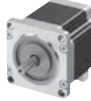
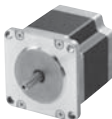
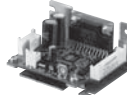
- ◇ Mass: **62%** less
- ◇ Install area: **41%** less (based on horizontal installation)
- ◇ Volume: **41%** less (the conventional driver includes a 5 mm spacer for installation.)

● Wide Variety

The **CMK** Series motor and driver package comes in five frame sizes of 28 to 60 mm as well as four motor types.

Type	Features	□28 mm	□35 mm	□42 mm	□50 mm	□56.4/60 mm	Driver
High-Torque Type	The high-torque motor realized higher torque of approx. 1.5 times compared with the conventional standard type motor.						
Standard Type	The basic model offering a good balance of torque and low vibration/noise characteristics.						
High-Resolution Type	High-torque motor offering higher positioning accuracy with the basic step angle set to 0.9°/step, which is just half the basic step angle of the standard type motor.						
SH Geared Type	These geared types are effective for reduction, increasing torque, higher resolution and suppressing vibration. Eight gear ratios are available.						

● High-Torque Type

The high-torque type adopts new technology and design. This motor produces higher torque of approximately 1.5 times the level achieved by a conventional standard type motor.

Comparison of Speed–Torque Characteristics

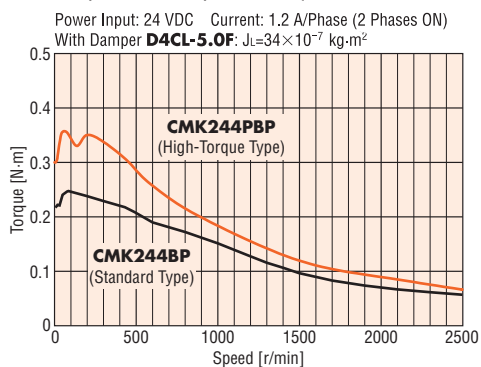

Providing torque equivalent to a motor of the next larger frame size, the high-torque type allows for a reduction in the size of your equipment.

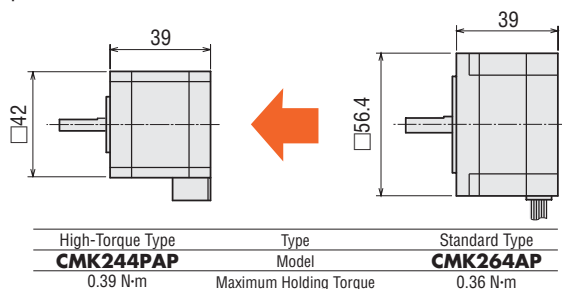

The motor also adopts a connector coupling system for easy installation.

● (RoHS) RoHS-Compliant

The **CMK** Series conforms to the RoHS Directive that prohibits the use of six chemical substances including lead and cadmium.

● Details of RoHS Directive → Page G-23

● High-Resolution Type

The basic step angle is 0.9°, which is half that of the standard type. 400 steps per rotation is possible. This motor achieves high resolution, low vibration and improved stopping accuracy.

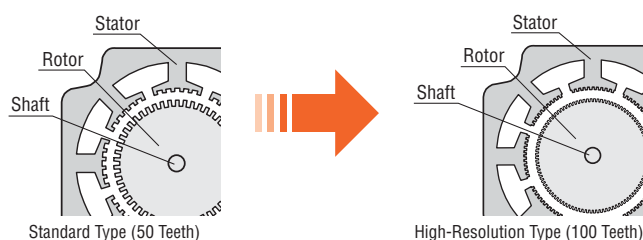

The small basic step angle allows the torque to pick up quickly while minimizing the negative effect of friction load.

Comparison of Angle–Torque Characteristics

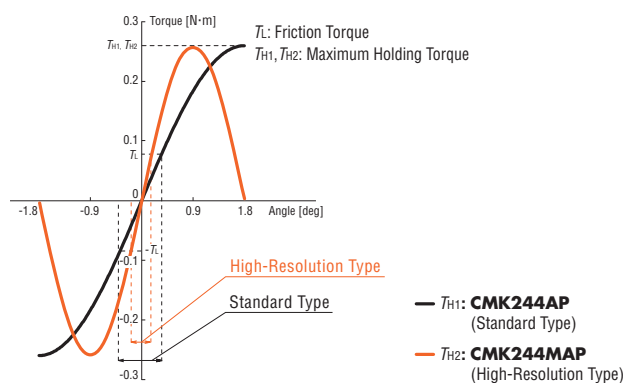

System Configuration

An example of a system configuration with the **SG8030JY** controller.

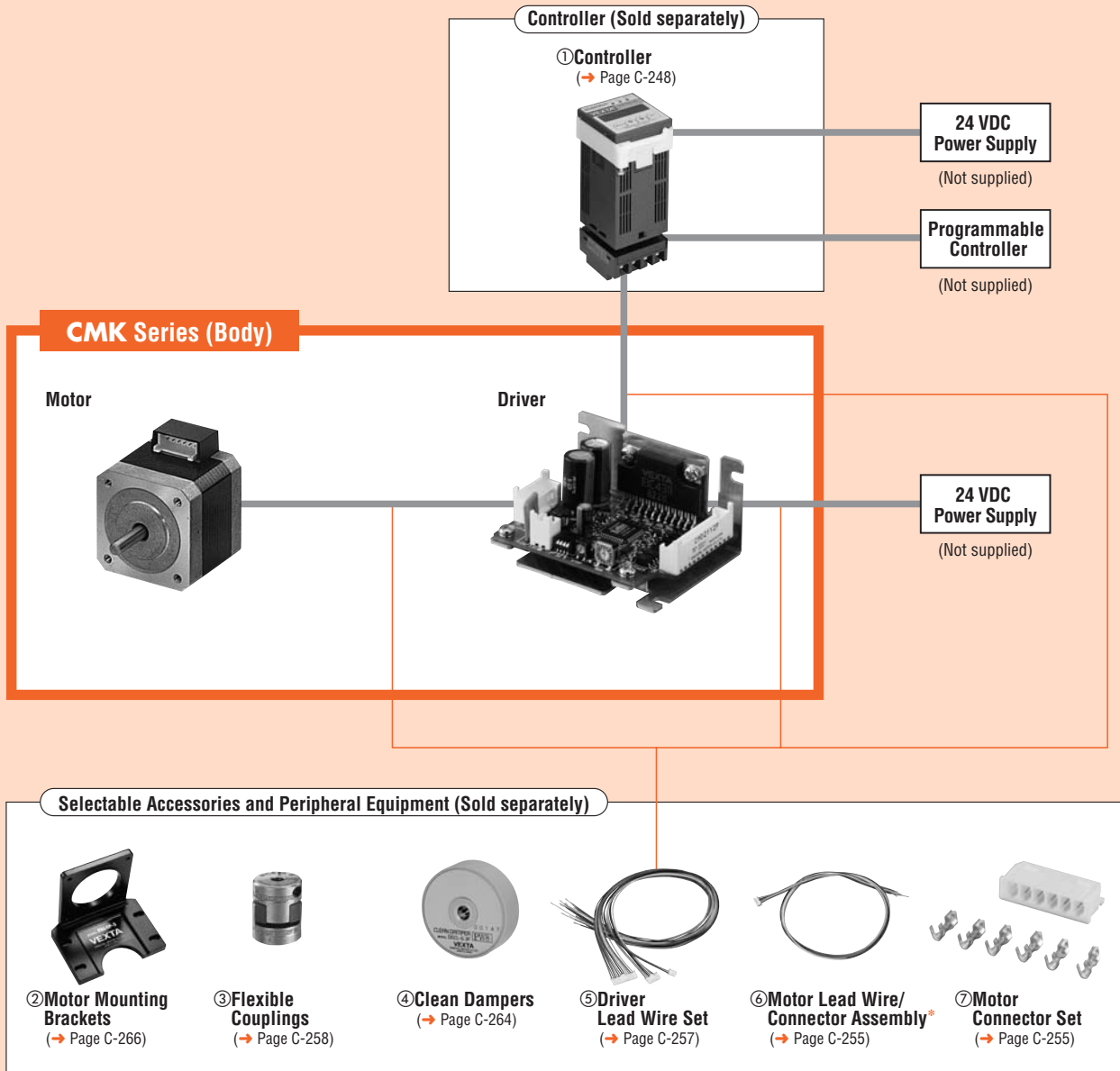

*Motor lead wire/connector assembly of 0.6 m is included with the motor and driver package of connector-coupled type.

No.	Product Name	Overview	Page
①	Controller	This controller outputs pulse commands that determine the rotating amount and rotating speed.	C-248
②	Motor Mounting Brackets	Dedicated mounting bracket for the motor.	C-266
③	Flexible Couplings	Coupling that connects the motor shaft to the driven shaft.	C-258
④	Clean Dampers	Dedicated damper for suppressing stepping motor vibration.	C-264
⑤	Driver Lead Wire Set	Cables for connecting the driver and motor, DC power supply or host controller (0.6 m).	C-257
⑥	Motor Lead Wire/Connector Assembly	Lead wire with a connector crimped for connector-coupled motors (0.6 m, 1 m).	C-255
⑦	Motor Connector Set	Set of connector housings and contacts for use with connector-coupled motors (for 30 units).	C-255

Example of System Configuration

(Body)

(Sold separately)

CMK Series	+	Controller	Motor Mounting Bracket	Flexible Coupling	Clean Damper	Driver Lead Wire Set (0.6 m)
CMK244BPB		SG8030JY-U	PALOP	MCS140506	D4CL-5.0F	LCS01CMK2

●The system configuration shown above is an example. Other combinations are available.

Product Number Code

- High-Torque Type, Standard Type, High-Resolution Type

CMK 2 4 6 P A P

① ② ③ ④ ⑤ ⑥ ⑦

①	Series	CMK: CMK Series		
②	2: 2-Phase			
③	Motor Frame Size	2: 28 mm	3: 35 mm	4: 42 mm 5: 50 mm 6: 56.4 mm
④	Motor Case Length			
⑤	Motor Type	P: High-Torque Type Blank: Standard Type M: High-Resolution Type		
⑥	Shaft Type	A: Single Shaft B: Double Shaft		
⑦	Signal I/O Mode	P: Photocoupler		

- SH Geared Type

CMK 2 6 4 A P - SG 10

① ② ③ ④ ⑤ ⑥ ⑦ ⑧

①	Series	CMK: CMK Series		
②	2: 2-Phase			
③	Motor Frame Size	2: 28 mm	4: 42 mm	6: 60 mm
④	Motor Case Length			
⑤	Shaft Type	A: Single Shaft B: Double Shaft		
⑥	Signal I/O Mode	P: Photocoupler		
⑦	Gearhead Type	SG: SH Geared Type		
⑧	Gear Ratio			

Product Line

- High-Torque Type

Model (Single Shaft)	Model (Double Shaft)
CMK223PAP	CMK223PBP
CMK224PAP	CMK224PBP
CMK225PAP	CMK225PBP
CMK233PAP	CMK233PBP
CMK235PAP	CMK235PBP
CMK244PAP	CMK244PBP
CMK246PAP	CMK246PBP

The following items are included in each product.
Motor, Driver, Driver Connector, Motor Lead Wire/Connector Assembly, Operating Manual

- Standard Type

Model (Single Shaft)	Model (Double Shaft)
CMK243AP	CMK243BP
CMK244AP	CMK244BP
CMK245AP	CMK245BP
CMK256AP	CMK256BP
CMK258AP	CMK258BP
CMK264AP	CMK264BP
CMK266AP	CMK266BP
CMK268AP	CMK268BP

The following items are included in each product.
Motor, Driver, Driver Connector, Operating Manual

- High-Resolution Type

Model (Single Shaft)	Model (Double Shaft)
CMK243MAP	CMK243MBP
CMK244MAP	CMK244MBP
CMK245MAP	CMK245MBP
CMK264MAP	CMK264MBP
CMK266MAP	CMK266MBP
CMK268MAP	CMK268MBP

The following items are included in each product.
Motor, Driver, Driver Connector, Motor Lead Wire/Connector Assembly, Operating Manual

- SH Geared Type

Model (Single Shaft)	Model (Double Shaft)
CMK223AP-SG7.2	CMK223BP-SG7.2
CMK223AP-SG9	CMK223BP-SG9
CMK223AP-SG10	CMK223BP-SG10
CMK223AP-SG18	CMK223BP-SG18
CMK223AP-SG36	CMK223BP-SG36
CMK243AP-SG3.6	CMK243BP-SG3.6
CMK243AP-SG7.2	CMK243BP-SG7.2
CMK243AP-SG9	CMK243BP-SG9
CMK243AP-SG10	CMK243BP-SG10
CMK243AP-SG18	CMK243BP-SG18
CMK243AP-SG36	CMK243BP-SG36
CMK243AP-SG50	CMK243BP-SG50
CMK243AP-SG100	CMK243BP-SG100
CMK264AP-SG3.6	CMK264BP-SG3.6
CMK264AP-SG7.2	CMK264BP-SG7.2
CMK264AP-SG9	CMK264BP-SG9
CMK264AP-SG10	CMK264BP-SG10
CMK264AP-SG18	CMK264BP-SG18
CMK264AP-SG36	CMK264BP-SG36
CMK264AP-SG50	CMK264BP-SG50
CMK264AP-SG100	CMK264BP-SG100

The following items are included in each product.
Motor, Driver, Driver Connector, Motor Lead Wire/Connector Assembly*, Mounting Screws for Motor, Operating Manual
*Only for connector-coupled motor

High-Torque Type Motor Frame Size 28 mm

Specifications RoHS

Model	Single Shaft	CMK223PAP*	CMK224PAP*	CMK225PAP*
	Double Shaft			
Maximum Holding Torque	N·m	0.05	0.075	0.09
Rotor Inertia	J: kg·m ²	9×10^{-7}	12×10^{-7}	18×10^{-7}
Rated Current	A/Phase	0.95		
Basic Step Angle		1.8°		
Power Source		24 VDC ± 10% 1.5 A		
Excitation Mode		Microstep		
Mass	Motor kg	0.11	0.14	0.2
	Driver kg			
Dimension No.	Motor	T1		
	Driver	T10		

How to read specifications table → Page C-10

* Motor lead wire/connector assembly of 0.6 m is included with the motor and driver package of connector coupled type.

Speed – Torque Characteristics How to read speed – torque characteristics → Page C-10

CMK223PAP/CMK223PBP

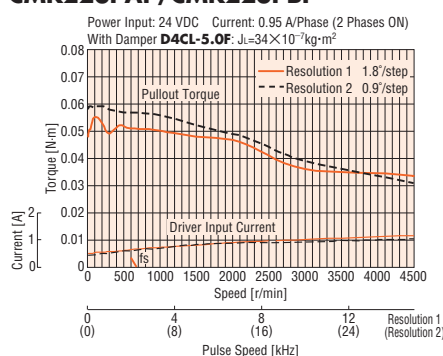

CMK224PAP/CMK224PBP

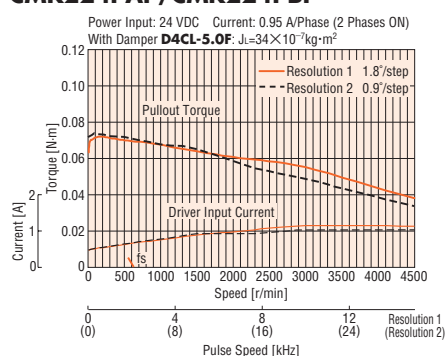

CMK225PAP/CMK225PBP

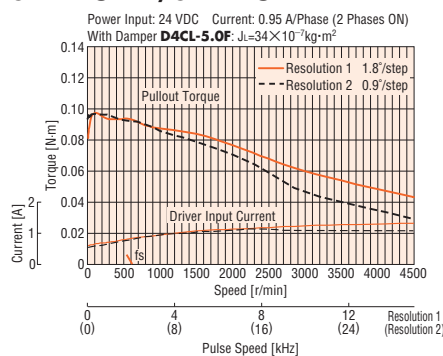

● The pulse input circuit responds to approximately 100 kHz with a pulse duty of 50%.

Notes:

- Pay attention to heat dissipation from motor as there will be a considerable amount of heat under certain conditions. Be sure to keep the temperature of the motor case under 100°C.
- The driver's automatic current cutback function at motor standstill reduces maximum holding torque by approximately 40%.

High-Torque Type Motor Frame Size 35 mm, 42 mm

Specifications RoHS

Model	Single Shaft	CMK233PAP*	CMK235PAP*	CMK244PAP*	CMK246PAP*	
	Double Shaft	CMK233PBP*	CMK235PBP*	CMK244PBP*	CMK246PBP*	
Maximum Holding Torque	N·m	0.16	0.3	0.39	0.75	
Rotor Inertia	J: kg·m ²	24×10 ⁻⁷	50×10 ⁻⁷	57×10 ⁻⁷	114×10 ⁻⁷	
Rated Current	A/Phase	1.2				
Basic Step Angle		1.8°				
Power Source		24 VDC±10% 1.7 A				
Excitation Mode		Microstep				
Mass	Motor	kg	0.18	0.285	0.3	0.5
	Driver	kg	0.05			
Dimension No.	Motor	[2]		[3]		
	Driver	[10]				

How to read specifications table → Page C-10

* Motor lead wire/connector assembly of 0.6 m is included with the motor and driver package of connector coupled type.

Speed – Torque Characteristics How to read speed – torque characteristics → Page C-10

CMK233PAP/CMK233PBP

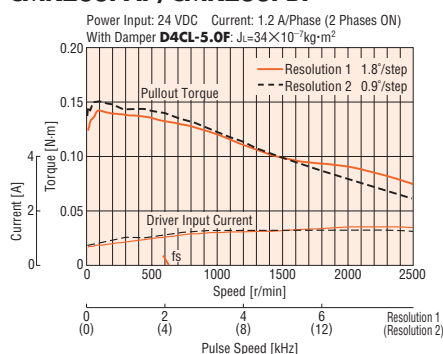

CMK235PAP/CMK235PBP

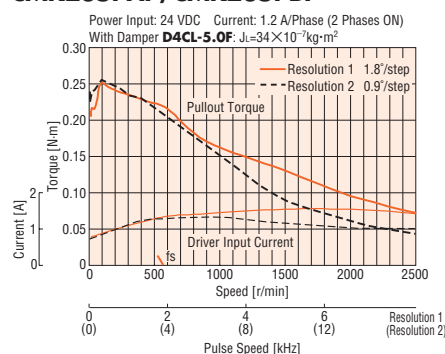

CMK244PAP/CMK244PBP

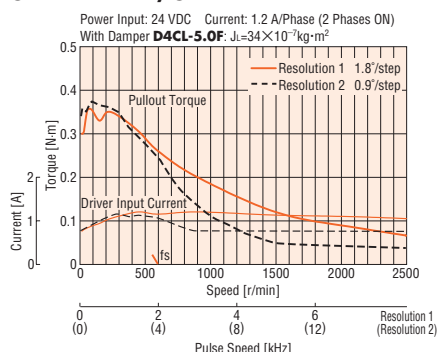

CMK246PAP/CMK246PBP

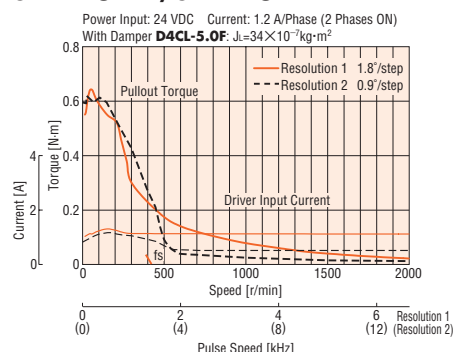

● The pulse input circuit responds to approximately 100 kHz with a pulse duty of 50%.

Notes:

- Pay attention to heat dissipation from motor as there will be a considerable amount of heat under certain conditions. Be sure to keep the temperature of the motor case under 100°C.
- The driver's automatic current cutback function at motor standstill reduces maximum holding torque by approximately 40%.

Standard Type Motor Frame Size 42 mm, 50 mm

Specifications RoHS

Model	Single Shaft	CMK243AP	CMK244AP	CMK245AP	CMK256AP	CMK258AP
	Double Shaft	CMK243BP	CMK244BP	CMK245BP	CMK256BP	CMK258BP
Maximum Holding Torque	N·m	0.16	0.26	0.32	0.56	1.2
Rotor Inertia	J: kg·m ²	35×10 ⁻⁷	54×10 ⁻⁷	68×10 ⁻⁷	230×10 ⁻⁷	420×10 ⁻⁷
Rated Current	A/Phase	0.95		1.2		2
Basic Step Angle		1.8°				
Power Source		24 VDC±10% 1.5 A	24 VDC±10% 1.7 A		24 VDC±10% 2.9 A	
Excitation Mode		Microstep				
Mass	Motor	kg	0.21	0.27	0.35	0.53
	Driver	kg	0.05			
Dimension No.	Motor	[4]			[5]	
	Driver	[10]				

How to read specifications table → Page C-10

Speed – Torque Characteristics How to read speed – torque characteristics → Page C-10

CMK243AP/CMK243BP

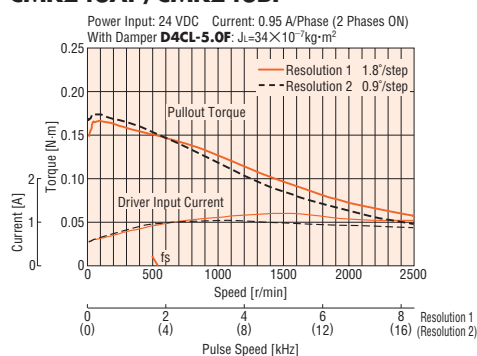

CMK244AP/CMK244BP

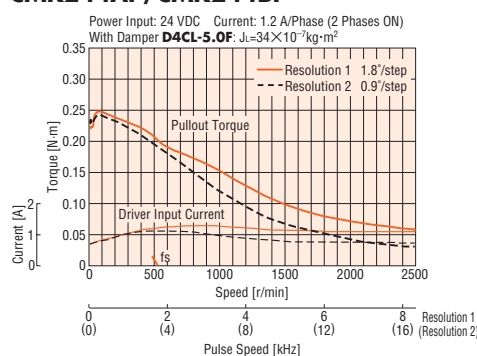

CMK245AP/CMK245BP

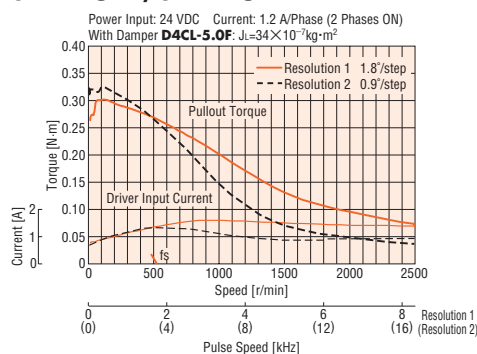

CMK256AP/CMK256BP

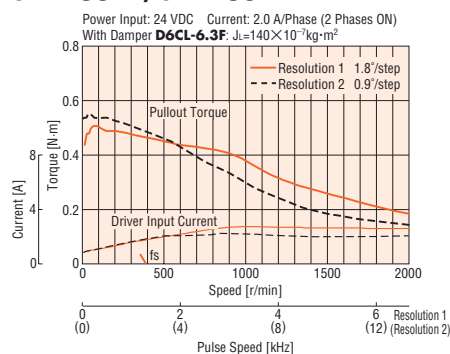

CMK258AP/CMK258BP

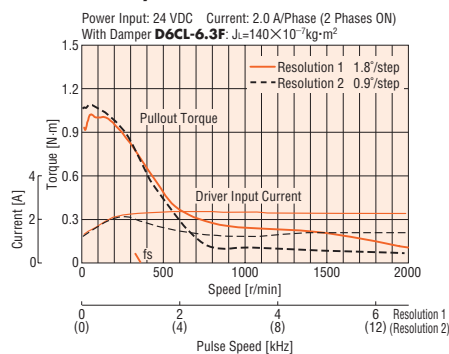

● The pulse input circuit responds to approximately 100 kHz with a pulse duty of 50%.

Notes:

- Pay attention to heat dissipation from motor as there will be a considerable amount of heat under certain conditions. Be sure to keep the temperature of the motor case under 100°C.
- The driver's automatic current cutback function at motor standstill reduces maximum holding torque by approximately 40%.

Standard Type Motor Frame Size 56.4 mm

Specifications RoHS

Model	Single Shaft	CMK264AP	CMK266AP	CMK268AP
	Double Shaft	CMK264BP	CMK266BP	CMK268BP
Maximum Holding Torque	N·m	0.36	0.82	1.35
Rotor Inertia	J: kg·m ²	120×10 ⁻⁷	300×10 ⁻⁷	480×10 ⁻⁷
Rated Current	A/Phase	2		
Basic Step Angle	1.8°			
Power Source	24 VDC±10% 2.9 A			
Excitation Mode	Microstep			
Mass	Motor	kg	0.45	0.7
	Driver	kg	0.05	
Dimension No.	Motor	6		
	Driver	10		

How to read specifications table → Page C-10

Speed – Torque Characteristics How to read speed – torque characteristics → Page C-10

CMK264AP/CMK264BP

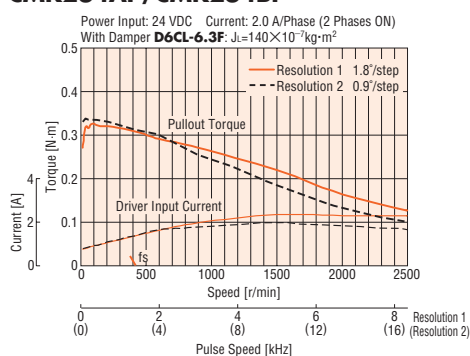

CMK266AP/CMK266BP

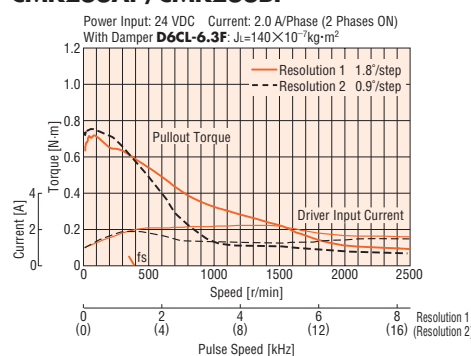

CMK268AP/CMK268BP

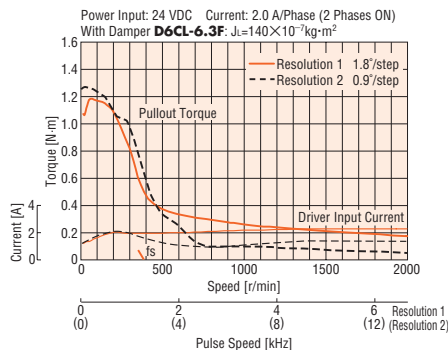

- The pulse input circuit responds to approximately 100 kHz with a pulse duty of 50%.

Notes:

- Pay attention to heat dissipation from motor as there will be a considerable amount of heat under certain conditions. Be sure to keep the temperature of the motor case under 100°C.
- The driver's automatic current cutback function at motor standstill reduces maximum holding torque by approximately 40%.

High-Resolution Type Motor Frame Size 42 mm, 56.4 mm

Specifications RoHS

Model	Single Shaft	CMK243MAP	CMK244MAP	CMK245MAP	CMK264MAP	CMK266MAP	CMK268MAP	
	Double Shaft	CMK243MBP	CMK244MBP	CMK245MBP	CMK264MBP	CMK266MBP	CMK268MBP	
Maximum Holding Torque	N·m	0.16	0.26	0.32	0.37	0.9	1.35	
Rotor Inertia	J: kg·m ²	35×10 ⁻⁷	54×10 ⁻⁷	68×10 ⁻⁷	120×10 ⁻⁷	300×10 ⁻⁷	480×10 ⁻⁷	
Rated Current	A/Phase	0.95	1.2		2			
Basic Step Angle		0.9°						
Power Source		24 VDC±10% 1.5 A		24 VDC±10% 1.7 A		24 VDC±10% 2.9 A		
Excitation Mode		Microstep						
Mass	Motor	kg	0.24	0.3	0.37	0.45	0.7	1
	Driver	kg	0.05					
Dimension No.	Motor	[4]				[6]		
	Driver	[10]						

How to read specifications table → Page C-10

Speed – Torque Characteristics How to read speed – torque characteristics → Page C-10

CMK243MAP/CMK243MBP

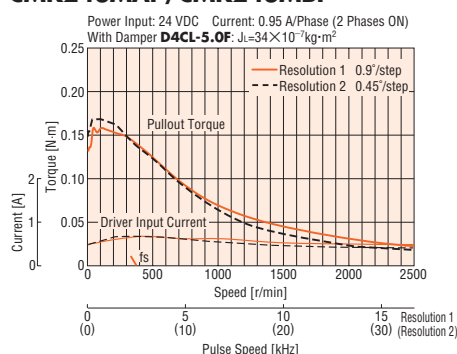

CMK244MAP/CMK244MBP

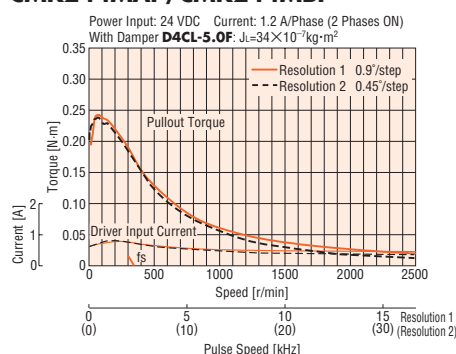

CMK245MAP/CMK245MBP

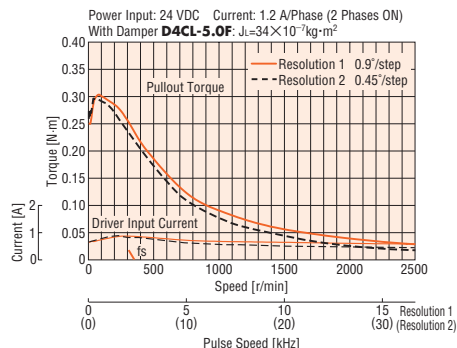

CMK264MAP/CMK264MBP

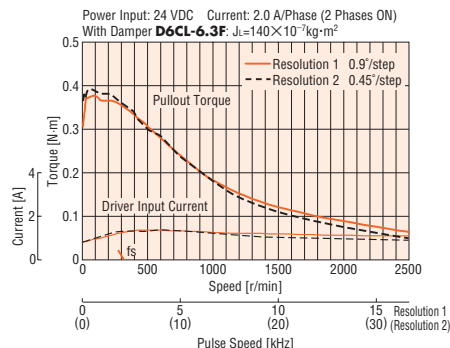

CMK266MAP/CMK266MBP

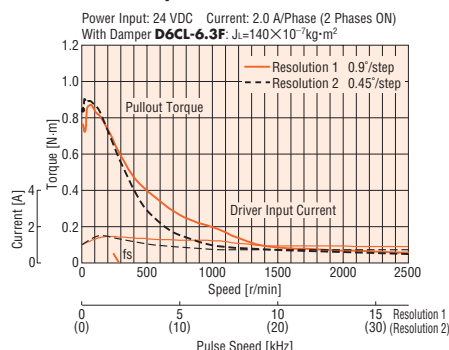

CMK268MAP/CMK268MBP

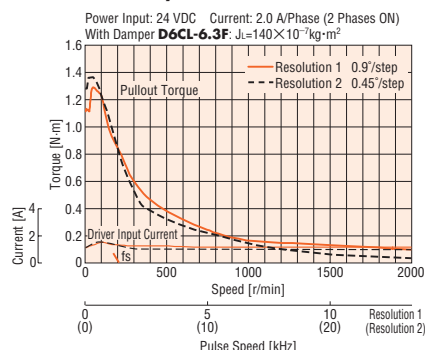

● The pulse input circuit responds to approximately 100 kHz with a pulse duty of 50%.

Notes:

- Pay attention to heat dissipation from motor as there will be a considerable amount of heat under certain conditions. Be sure to keep the temperature of the motor case under 100°C.
- The driver's automatic current cutback function at motor standstill reduces maximum holding torque by approximately 40%.

SH Geared Type Motor Frame Size 28 mm

Specifications RoHS

Model	Single Shaft	CMK223AP-SG7.2*	CMK223AP-SG9*	CMK223AP-SG10*	CMK223AP-SG18*	CMK223AP-SG36*
	Double Shaft	CMK223BP-SG7.2*	CMK223BP-SG9*	CMK223BP-SG10*	CMK223BP-SG18*	CMK223BP-SG36*
Maximum Holding Torque	N·m	0.3			0.4	
Rotor Inertia	J: kg·m ²	9×10 ⁻⁷				
Rated Current	A/Phase	0.95				
Basic Step Angle		0.25°	0.2°	0.18°	0.1°	0.05°
Gear Ratio		1: 7.2	1: 9	1: 10	1: 18	1: 36
Permissible Torque	N·m	0.3			0.4	
Permissible Speed Range	r/min	0~250	0~200	0~180	0~100	0~50
Power Source		24 VDC±10% 1.5 A				
Excitation Mode		Microstep				
Mass	Motor	kg			0.16	
	Driver	kg			0.05	
Dimension No.	Motor				7	
	Driver				10	

How to read specifications table → Page C-10

* Motor lead wire/connector assembly of 0.6 m is included with the motor and driver package of connector coupled type.

● Backlash value is approximately 1 to 2°.

Note:

● Direction of rotation of the motor and that of the gear output shaft are the same for gear ratios 1:7.2 and 1:36. It is the opposite for 1:9, 1:10 and 1:18 gear ratios.

Speed – Torque Characteristics How to read speed – torque characteristics → Page C-10

CMK223AP-SG7.2/CMK223BP-SG7.2

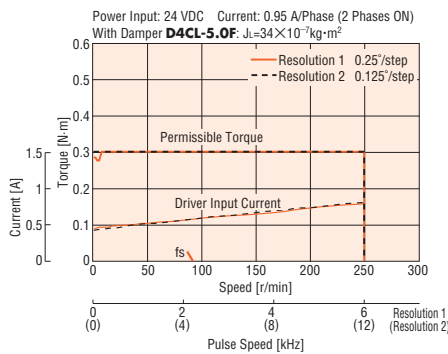

CMK223AP-SG9/CMK223BP-SG9

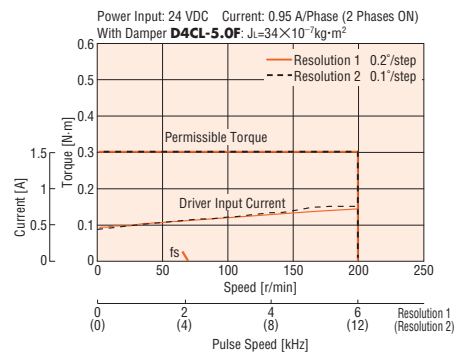

CMK223AP-SG10/CMK223BP-SG10

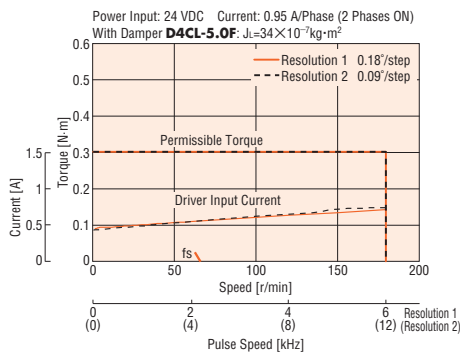

CMK223AP-SG18/CMK223BP-SG18

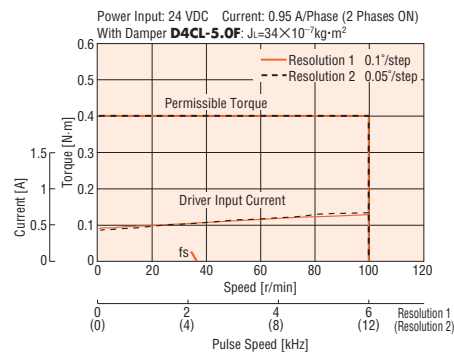

CMK223AP-SG36/CMK223BP-SG36

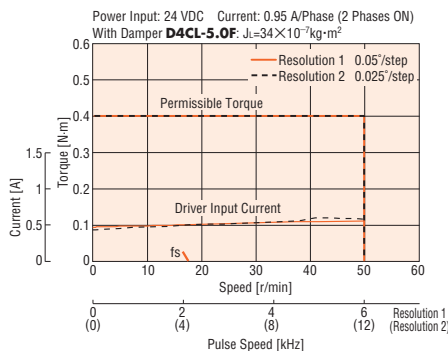

● The pulse input circuit responds to approximately 100 kHz with a pulse duty of 50%.

Notes:

- Pay attention to heat dissipation from motor as there will be a considerable amount of heat under certain conditions. Be sure to keep the temperature of the motor case under 100°C.
- The driver's automatic current cutback function at motor standstill reduces maximum holding torque by approximately 40%.

SH Geared Type Motor Frame Size 42 mm

Specifications RoHS

Model	Single Shaft	CMK243AP-SG3.6	CMK243AP-SG7.2	CMK243AP-SG9	CMK243AP-SG10
	Double Shaft	CMK243BP-SG3.6	CMK243BP-SG7.2	CMK243BP-SG9	CMK243BP-SG10
Maximum Holding Torque	N-m	0.2	0.4	0.5	0.56
Rotor Inertia	J: kg·m ²	35 × 10 ⁻⁷			
Rated Current	A/Phase	0.95			
Basic Step Angle		0.5°	0.25°	0.2°	0.18°
Gear Ratio		1: 3.6	1: 7.2	1: 9	1: 10
Permissible Torque	N-m	0.2	0.4	0.5	0.56
Permissible Speed Range	r/min	0~500	0~250	0~200	0~180
Power Source		24 VDC ± 10% 1.5 A			
Excitation Mode		Microstep			
Mass	Motor	kg		0.35	
	Driver	kg		0.05	
Dimension No.	Motor			[8]	
	Driver			[10]	

Model	Single Shaft	CMK243AP-SG18	CMK243AP-SG36	CMK243AP-SG50	CMK243AP-SG100
	Double Shaft	CMK243BP-SG18	CMK243BP-SG36	CMK243BP-SG50	CMK243BP-SG100
Maximum Holding Torque	N-m	0.8			
Rotor Inertia	J: kg·m ²	35 × 10 ⁻⁷			
Rated Current	A/Phase	0.95			
Basic Step Angle		0.1°	0.05°	0.036°	0.018°
Gear Ratio		1: 18	1: 36	1: 50	1: 100
Permissible Torque	N-m	0.8			
Permissible Speed Range	r/min	0~100	0~50	0~36	0~18
Power Source		24 VDC ± 10% 1.5 A			
Excitation Mode		Microstep			
Mass	Motor	kg		0.35	
	Driver	kg		0.05	
Dimension No.	Motor			[8]	
	Driver			[10]	

How to read specifications table → Page C-10

● Backlash value is approximately 1 to 2°.

Note:

● Direction of rotation of the motor and that of the gear output shaft are the same for gear ratios 1: 3.6, 1: 7.2, 1: 9, 1: 10, 1: 50 and 1: 100. It is the opposite for 1:18 and 1:36 gear ratios.

Speed – Torque Characteristics How to read speed – torque characteristics → Page C-10

CMK243AP-SG3.6/CMK243BP-SG3.6

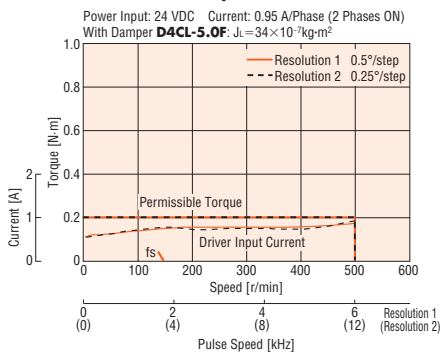

CMK243AP-SG7.2/CMK243BP-SG7.2

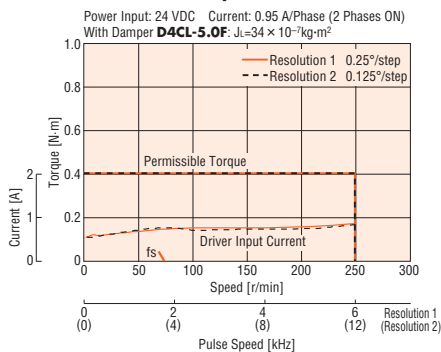

CMK243AP-SG9/CMK243BP-SG9

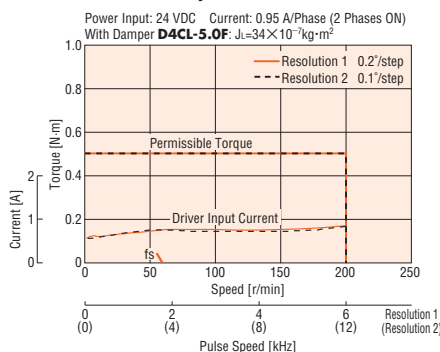

CMK243AP-SG10/CMK243BP-SG10

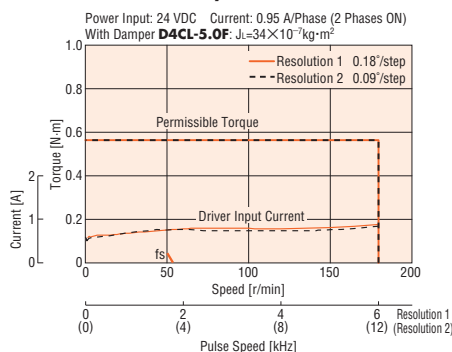

CMK243AP-SG18/CMK243BP-SG18

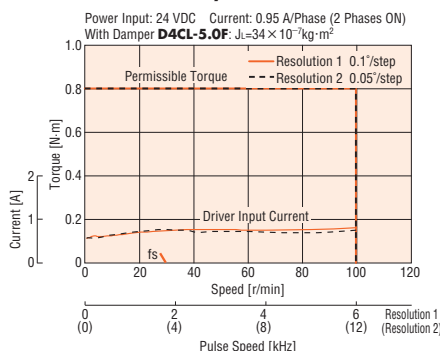

CMK243AP-SG36/CMK243BP-SG36

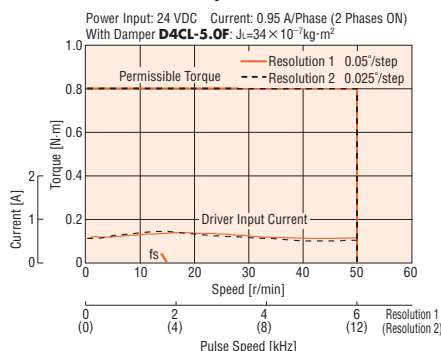

CMK243AP-SG50/CMK243BP-SG50

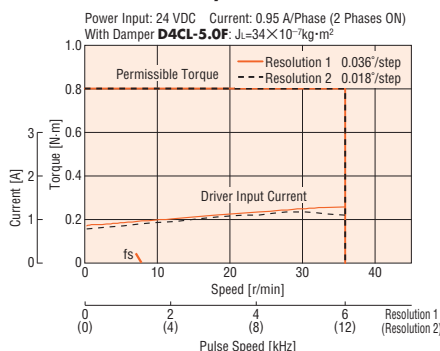

CMK243AP-SG100/CMK243BP-SG100

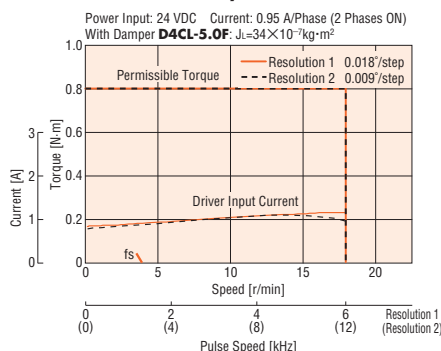

● The pulse input circuit responds to approximately 100 kHz with a pulse duty of 50%.

Notes:

- Pay attention to heat dissipation from motor as there will be a considerable amount of heat under certain conditions. Be sure to keep the temperature of the motor case under 100°C.
- The driver's automatic current cutback function at motor standstill reduces maximum holding torque by approximately 40%.

SH Geared Type Motor Frame Size 60 mm

Specifications RoHS

Model	Single Shaft	CMK264AP-SG3.6	CMK264AP-SG7.2	CMK264AP-SG9	CMK264AP-SG10
	Double Shaft	CMK264BP-SG3.6	CMK264BP-SG7.2	CMK264BP-SG9	CMK264BP-SG10
Maximum Holding Torque	N-m	1	2	2.5	2.7
Rotor Inertia	J: kg·m ²	120×10 ⁻⁷			
Rated Current	A/Phase	2			
Basic Step Angle		0.5°	0.25°	0.2°	0.18°
Gear Ratio		1: 3.6	1: 7.2	1: 9	1: 10
Permissible Torque	N-m	1	2	2.5	2.7
Permissible Speed Range	r/min	0~500	0~250	0~200	0~180
Power Source		24 VDC±10% 2.9 A			
Excitation Mode		Microstep			
Mass	Motor	kg		0.75	
	Driver	kg		0.05	
Dimension No.	Motor	[9]			
	Driver	[10]			

Model	Single Shaft	CMK264AP-SG18	CMK264AP-SG36	CMK264AP-SG50	CMK264AP-SG100
	Double Shaft	CMK264BP-SG18	CMK264BP-SG36	CMK264BP-SG50	CMK264BP-SG100
Maximum Holding Torque	N-m	3	4		
Rotor Inertia	J: kg·m ²	120×10 ⁻⁷			
Rated Current	A/Phase	2			
Basic Step Angle		0.1°	0.05°	0.036°	0.018°
Gear Ratio		1: 18	1: 36	1: 50	1: 100
Permissible Torque	N-m	3	4		
Permissible Speed Range	r/min	0~100	0~50	0~36	0~18
Power Source		24 VDC±10% 2.9 A			
Excitation Mode		Microstep			
Mass	Motor	kg		0.75	
	Driver	kg		0.05	
Dimension No.	Motor	[9]			
	Driver	[10]			

How to read specifications table → Page C-10

● Backlash value is approximately 1 to 2°.

Note:

● Direction of rotation of the motor and that of the gear output shaft are the same for gear ratios 1:3.6, 1:7.2, 1:9, 1:10, 1:50 and 1:100. It is the opposite for 1:18 and 1:36 gear ratios.

Speed – Torque Characteristics How to read speed – torque characteristics → Page C-10

CMK264AP-SG3.6/CMK264BP-SG3.6

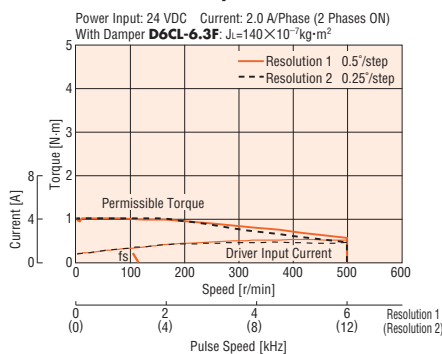

CMK264AP-SG7.2/CMK264BP-SG7.2

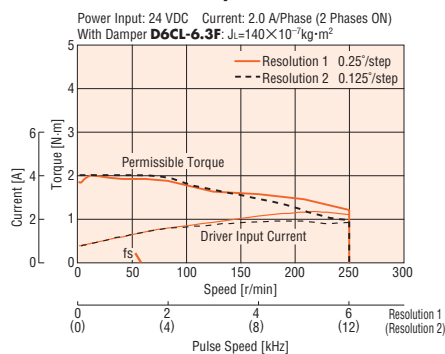

CMK264AP-SG9/CMK264BP-SG9

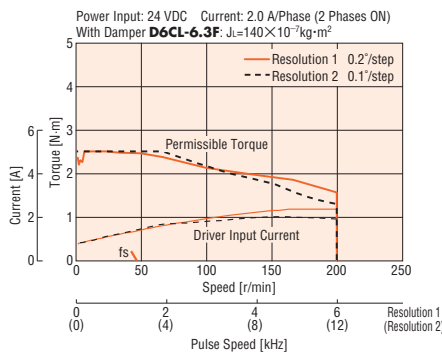

CMK264AP-SG10/CMK264BP-SG10

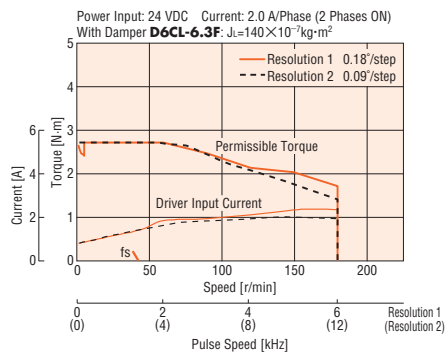

CMK264AP-SG18/CMK264BP-SG18

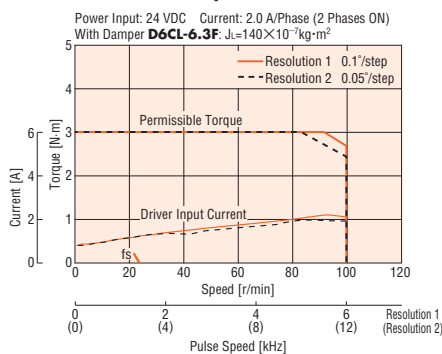

CMK264AP-SG36/CMK264BP-SG36

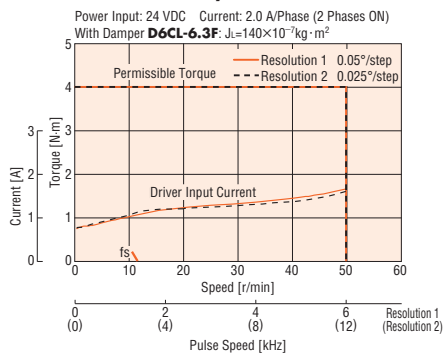

CMK264AP-SG50/CMK264BP-SG50

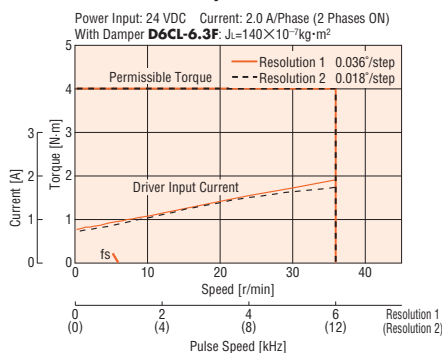

CMK264AP-SG100/CMK264BP-SG100

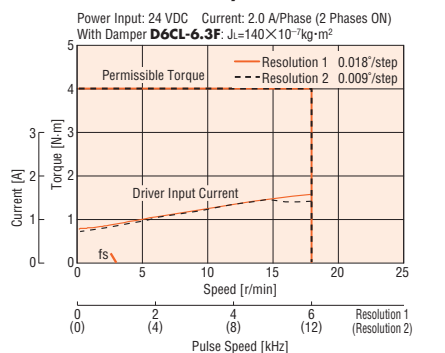

● The pulse input circuit responds to approximately 100 kHz with a pulse duty of 50%.

Notes:

- Pay attention to heat dissipation from motor as there will be a considerable amount of heat under certain conditions. Be sure to keep the temperature of the motor case under 100°C.
- The driver's automatic current cutback function at motor standstill reduces maximum holding torque by approximately 40%.

Driver Specifications

Input Signal	Input Mode	Photocoupler input Pulse (CW pulse) signal/Rotation direction (CCW pulse) signal: Input resistance 200 Ω, Input current 5~20 mA Photocoupler ON: +3~5.25 V Photocoupler OFF: 0~+1 V (Voltage between terminals) All windings off signal/Step angle select signal/Automatic current cutback release signal: Input resistance 3.3 kΩ, Input current 1 mA (5 VDC)/8 mA (24 VDC) Photocoupler ON: +4.5~26.4 V Photocoupler OFF: 0~+1 V (Voltage between terminals)
	Pulse Signal (CW Pulse Signal)	Operation command pulse signal (CW direction operation command pulse signal when in 2-pulse input mode) Negative logic pulse input Pulse width: 5 μs minimum; Pulse rise/fall: 2 μs maximum Pulse duty: 50% and below The motor moves one step when the pulse input is switched from ON to OFF. Maximum input pulse frequency: 100 kHz (When the pulse duty is 50%)
	Rotation Direction Signal (CCW Pulse Signal)	Rotation direction signal Photocoupler ON: CW, Photocoupler OFF: CCW CCW direction operation command pulse signal when in 2-pulse input mode Negative logic pulse input Pulse width: 5 μs minimum; Pulse rise/fall: 2 μs maximum Pulse duty: 50% and below The motor moves one step when the pulse input is switched from ON to OFF. Maximum input pulse frequency: 100 kHz (When the pulse duty is 50%)
	All Windings Off Signal	When in the "photocoupler ON" state, the output current to the motor is cut off and the motor shaft can be rotated manually. When in the "photocoupler OFF" state, the output current to the motor is turned on.
	Step Angle Select Signal	When in the "photocoupler ON" state, the motor operates at the basic step angle regardless of the settings of the step angle setting switches. When in the "photocoupler OFF" state, the motor operates at the step angle set by the step angle setting switches.
	Automatic Current Cutback Release Signal	When in the "photocoupler ON" state, the automatic current cutback function will not be activated even after the motor stops. When in the "photocoupler OFF" state, the automatic current cutback function will be activated after the motor stops (after approx. 100 ms).
Output Mode	Photocoupler, Open-collector output External use condition: 24 VDC maximum, 10 mA maximum	
Output Signal	Excitation Timing Signal	The signal is output every time the excitation sequence returns to the initial stage "0" (Photocoupler: ON). • High-torque type, standard type Example) 1.8°/step (resolution 1): signal output every 4 pulses 0.45°/step (resolution 4): signal output every 16 pulses • High-resolution type Example) 0.9°/step (resolution 1): signal output every 4 pulses 0.225°/step (resolution 4): signal output every 16 pulses • SH geared type (gear ratio 1:18) Example) 0.1°/step (resolution 1): signal output every 4 pulses 0.025°/step (resolution 4): signal output every 16 pulses
	Function	Automatic current cutback, Step angle select, Pulse input mode switch, All windings off, Excitation timing
Cooling Method	Natural ventilation	

General Specifications

Specifications	Motor	Driver
Insulation Class	Class B (130°C)	—
Insulation Resistance	100 MΩ or more when 500 VDC megger is applied between the windings and the case under normal ambient temperature and humidity.	—
Dielectric Strength	Sufficient to withstand 1.0 kV at 50 Hz or 60 Hz applied between the windings and the case for 1 minute under normal ambient temperature and humidity. (0.5 kV for models with frame size 42 mm or smaller)	—
Operating Environment (In Operation)	Ambient Temperature	−10~+50°C (non-freezing)
	Ambient Humidity	85% or less (non-condensing)
	Atmosphere	No corrosive gases, dust, water or oil
Temperature Rise	Temperature rise of windings are 80°C or less measured by the resistance change method (at rated voltage, at standstill, two phases energized)	—
Stop Position Accuracy*1	±3 arc minutes (±0.05°)	—
Shaft Runout	0.05 T.I.R. (mm)*4	—
Radial Play*2	0.025 mm maximum of 5 N	—
Axial Play*3	0.075 mm maximum of 10 N	—
Concentricity	0.075 T.I.R. (mm)*4	—
Perpendicularity	0.075 T.I.R. (mm)*4	—

*1 This value is for full step under no load. (The value changes with the size of the load.)

*2 Radial Play: Displacement in shaft position in the radial direction, when a 5 N load is applied in the vertical direction to the tip of the motor's shaft.

*3 Axial Play: Displacement in shaft position in the axial direction, when a 10 N load is applied to the motor's shaft in the axial direction.

*4 T.I.R. (Total Indicator Reading): The total dial gauge reading when the measurement section is rotated one revolution centered on the reference axis center.

Note:

● Do not measure insulation resistance or perform the dielectric strength test while the motor and driver are connected.

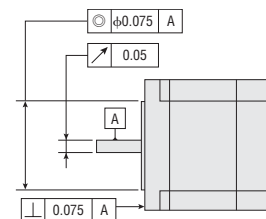

■ Permissible Overhung Load and Permissible Thrust Load

Unit = N

Type	Model	Permissible Overhung Load Distance from Shaft End (mm)					Permissible Thrust Load
		0	5	10	15	20	
High-Torque Type	CMK223P□P CMK224P□P CMK225P□P	25	34	52	—	—	The permissible thrust load shall be no greater than the motor mass.
	CMK233P□P CMK235P□P	20	25	34	52	—	
	CMK244P□P CMK246P□P	20	25	34	52	—	
Standard Type	CMK243□P CMK244□P CMK245□P	20	25	34	52	—	
	CMK256□P CMK258□P	54	67	89	130	—	
	CMK264□P CMK266□P CMK268□P	54	67	89	130	—	
High-Resolution Type	CMK243M□P CMK244M□P CMK245M□P	20	25	34	52	—	
	CMK264M□P CMK266M□P CMK268M□P	54	67	89	130	—	
SH Geared Type	CMK223□P-SG7.2 CMK223□P-SG9 CMK223□P-SG10 CMK223□P-SG18 CMK223□P-SG36	15	17	20	23	—	
	CMK243□P-SG3.6 CMK243□P-SG7.2 CMK243□P-SG9 CMK243□P-SG10 CMK243□P-SG18 CMK243□P-SG36 CMK243□P-SG50 CMK243□P-SG100	10	15	20	30	—	15
	CMK264□P-SG3.6 CMK264□P-SG7.2 CMK264□P-SG9 CMK264□P-SG10	30	40	50	60	70	30
	CMK264□P-SG18 CMK264□P-SG36 CMK264□P-SG50 CMK264□P-SG100	80	100	120	140	160	

● Enter **A** (single shaft) or **B** (double shaft) in the box (□) within the model name.

Introduction

AC Input
Q5STEP
ASDC Input
Q5STEP
ASCAC Input
5-Phase
RK5-Phase
CRKDC Input
2-Phase
CMK2-Phase
CSK2-Phase
Stepping
Motors5-Phase
Stepping
Motors

Controllers

Accessories

Installation

Dimensions (Unit = mm)

● Motor

◇ High-Torque Type

1 □ 28 mm

Model	Motor Model	L1	L2	Mass (kg)
CMK223PAP	PK223PA	32	—	0.11
CMK223PBP	PK223PB		42	
CMK224PAP	PK224PA	40	—	0.14
CMK224PBP	PK224PB		50	
CMK225PAP	PK225PA	51.5	—	0.2
CMK225PBP	PK225PB		61.5	

Motor lead wire/connector assembly (0.6 m) is included with the package. UL Style 3265, AWG24

If you are purchasing only a motor for maintenance purpose, etc., motor lead wire/connector assembly and connector will not be supplied. They must be purchased separately.

→ Page C-255

● Applicable Connector

Connector housing: 51065-0600 (MOLEX)

Contact: 50212-8100 (MOLEX)

Crimp tool: 57176-5000 (MOLEX)

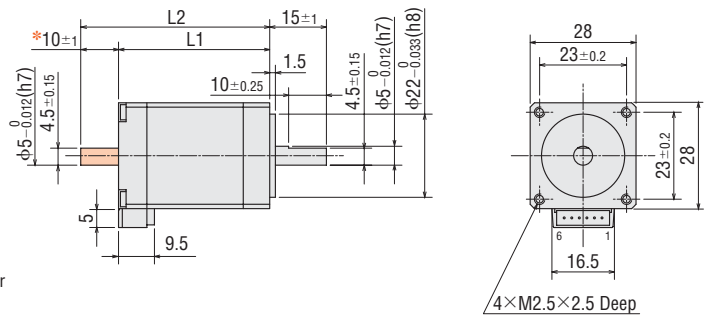

*The length of machining on double shaft model is 10±0.25.

2 □ 35 mm

Model	Motor Model	L1	L2	Mass (kg)
CMK233PAP	PK233PA	37	—	0.18
CMK233PBP	PK233PB		52	
CMK235PAP	PK235PA	52	—	0.285
CMK235PBP	PK235PB		67	

Motor lead wire/connector assembly (0.6 m) is included with the package. UL Style 3265, AWG24

If you are purchasing only a motor for maintenance purpose, etc., motor lead wire/connector assembly and connector will not be supplied. They must be purchased separately.

→ Page C-255

● Applicable Connector

Connector housing: 51103-0600 (MOLEX)

Contact: 50351-8100 (MOLEX)

Crimp tool: 57295-5000 (MOLEX)

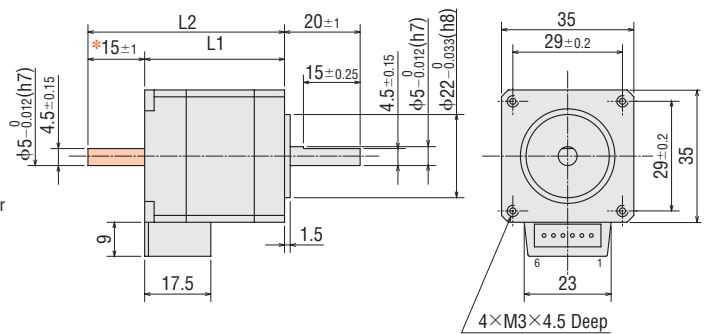

*The length of machining on double shaft model is 15±0.25.

3 □ 42 mm

Model	Motor Model	L1	L2	Mass (kg)
CMK244PAP	PK244PA	39	—	0.3
CMK244PBP	PK244PB		54	
CMK246PAP	PK246PA	59	—	0.5
CMK246PBP	PK246PB		74	

Motor lead wire/connector assembly (0.6 m) is included with the package. UL Style 3265, AWG24

If you are purchasing only a motor for maintenance purpose, etc., motor lead wire/connector assembly and connector will not be supplied. They must be purchased separately.

→ Page C-255

● Applicable Connector

Connector housing: 51103-0600 (MOLEX)

Contact: 50351-8100 (MOLEX)

Crimp tool: 57295-5000 (MOLEX)

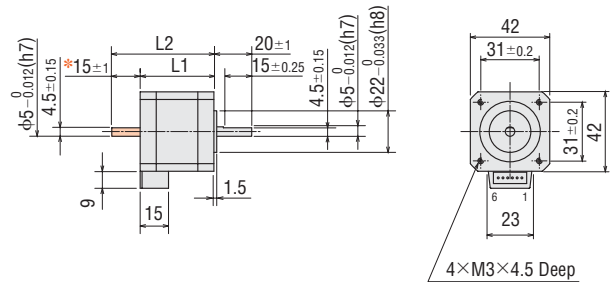

*The length of machining on double shaft model is 15±0.25.

● These dimensions are for double shaft models. For single shaft models, ignore the orange (■) areas.

◇ Standard Type, High-Resolution Type

④ □42 mm

Model	Motor Model	L1	L2	Mass (kg)
CMK243AP	PK243-01A	33	—	0.21
CMK243MAP	PK243MA		—	0.24
CMK243BP	PK243-01B	48	—	0.21
CMK243MBP	PK243MB		—	0.24
CMK244AP	PK244-01A	39	—	0.27
CMK244MAP	PK244MA		—	0.3
CMK244BP	PK244-01B	54	—	0.27
CMK244MBP	PK244MB		—	0.3
CMK245AP	PK245-01A	47	—	0.35
CMK245MAP	PK245MA		—	0.37
CMK245BP	PK245-01B	62	—	0.35
CMK245MBP	PK245MB		—	0.37

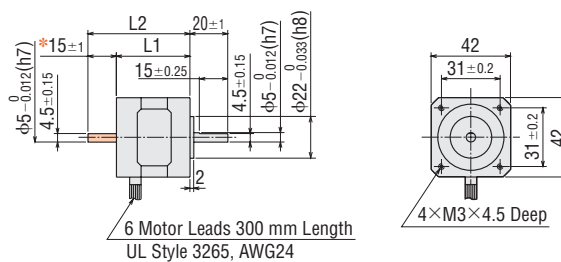

*The length of machining on double shaft model is 15 ± 0.25 .

◇ Standard Type

⑤ □50 mm

Model	Motor Model	L1	L2	Mass (kg)
CMK256AP	PK256-02A	51.5	—	0.53
CMK256BP	PK256-02B		67.5	
CMK258AP	PK258-02A	81	—	0.89
CMK258BP	PK258-02B		97	

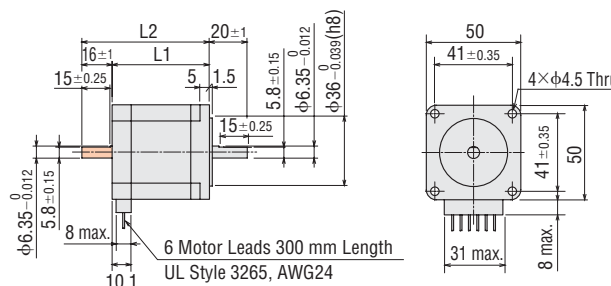

◇ Standard Type, High-Resolution Type

⑥ □56.4 mm

Model	Motor Model	L1	L2	Mass (kg)
CMK264AP	PK264-02A	39	—	0.45
CMK264MAP	PK264MA		—	
CMK264BP	PK264-02B	54	55	0.7
CMK264MBP	PK264MB		—	
CMK266AP	PK266-02A	54	—	0.7
CMK266MAP	PK266MA		—	
CMK266BP	PK266-02B	76	70	1.0
CMK266MBP	PK266MB		—	
CMK268AP	PK268-02A	76	—	1.0
CMK268MAP	PK268MA		—	
CMK268BP	PK268-02B	92	—	1.0
CMK268MBP	PK268MB		—	

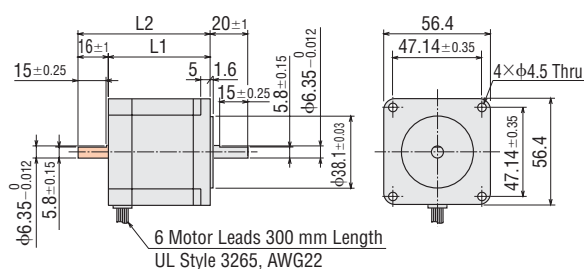

● These dimensions are for double shaft models. For single shaft models, ignore the orange (■) areas.

◇ SH Geared Type

7 □ 28 mm

Model	Motor Model	Gear Ratio	Mass (kg)
CMK223AP-SG □	PK223PA-SG □	7.2, 9, 10, 18, 36	0.16
CMK223BP-SG □	PK223PB-SG □		

● Enter the gear ratio in the box (□) within the model name.

Motor lead wire/connector assembly (0.6 m) is included with the package. UL Style 3265, AWG24

If you are purchasing only a motor for maintenance purpose, etc., motor lead wire/connector assembly and connector will not be supplied. They must be purchased separately.

→ Page C-255

● Screws (Included)

M2.5 Length 8 mm ... 4 Pieces

● Applicable Connector

Connector housing: 51065-0600 (MOLEX)

Contact: 50212-8100 (MOLEX)

Crimp tool: 57176-5000 (MOLEX)

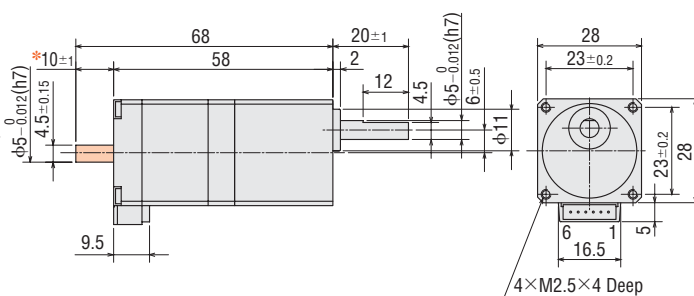

*The length of machining on double shaft model is 10±0.25.

8 □ 42 mm

Model	Motor Model	Gear Ratio	Mass (kg)
CMK243AP-SG □	PK243A1-SG □	3.6, 7.2, 9, 10, 18, 36, 50, 100	0.35
CMK243BP-SG □	PK243B1-SG □		

● Enter the gear ratio in the box (□) within the model name.

● Screws (Included)

M3 Length 10 mm ... 4 Pieces

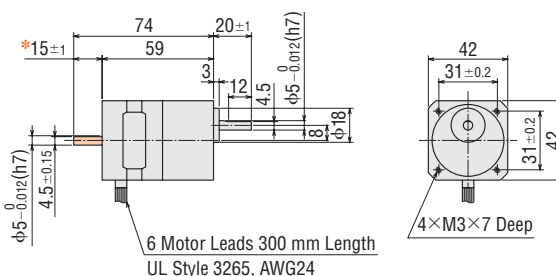

*The length of machining on double shaft model is 15±0.25.

9 □ 60 mm

Model	Motor Model	Gear Ratio	Mass (kg)
CMK264AP-SG □	PK264A2-SG □	3.6, 7.2, 9, 10, 18, 36, 50, 100	0.75
CMK264BP-SG □	PK264B2-SG □		

● Enter the gear ratio in the box (□) within the model name.

● Screws (Included)

M4 Length 15 mm ... 4 Pieces

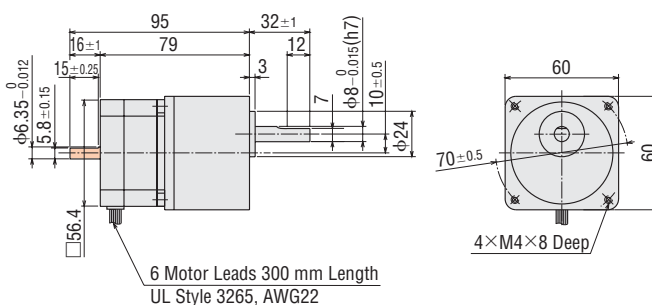

● These dimensions are for double shaft models. For single shaft models, ignore the orange (■) areas.

● Driver

Driver Model: CMD2109P, CMD2112P, CMD2120P

Mass: 0.05 kg

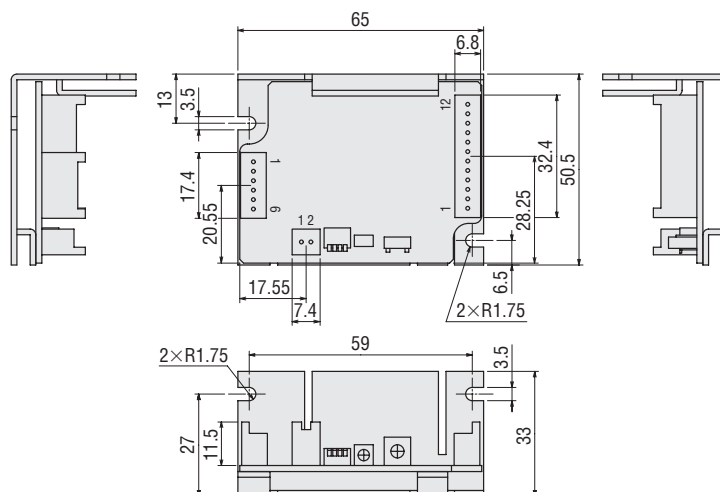

- Connector Housing (Included)
 - 51103-0200 (MOLEX)
 - 51103-1200 (MOLEX)
 - 51103-0600 (MOLEX)
- Contact (Included)
 - 50351-8100 (MOLEX)

Note:

- Use the included connector for power supply, signal and motor. When assembling the connectors, use the hand-operated crimp tool [57295-5000 (MOLEX)]. The crimp tool is not included with the package. It must be purchased separately.

Driver lead wire set crimped with connector (sold separately) is available. → Page C-257

Introduction

AC Input
Q5STEP
ASDC Input
Q5STEP
ASCAC Input
5-Phase
RK5-Phase
CRKDC Input
2-Phase
CMK2-Phase
CSK2-Phase
Stepping
Motors5-Phase
Stepping
Motors

Controllers

Accessories

Installation

Connection and Operation

Names and Functions of Driver Parts

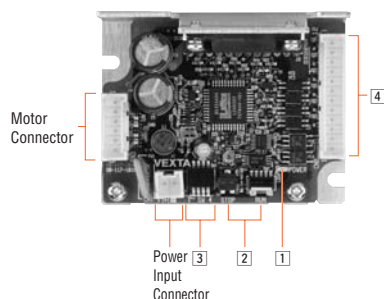

1 Power Input Display

Color	Function	When Activated
Green	Power supply indication	Lights when power is on.

2 Current Adjustment Switch

Indication	Switch Name	Function
RUN	Motor run current switch	For adjusting the motor running current
STOP	Motor stop current potentiometer	For adjusting the current at motor standstill

3 Function Select Switch

Indication	Switch Name	Function
1	Pulse input mode switch	Switches between 1-pulse input and 2-pulse input.
2, 3, 4	Step angle setting switch	These switches can be set to the desired resolution from the five resolution levels.

Step Angle Setting Switch

SW-2	SW-3	SW-4	Microstep/Step	Resolution	Step Angle
OFF	OFF	OFF	1	200	1.8°
OFF	OFF	ON	2	400	0.9°
OFF	ON	OFF	4	800	0.45°
OFF	ON	ON	8	1600	0.225°
ON	OFF	OFF	16	3200	0.1125°

Notes:

- Use of any setting other than the combinations listed in the table will automatically set the microstep to "1" and the motor will operate at the basic step angle.
- The step angle is calculated by dividing the basic step angle by the number of microstep. The above figures are based on a basic step angle of 1.8°.
- With the high-resolution type, the basic step angle and resolution are 0.9°, 400 (microstep/step: 1).
- The step angle set with the step angle setting switches will become effective when the "Step Angle Select" (CS) signal input is OFF.
- Do not change the CS (step angle select) signal input or step angle setting switch while the motor is operating. It may cause the motor to misstep and stop. Change the step angle setting switches, when the "Step Angle Select" signal input is OFF and the "Excitation Timing" signal output is ON.

4 Input/Output Signal

Indication	Input/Output	Pin No.	Signal Name	Function
CN2	Input signal	1	Pulse signal (CW pulse signal)	Operation command pulse signal (The motor will rotate in the CW direction when in 2-pulse input mode.)
		2		
		3	Rotation direction signal (CCW pulse signal)	Rotation direction signal Photocoupler OFF: CCW, Photocoupler ON: CW (The motor will rotate in the CCW direction when in 2-pulse input mode.)
		4		
		5	All windings off signal	Cuts the output current to the motor and allows the motor shafts to be rotated by external force.
		6		
		7	Step angle select signal	The motor will operate at the basic step angle regardless of the settings of the step angle setting switches.
		8		
		9	Automatic current cutback release signal	This signal is used to disable the automatic current cutback function.
		10		
Output signal		11	Excitation timing signal	Outputs signals when the excitation sequence is at STEP "0."
		12		

● Connection Diagrams

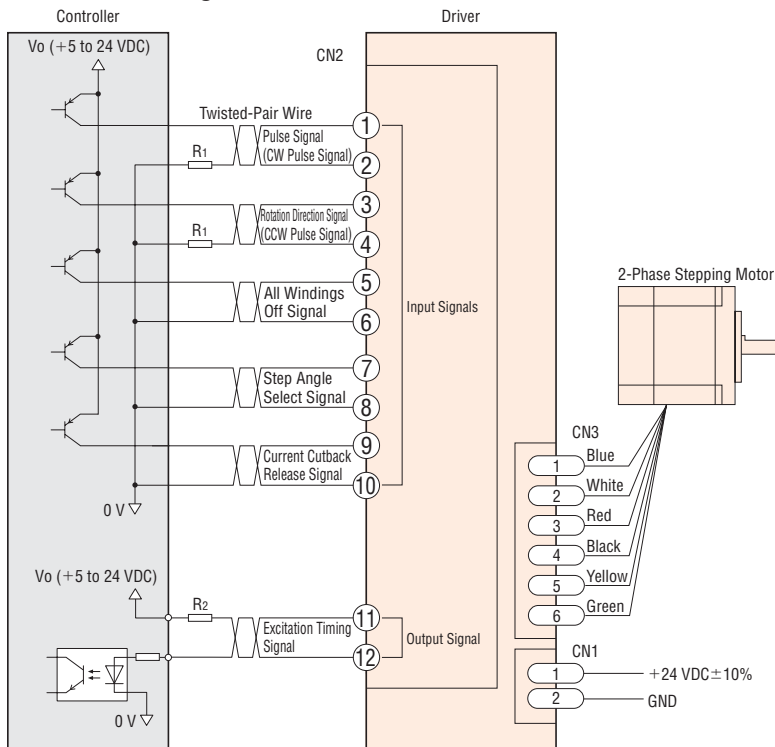

◇ Input Signal Connection

● Pulse (CW) Signal/Rotation Direction (CCW) Signal
 Signals can be connected directly when 5 VDC is supplied. When the voltage exceeds 5 VDC, connect the external resistor to keep input current at 20 mA or less.
 When 5 VDC or more is applied without the external resistor, the internal components get damaged.
 Example: If the voltage is 24 VDC, connect a resistor (R₁) of 1.5 to 2.2 kΩ and 0.5 W or more.
 ● All Windings Off Signal/Step Angle Select Signal/Automatic Current Cutback Release Signal
 Signals can be connected directly when 5 to 24 VDC is supplied.

◇ Output Signal Connection

Use the output signal at 24 VDC or less and 10 mA or less. If these specifications are exceeded, the internal components may get damaged. Check the specification of the connected equipment. If the current exceeds 10 mA, connect the external resistor R₂.

◇ Power Supply

Use a power supply that can supply sufficient input current. When power supply capacity is insufficient, a decrease in motor output can cause the following malfunctions:

- Motor does not rotate properly at high-speed.
- Slow motor startup and stopping

◇ Notes on Wiring

- Use twisted-pair wires of AWG24 to 22 (0.2 to 0.3 mm²) and 2 m or less in length for the signal lines.
- Note that as the length of the pulse signal line increases, the maximum transmission frequency decreases. **Technical reference** → Page F-46
- Use wires of AWG22 (0.3 mm²) for power supply lines. When assembling the connectors, use the hand-operated crimp tool or driver lead wire set crimped with connector (sold separately). The crimp tool is not included with the package. It must be purchased separately.
- Signal lines should be kept at least 2 cm away from power lines (power supply lines and motor lines). Do not run the signal lines in the same duct as power lines or bundle them together.
- If noise generated by the motor cable or power supply cable causes a problem, try shielding the cables or insert ferrite cores.
- Incorrect connection of DC power input will lead to driver (circuit) damage. Make sure that the polarity is correct before turning power on.

● Description of Input/Output Signals

Indication of Input/Output Signal "ON"/"OFF"

Input (Output) "ON" indicates that the current is sent into the photocoupler (transistor) inside the driver. Input (Output) "OFF" indicates that the current is not sent into the photocoupler (transistor) inside the driver. The input/output remains "OFF" if nothing is connected.

Photocoupler OFF ON

Pulse (CW) and Rotation Direction (CCW) Input Signal

◇ Input Circuit and Sample Connection

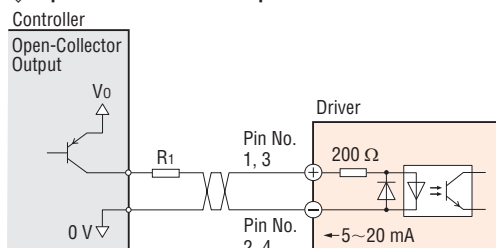

◇ Pulse Waveform Characteristics

● 1-Pulse Input Mode

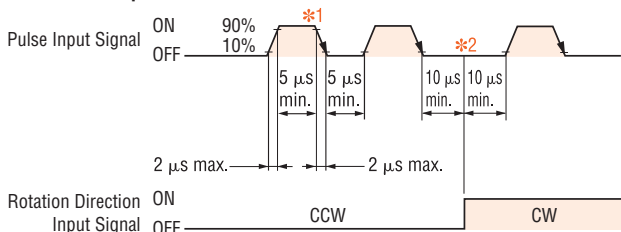

● 2-Pulse Input Mode

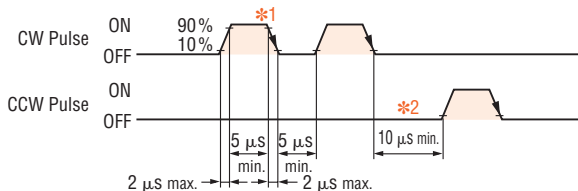

- *1 The shaded area indicates when the photocoupler diode is ON. The motor moves when the photocoupler state changes from ON to OFF.
- *2 The minimum interval time when changing rotation direction 10 μs is shown as a response time of circuit. This value varies greatly depending on the motor type and load inertia.

◇ Pulse Signal Characteristics

- Keep the "Pulse" signal at the "photocoupler OFF" state when no pulses are being input.
- In 1-pulse input mode, leave the "Pulse" signal at rest ("OFF") when changing rotation directions.
- In 2-pulse input mode, do not input a CW pulse and CCW pulse simultaneously.

All Windings Off (AWO)/Step Angle Select (CS)/Automatic Current Cutback Release (ACDOFF) Input Signal

◇ Input Circuit and Sample Connection

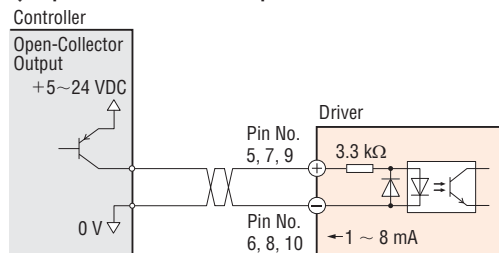

◇ All Windings Off (AWO) Input Signal

- Inputting this signal puts the motor in a non-excitation (free) state.
- This signal is used when moving the motor by external force or perform positioning manually. The photocoupler must be "OFF" when operating the motor.

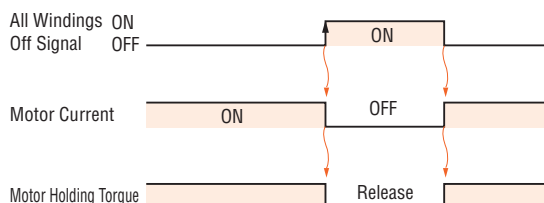

The shaded area indicates that the motor provides holding torque in proportion to standstill current set by STOP switch.

- Switching the "All Windings Off" signal from "photocoupler ON" to "photocoupler OFF" does not alter the excitation sequence. When the motor shaft is manually adjusted with the "All Windings Off" signal input, the shaft will shift up to $\pm 3.6^\circ$ (geared type: $\pm 3.6^\circ/\text{gear ratio}$) from the position set after the "All Windings Off" signal is released.

◇ Step Angle Select (CS) Input Signal

- When this signal input is "ON," the motor will operate at the basic step angle regardless of the settings of the step angle setting switches. When the signal input is "OFF," the motor will operate at the step angle set with the step angle setting switches.
- To change the step angle, do so when the "Excitation Timing" signal output is "ON" and the motor is at standstill.

◇ Automatic Current Cutback Release (ACDOFF) Input Signal

- When this signal is in the "photocoupler ON" state, the automatic current cutback function is disabled. When this signal is in the "photocoupler OFF" state, the automatic current cutback function will be activated after the motor stops (after approx. 100 ms).
- The photocoupler must be "OFF" when the motor is operating.

Excitation Timing (TIM) Output Signal

◇ Output Circuit and Sample Connection

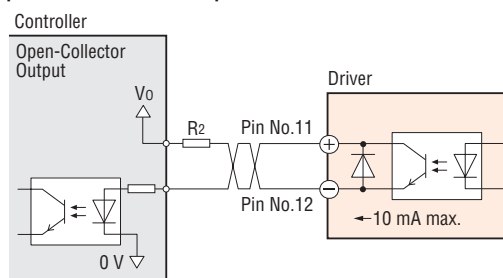

- The "Excitation Timing" signal is output to indicate when the motor excitation is in the initial stage (step "0" at power up).
- The "Excitation Timing" signal is output simultaneously with a pulse input each time the excitation sequence returns to step "0." The excitation sequence will complete one cycle for every 7.2° (3.6° for high-resolution type) rotation of the motor output shaft.
Microstep/step 1: Signal is output once every 4 pulses.
Microstep/step 4: Signal is output once every 16 pulses.

Timing chart at 1.8°/step (microstep/step 1)

* When connected as shown in the sample connection, the signal will be "photocoupler ON" at step "0."

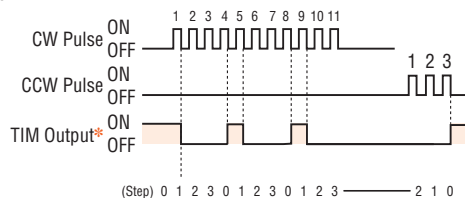

Notes:

- When power is turned on, the excitation sequence is reset to step "0" and the "Excitation Timing" signal will be output.
- When operating the motor using the "Excitation Timing" signal output, make sure the motor output shaft stops at an integral multiple of 7.2° (3.6° for high-resolution type).

Timing Chart

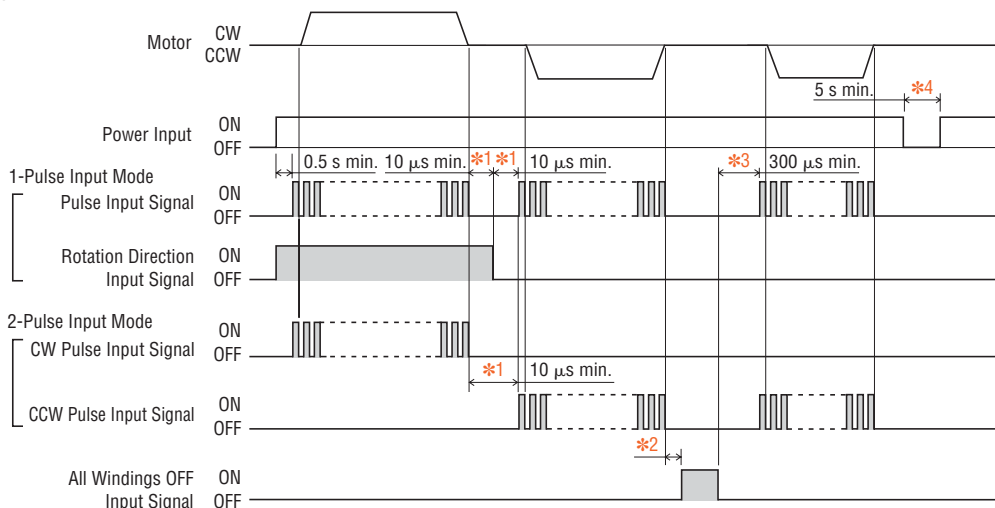

The section indicates that the photocoupler diode is emitting light.

- *1 The minimum switching time to change rotation direction (1-pulse input mode), and switching time to change CW, CCW pulse (2-pulse input mode) 10 μ s is shown as a response time of circuit. The motor may need more time.
- *2 Depends on load inertia, load torque and starting frequency.
- *3 Never input a pulse signal immediately after switching the "All Windings Off" signal to "photocoupler OFF." The motor may not start.
- *4 Wait at least five seconds before turning on the power again.

List of Motor and Driver Combinations

Model names for motor and driver combinations are shown below.

Type	Model	Motor Model	Driver Model
High-Torque Type	CMK223PAP	PK223PA*	CMD2109P
	CMK223PBP	PK223PB*	
	CMK224PAP	PK224PA*	
	CMK224PBP	PK224PB*	
	CMK225PAP	PK225PA*	
	CMK225PBP	PK225PB*	
	CMK233PAP	PK233PA*	CMD2112P
	CMK233PBP	PK233PB*	
	CMK235PAP	PK235PA*	
	CMK235PBP	PK235PB*	
	CMK244PAP	PK244PA*	
	CMK244PBP	PK244PB*	
	CMK246PAP	PK246PA*	
	CMK246PBP	PK246PB*	
Standard Type	CMK243AP	PK243-01A	CMD2109P
	CMK243BP	PK243-01B	
	CMK244AP	PK244-01A	CMD2112P
	CMK244BP	PK244-01B	
	CMK245AP	PK245-01A	
	CMK245BP	PK245-01B	
	CMK256AP	PK256-02A	CMD2120P
	CMK256BP	PK256-02B	
	CMK258AP	PK258-02A	
	CMK258BP	PK258-02B	
CMK264AP	PK264-02A		
CMK264BP	PK264-02B		
CMK266AP	PK266-02A		
CMK266BP	PK266-02B		
CMK268AP	PK268-02A		
CMK268BP	PK268-02B		
High-Resolution Type	CMK243MAP	PK243MA	CMD2109P
	CMK243MBP	PK243MB	
	CMK244MAP	PK244MA	CMD2112P
	CMK244MBP	PK244MB	
	CMK245MAP	PK245MA	
	CMK245MBP	PK245MB	
	CMK264MAP	PK264MA	CMD2120P
	CMK264MBP	PK264MB	
	CMK266MAP	PK266MA	
	CMK266MBP	PK266MB	
	CMK268MAP	PK268MA	
	CMK268MBP	PK268MB	

Type	Model	Motor Model	Driver Model	
SH Geared Type	CMK223AP-SG7.2	PK223PA-SG7.2*	CMD2109P	
	CMK223BP-SG7.2	PK223PB-SG7.2*		
	CMK223AP-SG9	PK223PA-SG9*		
	CMK223BP-SG9	PK223PB-SG9*		
	CMK223AP-SG10	PK223PA-SG10*		
	CMK223BP-SG10	PK223PB-SG10*		
	CMK223AP-SG18	PK223PA-SG18*		
	CMK223BP-SG18	PK223PB-SG18*		
	CMK223AP-SG36	PK223PA-SG36*		
	CMK223BP-SG36	PK223PB-SG36*		
	CMK243AP-SG3.6	PK243A1-SG3.6		
	CMK243BP-SG3.6	PK243B1-SG3.6		
	CMK243AP-SG7.2	PK243A1-SG7.2		
	CMK243BP-SG7.2	PK243B1-SG7.2		
	CMK243AP-SG9	PK243A1-SG9		
	CMK243BP-SG9	PK243B1-SG9		
	CMK243AP-SG10	PK243A1-SG10		
	CMK243BP-SG10	PK243B1-SG10		
	CMK243AP-SG18	PK243A1-SG18		
	CMK243BP-SG18	PK243B1-SG18		
	CMK243AP-SG36	PK243A1-SG36		
	CMK243BP-SG36	PK243B1-SG36		
	CMK243AP-SG50	PK243A1-SG50		
	CMK243BP-SG50	PK243B1-SG50		
	CMK243AP-SG100	PK243A1-SG100		
	CMK243BP-SG100	PK243B1-SG100		
	CMK264AP-SG3.6	PK264A2-SG3.6		CMD2120P
	CMK264BP-SG3.6	PK264B2-SG3.6		
	CMK264AP-SG7.2	PK264A2-SG7.2		
	CMK264BP-SG7.2	PK264B2-SG7.2		
	CMK264AP-SG9	PK264A2-SG9		
	CMK264BP-SG9	PK264B2-SG9		
CMK264AP-SG10	PK264A2-SG10			
CMK264BP-SG10	PK264B2-SG10			
CMK264AP-SG18	PK264A2-SG18			
CMK264BP-SG18	PK264B2-SG18			
CMK264AP-SG36	PK264A2-SG36			
CMK264BP-SG36	PK264B2-SG36			
CMK264AP-SG50	PK264A2-SG50			
CMK264BP-SG50	PK264B2-SG50			
CMK264AP-SG100	PK264A2-SG100			
CMK264BP-SG100	PK264B2-SG100			

* If you are purchasing only a motor for maintenance purpose, etc., motor lead wire/connector assembly and connector will not be supplied. They must be purchased separately. Accessory motor lead wire/connector assembly and motor connector set are available.

→ Page C-255