



DATASHEET

HEX-E/H QC

v1.1

1. Datasheet

1.1. HEX-E QC

General Properties	6-Axis Force/Torque Sensor				Unit
	Fxy	Fz	Txy	Tz	
Nominal Capacity (N.C)	200	200	10	6.5	[N] [Nm]
Single axis deformation at N.C (typical)	± 1.7 ± 0.067	± 0.3 ± 0.011	± 2.5 ± 2.5	± 5 ± 5	[mm] [°] [inch] [°]
Single axis overload	500	500	500	500	[%]
Signal noise* (typical)	0.035	0.15	0.002	0.001	[N] [Nm]
Noise-free resolution (typical)	0.2	0.8	0.01	0.002	[N] [Nm]
Full scale nonlinearity	< 2	< 2	< 2	< 2	[%]
Hysteresis (measured on Fz axis , typical)	< 2	< 2	< 2	< 2	[%]
Crosstalk (typical)	< 5	< 5	< 5	< 5	[%]
IP Classification	67				
Dimensions (H x W x L)	50 x 71 x 93 1.97 x 2.79 x 3.66				[mm] [inch]
Weight (with built-in adapter plates)	0.347 0.76				[kg] [lb]

* Signal noise is defined as the standard deviation (1 σ) of a typical one second no-load signal.

Operating Conditions	Minimum	Typical	Maximum	Unit
Power supply	7	-	24	[V]
Power consumption	-	-	0.8	[W]
Operating temperature	0 32	- -	55 131	[°C] [°F]
Relative humidity (non-condensing)	0	-	95	[%]
Calculated MTBF (operating life)	30 000	-	-	[Hours]
Re-calibration period*	-	15 000	-	[Hours]

*Notification is provided when factory re-calibration is recommended.

Complex Loading

During single-axis loading, the sensor can be operated up to its nominal capacity. Above the nominal capacity the reading is inaccurate and invalid.

During complex loading (when more than one axis is loaded) the nominal capacities are reduced. The following diagrams show the complex loading scenarios.

The sensor cannot be operated outside of the Normal Operating Area (marked with blue on the diagrams below).

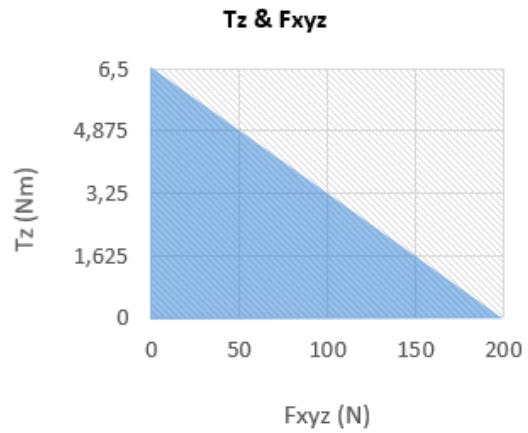
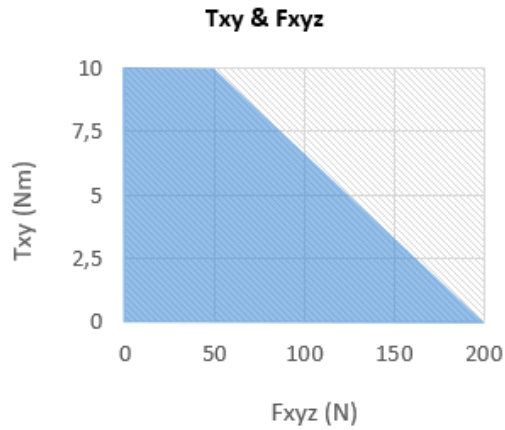

1.2. HEX-H QC

General Properties	6-Axis Force/Torque Sensor				Unit
	Fxy	Fz	Txy	Tz	
Nominal Capacity (N.C)	200	200	20	13	[N] [Nm]
Single axis deformation at N.C (typical)	± 0.6 ± 0.023	± 0.25 ± 0.009	± 2 ± 2	± 3.5 ± 3.5	[mm] [°] [inch] [°]
Single axis overload	500	400	300	300	[%]
Signal noise* (typical)	0.1	0.2	0.006	0.002	[N] [Nm]
Noise-free resolution (typical)	0.5	1	0.036	0.008	[N] [Nm]
Full scale nonlinearity	< 2	< 2	< 2	< 2	[%]
Hysteresis (measured on Fz axis , typical)	< 2	< 2	< 2	< 2	[%]
Crosstalk (typical)	< 5	< 5	< 5	< 5	[%]
IP Classification	67				
Dimensions (H x W x L)	50 x 71 x 93 1.97 x 2.79 x 3.66				[mm] [inch]
Weight (with built-in adapter plates)	0.35 0.77				[kg] [lb]

* Signal noise is defined as the standard deviation (1 σ) of a typical one second no-load signal.

Operating Conditions	Minimum	Typical	Maximum	Unit
Power supply	7	-	24	[V]
Power consumption	-	-	0.8	[W]
Operating temperature	0 32	- -	55 131	[°C] [°F]
Relative humidity (non-condensing)	0	-	95	[%]
Calculated MTBF (operating life)	30 000	-	-	[Hours]

Operating Conditions	Minimum	Typical	Maximum	Unit
Re-calibration period*	-	7 500	-	[Hours]

*Notification is provided when factory re-calibration is recommended.

Complex Loading

During single-axis loading, the sensor can be operated up to its nominal capacity. Above the nominal capacity the reading is inaccurate and invalid.

During complex loading (when more than one axis is loaded) the nominal capacities are reduced. The following diagrams show the complex loading scenarios.

The sensor cannot be operated outside of the Normal Operating Area (marked with blue on the diagrams below).

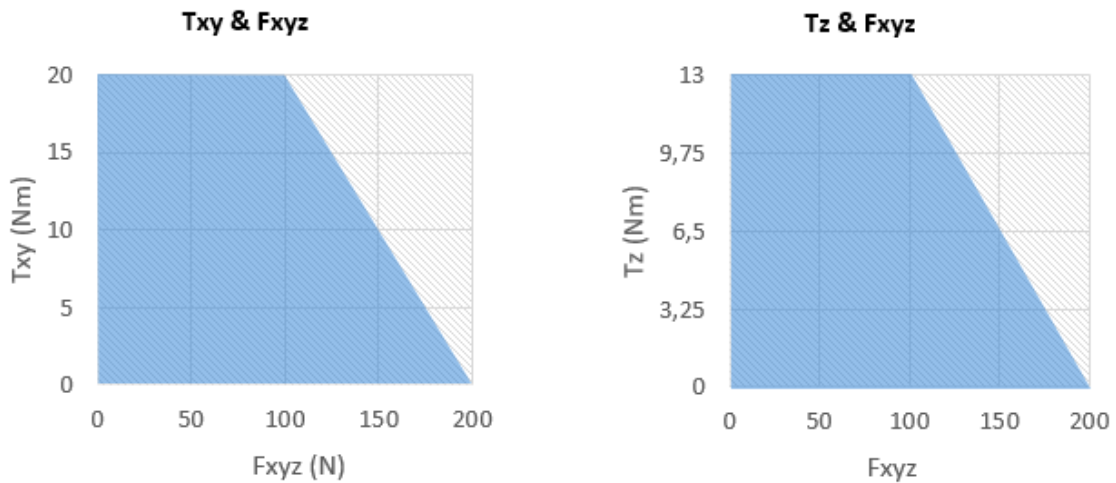

1.3. HEX-E QC and HEX-H QC Comparison

When the sensor is used in applications where higher sensitivity is needed HEX-E QC is recommended, where higher payload or tool length is needed HEX-H QC is recommended.

The following graphs show the extent of the payload and the tool length that you can use together with the HEX-E and the HEX-H sensors in case of applications requiring high or moderate precision.

Applications requiring high precision (e.g.: force control based applications like Sanding and Pin Insertion)

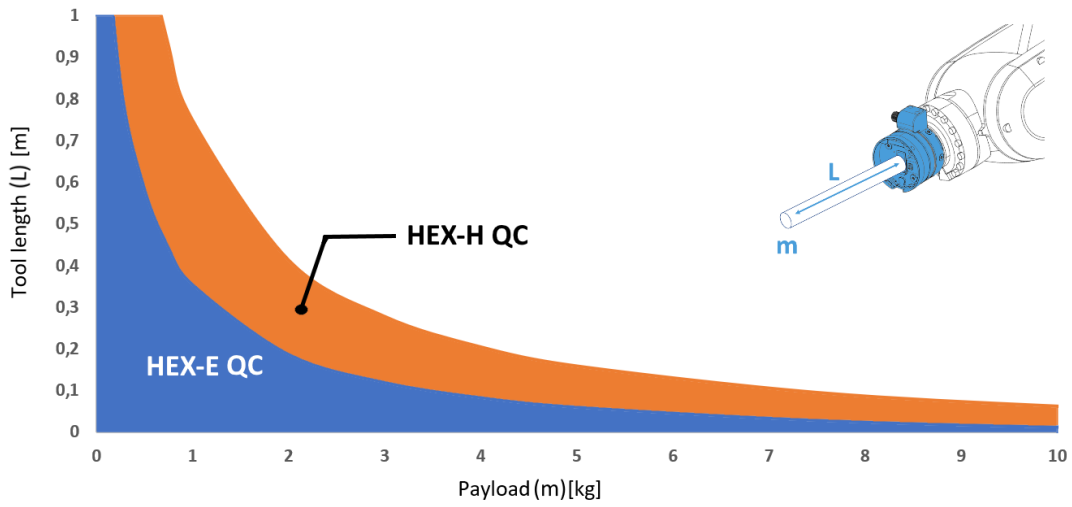

Other applications (e.g.: part detection, force monitoring)

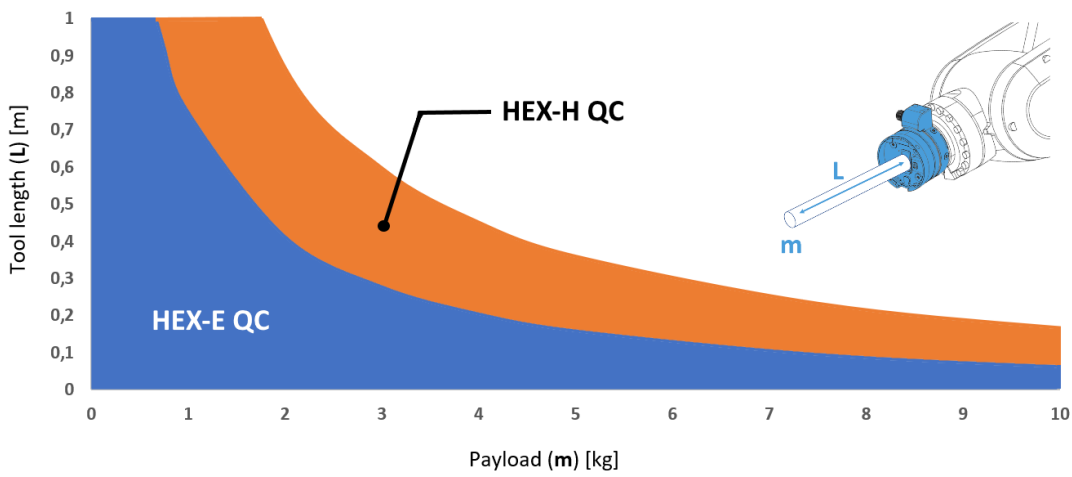

In the blue region it is recommended to use only the HEX-E QC.

1.4. HEX-E/H QC

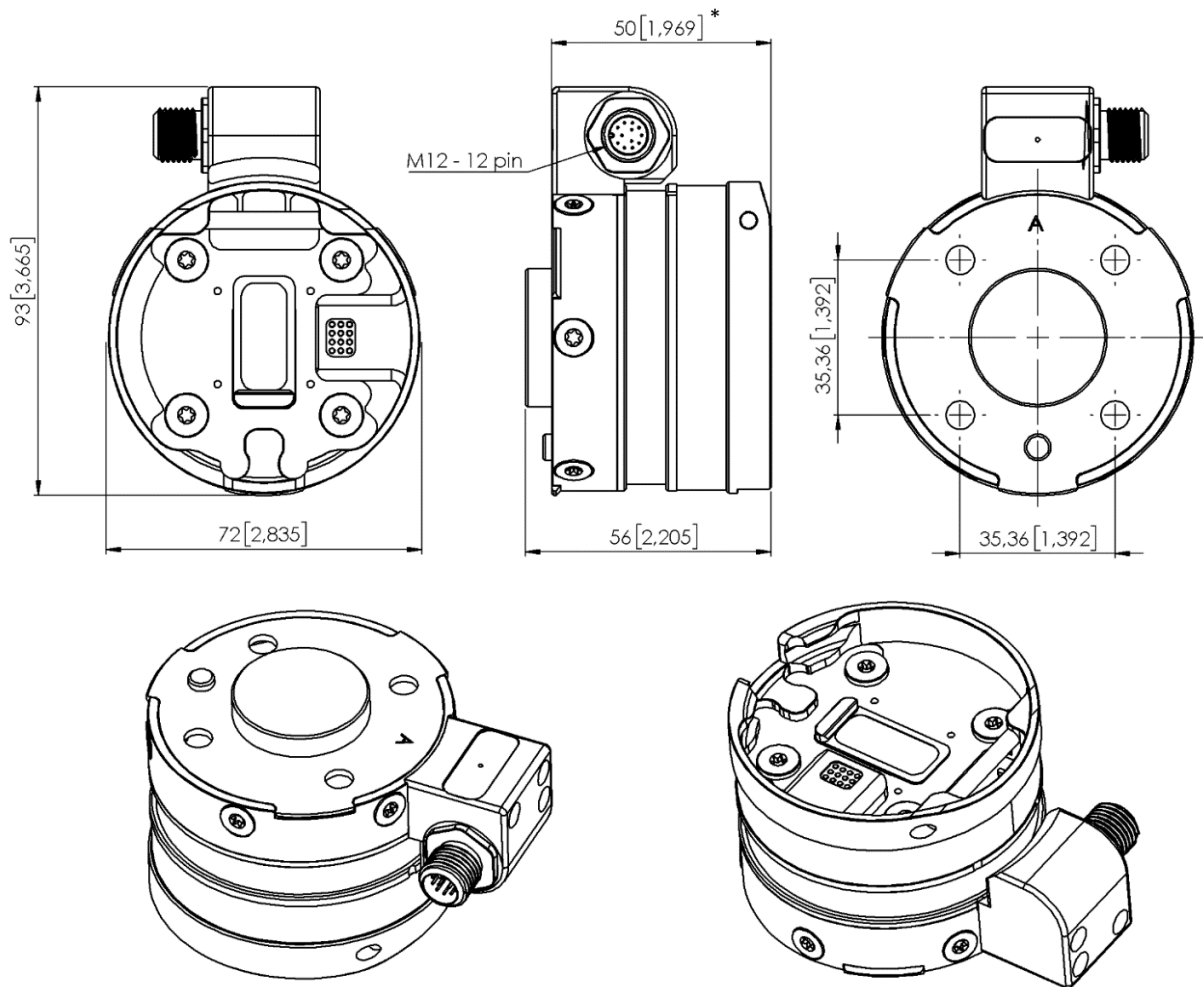

* Distance from Robot flange interface to OnRobot tool
 All dimensions are in mm and [inches].