

# LX

## Born to drive lifts

- Current vector control with or without PG
- High starting torque (200%/0.3 Hz Sensorless vector, 200%/0 Hz close loop vector control)
- IM&PM motor control
- Rescue function with flexible power supply (Control 220 VAC, Power from 48 VDC or 36 VAC)
- Static & Rotary advanced auto tuning
- Safety embedded: IEC 61508 SIL2
- Clock and calendar function
- Silent operation by Fan switch off by temperature
- One parameter Dynamic tuning
- Lift language (Hz, m/s, rpm...)
- Built-in logic programmability
- Universal dual encoder option (Endat, Hiperface, Line driver)
- Floor position auto-learning function of up to 40 floors
- Dedicated lift functionality (Brake control, Lift sequence...)
- CE, cULus, RoHS

## Ratings

- 400 V Class three-phase 3.7 to 18.5 kW



## System configuration

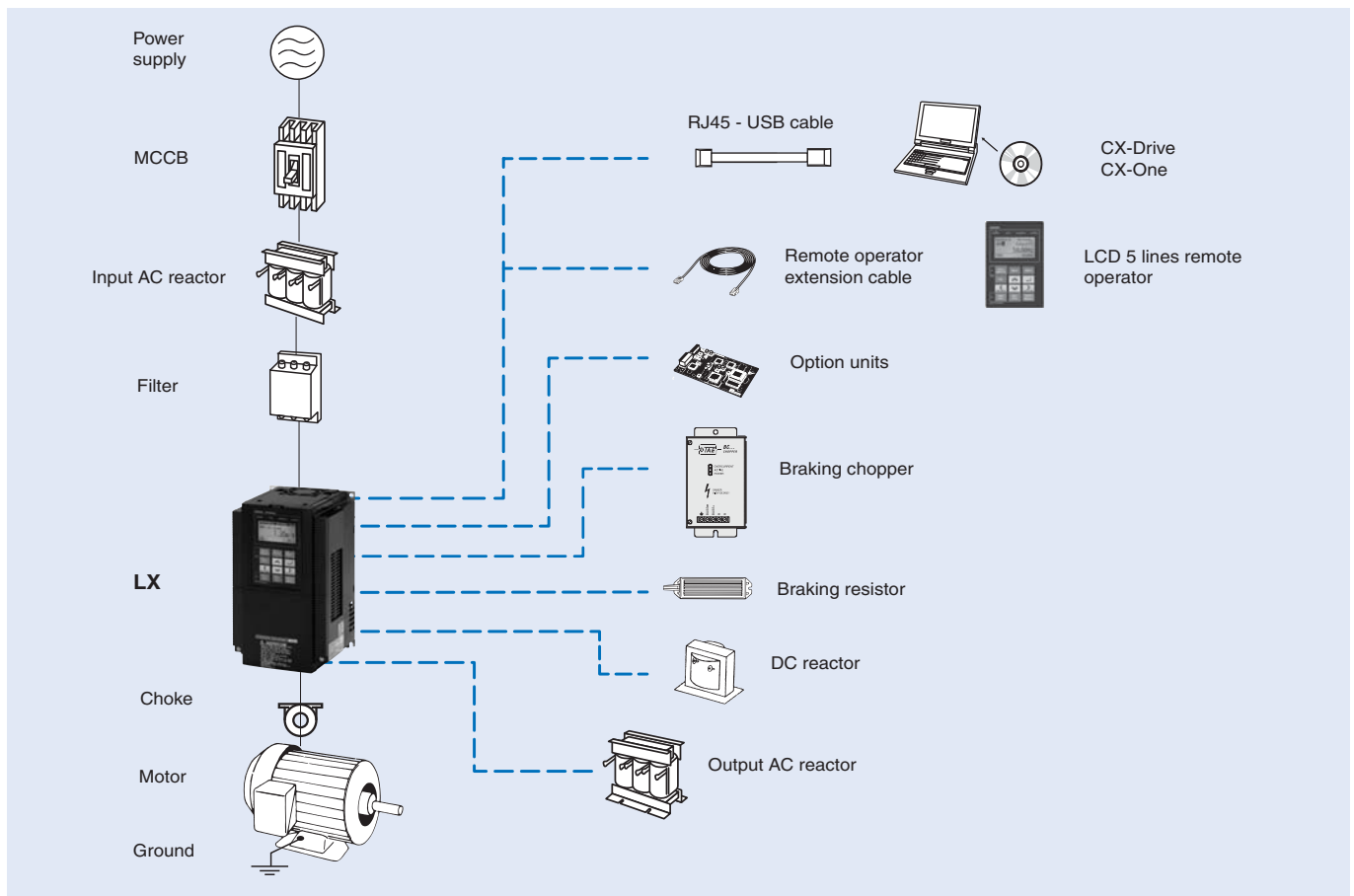

**Specifications**

**Type designation**

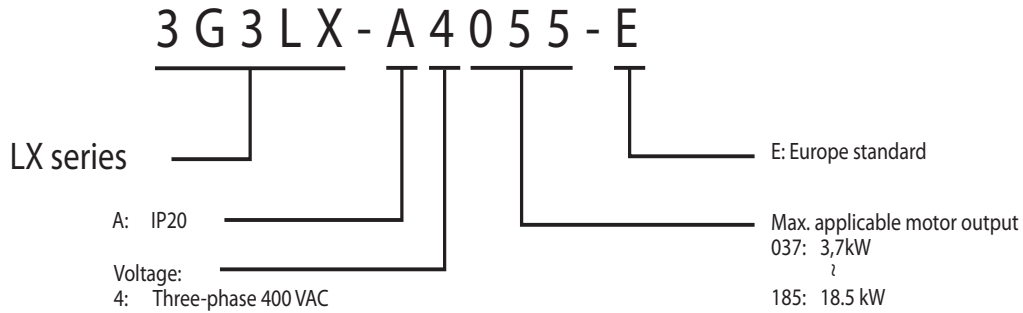

**400V class**

Three-phase: 3G3LX-□		A4037	A4040	A4055	A4075	A4110	A4150	A4185	
Motor kW <sup>*1</sup>		3.7	4.0	5.5	7.5	11.0	15.0	18.5	
Output characteristics	Inverter capacity kVA	5.7	5.9	9.7	13.1	17.3	22.1	26.3	
	400 V	6.8	7.1	11.6	15.8	20.7	26.6	31.5	
	480 V								
	Rated output current (A) (3min, 50%ED)	9	11	14	19	27	34	41	
Max. output voltage		Proportional to input voltage: 0...480 V							
Max. output frequency		400 Hz							
Power supply	Rated input voltage and frequency		Control supply: 1-phase 200...240 V 50/60 Hz						
			Power supply: 3-phase 380...480 V 50/60 Hz						
			Do not turn the inverter power on and off more often than once every 3 minutes						
	Allowable voltage fluctuation		-15%...+10%						
Allowable frequency fluctuation		5%							
Braking	Regenerative braking		Internal BRD circuit (external discharge resistor)						
	Minimum connectable resistance (Ω)		70	70	70	35	35	24	24
	Duty at minimum resistance		10%						
	Minimum resistance at continuous running (Ω)		200	200	200	150	150	100	100
Protective structure		IP20							
Cooling method		Forced air cooling							

<sup>\*1</sup> Based on a standard IM 3-Phase standard motor.

**Common specifications**

Model number	Specifications	
3G3LX□		
Control functions	Control methods	Phase-to-phase sinusoidal pulse with modulation PWM (V/f control for IM, Open loop vector control for IM, Closed loop vector control for IM, Closed loop vector control for PM)
	Output frequency range	0.00 to 400.00 Hz
	Frequency precision	Digital set value: ±0.01% of the max. frequency Analogue set value: ±0.2% of the max. frequency (25±10°C)
	Resolution of frequency set value	Digital set value: 0.01 Hz Analog input: 12 bit
	Resolution of output frequency	0.01 Hz
	Starting torque	200% at 0.3 Hz (Open loop vector control) 150% at 0 Hz (Closed loop vector control)
	Overload capability	150% for 30 sec
	External frequency set value	0 to 10 VDC (10 kΩ), -10 to 10 VDC (10 kΩ), 4 to 20 mA (100 Ω), RS485 Modbus
	Multi input frequency set values	7 multi speeds 10 speeds: Fast, Crawl, Intermediate 1/2/3, Releveling, inspection 1/2, Rescue 1/2
Functionality	Inputs signals	9 terminals (7 multi-function plus GS1 and GS2, NO/NC switchable, sink/source logic switchable) [Terminal function] SET (set 2nd motor data), FRS (Free-run stop), EXT (External trip), SFT (Software lock), RS (Reset), PCLR (Clear the current position), MI1 (General-purpose input 1), MI2 (General-purpose input 2), MI3 (General-purpose input 3), MI4 (General-purpose input 4), MI5 (General-purpose input 5), MI6 (General-purpose input 6), MI7 (General-purpose input 7), MI8 (General-purpose input 8), SPD1 (Multi-speed 1 setting), SPD2 (Multi-speed 2 setting), SPD3 (Multi-speed 3 setting), RESC (Rescue), INSP (Inspection), RL (Releveling), COK (Contactor check signal), BOK (Brake check signal), FP1 (Floor position 1), FP2 (Floor position 2), FP3 (Floor position 3), FP4 (Floor position 4), FP5 (Floor position 5), PAL (Auto learning data latch trigger), TCL (Torque bias latch trigger), LVS (Leveling signal), NFS (Near floor), CMC (control mode change), No allocation (no)
	Output signals	4 Relay output terminals: NO/NC switchable [Terminal function] RUN (Running), FA1 (Constant-speed reached), FA2 (Set frequency overreached), OL (Overload advance signal (1), AL (Alarm signal), FA3 (Set frequency reached), OTQ (Over-torque), IP (Instantaneous power failure), UV (Under voltage), TRQ (Torque limited), RNT (Operation time over), ONT (Plug-in time over), THM (Thermal alarm signal), ZS (0 Hz detection signal), DSE (Speed deviation maximum), POK (Positioning completed), FA4 (Set frequency overreached 2), FA5 (Set frequency reached 2), OL2 (Overload advance signal 2), WAC (Capacitor life warning), WAF (Cooling-fan speed drop), FR (starting contact signal), OHF (Heat sink overheat warning), LOC (Low-current indication signal), MO1 (General-purpose output 1), MO2 (General-purpose output 2), MO3 (General-purpose output 3), MO4 (General-purpose output 4), MO5 (General-purpose output 5), MO6 (General-purpose output 6), IRDY (Inverter ready), FWR (Forward rotation), RVR (Reverse rotation), MJA (Major failure), CON (Contactor control signal), BRK (Brake control signal), UPS (Light load search status), UPD (Light load search direction), GMON (Gate suppress monitor), MPS (Magnet pole position search)



Functionality	<b>Function for Lift</b>	Dedicated lift sequence built-in (Speed control, Direct position control), Direct control motor brake and contactor, Quick floor function, Torque bias at start (at closed loop vector control), ASR gain adjustment, Lift units (speed, position, Accel/Decel), Motor constant saved on inverter and encoder (Hiperface, EnDat), Emergency operation by UPS or battery (Control supply 1 phase 220 V, Power supply 48 to 600 VDC or 1 phase 220 V)
	<b>Analogue inputs</b>	Two analogue inputs 0 to 10 V and -10 to 10 V (10 k $\Omega$ ), one 4 to 20 mA (100 $\Omega$ ) (12 bits resolution)
	<b>Analogue outputs</b>	Analog voltage output (0 to 10 VDC 10 bits resolution), Analog current output (0 to 20 mA 10 bits resolution), Pulse train output (Max frequency 3.6 kHz, max current 1.2 mA)
	<b>Accel/Decel times</b>	0.01 to 3,600.0 s (linear/S-curve for lift, multi stage Acceleration/Deceleration)
Protection functions	<b>Display</b>	Status indicator LED's Run, Program, Power, Alarm, Hz, Amps, Volts,% Digital operator: Available to monitors: Output speed, Output current, Output torque, Output voltage, Input power, Electronic thermal overload, LAD speed, Motor temperature, Heat sink temperature, Output torque (signed value), General-purpose output YA (n)
	<b>Motor overload protection</b>	Electronic Thermal overload relay and PTC thermistor input
	<b>Instantaneous overcurrent</b>	200% of rated current for 3 seconds (170% for 15 kW and 18.5 kW)
	<b>Overload</b>	150% for 30 seconds
	<b>Overvoltage</b>	800 V
	<b>Cooling fin overheat</b>	Temperature monitor and error detection
	<b>Stall prevention level</b>	Stall prevention during acceleration and constant speed
	<b>Ground fault</b>	Detection at power on
Ambient conditions	<b>Lift specific protection</b>	Speed-reference error, Contactor error, Brake error, Wrong rotation detection, Over acceleration, Over speed, Speed deviation error
	<b>Degree of protection</b>	IP20
	<b>Ambient humidity</b>	90% RH or less (without condensation)
	<b>Storage temperature</b>	-20°C...+65°C (short-term temperature during transportation)
	<b>Ambient temperature</b>	-10°C to 40°C
	<b>Installation</b>	Indoor (no corrosive gas, dust, etc.)
	<b>Installation height</b>	Max. 1000 m
<b>Vibration</b>	5.9 m/s <sup>2</sup> (0.6 G), 10 to 55 Hz	

**Dimensions**

Figure 1

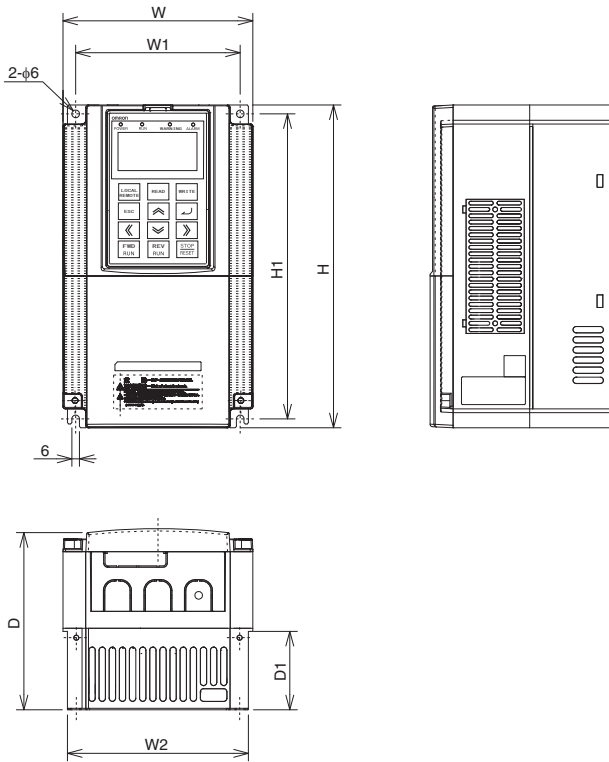

Figure 2

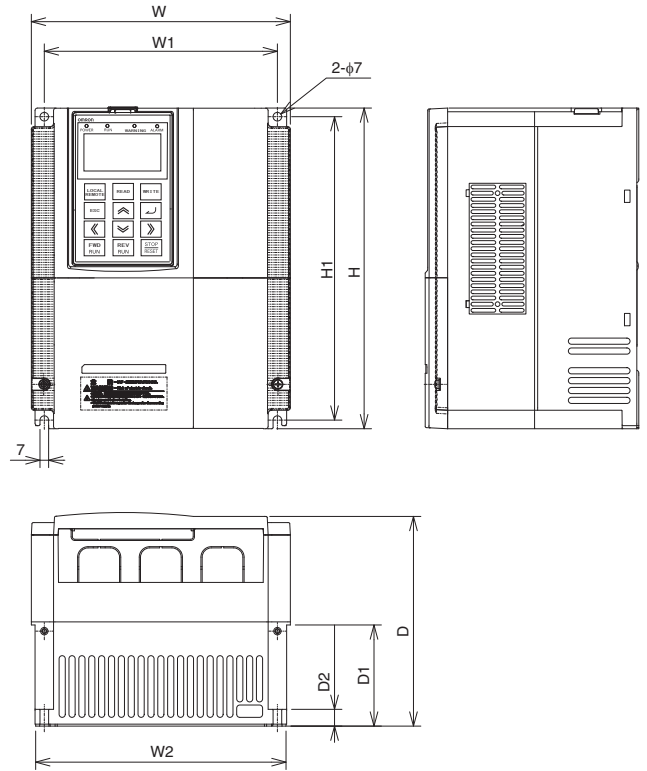
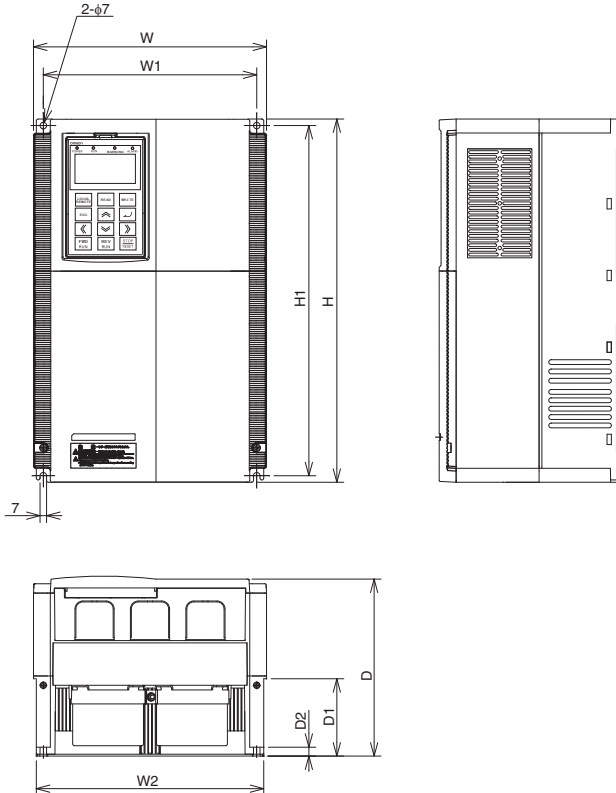

Figure 3



Voltage class	Inverter model LX□	Figure	Dimensions in mm								
			W	W1	W2	H	H1	D	D1	D2	Weight (kg)
Three-phase 400 V	A4037	1	150	130	143	255	241	140	62	-	3.5
	A4040	2	210	189	203	260	246	170	82	13.6	6
	A4055										
	A4075										
	A4110	3	250	229	244	390	376	190	83	9.5	14
	A4150										
A4185											

**Schaffner filters**

V	Inverter 3G3LX	Filter model	Dimensions (mm)								Weight kg
			L	W	H	X	Y	A	B		
3x400 V	A4037	AX-FIL3010-SE	300	145	40	286	110	6.5	M5	1.0	
	A4040	AX-FIL3015-SE	300	207	50	286	150	6.5	M6	1.5	
	A4055										
	A4075	AX-FIL3030-SE	300	207	50	286	150	6.5	M6	2.1	
	A4110	AX-FIL3053-SE	442	250	60	426	180	6.5	M6	4.1	
	A4150										
A4185											

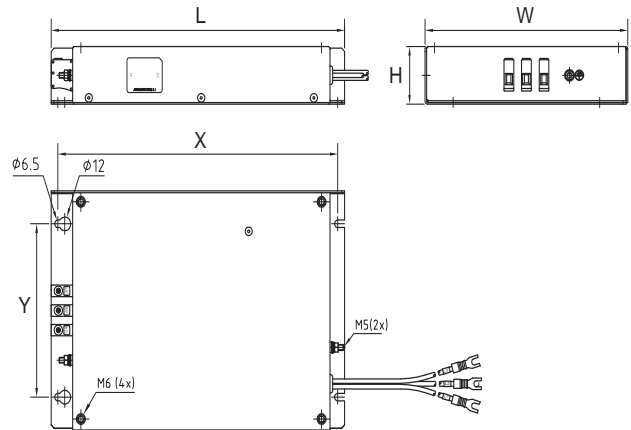

**Input AC Reactor**

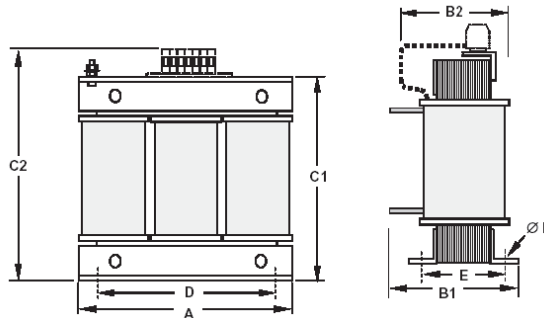

Voltage	Reference	Dimensions								Weight kg
		A	B1	B2	C1	C2	D	E	F	
400 V	AX-RAI03500100-DE	120	-	80	-	120	80	62	5.5	2.35
	AX-RAI01300170-DE	180		75		195				
	AX-RAI00740335-DE			85		190				
	AX-RAI00360500-DE			205						

**Input AC Reactor for EN12015**

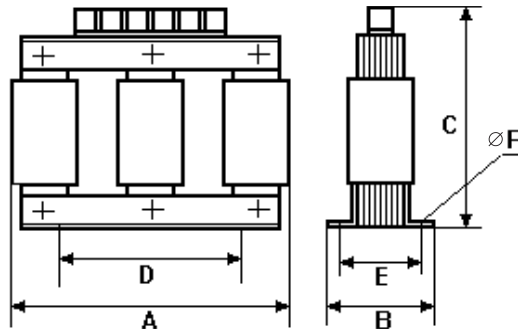

Voltage	Reference	Dimensions						Weight kg
		A	B	C	D	E	F	
400 V	AX-LX-RAI4037-CE	178	90	170	90	63	7	4.9
	AX-LX-RAI4040-CE	178	90	170	90	63	7	5.5
	AX-LX-RAI4055-CE	178	100	170	90	73	7	6.9
	AX-LX-RAI4075-CE	178	110	170	90	83	7	9.7
	AX-LX-RAI4110-CE	285	145	205	160	115	8	20
	AX-LX-RAI4150-CE	285	145	205	160	115	8	22
	AX-LX-RAI4185-CE	285	145	205	160	115	8	26

**DC Reactor**

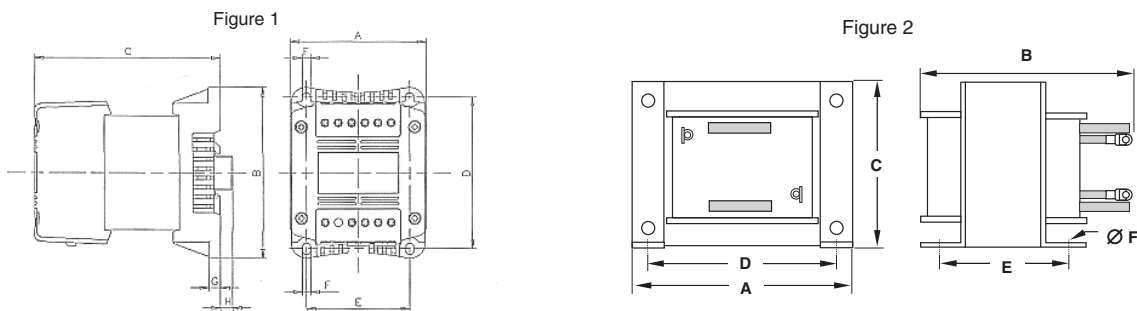

400 V										
Reference AX-RC	Fig	Dimensions								kg
		A	B	C	D	E	F	G	H	
06400116-DE	1	108	135	133	120	82	6.5	9.5	9.5	3.70
04410167-DE		120	152	136	135	94	7		-	5.20
03350219-DE				146				6.00		
02330307-DE		150	177	160	160	115	7	2	-	11.4
01750430-DE				183						14.3
01200644-DE	2	195	161	163	185	88	10	-	-	17.0

**Output AC Reactor**

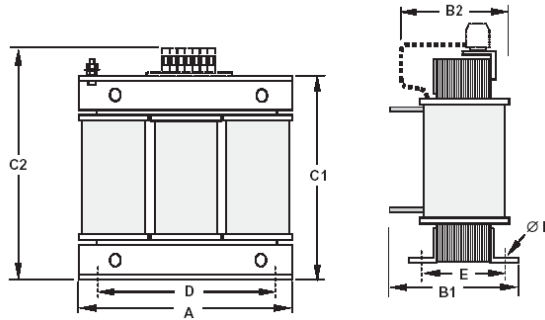

400 V							
Reference AX-RAO	Dimensions						kg
	A	B2	C2	D	E	F	
07300080-DE	180	85	190	140	55	6	5.5
04600110-DE	180	85	190	140	55	6	5.5
03600160-DE	180	85	205	140	55	6	6.5
02500220-DE	180	95	205	140	65	6	9.1
02000320-DE	240	110	275	200	75	6	16.0
01650400-DE	240	110	275	200	75	6	16.0

**Chokes**

Reference	D diameter	Motor kW	Dimensions						Weight kg
			L	W	H	X	Y	m	
AX-FER2515-RE	25	< 15	105	25	62	90	-	5	0.2
AX-FER5045-RE	50	< 18.5	150	50	110	125	30	5	0.7

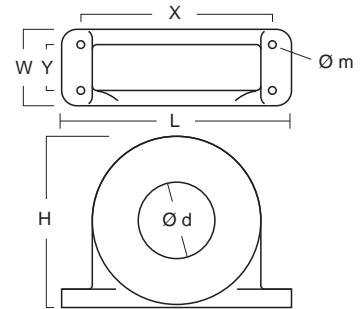

**Resistor dimensions**

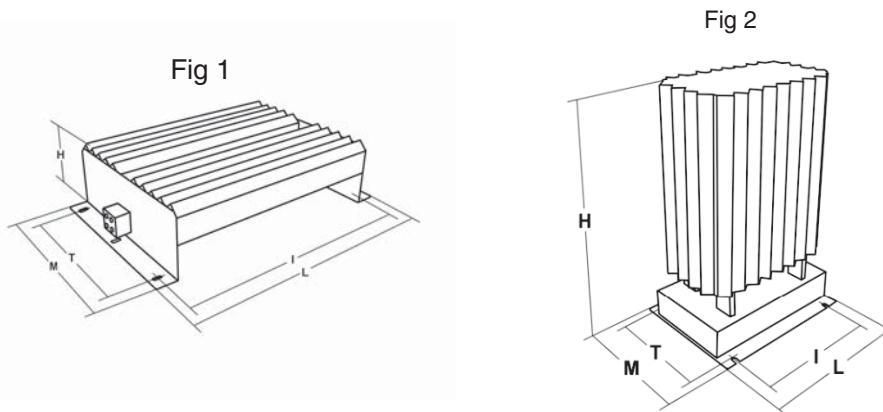

Type	Fig	Dimensions					Weight kg
		L	H	M	I	T	
AX-REM02K1110-IE	1	310	100	240	295	210	7
AX-REM03K5085-IE		365	100	240	350	210	8
AX-REM19K0032-IE	2	206	350	140	190	50	8.1

Installation

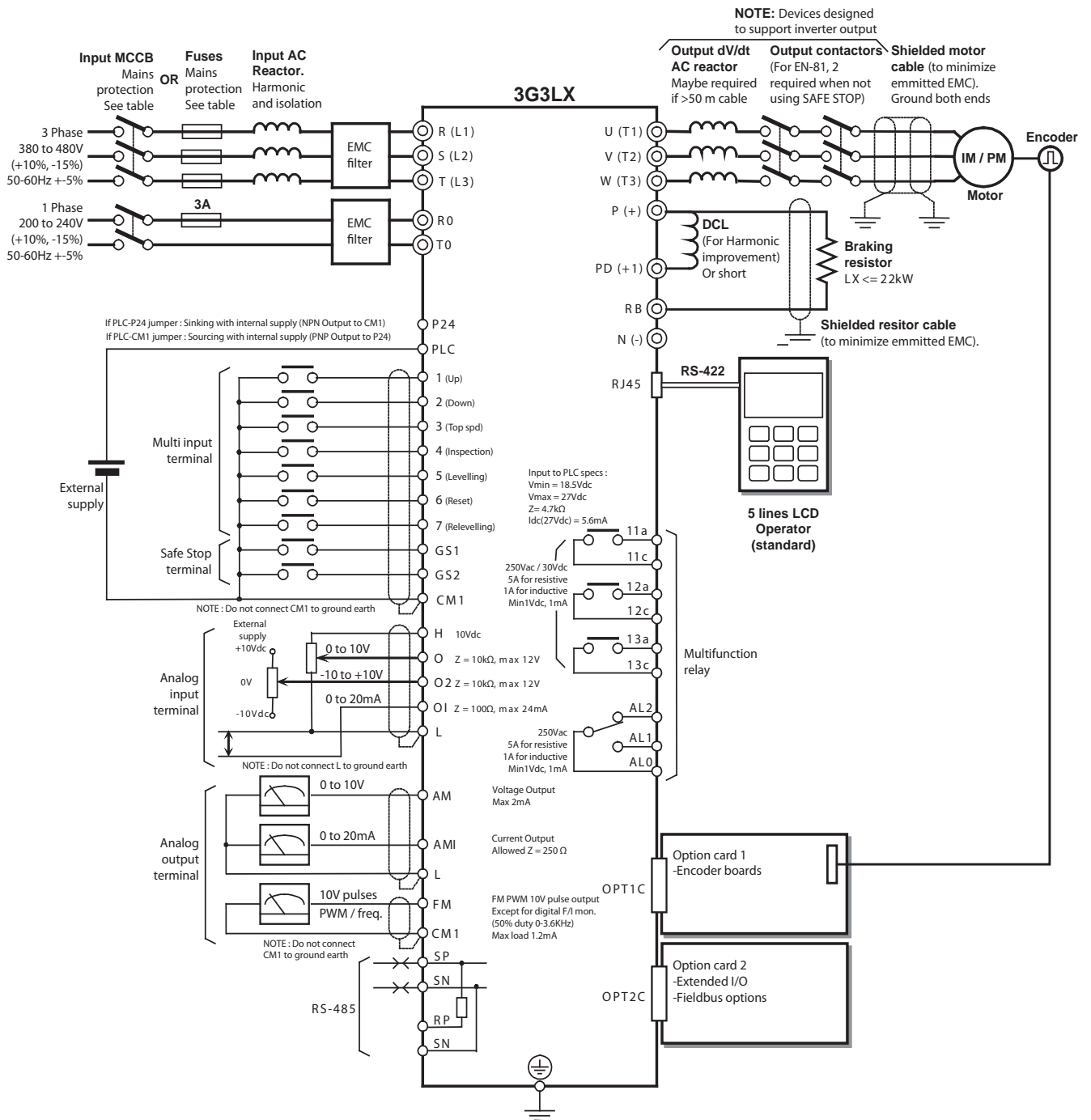

Terminal block specifications

Terminal	Name	Function (signal level)
R/L1, S/L2, T/L3	Main circuit power supply input	Three phase 380-480 V
Ro, To	Control circuit power supply	Single phase 200-240 V for any voltage class
U/T1, V/T2, W/T3	Inverter output	Three phase motor connection (IM/PM)
PD/+1, P/+	External DC reactor terminal	Normally connected by the short-circuit bar. Remove the short-circuit bar between +1 and P/+2 when a DC reactor is connected.
P/+, RB	External brake resistor	For connection of an external braking resistor. (Integrated braking transistor for 22 kW or lower size)
P/+, N/-	Regenerative braking unit connection terminal	Connect optional regenerative braking units.
⊕	Grounding	Earthing terminal. Please ground large ground.





## Control circuit

Type	No.	Signal name	Function	Signal level
Frequency reference input	H	Power supply for analog potentiometer	10 VDC 20 mA max	
	O	Analog voltage input Speed Reference/Torque bias (load cell)	0 to 12 VDC (10 kΩ)	
	O2	Analog voltage input Speed Reference/Torque bias (load cell)	0 to +/- 12 VDC (10 kΩ)	
	OI	Analog current input Speed Reference/Torque bias (load cell)	4 to 20 mA (100 Ω)	
	L	analog power supply common	-	
Monitor Output	AM	Multi-function analog voltage output	Factory setting: Output frequency	2 mA max
	AMI	Multi-function analog current output	Factory setting: Output frequency	4 to 20 mA (max imp 250 Ω)
	FM	PWM monitor output	Factory setting: Output frequency	0 to 10 VDC Max 3.6 kHz
Power Supply	P24	Internal 24 VDC	Power supply for contact input signal	100 mA max
	CM1	Input common	Common terminal for P24, TH and analog monitor (AM, AMI, FM) terminals Note: Do not connect to ground earth	
Function Selection	1	Multi-function input When safety inputs GS1 and GS2 are enabled by hardware dip-switch SW1, multifunction settings 78:GS1 and 79:GS2 are compulsory.  When safety inputs are disabled, GS1 and GS2 can be used as standard multifunction inputs.	Factory setting: Up (UP)	27 VDC max Input imp 4.7 kΩ Max current 5.6 mA On: 18 VDC or more
	2		Factory setting: Down (DWN)	
	3		Factory setting: Multi-speed 2 setting (SPD2)	
	4		Factory setting: Inspection 1 (INSP1)	
	5		Factory setting: Leveling signal (LVS)	
	6		Factory setting: Reset (RS)	
	7		Factory setting: Inspection 2 (INSP2)	
	GS1		Factory setting: Gate suppress 1 (GS1)	
	GS2		Factory setting: Gate suppress 2 (GS2)	
	PLC		Multi-function input common	
Status/Factor	11a	Multi-function output	Factory setting: Brake control signal (BRK)	Maximum relay contact capacity: 250VAC 5 A (R load) 250VAC 1 A (I load) 30 VDC 5 A (R load) 30 VDC 1 A (I load) Minimum capacity 1 VDC 1 mA
	11c			
	12a		Factory setting: Contactor control signal (CON)	
	12c			
	13a		Factory setting: Inverter ready (IRDY)	
	13c			
Relay output	AL1	Relay output (Normally close)	Factory setting: Alarm signal (AL) Under normal operation AL1-AL0 open AL2-AL0 close	R load AL1-AL0 250 VAC 2 A AL2-AL0 250 VAC 1 A I load 250 VAC 0.2 A
	AL2	Relay output (Normally open)		
	AL0	Relay output common		
Sensor	TH	External thermistor input terminal	SC terminal functions as the common terminal 100 mW minimum Impedance at temperature error: 3 kΩ	0 to 8 VDC
Comms	SP	RS485 Modbus terminals	-	Differential input
	SN			
	RP	RS485 terminating resistor terminals		
	SN			

**Inverter heat loss**  
**Three-phase 400 V class**

Model 3G3LX-		A4037	A4040	A4055	A4075	A4110	A4150	A4185
Inverter capacity kVA	400 V	5.7	5.9	9.7	13.1	17.3	22.1	26.3
	480 V	6.8	7.1	11.6	15.8	20.7	26.6	31.5
Rated current (A)		9	11	14	19	25	32	38
Heat loss W	Losses at 70% load	179	242	242	312	435	575	698
	Losses at 100% load	235	325	325	425	600	800	975
Efficiency at rated output		94.0	94.4	94.4	94.6	94.8	94.9	95.0
Cooling Method		Forced-air-cooling						

**Input AC Reactor**

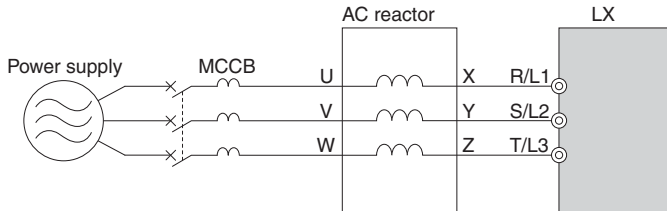

400 V class			
Max. applicable motor output kW	Reference	Current value A	Inductance mH
3.7	AX-RAI03500100-DE	10.0	3.5
4.0 to 7.5	AX-RAI01300170-DE	17.0	1.3
11.0 to 15.0	AX-RAI00740335-DE	33.5	0.74
18.5	AX-RAI00360500-DE	50.0	0.36

**Input AC Reactor for EN12015**

400 V class				
Max. applicable motor output kW	Reference	Current value A	Resistance mΩ	Inductance mH
3.7	AX-LX-RAI4037-CE	9	150	10.6
4.0	AX-LX-RAI4040-CE	11	129	8.7
5.5	AX-LX-RAI4055-CE	14	100	6.8
7.5	AX-LX-RAI4075-CE	19	50	5
11.0	AX-LX-RAI4110-CE	27	21	3.5
15.0	AX-LX-RAI4150-CE	34	19	2.8
18.5	AX-LX-RAI4185-CE	41	15	2.3

**DC Reactor**

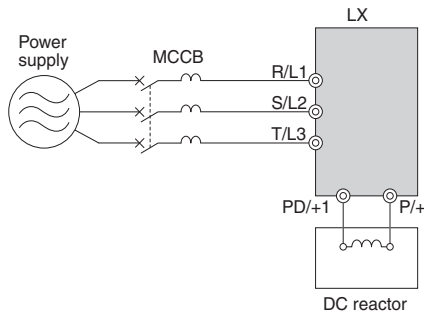

400 V class			
Max. applicable motor output kW	Reference	Current value A	Inductance mH
3.7	AX-RC06400116-DE	11.6	6.40
5.5	AX-RC04410167-DE	16.7	4.41
7.5	AX-RC03350219-DE	21.9	3.35
11.0	AX-RC02330307-DE	30.7	2.33
15.0	AX-RC01750430-DE	43.0	1.75
18.5	AX-RC01200644-DE	64.4	1.20

**Output AC Reactor**

400 V class			
Max. applicable motor output kW	Reference	Current value A	Inductance mH
4.0	AX-RAO07300080-DE	8.0	7.30
5.5	AX-RAO04600110-DE	11.0	4.60
7.5	AX-RAO03600160-DE	16.0	3.60
11	AX-RAO02500220-DE	22.0	2.50
15	AX-RAO02000320-DE	32.0	2.00
18.5	AX-RAO01650400-DE	40.0	1.65

**Ordering information**

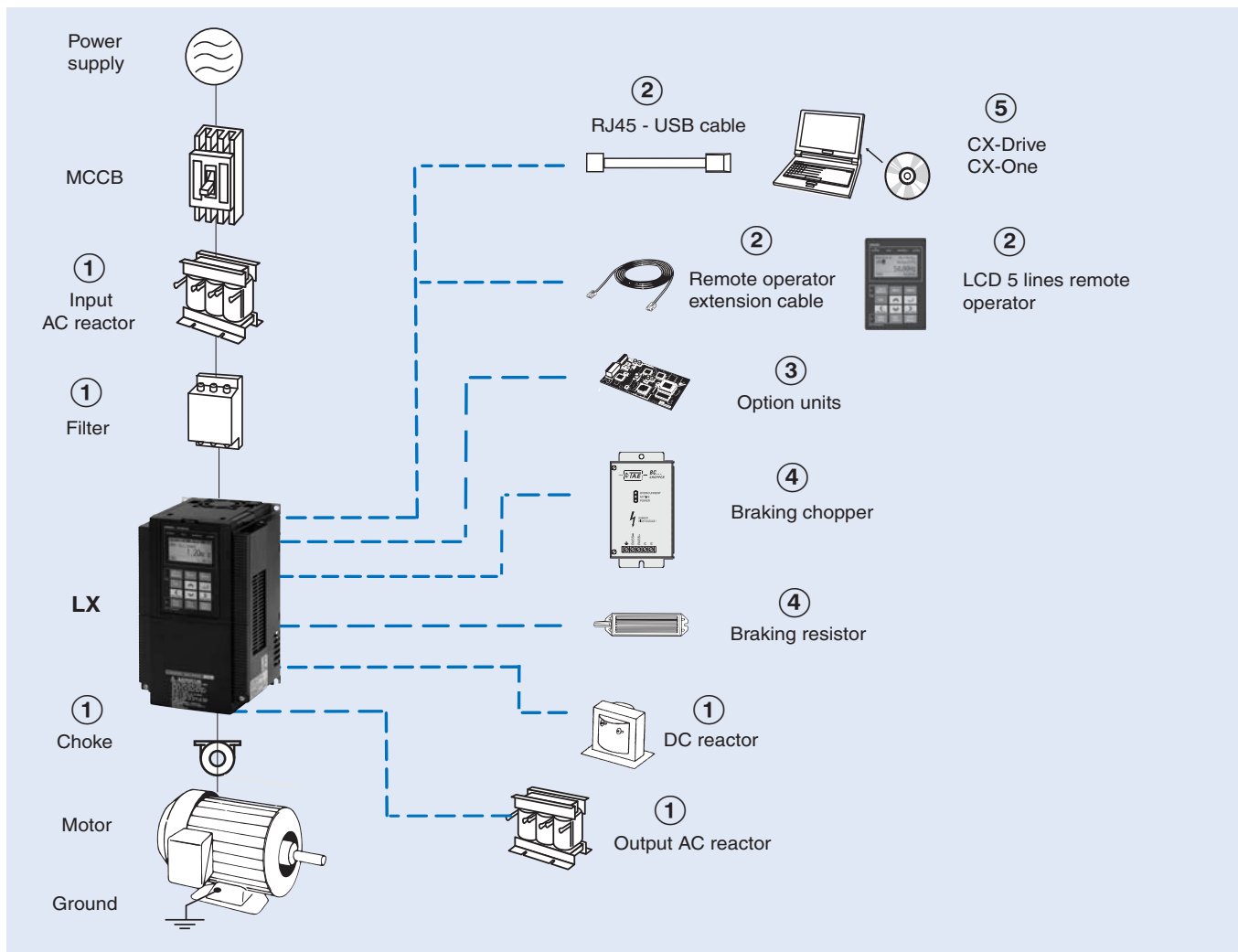

**3G3LX**

Voltage class	Specifications		Model
	Max motor kW	Rated current A	3G3LX-
Three-phase 400V	3.7	9	A4037-E
	4.0	11	A4040-E
	5.5	14	A4055-E
	7.5	19	A4075-E
	11	27	A4110-E
	15	34	A4150-E
	18.5	41	A4185-E

**① Line filters**

Line filter						
Type	Voltage class	Model 3G3LX-□	Reference	Rated current (A)	Leakage Nom/Max	kg
Filter for main power supply	Three-phase 400 V	A4037	AX-FIL3010-SE	10	3.3/53 mA	1.0
		A4040/A4055	AX-FIL3015-SE	15	3.3/53 mA	1.5
		A4075/A4110	AX-FIL3030-SE	30	3.4/58 mA	2.1
		A4150/A4185	AX-FIL3053-SE	53	3.4/58 mA	4.1
Filter for control power supply <sup>*1</sup>	Single-phase 200 V	All models	AX-FILC2008-SE	8	0.73/1.46 mA	0.17

<sup>\*1</sup> To meet EMC regulation the AX-FILC2008-SE filter on the control power supply is needed.

## ① Input AC Reactors

3-Phase 400 VAC	
Inverter Model 3G3LX-□	AC Reactor Reference
A4037	AX-RAI03500100-DE
A4040/A4055/A4075	AX-RAI01300170-DE
A4110/A4150	AX-RAI00740335-DE
A4185	AX-RAI00360500-DE

## ① Input AC Reactors for EN12015

3-Phase 400 VAC	
Inverter Model 3G3LX-□	AC Reactor Reference
A4037	AX-LX-RAI4037-CE
A4040	AX-LX-RAI4040-CE
A4055	AX-LX-RAI4055-CE
A4075	AX-LX-RAI4075-CE
A4110	AX-LX-RAI4110-CE
A4150	AX-LX-RAI4150-CE
A4185	AX-LX-RAI4185-CE

## ① DC Reactors

3-Phase 400 VAC	
Inverter Model 3G3LX-□	AC Reactor Reference
A4037	AX-RC06400116-DE
A4040/A4055	AX-RC04410167-DE
A4075	AX-RC03350219-DE
A4110	AX-RC02330307-DE
A4150	AX-RC01750430-DE
A4185	AX-RC01200644-DE

## ① Chokes

Model	Diameter	Description
AX-FER2515-RE	25	For 15 kW motors or below
AX-FER5045-RE	50	For 18.5 kW motors

## ① Output AC Reactor

400V	
Model 3G3LX-□	Reference
A4040	AX-RAO07300080-DE
A4055	AX-RAO04600110-DE
A4075	AX-RAO03600160-DE
A4110	AX-RAO02500220-DE
A4150	AX-RAO02000320-DE
A4185	AX-RAO01650400-DE

## ② Accessories

Types	Model	Description	Functions
Digital operator	AX-OP05-E	LCD remote operator	5 Line LCD remote operator with copy function, cable length max. 3 m. <sup>*1</sup>
	3G3AX-CAJOP300-EE	Remote operator cable	3 meters cable for connecting remote operator
	3G3AX-OP01	LED remote operator	LED remote operator, cable length max. 3m
	4X-KITMINI	Mounting kit for LED operator	Mounting kit for LED operator on panel
Accessories	3G3AX-PCACN2	USB converter/USB cable	RJ45 to USB connection cable
	USB-converter cable		

\*1 Please note, models with firmware 4287 and 4288, the operator will only display 2 lines of text.

## ③ Option boards

Types	Model	Description	Functions
Encoder Feedback	3G3AX-PG	PG speed controller option card	Phase A,B and Z pulse (differential pulse) inputs (RS-422) Pulse train position command input (RS-422) Pulse monitor output (RS-422) PG frequency range: 100 kHz max
	3G3AX-ABS		Two encoder input board supporting Phase A,B and Z pulse (differential pulse) inputs (RS-422) EnDat 2.1 and 2.2 Hiperface
	3G3AX-ABS30		3G3AX-ABS → PG frequency range: 100 kHz max 3G3AX-ABS30 → PG frequency range: 30 KHz max to improve noise immunity
Option	SJ-EIO	Expansion I/O board	5 digital inputs, 2 relay output and 1 open collector output



④ Braking unit, braking resistor unit

Inverter						Braking resistor unit		
Voltage	Max. motor kW	Inverter 3G3LX□	Braking Unit AX-BCR□	Connectable min. resistance Ω	Connectable resistance at continuous running Ω	External resistor 10%ED 10 sec max for built-in 5 sec max for Braking Unit		Braking torque %
		3-phase				Type AX-	Resist Ω	
400 V (Three-phase)	3.7	4037	Built-in	70	200	REM02K1110-IE	110	55
	4.0	4040		70	200	REM02K1110-IE	110	50
	5.5	4055		70	200	REM02K1110-IE	110	40
	7.5	4075		35	150	REM03K5085-IE	85	45
	11.0	4110		35	150	REM03K5085-IE	85	30
	15.0	4150		24	100	REM19K0032-IE	32	65
	18.5	4185		24	100	REM19K0032-IE	32	55

Recommended values with a 2:1 roping ratio, 1m/s lift speed and medium lift usage

⑤ Computer software

Types	Model	Description	Installation
Software	CX-Drive	Computer software	Configuration and monitoring software tool
	CX-One	Computer software	Configuration and monitoring software tool

ALL DIMENSIONS SHOWN ARE IN MILLIMETERS.  
To convert millimeters into inches, multiply by 0.03937. To convert grams into ounces, multiply by 0.03527.