

# Cobra 450

## Mid-size SCARA robot for material handling, assembly, precision machining and adhesive application

- Ethernet capability to control the robot through the familiar programming language (IEC 61131-3) of Machine Automation Controller NJ/NX/NY Series
- Good repeatability for precision assembly
- High Payload for using tools for screw-driving and adhesive application
- Minimum footprint with separate controller
- Robot with integral power and signal cables
- Reach 450 mm
- Maximum Payload 5 kg
- Weight 29 kg



## Specifications

Product name		Cobra
	Size	450
Part Number		1720[ ]-14500
Number of axes		4
Mounting		table/floor
Reach		450 mm
Maximum Payload		5 kg
Repeatability	XY	±0.02 mm
	Z	±0.01 mm
	Theta	±0.005°
Joint Range	Joint 1	±125°
	Joint 2	±145°
	Joint 3	200 mm
	Joint 4	±360°
Inertia Moment (Max.)	Joint 4	450 kg-cm <sup>2</sup>
Joint Speeds	Joint 1	450°/s
	Joint 2	720°/s
	Joint 3	1100 mm/s
	Joint 4	1940°/s
Cycle times, *1 with 2.0 kg Payload	Burst	0.49 s
	Sustained	0.64 s
Power Requirements		24 VDC: 6 A 200 to 240 VAC: 10 A, single-phase
Protection		IP20
Clean Class		---
Environment Requirements	Ambient Temperature	5 to 40°C
	Humidity Range	35 to 90% (non-condensing)
Weight		29 kg
Basic configuration	Controller	eMotionBlox-40
	On-board I/O (Input/Output)	12/8
	Conveyor tracking input	2
	RS-232C serial communications port	1
	Programming environment	ACE, PackXpert, ePLC
	ACE Sight	Yes
	ePLC Connect	Yes
Connectable controller *2		eMotionBlox-40M, SmartController EX, NJ/NX/NY Series

\*1. Adept cycle, in mm 25/305/25 (seconds, at 20°C ambient)

\*2. Choose a controller to suit your application.

# Dimensions

(Unit: mm)

## Cobra 450

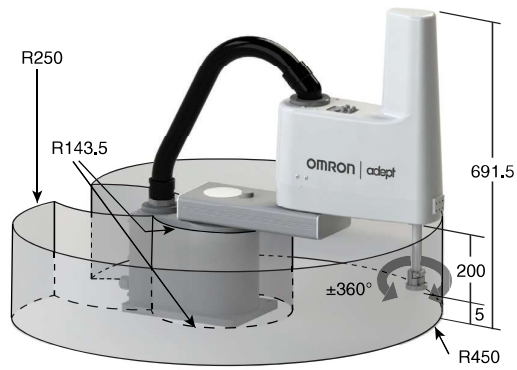

## eMotionBlox-40M



## Flange

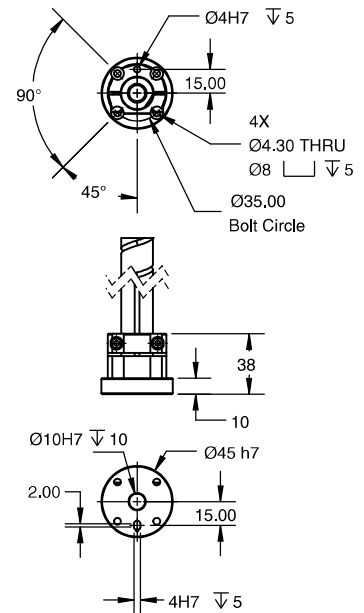

## Footprint

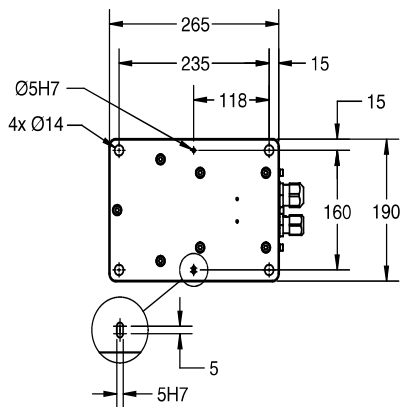

## Front panel (option)



# Robot Parts Code and Bundled Accessories

Type	Cobra 450	Cobra 450 Add-On
<b>Cobra 450</b>	17201-14500	17203-14500
<b>Overview</b>	Robot + Integral Power and Signal Cables + eMotionBlox-40M amplifier with fully-integrated controls	Robot + Integral Power and Signal Cables + eMotionBlox-40M amplifier + required connection cables
<b>Purpose</b>	Typical for use in single-robot system	Typically added to systems with an existing SmartController EX to create multi-robot systems
<b>Bundled Cable/Accessories</b>	<ul style="list-style-type: none"> <li>XSYSTEM cable with jumpers, 1.8 m/6 ft (13323-000)</li> </ul>	<ul style="list-style-type: none"> <li>XSYSTEM cable with jumpers, 1.8 m/6 ft (13323-000)</li> <li>XSYS cable, 4.5 m/15 ft (11585-000)</li> <li>DB9 splitter (00411-000)</li> <li>1394 latch cable, 4.5 m/15 ft (13632-045)</li> <li>eV+ license to connect to controller (14529-103)</li> </ul>