

Articulated Robots

Viper 850

Articulated robot for machining, assembly, and material handling

- Ethernet capability to control the robot through the familiar programming language (IEC 61131-3) of Machine Automation Controller NJ/NX/NY Series
- Diagnostics display enables faster trouble shooting
- High-resolution, absolute encoders to provide high accuracy, superior slow-speed following, and easy calibration
- High-efficiency, low-inertia Harmonic Drives and a lightweight arm to deliver maximum acceleration
- Reach 855 mm
- Maximum payload 5 kg
- Weight 36 kg



Specifications

Product name		Viper		
		850		
Size		Standard	Cleanroom	IP54/65
Cleanroom/IP				
Part Number		1720[]-38000	1720[]-38020	1720[]-38010
Mounting		Table/Floor/Inverted		
Number of axes		6		
Reach		855 mm		
Maximum Payload		5 kg		
Repeatability	XYZ	±0.03 mm		
Joint Range	Joint 1	±170°		
	Joint 2	-190°, +45°		
	Joint 3	-29°, +256°		
	Joint 4	±190°		
	Joint 5	±120°		
	Joint 6	±360°		
Inertia Moment (Max.)	Joint 4	0.295 kgm ²		
	Joint 5	0.295 kgm ²		
	Joint 6	0.045 kgm ²		
Joint Speeds	Joint 1	250°/s		
	Joint 2	250°/s		
	Joint 3	250°/s		
	Joint 4	375°/s		
	Joint 5	375°/s		
	Joint 6	600°/s		

Product name		Viper		
		850		
Size		Standard	Cleanroom	IP54/65
Cleanroom/IP				
Power Requirements		24 VDC: 6 A 200 to 240 VAC: 10 A, single-phase		
Protection	Base	IP40	IP40	IP54
	Robot Joints (J4, J5, J6)	IP40	IP40	IP65
Clean Class		---	Class10	---
Environment Requirements	Ambient Temperature	5 to 40°C		
	Humidity Range	5 to 90% (non-condensing)		
Weight		36 kg		
cULus Compliant		---		
Basic configuration	Controller	eMotionBlox-60R		
	On-board I/O (Input/Output)	12/8		
	Conveyor tracking input	2		
	RS-232C serial communications port	1		
	Programming environment	ACE, PackXpert, ePLC		
	ACE Sight	Yes		
	ePLC Connect	Yes		
	ePLC I/O	Yes		
Connectable controller *1		eMotionBlox-60R, SmartController EX, NJ/NX/NY Series *2		

*1. Choose a controller to suit your application.

*2. The robot version 2.3.C or later is required to connect with the NJ/NX/NY Series.

Dimensions

(Unit: mm)

Viper 850

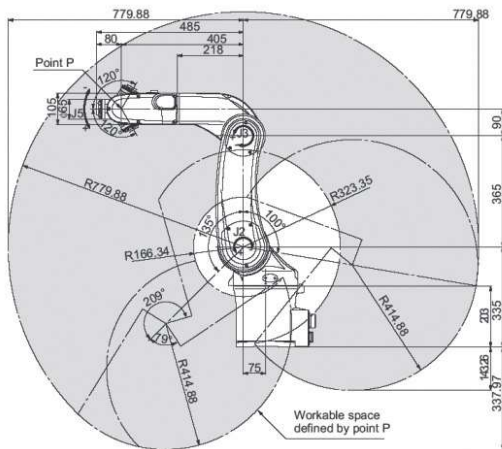

Footprint

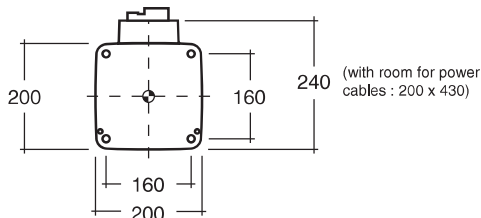

eMotionBlox-60R

Weight : 9.3 kg

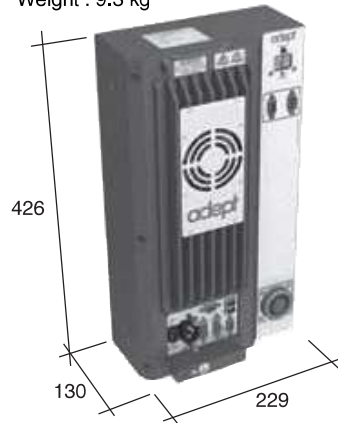

Front panel



Flange

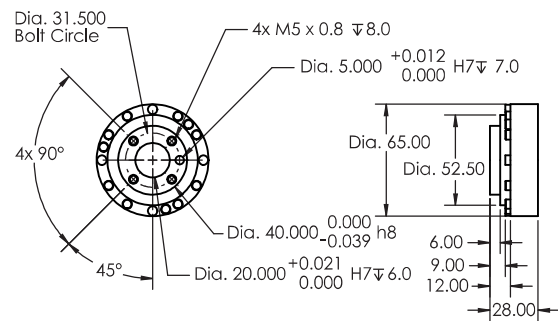

Robot Parts Code and Bundled Accessories

Type	Viper			Viper Add-On			
	Cleanroom/IP	Standard	Cleanroom	IP54/65	Standard	Cleanroom	IP54/65
Viper 850	17201-38000	17201-38020	17201-38010	17203-38000	17203-38020	17203-38010	
Overview	Robot + eMotionBlox-60R amplifier with fully integrated controls			Robot + eMotionBlox-60R + required connection cables			
Purpose	Typical for use in single robot system			Typically added to systems with an existing SmartController EX to create multi-robot systems			
Bundled Accessories	<ul style="list-style-type: none"> XSYSTEM cable with jumpers, 1.8 m/6 ft (13323-000) Front panel kit (90356-10358) Arm power/signal cable, 4 m/13 ft (05020-000) 			<ul style="list-style-type: none"> XSYSTEM cable with jumpers, 1.8 m/6 ft (13323-000) XSYS cable, 4.5 m/15 ft (11585-000) DB9 splitter (00411-000) 1394 latch cable, 4.5 m/15 ft (13632-045) eV+ license to connect to controller (14529-103) 			