

Relays with Forcibly Guided Contacts G7S-□-E

Lineup Now Includes 10-A Models

- EN50205 Class A, approved by VDE.
- Supports the CE marking of machinery (Machinery Directive).
- The G7S-□-E contributes to the protection of machinery when used as part of an interlocking circuit.
- Most suitable for safety circuits in industrial machinery.
- Track-mounting and Back-mounting Sockets are available.

Note: Be sure to refer to the *Precautions* on page 4.

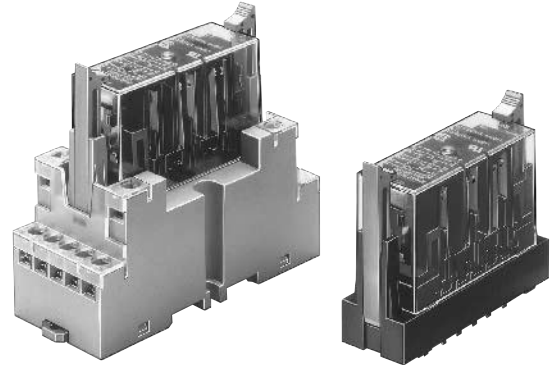

NEW



Model Number Structure

Model Number Legend

G7S-□₁A□₂B-E

1. NO Contact Poles

- 4: 4PST-NO
- 3: 3PST-NO

2. NC Contact Poles

- 2: DPST-NC
- 3: 3PST-NC

Ordering Information

Relays with Forcibly Guided Contacts

Type	Poles	Contact form	Rated voltage (V)	Model
Standard	6 poles	4PST-NO, DPST-NC	24 VDC	G7S-4A2B-E
		3PST-NO, 3PST-NC		G7S-3A3B-E

Accessories

Sockets

Type	Rated voltage	Model
Track-mounting	Common for track mounting and screw mounting 24 VDC	P7S-14F-END
Back-mounting	PCB terminals ---	P7S-14P-E

Specifications

Ratings

Coil

Rated voltage	Rated current	Coil resistance	Must operate voltage	Must release voltage	Max. voltage	Power consumption
24 VDC	30 mA	800 Ω	80% max. (V)	10% min. (V)	110% (V)	Approx. 0.8 W

Note: 1. The rated current and coil resistance are measured at a coil temperature of 23°C with tolerances of ±15%.

2. Performance characteristics are based on a coil temperature of 23°C.

3. The maximum voltage is based on an ambient operating temperature of 23°C maximum.

Contacts

Load		Resistive load (cosφ =1)	Inductive load (See note.)
Rated load	NO contact	10 A at 250 VAC 10 A at 30 VDC	AC-15: 5 A at 240 VAC DC-13: 2 A at 24 VDC
	NC contact	6 A at 250 VAC 6 A at 30 VDC	AC-15: 3 A at 240 VAC DC-13: 2 A at 24 VDC
Rated carry current	NO contact	10 A	
	NC contact	6 A	
Maximum switching voltage		250 VAC, 30 VDC	
Maximum switching current	NO contact	10 A	
	NC contact	6 A	

Note: In the above table, cosφ = 0.3 for AC-15 inductive loads and L/R = 96 ms for DC-13 inductive loads.

Characteristics

Sockets

Model	Continuous current	Dielectric strength	Insulation resistance
P7S-14□-E□	10 A	2000 VAC for 1 min. between terminals	1000 MΩ min. (See note 2.)

Note: 1. When using the P7S-14F-END at 24 VDC, use at an ambient operating temperature from -25 to 55°C.

2. Measurement conditions: Measurement of the same points as for the dielectric strength at 500 VDC.

Relays with Forcibly Guided Contacts

Contact resistance (See note 2.)		100 mΩ max.
Operate time (See note 3.)		50 ms max.
Release time (See note 3.)		50 ms max.
Maximum operating frequency	Mechanical	18,000 operations/hr
	Rated load	1,800 operations/hr
Insulation resistance (See note 4.)		100 MΩ min.
Dielectric strength (See notes 5 and 6.)		Between coil and contacts: Between coil and pole 3 or coil and pole 4: 4,000 VAC, 50/60 Hz for 1 min Other than the above: 2,500 VAC, 50/60 Hz for 1 min Between different poles: Between pole 1, 3, or 5 and pole 2, 4, or 6: 4,000 VAC, 50/60 Hz for 1 min Other than the above: 2,500 VAC, 50/60 Hz for 1 min Between contacts of same polarity: 1,500 VAC, 50/60 Hz for 1 min
Vibration	Destruction	10 to 55 to 10 Hz, 0.75-mm single amplitude (1.5-mm double amplitude)
	Malfunction	10 to 55 to 10 Hz, 0.375-mm single amplitude (0.75-mm double amplitude)
Shock	Destruction	1,000 m/s ²
	Malfunction	100 m/s ²
Durability (See note 7.)	Mechanical	10,000,000 operations min. (at approx. 18,000 operations/hr)
	Electrical	100,000 operations min. (at the rated load and approx. 1,800 operations/hr)
Min. permissible load (See note 8.) (reference value)		5 VDC, 1 mA
Ambient temperature		-25°C to 70°C (with no icing or condensation)
Ambient humidity		5% to 85%
Weight		Approx. 65 g

Note: 1. The values given above are initial values.

- Measurement conditions:
5 VDC, 10 mA, voltage drop method.
- Measurement conditions:
Rated voltage operation
Ambient operating temperature: 23°C
Does not include bounce time.
- Measurement conditions: Measured at the same locations as the dielectric strength with a 500-VDC megohmmeter.
- When using a P7S Socket, the dielectric strength between coil and contacts and between different poles is 2,500 VAC, 50/60 Hz for 1 min.
- The coil refers to terminals 0-1, pole 1 refers to terminals 13-14, pole 2 refers to terminals 23-24, pole 3 refers to terminals 33-34, pole 4 refers to terminals 41-42 or 43-44, pole 5 refers to terminals 51-52, and pole 6 refers to terminals 61-62.

7. The durability is for an ambient temperature of 15°C to 35°C and an ambient humidity of 25% to 75%.

8. The above values are based on an operating frequency of 60 operations/min.

Approved Standards

EN standards approved by VDE:
EN61810-1 (Electromechanical non-specified time all-or-nothing relays)
EN60255-23 (Contact performance)
EN50205 (Relays with forcibly guided (linked) contacts)

UL standards: UL508 (Industrial Control Equipment)

CSA standards: CSA C22.2 No.14 (Industrial Control Equipment)

Dimensions

Note: All units are in millimeters unless otherwise indicated.

Relays with Forcibly Guided Contacts

G7S-4A2B-E
G7S-3A3B-E

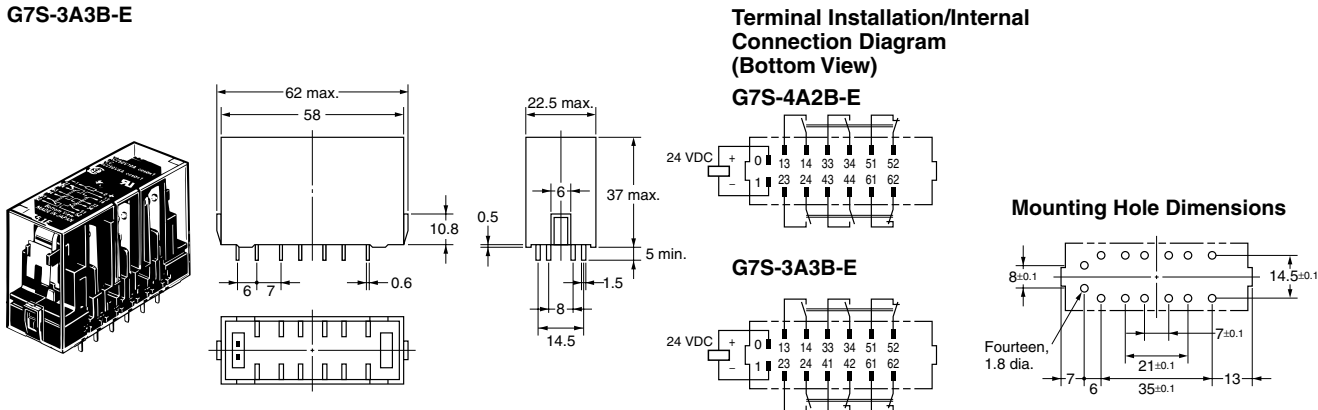

Sockets

P7S-14F-END Track-mounting Socket

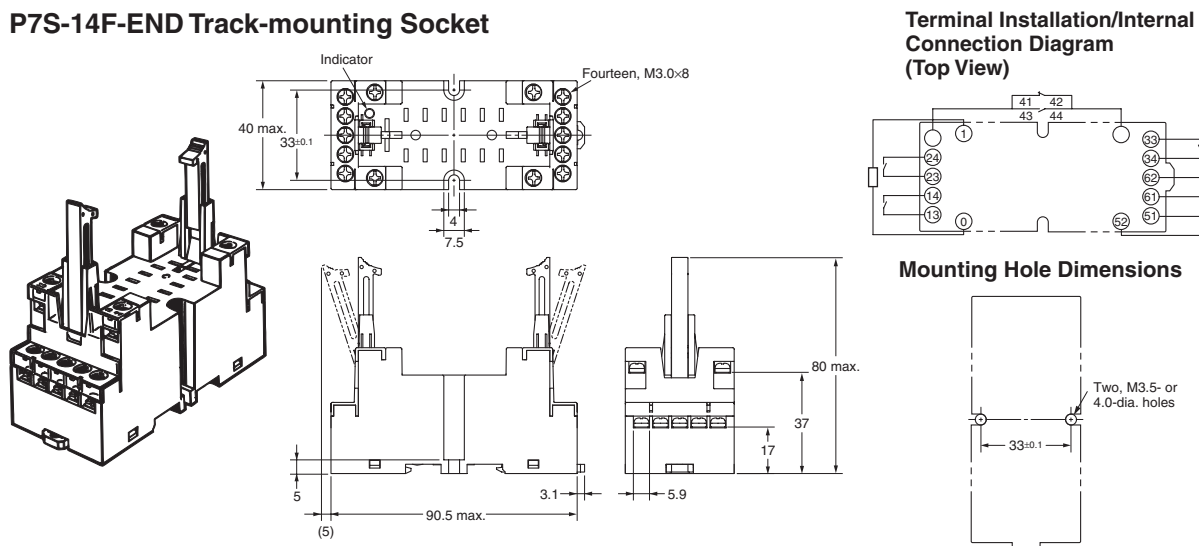

P7S-14P-E Back-mounting Socket (PCB Terminals)

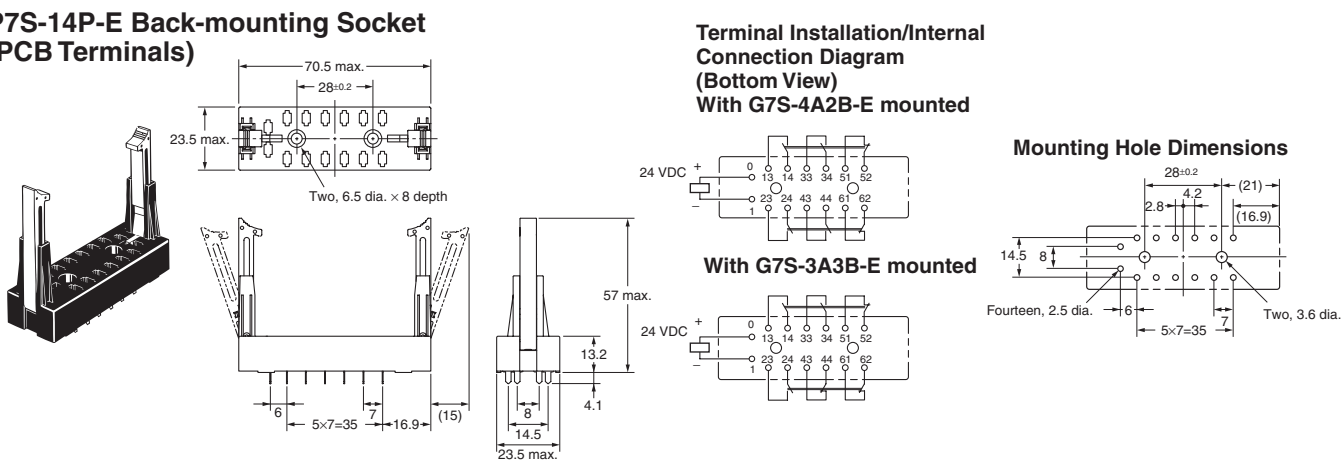

Precautions

⚠ Caution

Do not pass currents of 6 A or more when using this product in combination with the P7S-14F/14P/14A Socket. Doing so may result in fire. Use this product in combination with the P7S-14F-END/14P-E.

Correct Use

Wiring

Use one of the following wires to connect to the P7S-14F-END.

Stranded wire: 0.75 to 1.5 mm²

Solid wire: 1.0 to 1.5 mm²

Tighten each screw of the P7S-14F-END to a torque of 0.98 N·m securely.

Wire the terminals correctly with no mistakes in coil polarity, otherwise the G7S will not operate.

Cleaning

The G7S is not of enclosed construction. Therefore, do not wash the G7S with water or detergent.

Forcibly Guided Contacts (from EN50205)

If an NO contact becomes welded, all NC contacts will maintain a minimum distance of 0.5 mm when the coil is not energized. Likewise if an NC contact becomes welded, all NO contacts will maintain a minimum distance of 0.5 mm when the coil is energized.

Relays with Forcibly Guided Contacts

While the Relay with Forcibly Guided Contacts has the previously described forcibly guided contact structure, it is basically the same as an ordinary relay in other respects. Rather than serving to prevent malfunctions, the forcibly guided contact structure enables another circuit to detect the condition following a contact weld or other malfunction. Accordingly, when a contact weld occurs in a Relay with Forcibly Guided Contacts, depending on the circuit configuration, the power may not be interrupted, leaving the Relay in a potentially dangerous condition (as shown in Fig. 1.)

To configure the power control circuit to interrupt the power when a contact weld or other malfunction occurs, and to prevent restarting until the problem has been eliminated, add another Relay with Forcibly Guided Contacts in combination to provide redundancy and a self-monitoring function to the circuit (as shown in Fig. 2).

The G9S/G9SA Safety Relay Unit, which combines Relays such as the Relay with Forcibly Guided Contacts in order to provide the above-described functions, is available for this purpose. By connecting a contactor with appropriate input and output to the Safety Relay Unit, the circuit can be equipped with redundancy and a self-monitoring function.

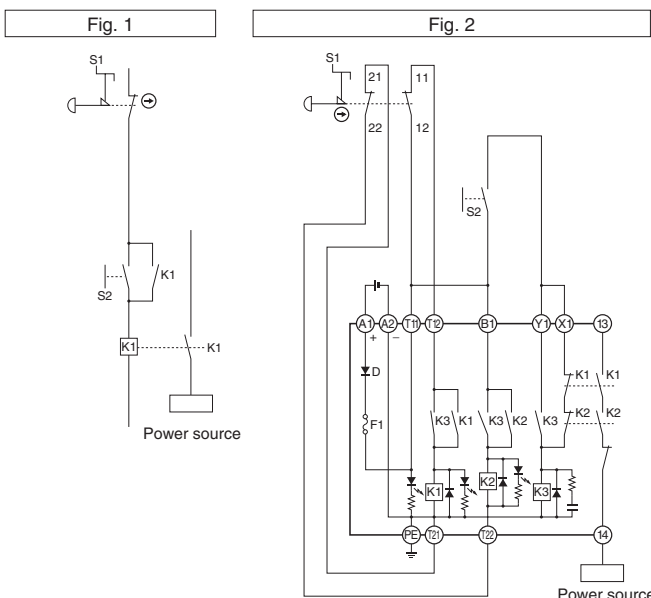

ALL DIMENSIONS SHOWN ARE IN MILLIMETERS.
 To convert millimeters into inches, multiply by 0.03937. To convert grams into ounces, multiply by 0.03527.

Cat. No. J141-E1-01 **In the interest of product improvement, specifications are subject to change without notice.**

OMRON Corporation
 Industrial Automation Company

Measuring and Control Division
 Shiokoji Horikawa, Shimogyo-ku,
 Kyoto, 600-8530 Japan

Tel: (81)75-344-7080/Fax: (81)75-344-7189

Printed in Japan

0303-3M (0303) (B)

AUDIN 8, avenue de la mairie - 91370 Saint Brice Courcelles - Tel : 03.26.04.20.21 - Fax : 03.26.04.28.20 - Web : <http://www.audin.fr> - Email : info@audin.fr