

### DIN 22.5-mm Solid-state Power OFF-delay Timer

- High immunity to inverter noise.
- Long power OFF-delay times;  
S-series: up to 12 seconds,  
L-series: up to 120 seconds.



## Ordering Information

Supply voltage	S-series	L-series
100 to 120 VAC	H3DR-H	H3DR-H
200 to 240 VAC		
24 VAC/DC		
48 VAC/DC		

**Note:** Specify both the model number and supply voltage when ordering.

Example: H3DR-H 24 VAC/DC S

Time span code  
Supply voltage

### Model Number Legend:

H3DR-□  
1

#### 1. Classification

H: Power OFF-delay timer

## Specifications

### ■ General

Item	H3DR-H
Operating mode	Power OFF-delay
Terminal block	5 terminals used
Operating/Reset method	Instantaneous operation/Time-limit reset
Output type	Relay output (SPDT)
Mounting method	DIN track mounting
Approved standards	UL508, CSA C22.2 No.14 Conforms to VDE0435/2021 C/250, VDE0110, VDE0106/P100 Conforms to EN50081-2, prEN50082-2
Attachment	Name plate

### ■ Time Ranges

Time ranges	Setting	Setting range	Min. power ON time
S-series	Time scale: x 0.1	0.1 to 1.2 s	0.1 s min.
	Time scale: x 1	1 to 12 s	
L-series	Time scale: x 1	1 to 12 s	0.3 s min.
	Time scale: x 10	10 to 120 s	

**Note:** If the above minimum power ON time is not secured, the H3DR may not operate. Be sure to secure the above minimum power ON time. Allow at least 3 s for repeat synchronization of **time-out** operations (see *Precautions* on page 7).

## ■ Ratings

<b>Rated supply voltage (see note)</b>	100/110/120 VAC (50/60 Hz), 200/220/240 VAC (50/60 Hz), 24 VAC/DC (50/60 Hz), 48 VAC/DC (50/60 Hz)
<b>Operating voltage range</b>	85% to 110% of rated supply voltage
<b>Power consumption</b>	100/110/120 VAC: approx. 0.5 VA 200/220/240 VAC: approx. 0.8 VA 24 VAC/DC: approx. 0.17 VA (AC), 0.13 W (DC) 48 VAC/DC: approx. 0.36 VA (AC), 0.34 W (DC)
<b>Control outputs</b>	Contact output: 5 A at 250 VAC, resistive load ( $\cos\phi = 1$ )

**Note:** A power supply with a ripple of 20% max. (single-phase power supply with full-wave rectification) can be used with each DC Model.

## ■ Characteristics

<b>Accuracy of operating time</b>	±1% FS max. (1% FS ±10 ms max. in ranges of 1.2 s)
<b>Setting error</b>	±10% FS ±0.05 s max.
<b>Influence of voltage</b>	±0.5% FS max. (±0.5% FS ±10 ms in ranges of 1.2 s)
<b>Influence of temperature</b>	±2% FS max. (±2% FS ±10 ms in ranges of 1.2 s)
<b>Insulation resistance</b>	100 MΩ min. (at 500 VDC)
<b>Dielectric strength</b>	2,000 VAC, 50/60 Hz for 1 min (between current-carrying metal parts and exposed non-current-carrying metal parts) 2,000 VAC, 50/60 Hz for 1 min (between control output terminals and operating circuit) 1,000 VAC, 50/60 Hz for 1 min (between contacts not located next to each other)
<b>Impulse withstand voltage</b>	3 kV (between power terminals) for 100 to 120 VAC, 200 to 240 VAC 1 kV for 24 VAC/DC, 48 VAC/DC 4.5 kV (between current-carrying terminal and exposed non-current-carrying metal parts) for 100 to 120 VAC, 200 to 240 VAC 1.5 kV for 24 VAC/DC, 48 VAC/DC
<b>Noise immunity</b>	±1.5 kV (between power terminals), square-wave noise by noise simulator (pulse width: 100 ns/1 μs, 1-ns rise)
<b>Static immunity</b>	Malfunction: 4 kV Destruction: 8 kV
<b>Vibration resistance</b>	Destruction: 10 to 55 Hz with 0.75-mm single amplitude each in three directions Malfunction: 10 to 55 Hz with 0.5-mm single amplitude each in three directions
<b>Shock resistance</b>	Destruction: 980 m/s <sup>2</sup> (100G) each in three directions Malfunction: 98 m/s <sup>2</sup> (10G) each in three directions
<b>Ambient temperature</b>	Operating: -10°C to 55°C (with no icing) Storage: -25°C to 65°C (with no icing)
<b>Ambient humidity</b>	Operating: 35% to 85%
<b>Life expectancy</b>	Mechanical: 10 million operations min. (under no load at 1,200 operations/h) Electrical: 100,000 operations min. (5 A at 250 VAC, resistive load at 1,200 operations/h)
<b>EMC</b>	Emission Enclosure: EN55011 Group 1 class A Emission AC Mains: EN55011 Group 1 class A Immunity ESD: IEC801-2: 4 kV contact discharge (level 2) 8 kV air discharge (level 3) Immunity RF-interference: ENV50140: 10 V/m (80 MHz to 1 GHz) (level 3) Immunity Conducted Disturbance: ENV50141: 10 V (0.15 to 80 MHz) (level 3) Immunity Burst: IEC801-4: 2 kV power-line (level 3) 2 kV I/O signal-line (level 4)
<b>Enclosure ratings</b>	IEC: IP40
<b>Weight</b>	Approx. 135 g

# Engineering Data

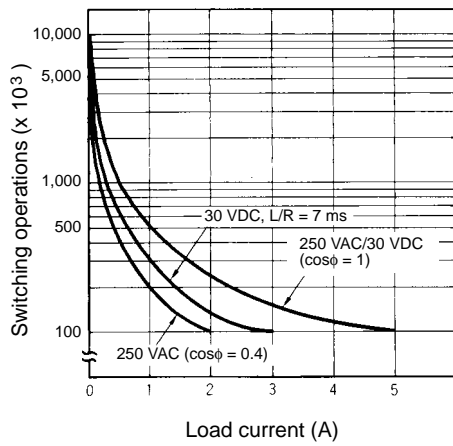

Reference: The minimum applicable load is 100 mA at 5 VDC (failure level: P).

# Nomenclature

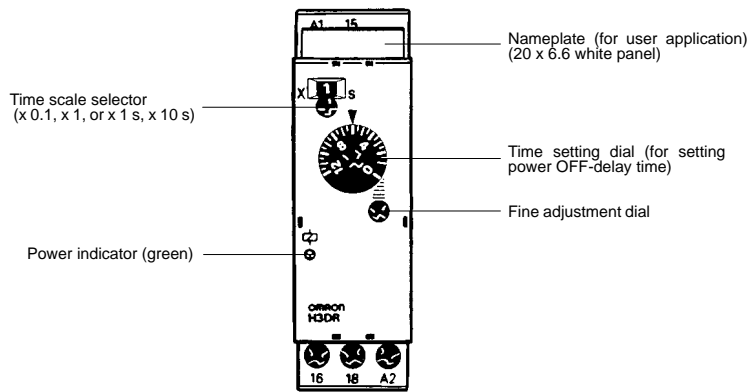

**Note:** The fine adjustment dial affects the setting on the main dial.

# Operation

## Basic Operation

### Time Scale Selection

The scale is selected with the time scale selector at the upper-left corner of the front panel and appears in the window above the selector: 0.1 or 1 for S-series, 1 x 10 for L-series

### Time Setting

Use the main dial to set the operation time. The fine-tuning dial is useful when delicate or more accurate adjustment is required.

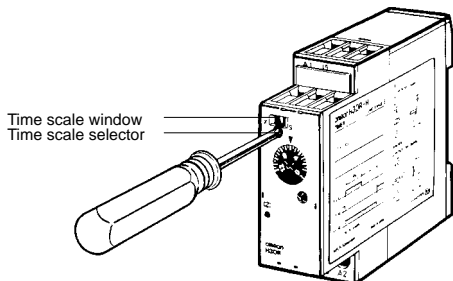

## Block Diagram

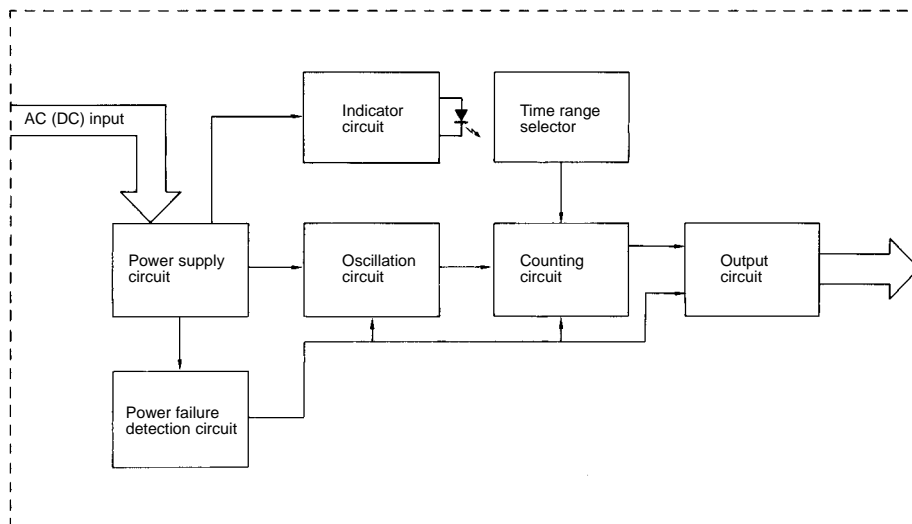

## I/O Functions

<b>Inputs</b>	<b>Reset</b>	Turns off the control output and resets the elapsed time.
<b>Outputs</b>	<b>Control output</b>	Operates instantaneously when the power is turned on and time-limit resets when the set time is up after the power is turned off.

## ■ Timing Chart

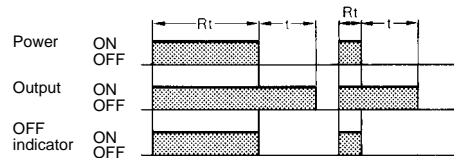

**Note:** t: Set time  
 $R_t$ : Minimum power On time (S-series: 0.1 s min.; L-series: 0.3 s min.)  
 (The output may never turn ON if a value equal to or less than this value is used.)

## Dimensions

**Note:** All units are in millimeters unless otherwise indicated.

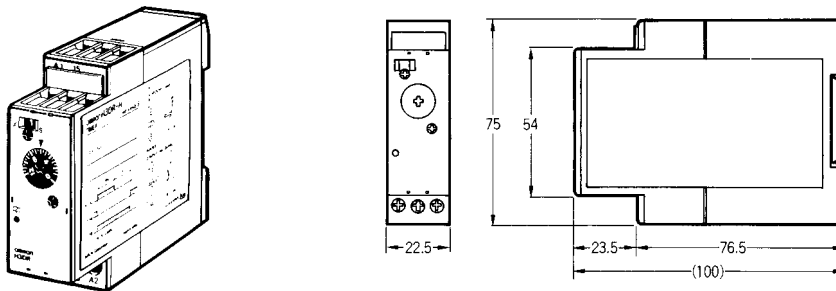

# Installation

## ■ Terminal Arrangement

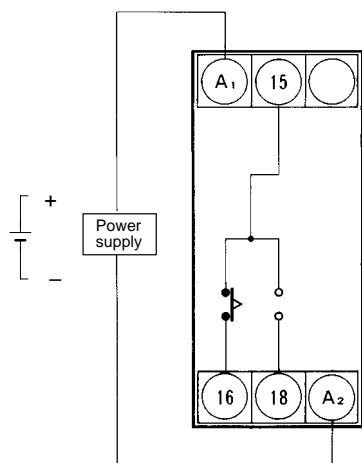

## Dimensions

**Note:** The undermentioned is common for all H3DR-F/G/H models.

**Note:** All units are in millimeters unless otherwise indicated.

## ■ Accessories (Order Separately)

**Mounting Track**  
PFP-100N, PFP-50N

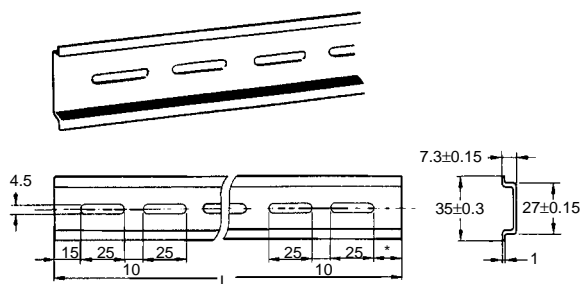

L: Length

1 m	PFP-100N
50 cm	PFP-50N

**End Plate**  
PFP-M

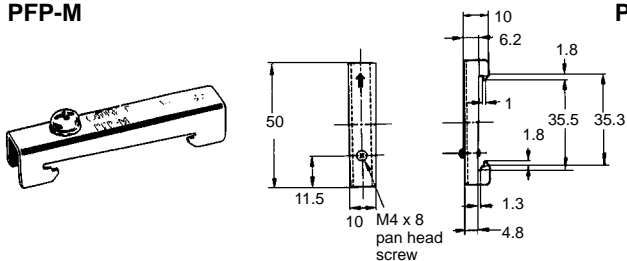

**Spacer**  
PFP-S

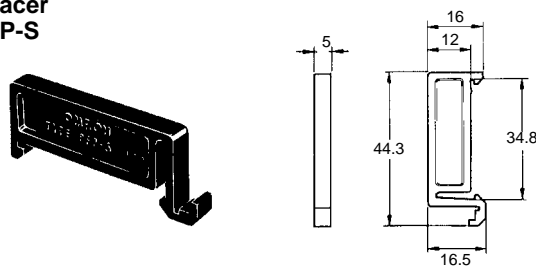

## Precautions

**Note:** The undermentioned is common for all H3DR-F/G/H models.

### ■ Changing of Setting



#### Caution

Do not change the time unit, time range, or operation mode while the timer is in operation or malfunction could result.

### ■ Power Supplies

An AC power supply can be connected to the power input terminals without regarding polarity. A DC power supply must be connected to the power input terminals as designated according to the polarity of the terminals.

A DC power supply can be connected if its ripple factor is 20% or less and the mean voltage is within the rated operating voltage range of the Timer.

Connect the power supply voltage through a relay or switch in such a way that the voltage reaches a fixed value at once or the Timer may not be reset or a timer error could result.

The H3DR-H has a large inrush current; provide sufficient power supply capacity. If the power supply capacity is too small, there may be delays in turning ON the output.

### Inrush Current

Model		Voltage	Applied voltage	Inrush current (peak value)	Time		
H3DR-F		12 VDC	13.2 VDC	50 mA	10 ms max.		
		24 VAC/DC	26.4 VAC	---	10 ms max.		
			26.4 VDC	0.51 A	10 ms max.		
		48 VDC	52.8 VAC	0.79 A	10 ms max.		
		100 to 240 VAC	264 VAC	0.54 A	10 ms max.		
H3DR-G		24 VAC/DC	26.4 VAC	0.79 A	5 ms max.		
			26.4 VDC	0.54 A	10 ms max.		
		48 VDC	52.8 VAC	0.54 A	5 ms max.		
		100 to 240 VAC	264 VAC	0.67 A	5 ms max.		
		H3DR-H	S-series	24 VAC/DC	26.4 VAC	1.28 A	0.15 s max.
26.4 VDC	0.87 A						
48 VAC/DC	52.8 VAC			1.05 A			
	52.8 VDC			0.73 A			
100/110/120 VAC	132 VAC			1.05 A			
200/220/240 VAC	264 VAC			1.00 A			
L-series	24 VAC/DC			26.4 VAC	1.33 A	0.3 s max.	
				26.4 VDC	0.91 A		
	48 VAC/DC		52.8 VAC	1.05 A			
			52.8 VDC	0.73 A			
	100/110/120 VAC		132 VAC	1.05 A			
	200/220/240 VAC		264 VAC	1.01 A			

- Note:**
1. The above figures are all approximations and should be used for reference only.
  2. The inrush current is given mainly for DC models for the required power supply design specifications. For the H3DR-H, the inrush current is also given for 100/110/120-VAC and 200/220/240-VAC models because these models have higher inrush currents than other series.

## ■ Mounting and Dismounting

The H3DR should be mounted as horizontally as possible.

When mounting the H3DR on a socket mounting track, hook portion (A) of the Timer to an edge of the track first, and then depress the Timer in the direction of (B).

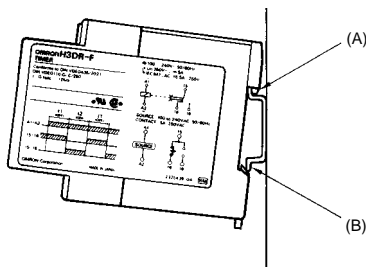

When dismantling the H3DR, pull out portion (C) with a flat-blade screwdriver and remove the Timer from the mounting track.

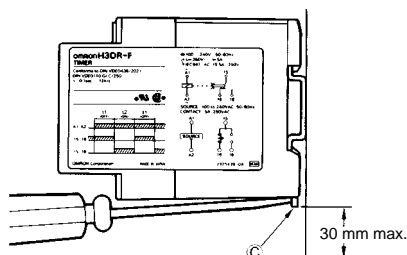

The H3DR can be mounted and dismantled with ease if a distance of 30 mm or more is kept between the H3DR and other equipment.

## ■ Environment

When using the Timer in an area with excess electronic noise, separate the Timer and wiring as far as possible from the noise sources. Organic solvents (such as paint thinner), as well as very acidic or basic solutions can damage the outer casing of the Timer.

## ■ Others

If the Timer is mounted on a control board, dismantle the timer from the control board or short-circuit the circuitry of the power board before carrying out a voltage withstand test between the electric circuitry and non current-carrying metal part of the Timer, in order to prevent the internal circuitry of the Timer from damage.

## ■ Changing Switches

The time unit and time range can be set by turning them either clockwise or counterclockwise.

The switches are designed to click into place. Be sure that the switches are in the proper place and do not leave them between settings. Leaving switches between settings can cause faulty operation.

## ■ Wiring (H3DR-H)

The H3DR has a high impedance circuit. Therefore, the H3DR may not be reset if the H3DR is influenced by inductive voltage. In order to eliminate any influence of inductive voltage, the wires connected to the H3DR must be as short as possible and should not be installed alongside power lines. If the H3DR is influenced by inductive voltage that is 30% or more of the rated voltage, connect a CR filter with a capacitance of approximately 0.1  $\mu\text{F}$  and a resistance of approximately 120  $\Omega$  or a bleeder resistor between the power supply terminals. If there is any residual voltage due to current leakage, connect a bleeder resistor between the power supply terminals.

## ■ Operation (H3DR-H)

An interval of 3 s minimum is required to turn on the H3DR after the H3DR is turned off. If the H3DR is turned on and off repeatedly with an interval of shorter than 3 s, the internal parts of the H3DR may deteriorate and the H3DR may malfunction.

