

### DIN 22.5-mm Solid-state Twin Timers

- High immunity to inverter noise.
- Independent ON- and OFF-time settings. Combinations of long ON- or OFF-time and short OFF- or ON-time settings are possible.
- Seven time ranges from 0.1 s to 12 h.
- Wide AC power supply range: 100 to 240 VAC.



### Ordering Information

Operating modes	Supply voltage	Model
Flicker OFF start	100 to 240 VAC	H3DR-F
	48 VAC	
	24 VAC/DC	
	12 VDC	

**Note:** Specify both the model number and supply voltage when ordering.  
Example: H3DR-F 24 VAC/DC

Supply voltage

### Model Number Legend:

H3DR-□  
1

1. Classification  
F: Twin timers

### Specifications

#### ■ General

Item	H3DR-F
Operating mode	Flicker OFF start
Terminal block	5 terminals used
Operating/Reset method	Time-limit operation/Time-limit reset or self-reset
Output type	Relay output (SPDT)
Mounting method	DIN track mounting
Approved standards	UL508, CSA C22.2 No. 14 Conforms to VDE0435/2021 C/250, VDE0110, VDE0106/P100 Conforms to EN50081-2, prEN50082-2
Attachment	Name plate

#### ■ Time Ranges

Time unit	sec	10 s	min	hrs	
0	Instantaneous (see note)				
Setting	Time scale: x 0.1 s	0.1 to 1.2 s	1 to 12 s	0.1 to 1.2 min	0.1 to 1.2 h
	Time scale: x 1 s	1 to 12 s	10 to 120 s	1 to 12 min	1 to 12 h

**Note:** To obtain instantaneous output, set to below 0.

## ■ Ratings

<b>Rated supply voltage (see note)</b>	100 to 240 VAC (50/60 Hz), 48 VAC (50/60 Hz), 24 VAC/DC (50/60 Hz), 12 VDC
<b>Operating voltage range</b>	85% to 110% of rated supply voltage; 90% to 110% with 12-VDC models
<b>Power reset</b>	Minimum power-opening time: 0.1 s
<b>Power consumption</b>	100 to 240 VAC: approx. 8.2 VA; 48 VAC: approx. 1.7 VA; 24 VAC/DC: approx. 1.3 VA (AC), approx. 0.6 W (DC); 12 VDC: approx. 0.4 W
<b>Control outputs</b>	Contact output: 5 A at 250 VAC, resistive load ( $\cos\phi = 1$ )

**Note:** A power supply with a ripple of 20% max. (single-phase power supply with full-wave rectification) can be used with each DC Model.

## ■ Characteristics

<b>Accuracy of operating time</b>	±1% FS max. (±1% FS ±10 ms max. in ranges of 1.2 s)
<b>Setting error</b>	±10% FS ±0.05 s max.
<b>Reset time</b>	0.1 s max.
<b>Reset voltage</b>	10% max. of rated supply voltage (10 V max. for 100 to 240 VAC)
<b>Influence of voltage</b>	±0.5% FS max. (±0.5% FS ±10 ms in ranges of 1.2 s)
<b>Influence of temperature</b>	±2% FS max. (±2% FS ±10 ms in ranges of 1.2 s)
<b>Insulation resistance</b>	100 MΩ min. (at 500 VDC)
<b>Dielectric strength</b>	2,000 VAC, 50/60 Hz for 1 min (between current-carrying metal parts and exposed non-current-carrying metal parts) 2,000 VAC, 50/60 Hz for 1 min (between control output terminals and operating circuit) 1,000 VAC, 50/60 Hz for 1 min (between contacts not located next to each other)
<b>Impulse withstand voltage</b>	3 kV (between power terminals) for 100 to 240 VAC 1 kV for 12 VDC, 24 VAC/DC, 48 VAC 4.5 kV (between current-carrying terminal and exposed non-current-carrying metal parts) for 100 to 240 VAC 1.5 kV for 12 VDC, 24 VAC/DC, 48 VAC
<b>Noise immunity</b>	±1.5 kV (between power terminals), square-wave noise by noise simulator (pulse width: 100 ns/1 μs, 1-ns rise) ±400 V for 12 VDC
<b>Static immunity</b>	Malfunction: 4 kV Destruction: 8 kV
<b>Vibration resistance</b>	Destruction: 10 to 55 Hz with 0.75-mm single amplitude each in three directions Malfunction: 10 to 55 Hz with 0.5-mm single amplitude each in three directions
<b>Shock resistance</b>	Destruction: 980 m/s <sup>2</sup> (100G) each in three directions Malfunction: 98 m/s <sup>2</sup> (10G) each in three directions
<b>Ambient temperature</b>	Operating: -10°C to 55°C (with no icing) Storage: -25°C to 65°C (with no icing)
<b>Ambient humidity</b>	Operating: 35% to 85%
<b>Humidity class</b>	DIN 40 040: G
<b>Life expectancy</b>	Mechanical: 20 million operations min. (under no load at 1,800 operations/h) Electrical: 100,000 operations min. (5 A at 250 VAC, resistive load at 1,800 operations/h)
<b>EMC</b>	Emission Enclosure: EN55011 Group 1 class A Emission AC Mains: EN55011 Group 1 class A Immunity ESD: IEC801-2: 4 kV contact discharge (level 2) 8 kV air discharge (level 3) Immunity RF-interference: ENV50140: 10 V/m (80 MHz to 1 GHz) (level 3) Immunity Conducted Disturbance: ENV50141: 10 V (0.15 to 80 MHz) (level 3) Immunity Burst: IEC801-4: 2 kV power-line (level 3) 2 kV I/O signal-line (level 4)
<b>Enclosure ratings</b>	IEC: IP40
<b>Weight</b>	Approx. 110 g

**Note:** The reset voltage is the residual voltage allowed from the power supply when returning the Timer to the status that existed prior to operation.

# Engineering Data

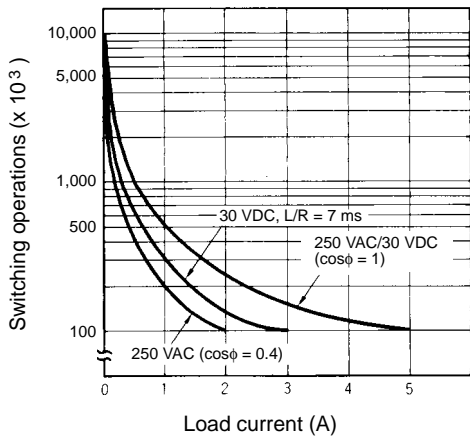

Reference: A maximum current of 0.15 A can be switched at 125 VDC (cosφ = 1) and a maximum current of 0.1 A can be switched if L/R is 7 ms. In both cases, a life of 100,000 operations can be expected. The minimum applicable load is 10 mA at 5 VDC (failure level: P).

# Nomenclature

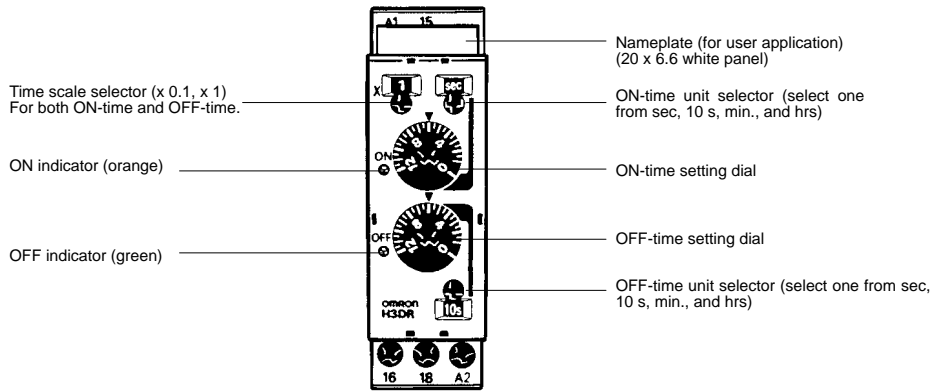

**Note:** The output will change instantly if the setting dial is turned toward 0.

# Operation

## Basic Operation

### Time Unit Selection

For ON-time, the desired time unit (s, 10 s, min, and h) is indicated on the ON-time unit display window at the upper-right corner of the front panel and can be changed by turning the ON-time unit selector located below the window.

For OFF-time, the desired time unit (s, 10 s, min, and h) is indicated on the OFF-time unit display window at the lower-right corner of the front panel and can be changed by turning the OFF-time unit selector located above the window.

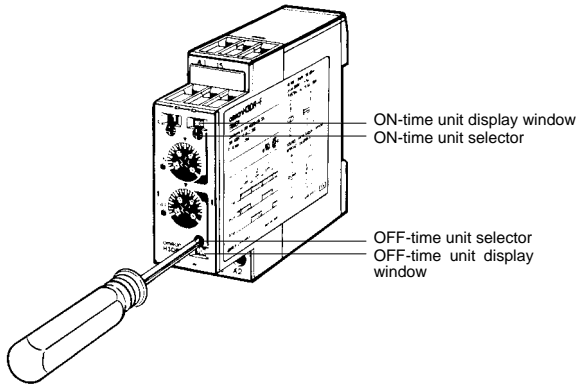

### Time Scale Selection

The scale (0.1 or 1) is selected with the time scale selector at the upper-left corner of the front panel and appears in the window above the selector.

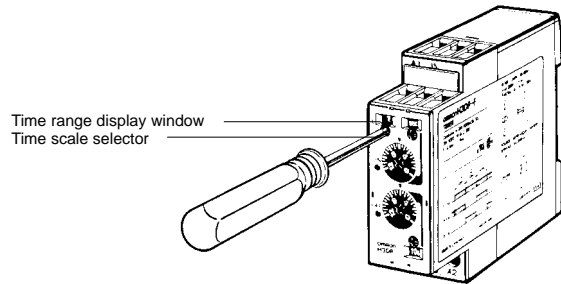

### Time Setting

Use the ON/OFF-time setting dial to set the ON/OFF time.

## Block Diagram

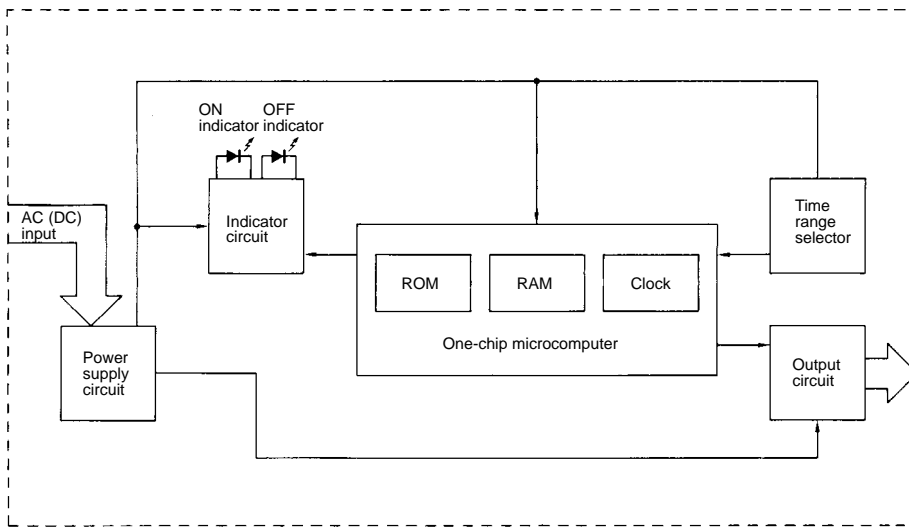

## I/O Functions

Inputs		---
Outputs	Control output	Outputs are turned ON/OFF according to the time set by the ON-and OFF-time setting dial.

■ Timing Chart

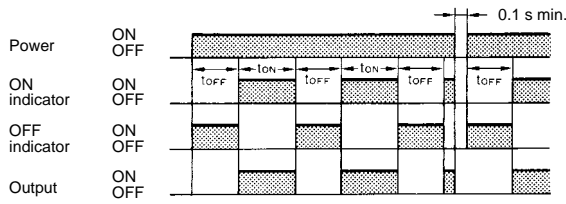

**Note:**  $t_{ON}$ : ON set time  
 $t_{OFF}$ : OFF set time  
 Allow at least 0.1 s for recovery.

Dimensions

**Note:** All units are in millimeters unless otherwise indicated.

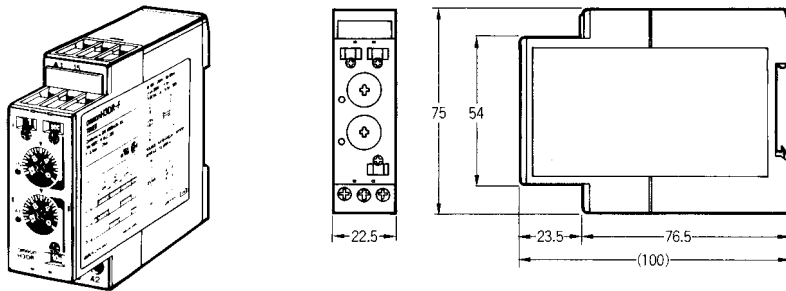

Installation

■ Terminal Arrangement

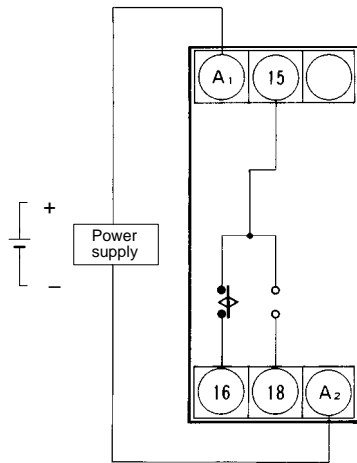

# Dimensions

**Note:** The undermentioned is common for all H3DR-F/G/H models.

**Note:** All units are in millimeters unless otherwise indicated.

## ■ Accessories (Order Separately)

**Mounting Track**  
PFP-100N, PFP-50N

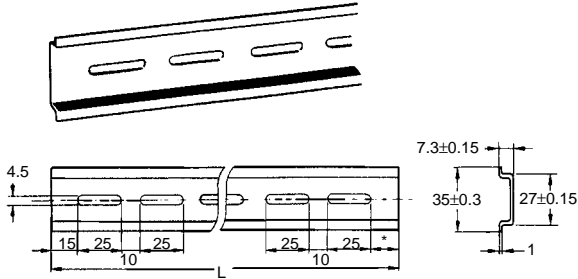

**L: Length**

1 m	PFP-100N
50 cm	PFP-50N

**End Plate**  
PFP-M

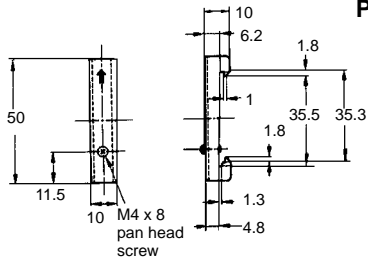
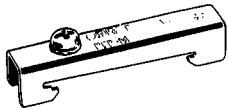

**Spacer**  
PFP-S

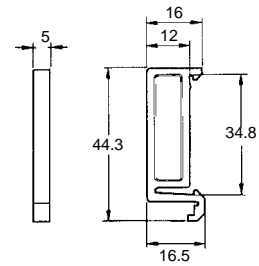
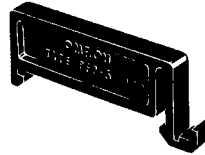

## Precautions

**Note:** The undermentioned is common for all H3DR-F/G/H models.

### ■ Changing of Setting



#### Caution

Do not change the time unit, time range, or operation mode while the timer is in operation or malfunction could result.

### ■ Power Supplies

An AC power supply can be connected to the power input terminals without regarding polarity. A DC power supply must be connected to the power input terminals as designated according to the polarity of the terminals.

A DC power supply can be connected if its ripple factor is 20% or less and the mean voltage is within the rated operating voltage range of the Timer.

Connect the power supply voltage through a relay or switch in such a way that the voltage reaches a fixed value at once or the Timer may not be reset or a timer error could result.

The H3DR-H has a large inrush current; provide sufficient power supply capacity. If the power supply capacity is too small, there may be delays in turning ON the output.

### Inrush Current

Model		Voltage	Applied voltage	Inrush current (peak value)	Time		
H3DR-F		12 VDC	13.2 VDC	50 mA	10 ms max.		
		24 VAC/DC	26.4 VAC	---	10 ms max.		
			26.4 VDC	0.51 A	10 ms max.		
		48 VDC	52.8 VAC	0.79 A	10 ms max.		
		100 to 240 VAC	264 VAC	0.54 A	10 ms max.		
H3DR-G		24 VAC/DC	26.4 VAC	0.79 A	5 ms max.		
			26.4 VDC	0.54 A	10 ms max.		
		48 VDC	52.8 VAC	0.54 A	5 ms max.		
		100 to 240 VAC	264 VAC	0.67 A	5 ms max.		
		H3DR-H	S-series	24 VAC/DC	26.4 VAC	1.28 A	0.15 s max.
26.4 VDC	0.87 A						
48 VAC/DC	52.8 VAC			1.05 A			
	52.8 VDC			0.73 A			
100/110/120 VAC	132 VAC			1.05 A			
200/220/240 VAC	264 VAC			1.00 A			
L-series	24 VAC/DC			26.4 VAC	1.33 A	0.3 s max.	
				26.4 VDC	0.91 A		
	48 VAC/DC		52.8 VAC	1.05 A			
			52.8 VDC	0.73 A			
	100/110/120 VAC		132 VAC	1.05 A			
	200/220/240 VAC		264 VAC	1.01 A			

- Note:**
- The above figures are all approximations and should be used for reference only.
  - The inrush current is given mainly for DC models for the required power supply design specifications. For the H3DR-H, the inrush current is also given for 100/110/120-VAC and 200/220/240-VAC models because these models have higher inrush currents than other series.

## ■ Mounting and Dismounting

The H3DR should be mounted as horizontally as possible.

When mounting the H3DR on a socket mounting track, hook portion (A) of the Timer to an edge of the track first, and then depress the Timer in the direction of (B).

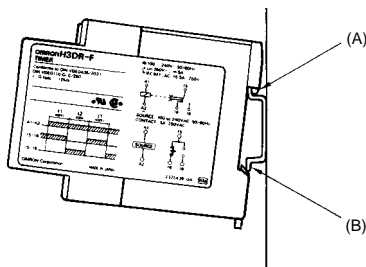

When dismantling the H3DR, pull out portion (C) with a flat-blade screwdriver and remove the Timer from the mounting track.

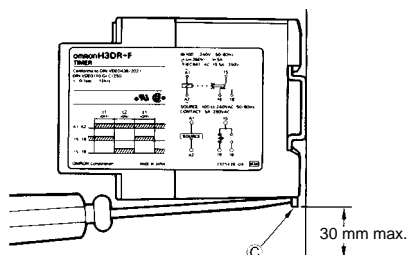

The H3DR can be mounted and dismantled with ease if a distance of 30 mm or more is kept between the H3DR and other equipment.

## ■ Environment

When using the Timer in an area with excess electronic noise, separate the Timer and wiring as far as possible from the noise sources. Organic solvents (such as paint thinner), as well as very acidic or basic solutions can damage the outer casing of the Timer.

## ■ Others

If the Timer is mounted on a control board, dismantle the timer from the control board or short-circuit the circuitry of the power board before carrying out a voltage withstand test between the electric circuitry and non current-carrying metal part of the Timer, in order to prevent the internal circuitry of the Timer from damage.

## ■ Changing Switches

The time unit and time range can be set by turning them either clockwise or counterclockwise.

The switches are designed to click into place. Be sure that the switches are in the proper place and do not leave them between settings. Leaving switches between settings can cause faulty operation.

## ■ Wiring (H3DR-H)

The H3DR has a high impedance circuit. Therefore, the H3DR may not be reset if the H3DR is influenced by inductive voltage. In order to eliminate any influence of inductive voltage, the wires connected to the H3DR must be as short as possible and should not be installed alongside power lines. If the H3DR is influenced by inductive voltage that is 30% or more of the rated voltage, connect a CR filter with a capacitance of approximately 0.1  $\mu\text{F}$  and a resistance of approximately 120  $\Omega$  or a bleeder resistor between the power supply terminals. If there is any residual voltage due to current leakage, connect a bleeder resistor between the power supply terminals.

## ■ Operation (H3DR-H)

An interval of 3 s minimum is required to turn on the H3DR after the H3DR is turned off. If the H3DR is turned on and off repeatedly with an interval of shorter than 3 s, the internal parts of the H3DR may deteriorate and the H3DR may malfunction.

