

Auto Focus Multi Code Reader

V430-F series

Smallest in class *1

- Autofocus to read codes at different distances
- Liquid lens for long life autofocus
- Best in class: 5 Mpix *2

*1. Fixed mount multi code readers with 1.2 Mpix or more.
Based on Omron investigation in March 2018.

*2. Fixed mount multi code reader. Based on Omron investigation in March 2018.





Ordering Information

Code Readers



Appearance	Number of pixels	Field of view*	Reading distance*	Model
	5 million pixels (Color)	Wide View	Autofocus	V430-F000W50C
		Middle View	50 to 300 mm	V430-F000M50C
	1.2 million pixels (Monochrome)	Wide View	Autofocus	V430-F000W12M
		Middle View	50 to 300 mm	V430-F000M12M
		Narrow View	Autofocus 40 to 150 mm	V430-F000N12M
	0.3 million pixels (Monochrome)	Middle View	Fixed Focus 50 mm	V430-F050M03M
			Fixed Focus 81 mm	V430-F081M03M
			Fixed Focus 102 mm	V430-F102M03M

* Refer to *Read Ranges* on p.3 for detail.

Mounting Brackets

Appearance	Type	Model
	L Bracket (It's possible to adjust the angle.)	V430-AM0
	Mounting Block	V430-AM1

Cables

Appearance	Type	Connector	Length	Model
	I/O Cables	Straight	3 m	V430-W8-3M
		Straight	5 m	V430-W8-5M
		Right angle down *1	3 m	V430-W8LD-3M
		Right angle up *1	3 m	V430-W8LU-3M
	Ethernet Cables	Straight	3 m	V430-WE-3M
		Straight	5 m	V430-WE-5M
		Right angle down *1	3 m	V430-WELD-3M
		Right angle up *1	3 m	V430-WELU-3M
	Cordset, M12 12-Pin Socket to DB9 Socket with M12 12-Pin Plug	Straight	3 m	V430-W2-3M

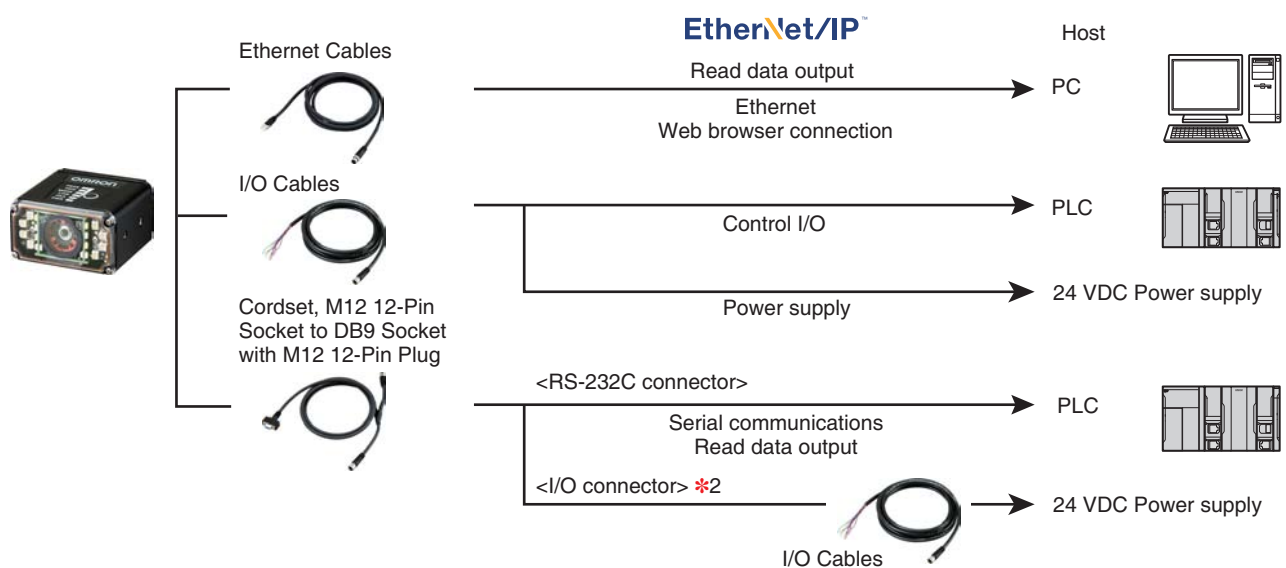

*1. The orientation of connectors are shown below.





Right angle up

Right angle down



*2. Connect V430-W8 to I/O connector (M12 12-pin plug) and connect to a power supply.

Optics Options

Appearance	Type	Model
	Front Window (for replacement)	V430-AF0
	Diffuser	V430-AF1
	Polarizer	V430-AF2
	Right Angle Mirror	V430-AF3

Read Ranges

Read range specifications are subject to change.

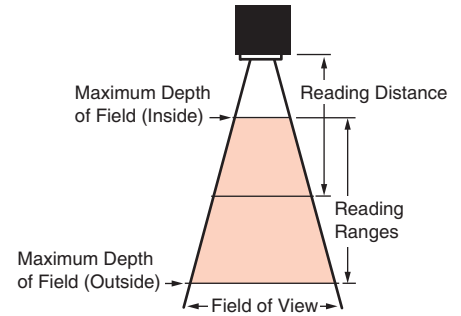

5 million pixels

Wide View

V430-F000W50C

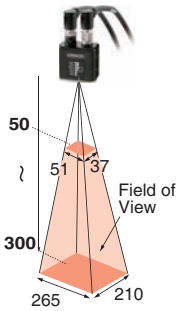

Reading Distance (mm)	Field of View (mm)		Reading Ranges (mm)	
	Horizontal	Vertical	Inside	Outside
50	51	37	43	59
102	96	75	80	124
300	265	210	203	397

Middle View

V430-F000M50C

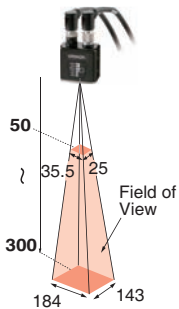

Reading Distance (mm)	Field of View (mm)		Reading Ranges (mm)	
	Horizontal	Vertical	Inside	Outside
50	35.5	25	46.5	54.5
102	66	49	94	110
300	184	143	227	373

1.2 million pixels

Wide View

V430-F000W12M

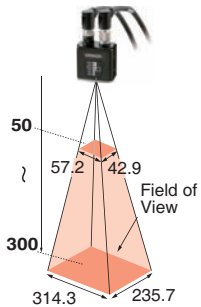

Reading Distance (mm)	Field of View (mm)		Reading Ranges (mm)	
	Horizontal	Vertical	Inside	Outside
50	57.2	42.9	37	64
102	109.5	82.2	74	131
300	314.3	235.7	224	427

V430-F

Middle View

V430-F000M12M

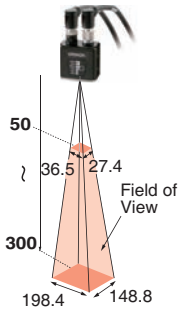

Reading Distance (mm)	Field of View (mm)		Reading Ranges (mm)	
	Horizontal	Vertical	Inside	Outside
50	36.5	27.4	47.5	55
102	71.4	53.6	88	116
300	198.4	148.8	185	400

Narrow View

V430-F000N12M

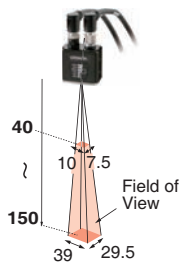

Reading Distance (mm)	Field of View (mm)		Reading Ranges (mm)	
	Horizontal	Vertical	Inside	Outside
40	10.0	7.5	38.5	41.5
81	20.6	15.4	78.5	83.5
150	39.0	29.5	132	153

0.3 million pixels

Middle View

Model	Reading Distance (mm)	Field of View (mm)		Reading Ranges (mm)	
		Horizontal	Vertical	Inside	Outside
V430-F050M03M	50	35	21.5	43	58
V430-F081M03M	81	49	33	65	97
V430-F102M03M	102	65	41	83	121

Minimum 2D Cell Size

The minimum size is what could be read in ideal conditions.

Model	Minimum 2D Cell Size * (mm)	Measurement conditions		
		Reading Distance (mm)	Field of View (mm)	
			Horizontal	Vertical
V430-F000W50C	0.09	50	51	37
V430-F000M50C	0.09	50	35.5	25
V430-F000W12M	0.13	50	57.2	42.9
V430-F000M12M	0.09	50	36.5	27.4
V430-F000N12M	0.05	40	10	7.5
V430-F050M03M	0.13	50	35	21.5
V430-F081M03M	0.19	81	49	33
V430-F102M03M	0.26	102	65	41

* Minimum 1D element is typically 1/2 the size of minimum 2D element.

Ratings and Specifications

Model		V430-F000□50C	V430-F000□12M	V430-F□□□M03M
Applicable codes *1	Bar code	Code 39, Code 128, BC412, ITF (Interleaved 2 of 5), EAN/UPC, Codabar, Code 93, Pharmacode, PLANET, POSTNET, Japanese Post, Australian Post, Royal Mail, Intelligent Mail, KIX, UPU, GS1 Databar (Composite)		
	2D code	DataMatrix (ECC000-ECC200), GS1 DataMatrix, QR Code, Micro QR Code, Aztec Code, DotCode, PDF417, Micro PDF417, GS1 Databar (Stacked)		
Reading performance *2	Number of reading digits	No upper limit (depends on bar width and reading distance)		
	Aiming light	Two Blue LEDs		
	Light source	Inner LEDs: Four White and Four Red LEDs (wave length: 625 nm)		
		Outer LEDs: Eight White LEDs	Outer LEDs: Eight Red LEDs (wave length: 617 nm)	Outer LEDs: Eight Red LEDs (wave length: 617 nm)
	Reading distance/Field of view	Refer to <i>Read Ranges</i> on page 3 for detail.		
	Pitch angle (α)	$\pm 30^\circ$		
	Skew angle (β)	$\pm 30^\circ$		
Tilt angle (γ)	$\pm 180^\circ$			
Image capture device	Effective pixels	2592 (H) x 1944 (V)	1280 (H) x 960 (V)	752 (H) x 480 (V)
	Color/Monochrome	Color CMOS	Monochrome CMOS	Monochrome CMOS
	Shutter Method	Rolling shutter	Global shutter	Global shutter
	Frame Rate	5 fps	42 fps	60 fps
	Shutter Speed	50 us to 100 ms		
Image logging	FTP			
Reading trigger	External trigger (edge, level), Trigger by command (Ethernet, RS-232C)			
I/O specifications	Input signals	Trigger, New Master: 4.5 to 28 V rated (10 mA at 28 VDC)		
	Output signals	Output1, Output2, Output3: 1 to 28 V rated (100 mA Max. at 24 VDC)		
	Communication specification	RS-232C, Ethernet TCP/IP, EtherNet/IP™		
	Ethernet specifications	100BASE-TX/10BASE-T		
Indicator Lamps	PASS (Green), TRIG (Amber), MODE (Amber), LINK (Amber), FAIL (Red), PWR (Green)			
Power voltage	5.0 to 30.0 VDC (including ripple)			
Consumption current	0.18 A (typ.) (at 24 VDC)			
Environmental specifications	Ambient temperature range	Operating: 0 to 40°C, Storage: -50 to +75°C (with no icing or condensation)		
	Ambient humidity range	Operating: 5 to 85%RH, Storage: 5 to 85%RH (with no condensation)		
	Ambient atmosphere	No corrosive gases		
	Vibration Resistance (destruction)	10 to 55 Hz, double amplitude: 0.35 mm, X/Y/Z directions, 10 cycles/axis		
	Shock resistance (destruction)	150 m/s ² , 3 times in each X/Y/Z directions		
	Degree of protection	IEC 60529 IP67		
Weight	Main body only	Approx. 68 g		
	Packing weight	Approx. 174 g (including packing)		
Dimensions	Main body Dimension	44.5 (W) x 44.5 (D) x 25.4 (H) mm		
	Packing Dimension	170 (W) x 117 (D) x 86 (H) mm		
Accessories	Instruction manual ("Read me first"), Compliance Sheet (CE)			
LED class	Risk Group Exempt (IEC 62471-1)			
Safety standards	EN61326-1: 2013 FCC Part 15, Subpart B (Class A) KC CISPR 11, IEC 61000-4-2: 2008 UL60950-1 RCM, EAC			
Material	Case	Aluminum diecast, alumite (black)		
	Reading window	Acrylic		

*1. These are the code types supported based on Omron's read capability validation standard. It is recommended that the customer do its own validation in its actual work environment.

*2. Unless otherwise specified, the reading performance is defined with center of field of view, angle $R=\infty$.

*3.

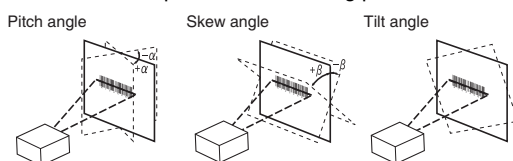

V430-F

Dimensions

(Unit: mm)

Code Readers V430-F

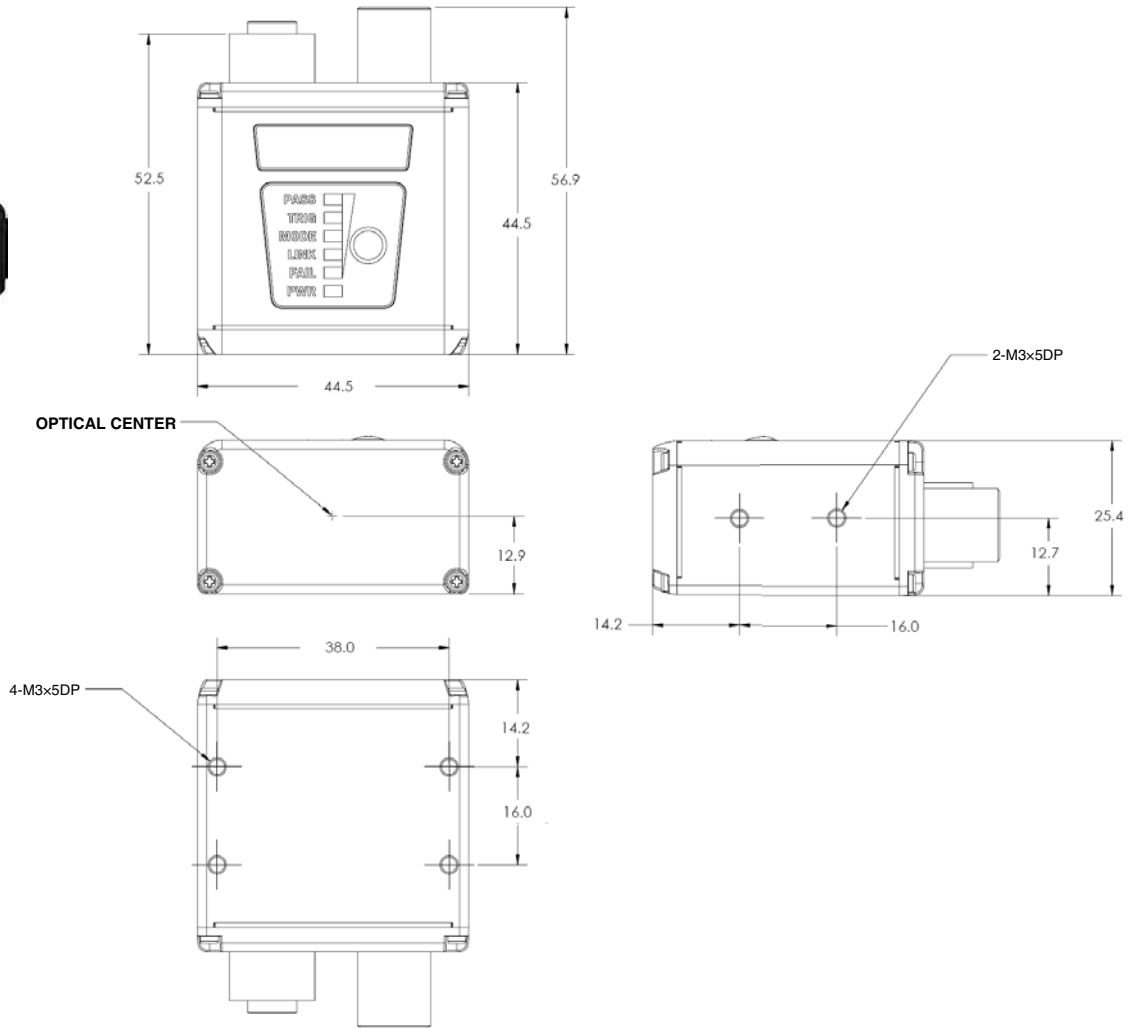

Mounting Brackets

L Bracket V430-AM0

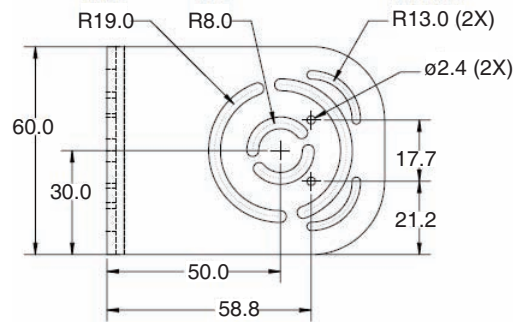

Material: SUS304

Accessories: Phillips-HeadScrews (M3x6) (2)
Washer (2)

The following accessories are not used
with the V430-F Series:

Phillips-Head Screws (M2x6) (2)
Washers for M2 Screws (2)

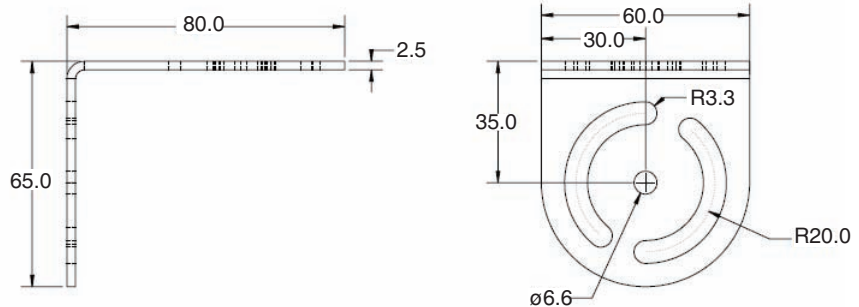

**Mounting Block
V430-AM1**



Material: Aluminum alloy
Accessories: Cap Screws (M3x6) (2)

The following accessories are not used with the V430-F Series:
Cap Screws (M2x8) (2)

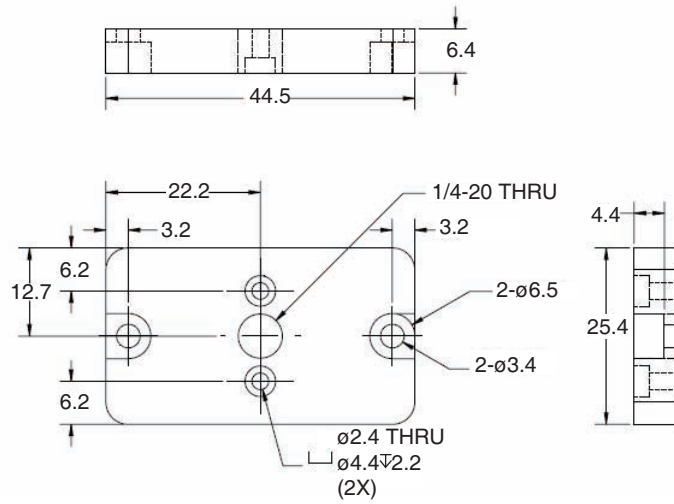

**Right Angle Mirror
V430-AF3**



Material: Bracket: Aluminum
Mirror

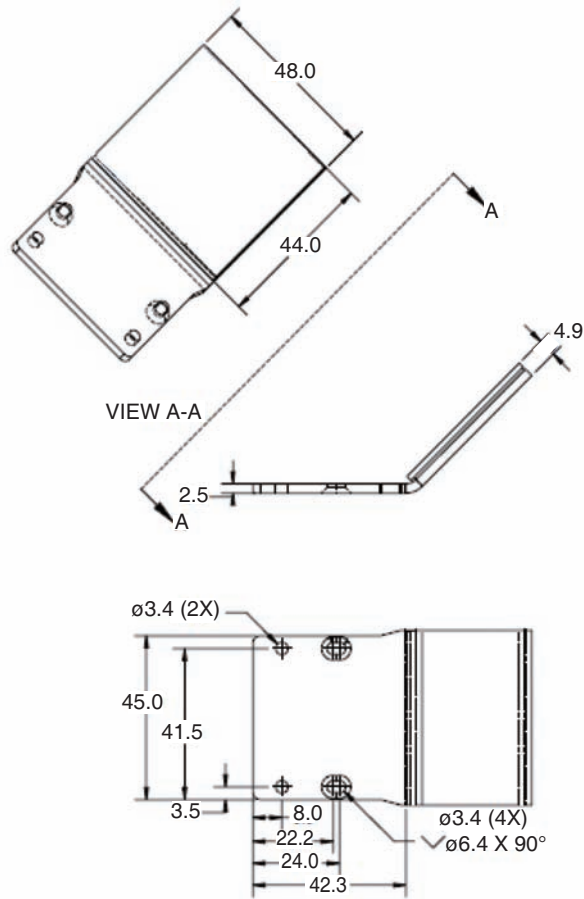

Ethernet Cables

Cordset, M12 8-Pin Plug to RJ45 Ethernet

3 m Straight

V430-WE-3M

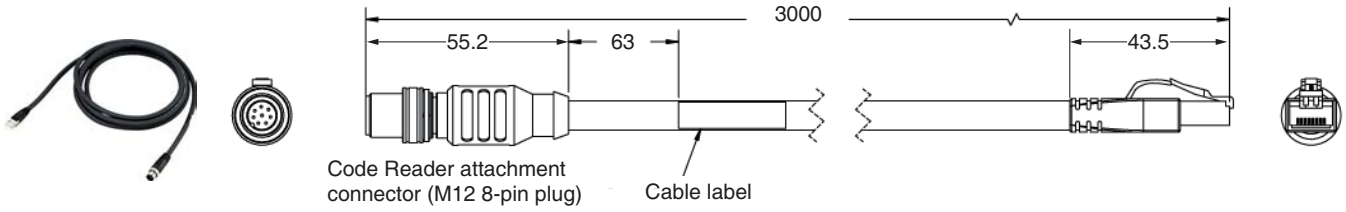

Cordset, M12 8-Pin Plug to RJ45 Ethernet

3 m Right angle down

V430-WELD-3M

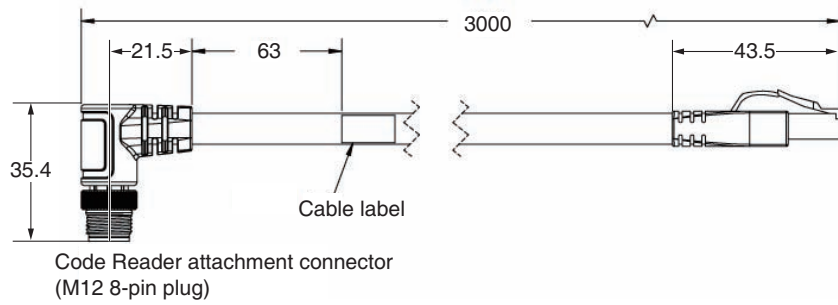

Cordset, M12 8-Pin Plug to RJ45 Ethernet

3 m Right angle up

V430-WELU-3M

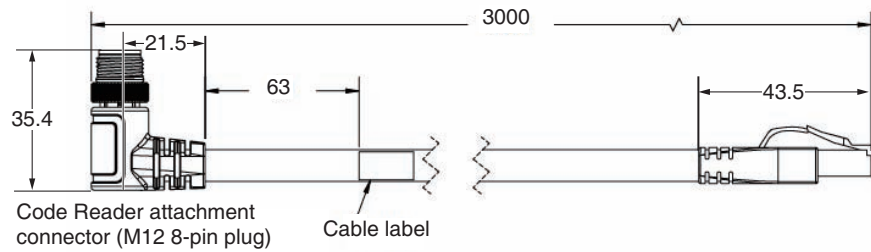

Cordset, M12 8-Pin Plug to RJ45 Ethernet

5 m Straight

V430-WE-5M

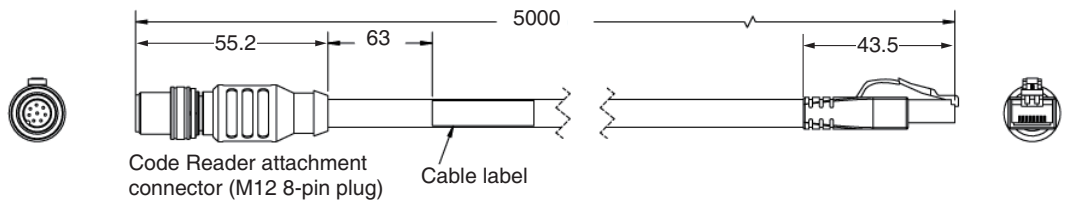

I/O Cables

Cordset, M12 12-Pin Socket to Flying Leads

3 m Straight
V430-W8-3M

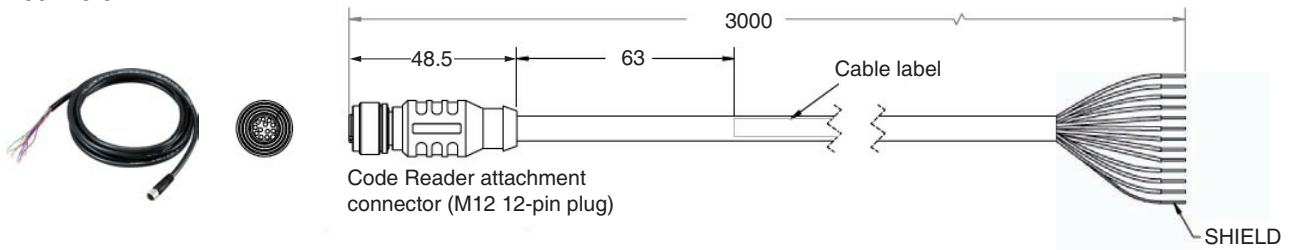

Cordset, M12 12-Pin Socket to Flying Leads

3 m Right angle down
V430-W8LD-3M

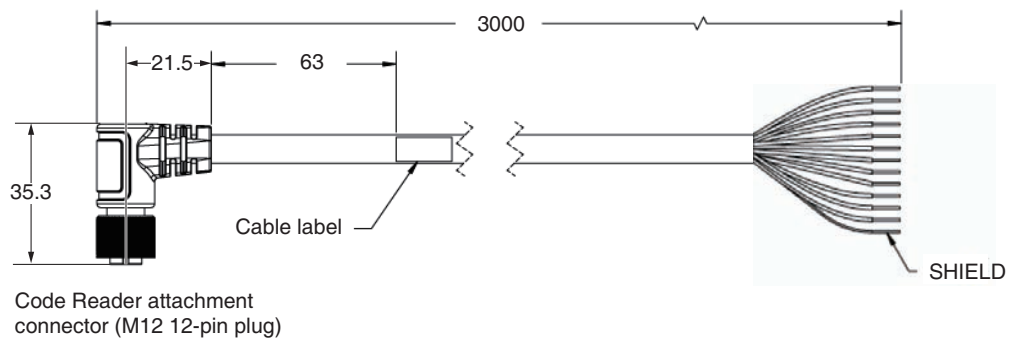

Cordset, M12 12-Pin Socket to Flying Leads

3 m Right angle up

V430-W8LU-3M

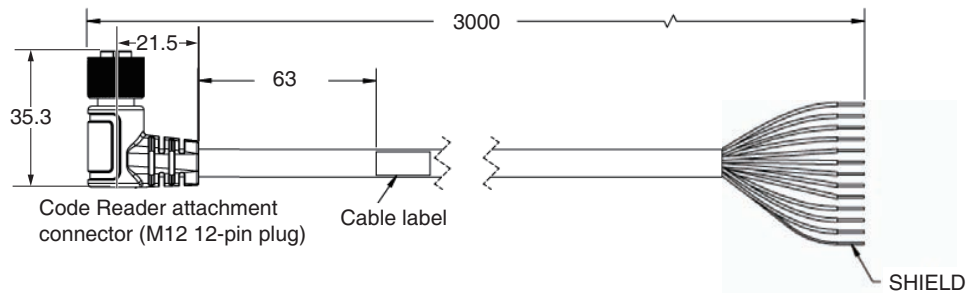

Cordset, M12 12-Pin Socket to Flying Leads

5 m Straight
V430-W8-5M

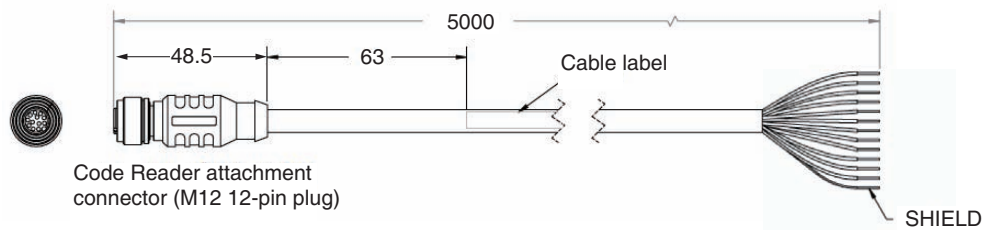

Cordset, M12 12-Pin Socket to DB9 Socket with M12 12-Pin Plug

3 m Straight
V430-W2-3M

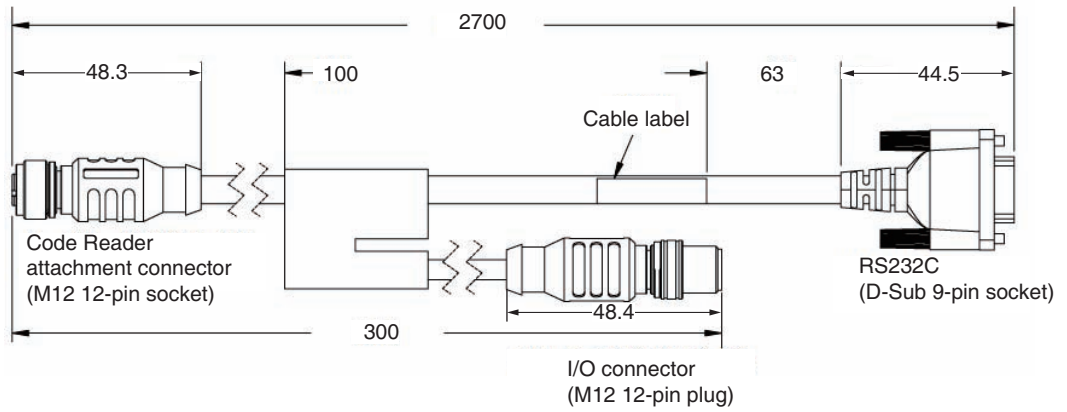

Note: Connect V430-W8 to I/O connector (M12 12-pin plug) and connect to a power supply.

Related Manuals

Man.No.	Model	Manual
Z392	V430	Auto Focus Multi Code Reader V430-F-series User's Manual

Terms and Conditions Agreement

Read and understand this catalog.

Please read and understand this catalog before purchasing the products. Please consult your OMRON representative if you have any questions or comments.

Warranties.

- (a) Exclusive Warranty. Omron's exclusive warranty is that the Products will be free from defects in materials and workmanship for a period of twelve months from the date of sale by Omron (or such other period expressed in writing by Omron). Omron disclaims all other warranties, express or implied.
- (b) Limitations. OMRON MAKES NO WARRANTY OR REPRESENTATION, EXPRESS OR IMPLIED, ABOUT NON-INFRINGEMENT, MERCHANTABILITY OR FITNESS FOR A PARTICULAR PURPOSE OF THE PRODUCTS. BUYER ACKNOWLEDGES THAT IT ALONE HAS DETERMINED THAT THE PRODUCTS WILL SUITABLY MEET THE REQUIREMENTS OF THEIR INTENDED USE.

Omron further disclaims all warranties and responsibility of any type for claims or expenses based on infringement by the Products or otherwise of any intellectual property right. (c) Buyer Remedy. Omron's sole obligation hereunder shall be, at Omron's election, to (i) replace (in the form originally shipped with Buyer responsible for labor charges for removal or replacement thereof) the non-complying Product, (ii) repair the non-complying Product, or (iii) repay or credit Buyer an amount equal to the purchase price of the non-complying Product; provided that in no event shall Omron be responsible for warranty, repair, indemnity or any other claims or expenses regarding the Products unless Omron's analysis confirms that the Products were properly handled, stored, installed and maintained and not subject to contamination, abuse, misuse or inappropriate modification. Return of any Products by Buyer must be approved in writing by Omron before shipment. Omron Companies shall not be liable for the suitability or unsuitability or the results from the use of Products in combination with any electrical or electronic components, circuits, system assemblies or any other materials or substances or environments. Any advice, recommendations or information given orally or in writing, are not to be construed as an amendment or addition to the above warranty.

See <http://www.omron.com/global/> or contact your Omron representative for published information.

Limitation on Liability; Etc.

OMRON COMPANIES SHALL NOT BE LIABLE FOR SPECIAL, INDIRECT, INCIDENTAL, OR CONSEQUENTIAL DAMAGES, LOSS OF PROFITS OR PRODUCTION OR COMMERCIAL LOSS IN ANY WAY CONNECTED WITH THE PRODUCTS, WHETHER SUCH CLAIM IS BASED IN CONTRACT, WARRANTY, NEGLIGENCE OR STRICT LIABILITY.

Further, in no event shall liability of Omron Companies exceed the individual price of the Product on which liability is asserted.

Suitability of Use.

Omron Companies shall not be responsible for conformity with any standards, codes or regulations which apply to the combination of the Product in the Buyer's application or use of the Product. At Buyer's request, Omron will provide applicable third party certification documents identifying ratings and limitations of use which apply to the Product. This information by itself is not sufficient for a complete determination of the suitability of the Product in combination with the end product, machine, system, or other application or use. Buyer shall be solely responsible for determining appropriateness of the particular Product with respect to Buyer's application, product or system. Buyer shall take application responsibility in all cases.

NEVER USE THE PRODUCT FOR AN APPLICATION INVOLVING SERIOUS RISK TO LIFE OR PROPERTY OR IN LARGE QUANTITIES WITHOUT ENSURING THAT THE SYSTEM AS A WHOLE HAS BEEN DESIGNED TO ADDRESS THE RISKS, AND THAT THE OMRON PRODUCT(S) IS PROPERLY RATED AND INSTALLED FOR THE INTENDED USE WITHIN THE OVERALL EQUIPMENT OR SYSTEM.

Programmable Products.

Omron Companies shall not be responsible for the user's programming of a programmable Product, or any consequence thereof.

Performance Data.

Data presented in Omron Company websites, catalogs and other materials is provided as a guide for the user in determining suitability and does not constitute a warranty. It may represent the result of Omron's test conditions, and the user must correlate it to actual application requirements. Actual performance is subject to the Omron's Warranty and Limitations of Liability.

Change in Specifications.

Product specifications and accessories may be changed at any time based on improvements and other reasons. It is our practice to change part numbers when published ratings or features are changed, or when significant construction changes are made. However, some specifications of the Product may be changed without any notice. When in doubt, special part numbers may be assigned to fix or establish key specifications for your application. Please consult with your Omron's representative at any time to confirm actual specifications of purchased Product.

Errors and Omissions.

Information presented by Omron Companies has been checked and is believed to be accurate; however, no responsibility is assumed for clerical, typographical or proofreading errors or omissions.

- EtherNet/IP™ is a trademark of ODVA.
- QR code is the registered trademark of DENSO WAVE.
- Other company names and product names in this document are the trademarks or registered trademarks of their respective companies.
- The product photographs and figures that are used in this catalog may vary somewhat from the actual products.

Note: Do not use this document to operate the Unit.

OMRON Corporation Industrial Automation Company
Kyoto, JAPAN

Contact: www.ia.omron.com

Regional Headquarters

OMRON EUROPE B.V.

Wegalaan 67-69, 2132 JD Hoofddorp
The Netherlands
Tel: (31)2356-81-300/Fax: (31)2356-81-388

OMRON ELECTRONICS LLC

2895 Greenspoint Parkway, Suite 200
Hoffman Estates, IL 60169 U.S.A.
Tel: (1) 847-843-7900/Fax: (1) 847-843-7787

OMRON ASIA PACIFIC PTE. LTD.

No. 438A Alexandra Road # 05-05/08 (Lobby 2),
Alexandra Technopark,
Singapore 119967
Tel: (65) 6835-3011/Fax: (65) 6835-2711

OMRON (CHINA) CO., LTD.

Room 2211, Bank of China Tower,
200 Yin Cheng Zhong Road,
PuDong New Area, Shanghai, 200120, China
Tel: (86) 21-5037-2222/Fax: (86) 21-5037-2200

Authorized Distributor:

© OMRON Corporation 2018 All Rights Reserved.
In the interest of product improvement,
specifications are subject to change without notice.

CSM_3_4_1118
Cat. No. Q258-E1-03

1018(0318)