

FA Wireless SS Terminals WT30

Construct a Wireless System for ON/OFF Data Collection That Is Ideal for Monitoring Production Site Equipment



- Wireless Slave Station equipped with I/O.
- Height of 90 mm and DIN Rail mounting enables installation in control panels.
- Easily check wireless communications status from indicator display.
- I/O Slave Stations can also be used as Slave Stations in WD30 systems.
- Conforms to radio wave standards for Japan, China (pending), USA, and Europe.



Ordering Information

List of Models

Wireless Unit model	Type	Specifications/No. of I/O points
WT30-M01-FLK	Serial master	RS-232C
WT30-SID16	I/O slaves	16 DC inputs (NPN/PNP)
WT30-SMD16		8 DC inputs (NPN/PNP) + 8 transistor outputs (NPN)
WT30-SMD16-1		8 DC inputs (NPN/PNP) + 8 transistor outputs (PNP)

Note: An Antenna and Mounting Brackets are not included with the Wireless SS Terminal.

Accessories

Antennas

Model	Type
WT30-AT001	Magnet-base Antenna (2 antennas per set)
WT30-AT002	Flat Diversity Antenna (1 antenna)
WT30-AT003	Pencil Antenna (2 antennas per set)

Communications Cables

Model	Length	Application
XW2Z-0100U-3	1 m	For personal computer
XW2Z-0200U-3	2 m	
XW2Z-0500U-3	5 m	
XW2Z-0200U-5	2 m	Cross cable for PLC
XW2Z-0500U-5	5 m	

Other

Model	Type
WT30-FT001	DIN Rail Mounting Bracket (for TH35-7.5)
WT30-FT002	DIN Rail Mounting Bracket (for TH35-15)
WT30-FT003	Surface Mounting Bracket (screw-mounting) (2 brackets per set)
WT30-FT011	Flat Diversity Antenna Mounting Brackets (with magnets)
WT30-CA2M	Antenna Extension Cable (1 cable, 2 m)

Applicable Standards

- FCC part 15.247 (USA)
- EN 300 440-2 (Europe)
- ARIB STD-T66 (Japan)
- 信部無[2002] 353号 (China) (approval pending)

Conformity to Safety Standards

Always use a Class 2 power supply to conform to UL standards.

Main Class 2 Power Supplies

OMRON Switching Power Supplies

- S8VS (15 W, 30 W, 60 W type)
- S82K (15 W, 30 W, 50 W, 90 W type)

Conformity to EN Standards

Use a DC power line less than 3 m to conform to EN standards. If a power line of 3 m or longer is required, extend the length at the Switching Power Supply's primary side (i.e., the AC power line).

Applicable Countries

Wireless standards have been met for the following countries. The product cannot be used in any other countries.

Austria, Belgium, Cyprus, Czech Republic, Denmark, Estonia, Finland, France, Germany, Greece, Hungary, Iceland, Ireland, Italy, Japan, Latvia, Lithuania, Luxembourg, Malta, Netherlands, Norway, Poland, Portugal, Slovakia, Slovenia, Spain, Sweden, Switzerland, UK, USA

Specifications

■ Ratings

Item		WT30-M01-FLK Serial Master	WT30-SID16/SMD16/SMD16-1 I/O Slaves
Power supply (wireless communications power supply)	Rated voltage	24 V DC	
	Allowable voltage range	20.4 to 26.4 V DC	
	Power consumption	3 W max. (See note 1.)	
Error output/output power supply (for output circuits)	Rated voltage	---	24 V DC
	Allowable voltage range	---	20.4 to 26.4 V DC
Insulation resistance		20 MΩ min. (at 100 V DC) between the power supply and chassis	20 MΩ min. (at 100 V DC) between the power supply and all I/O and I/O power supply and between the power supply and chassis
Dielectric strength		1,500 V AC for 1 min between power supply and chassis	1,500 V AC for 1 min between the power supply and all I/O and I/O power supply and between the power supply and chassis
Noise immunity		IEC61000-4-4. 1 kV (power supply line)	
Vibration resistance (See note 2.)		JIS C0040 Frequency: 10 to 55 Hz; Amplitude of 0.35 mm or acceleration of 50 m/s ² , whichever is smaller (DIN Rail mounting: single amplitude of 0.1 mm or acceleration of 15 m/s ²) 10 sweeps of 8 min each (i.e., 80 min in total) in X, Y, Z directions	
Shock resistance		Conforms to JIS C0041: 300 m/s ² 3 times each in X, Y, and Z directions	
Ambient operating temperature		-10 to 55°C (with no condensation or icing) (with the Terminal mounted with the dust-proof label facing up)	Number of simultaneously ON I/O points 10 max.: -10 to 55°C (with no condensation or icing) 16 max.: -10 to 50°C (with no condensation or icing) (with the Terminal mounted with the dust-proof label facing up)
Ambient operating humidity		25% to 85% (with no condensation or icing)	
Ambient environment		No corrosive gases	
Storage temperature		-25 to 65°C (with no condensation or icing)	
Protective structure		IP20	
Terminal construction	Power supply and I/O	Screwless terminal block (Phoenix Contact FFKDS/V1-5.08 or equivalent)	
	Serial	D-sub, 9-pin (female) Inch screws (OMRON XM2F-0910-132 or equivalent), Master station only	---
Safety standards		UL: UL508 (Listing)	
Weight		330 g max.	

Note: 1. Provide a power supply of at least 15 W, considering the inrush current generated at startup.

2. Use the WT30-FT003 Surface Mounting Bracket when installing the WT30 in environments subject to vibration.

■ Wireless Interface Specifications

Item	Specifications
Wave type	Spread Spectrum (direct sequence; DS-SS)
Communication method	Simplex
Frequency band	2,401 to 2,480.2 MHz
Number of channels	67 channels (based on switching)
Transmitter output power	10 mW/MHz
Baud rate between wireless stations	100 kbps
Communications distance (See note.)	Indoors: 60 m min. (approx. 50 m min. with Magnet-base Antennas and Flat Diversity Antennas) Outdoors: Approx. 300 m min. (anticipated distances) (without using relay stations)
Error detection method	CRC-CCITT (16 bits)
Relay functions	One stage using I/O slave for the serial master configuration.
Number of stations per area (See note.)	10 sets max. (recommended)
Number of I/O Slaves connected	64 max.

Note: Varies according to the installation environment.

■ Package Contents

- WT30 FA Wireless SS Terminal
- Terminal labels (I/O Slaves only)
- Instruction Sheet
- Adhesive non-slip feet (Serial Master only)

Nomenclature

Serial Master Station

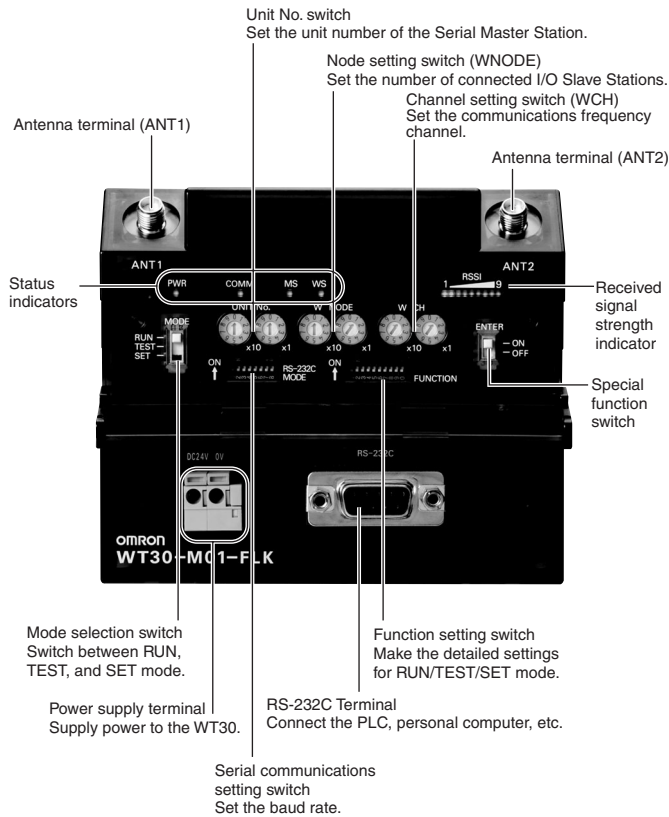

I/O Slave Station

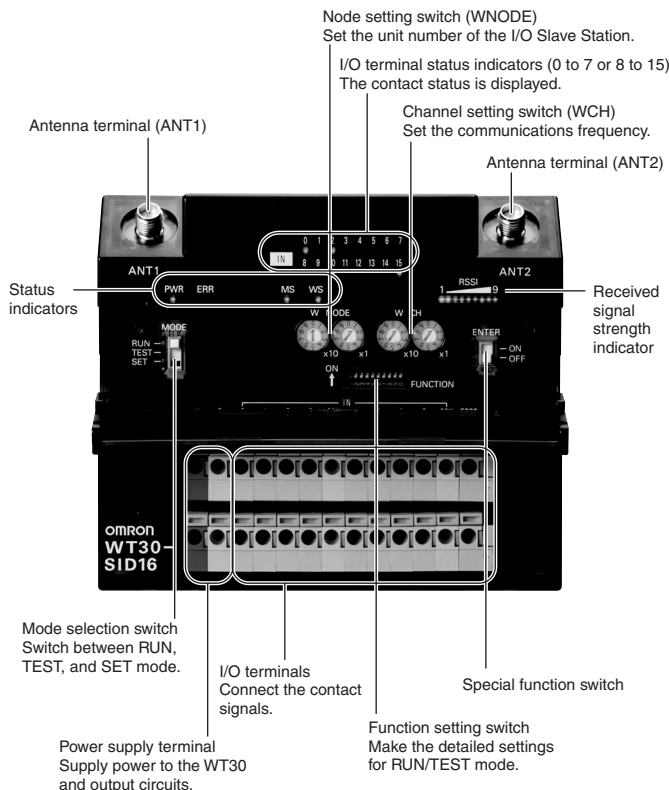

Unit No. Switch

Set the unit number of the Serial Master Station

Default: 00

Node Setting Switch (WNODE)

Set the number of connected I/O Slave Stations.
Set the node number of the Slave Stations being used as I/O Slave Stations. The Slave Station functions as a relay station when the node number is set to 99.

Default: 01

Channel Setting Switch (WCH)

Set the communications frequency.

Default: 02

Function Setting Switch

Serial Master Station

No.	Applicable mode	ON functions	OFF functions
1	RUN mode	Holds I/O status data when a communications error occurs.	Clears I/O status data when a communications error occurs.
2		Enable scan list	Disable scan list
3		Relays used	Relays not used
4	TEST mode	Signal strength monitor disabled	Signal strength monitor enabled
5		All channels automatically switched	Specified channels
6		---	---
7	SET mode	Scan list recognition	Nothing done
8		Registers specified I/O slave	Registers all I/O slaves automatically
9		Recognizes serial numbers	Ignores serial numbers
10	Not used	---	---

I/O Slave Station

No.	Applicable mode	ON functions	OFF functions
1	RUN mode	Holds I/O status data when a communications error occurs.	Clears I/O status data when a communications error occurs.
2		Input hold	Normal mode
3		Input filter: 100 ms	Input filter: 10 ms
4	TEST mode	Signal strength monitor disabled	Signal strength monitor enabled
5		All channels automatically switched	Specified channels
6		Installation test function	Nothing done
7 to 10	Not used	---	---

Serial Communications Setting Switch

No.	Function	ON	OFF
1	Communications setting selection	Detailed settings (settings for No. 2 to 8 used)	Default settings (baud rate: 9,600 bps; data length: 7 bits; parity: even; stop bits: 2) Settings for No. 2 to 8 are ignored.
2	Baud rate (bps)	1	0
3	(See note.)	2	0
4	Total value = 0: 1,200 = 1: 2,400 = 2: 4,800 = 3: 9,600 = 4: 19,200 = 5: 38,400 = 6: 57,600 = 7: 115,200	4	0
5	Data length	8 bits	7 bits
6	Parity	None	Yes
7		Odd	Even
8	Stop bits	1 bit	2 bits

Note: For example, if pins number 2, 3, and 4 are all ON, the total is 7, which corresponds to a baud rate of 115,200 bps.

Display

Indicator	Color	Status	Meaning (primary error)
PWR	Green	Lit	Power is being supplied.
		Not lit	Power is not being supplied.
ERR (Slave Station)	Red	Lit	Error output is ON: Wireless device error or wireless communications error. (See note)
		Not lit	No wireless device error or wireless communications error.
COMM (Master Station)	Yellow	Lit	Serial communications in progress.
		Not lit	No serial communications.
0 to 15 (Slave Station)	Yellow	Lit/Not lit	ON/OFF status for input or output signals
RSSI	Red/ Yellow/ Green	Lit/ All not lit	Receiving Signal Strength Indicator monitor: Number of indicators lit (receiving signal strength 1 to 9) Receiving signal strength less than 0 to 1.
MS (Module Status)	Green	Lit	Communications are normal.
		Flashing	TEST mode or SET mode has been activated.
	Red	Lit	A fatal error has occurred that cannot be recovered from. Replace the Unit
		Flashing	A non-fatal error has occurred that can be recovered from by resetting the system.
	---	Not lit	Power is not being supplied or the system is resetting.
WS (Wireless Status)	Green	Lit	The station has joined the wireless network.
		Flashing	Permission to join wireless network received from Serial Master Station (Slave Station)
	Red	Lit	A fatal error has occurred that cannot be recovered from.
		Flashing	Error from which recovery is possible
	---	Not lit	Wireless communications are not in progress.

Note: When using the WD30 as the Serial Master Station, the ERR indicator will light if normal I/O communications are not possible due to an error in the host network.

Wiring

Serial Master Station (WT30-M01-FLK)

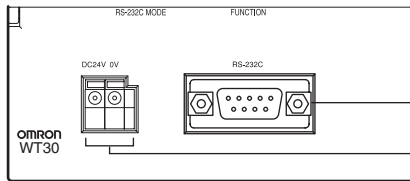

RS-232C Connector

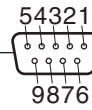

Power supply terminal
Supply power to the Unit

D-sub, 9-pin, Female End at WT30

Pin No.	Signal	I/O direction
1	---	---
2	RD	Output
3	SD	Input
4	---	---
5	SG	---
6	---	---
7	---	---
8	---	---
9	---	---

I/O Characteristics

I/O Slave Station

WT30-SID16

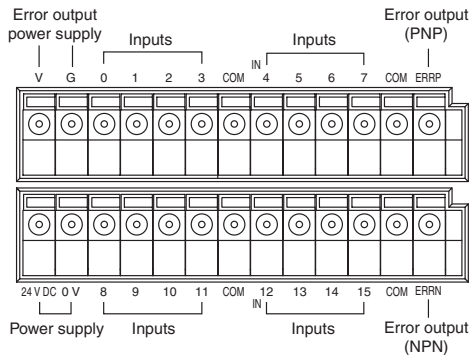

WT30-SMD16

WT30-SMD-16-1

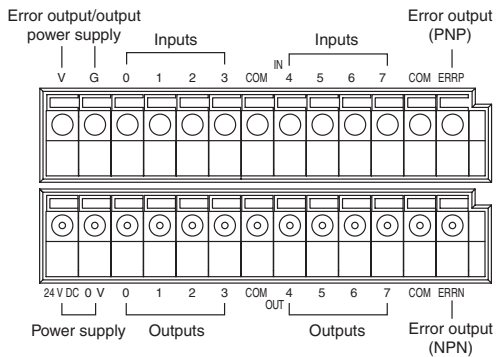

	Item	Specifications
Input Characteristics	Input voltage	24 V DC
	Allowable voltage range	20.4 to 26.4 V DC
	Input impedance	4.7 kΩ (typical)
	Input current	5 mA (typical)
	ON voltage/current characteristics	17.4 V DC, 3.0 mA min.
	OFF voltage/current characteristics	5.0 V DC, 1.0 mA max.
	Input filter	10 ms/100 ms (Selected using switch.)
Output/Error Output Characteristics	Input voltage	24 V DC
	Allowable voltage	20.4 to 26.4 V DC
	Max. switching current	100 mA max. per output (at 20.4 to 26.4 V DC) Simultaneous usage of error output NPN/PNP is not possible.
	Leakage current	0.1 mA max.
	Residual voltage	1.0 V max.
	Fuse	One for every two outputs except for error output circuits, which have one for every NPN/ PNP output. (No fuses can be replaced by the user.)

Input Circuit Diagram

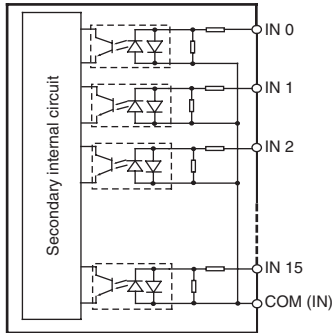

Output Circuit Diagram (NPN)

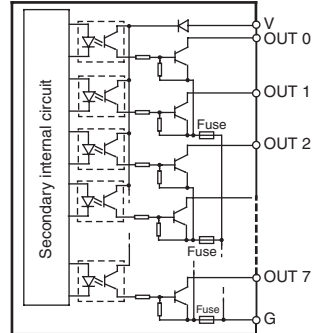

Error Output Circuit Diagram

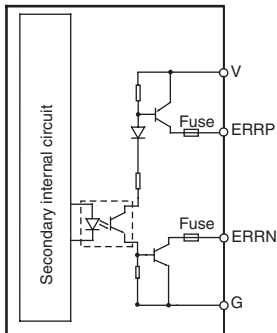

Output Circuit Diagram (PNP)

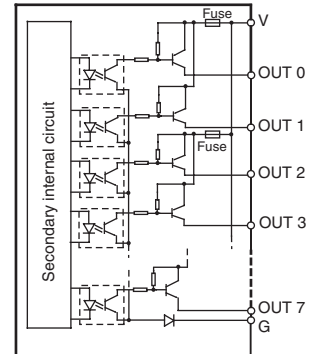

Dimensions

Note: All units are in millimeters unless otherwise indicated.

Serial Master Station

WT30-M01-FLK

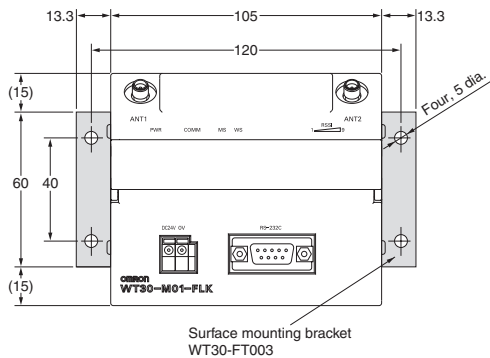

I/O Slave Station

WT30-SID16 WT30-SMD16 WT30-SMD16-1

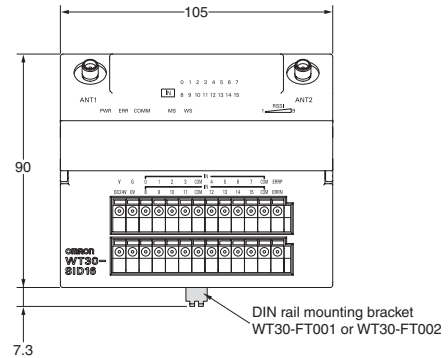

With Magnet-base Antenna

WT30-AT001

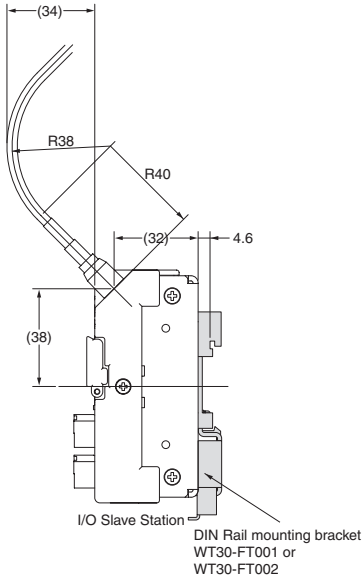

With Flat Diversity Antenna

WT30-AT002

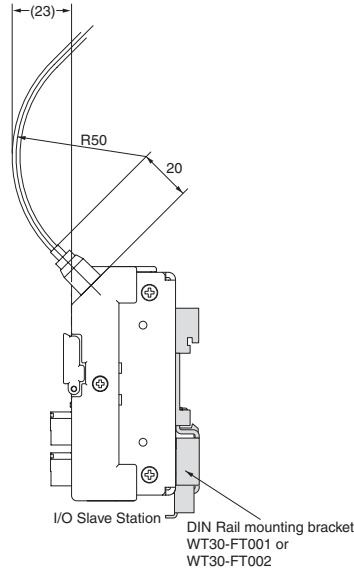

With Pencil Antenna

WT30-AT003

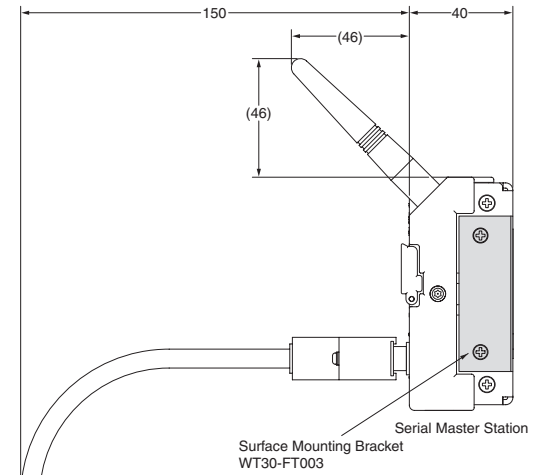

Magnet-base Antenna

WT30-AT001

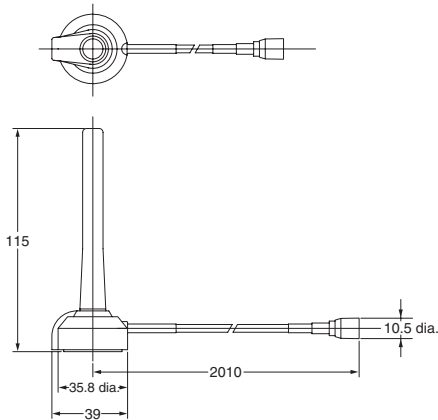

Flat Diversity Antenna

WT30-AT002

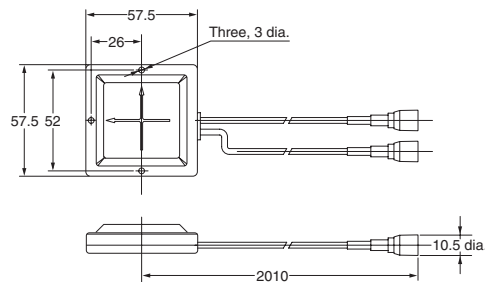

Pencil Antenna

WT30-AT003

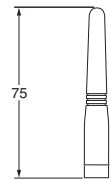

DIN Rail Mounting Bracket

**WT30-FT001
WT30-FT002**



Surface Mounting Bracket

WT30-FT003



Flat Diversity Antenna Mounting Brackets (with magnets)

WT30-FT011



ALL DIMENSIONS SHOWN ARE IN MILLIMETERS.

To convert millimeters into inches, multiply by 0.03937. To convert grams into ounces, multiply by 0.03527.

Cat. No. N139-E1-01 **In the interest of product improvement, specifications are subject to change without notice.**

OMRON Corporation

Industrial Automation Company

Industrial Devices and Components Division H.Q.

Wireless Components Department

Shiokoji Horikawa, Shimogyo-ku,

Kyoto, 600-8530 Japan

Tel: (81)75-344-7116/Fax: (81)75-344-7189

Printed in Japan

0105