

Vision Accessory Catalog



Best Solutions for Quality Inspection and Control

With a complete line-up of Lights and Lenses, advanced Vision Sensors, and 30 years of vision solutions knowhow, OMRON provides solutions to maintain your quality, increase the precision of your machines, and reduce your implementation costs.

LED Lights Constant voltage type FLV Series

Bar Light	FLV-BR	Uniform illumination over wide areas		p4
Direct Ring Light	FLV-DR	Used on non-specular surfaces and area lighting		p7
Low Angle Ring Light	FLV-DL	Perfect for defect and profile detection		p10
Coaxial Light	FLV-CL	Ideal for defect and character inspection on mirror surfaces		p12
Shadowless Ring Light	FLV-FR	Eliminate local reflections on glossy surfaces		p14
Shadowless Low Angle Ring Light	FLV-FP	Suitable for edge detection of glossy objects		p16
Shadowless Dome Ring Light	FLV-FS	Uniform diffused illumination ideal for irregular surfaces		p17
Shadowless Square Light	FLV-FQ	Provides even illumination across squared areas		p18
Spot Light	FLV-EP50	Uniform, parallel light for long-distance part detection		p19
High-power Spot Light	FLV-EP08	Used with coaxial lens to detect alignment mark		p20
Direct Back Light	FLV-DB	High-brightness flat-surface lights for profile measurements		p22
Edge Type Light	FLV-FB	Ultrathin flat-surface light fits into narrow spaces		p24
Edge Type Coaxial Light	FLV-FX	Uniform diffused illumination with many effects such as backlighting and coaxial lighting		p26
Dome Light	FLV-DD	Uniform illumination from all directions for irregular surfaces		p28
Line Light	FLV-LN	High uniformity and brightness ideal for high-speed processing		p30
Camera-mount Lighting Controller for FLV Series	FLV-TCC	Camera-mount controller to save space and simplify wiring		p32
Analog Lighting Controller for FLV Series	FLV-ATC	Stationary type suitable for high power consumption lights		p38
Digital Lighting Controller for FLV Series	3Z4S-LT IDGB	PWM light control power unit for LED lights		p45
FLV Series Options				p48







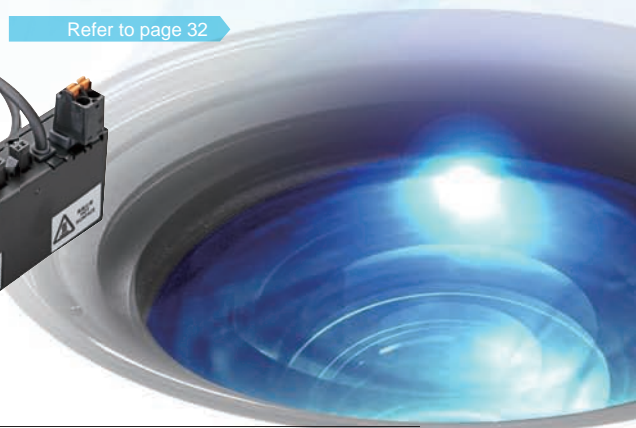



OMRON's unique Camera-mount Lighting Controller helps reduce your implementation costs by reducing wiring work, saving space in the control panel, and easily setting luminance control without programming.

Refer to page 32







LED Lights Constant current type FL Series

MDMC Light	FL-MD	Flexibly changes colors and angles	 p51
Photometric Stereo Light	FL-PS	Shows defects accurately	 p53
High-brightness LED Light 				
• Bar Light	FL-BR	High-brightness bar light suitable for high-speed lines	 p55
• Direct Ring Light	FL-DR	High brightness ring light suitable for high-speed lines	 p58
Camera-mount Lighting Controller for High-brightness LED Lights	FL-TCC	Camera-mount controller to save space and simplify wiring	 p61
Digital Lighting Controller for High-brightness LED Lights	FL-STC	Small body with digital light control to fit in any location	 p63
Lighting Controller for Photometric Stereo Lights	FL-TCC1PS	Camera-mount controller eliminates the need to control light emission timing	 p66
FL Series Option			 p67

Lenses

Lens Selection p70
Standard Lens p71
Telecentric Lens p77
Vibrations and Shocks Resistant Lens p81

Options

• Polarizing Filter	SV-PL	Filters to prevent diffused reflection	 p89
• Protection Cover Filter	SV-GA	Covers to protect lens surfaces from dust	 p89
• Extension Tubes	SV-EXR			
For C-mount Cameras				
For M42-mount Cameras	VS-EXR/M42	Mounted to lenses to change field of view or working distance	 p90
For Small Digital CCD Cameras	FZ-LESR			
• Rear Converter Lens	SV-1.5X/2.0X	Mounted to lenses to change field of view or working distance	 p90
• M42 - F Mount Conversion Adapter	FH-ADF/M42-10	Adapter to connect F mount lenses to M42 cameras	 p90

Optical Chart p91
Safety Precautions p101

Bar Light FLV-BR Series

Many color and size variations are available to uniformly illuminate wide surfaces.

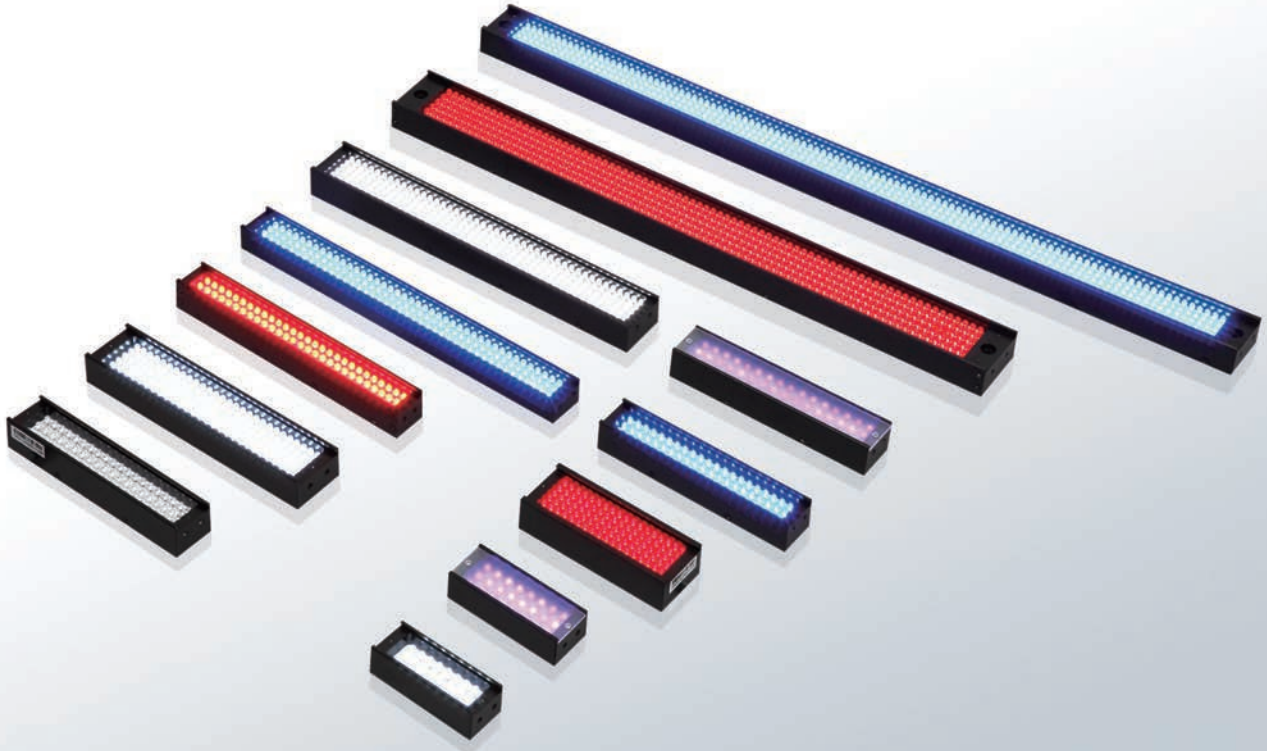

Product Features

- Ideal for illumination of wide, rectangular surfaces.
- Many color and size variations.

Cross-sectional Diagram

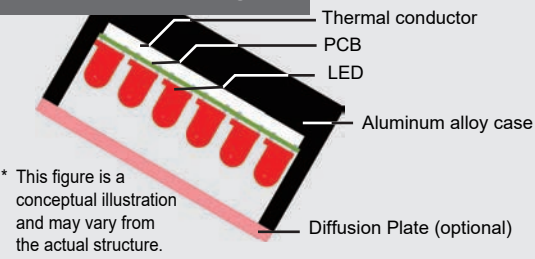
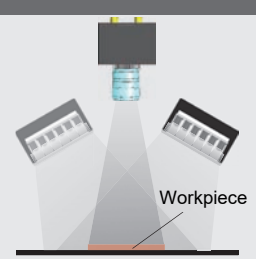

Illustration of Illumination



Applications

Detection of metal surfaces

Detection of cracks on surfaces

Detection of LCD panels

Positioning of LED Packages

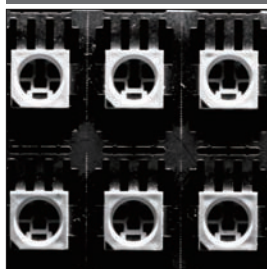

Detection of Faulty LGA Electrodes



Detection of Printed Logo Marks and Characters on Long Workpieces



Ordering Information

Model	Color	Power consumption (W)	Dimensions				Controller *			Weight (g)	Options	
			Lighting Area Dimension (mm)	Outside Dimension (mm)	Height (mm)	Drawing	FLV-TCC□	FLV-ATC□	3Z4S-LT IDGB□		Diffusion Plate	Polarization Plate
FLV-BR6022W	WHITE	1.4	48×18	60×22	17	A	○	○	○	60	○	○
FLV-BR6022R	RED	1.3					○	○	○			
FLV-BR6022B	BLUE	1.4					○	○	○			
FLV-BR6022IR	IR	0.9					○	○	○			
FLV-BR6424UV	UV	1.8	53×20	64×24	17	J	○	○	○	70	○	×
FLV-BR8532W	WHITE	3.5	73×25	85×32	20	B	○	○	○	130	○	○
FLV-BR8532R	RED	3.1					○	○	○			
FLV-BR8532B	BLUE	3.5					○	○	○			
FLV-BR11222W	WHITE	4.2	100×18	112×22	19	C	○	○	○	100	○	○
FLV-BR11222R	RED	2.6					○	○	○			
FLV-BR11222B	BLUE	4.2					○	○	○			
FLV-BR11222IR	IR	1.8					○	○	○			
FLV-BR11624UV	UV	3.6	105×20	116×24	19	K	○	○	○	120	○	---
FLV-BR14030W	WHITE	6.1	126×25	140×30	19	D	○	○	○	140	○	○
FLV-BR14030R	RED	4.8					○	○	○			
FLV-BR14030B	BLUE	6.1					○	○	○			
FLV-BR15020W	WHITE	5.5	138×16	150×20	19	E	○	○	○	120	○	○
FLV-BR15020R	RED	3.1					○	○	○			
FLV-BR15020B	BLUE	5.5					○	○	○			
FLV-BR21222W	WHITE	8.7	199×18	212×22	16	F	○	○	○	140	○	○
FLV-BR21222R	RED	5.0					○	○	○			
FLV-BR21222B	BLUE	8.7					○	○	○			
FLV-BR21230W	WHITE	8.8	200×25	212×30	19	G	○	○	○	220	○	○
FLV-BR21230R	RED	7.0					○	○	○			
FLV-BR21230B	BLUE	8.8					○	○	○			
FLV-BR21230IR	IR	6.1					○	○	○			
FLV-BR21230UV	UV	7.8	200×25	212×30	19	L	○	○	○	230	○	×
FLV-BR38037W	WHITE	15.9	350×33.2	380×37.2	19	H	×	○	○	430	○	○
FLV-BR38037R	RED	11.3					○	○	○			
FLV-BR38037B	BLUE	15.9					×	○	○			
FLV-BR48031W	WHITE	21.9	450×25	480×31	18	I	×	○	○	460	○	○
FLV-BR48031R	RED	18.0					×	○	○			
FLV-BR48031B	BLUE	21.9					×	○	○			

* For the connectable Lighting Controller models and conditions, refer to the Specifications pages of each Lighting Controller.

FLV-TCC□: page 32

FLV-ATC□: page 38

3Z4S-LT IDGB□: page 45

Note: Refer to page 69 for LED Characteristics.

○: Applicable ×: Not applicable

Bar Light FLV-BR Series

Dimensions

(Unit: mm)

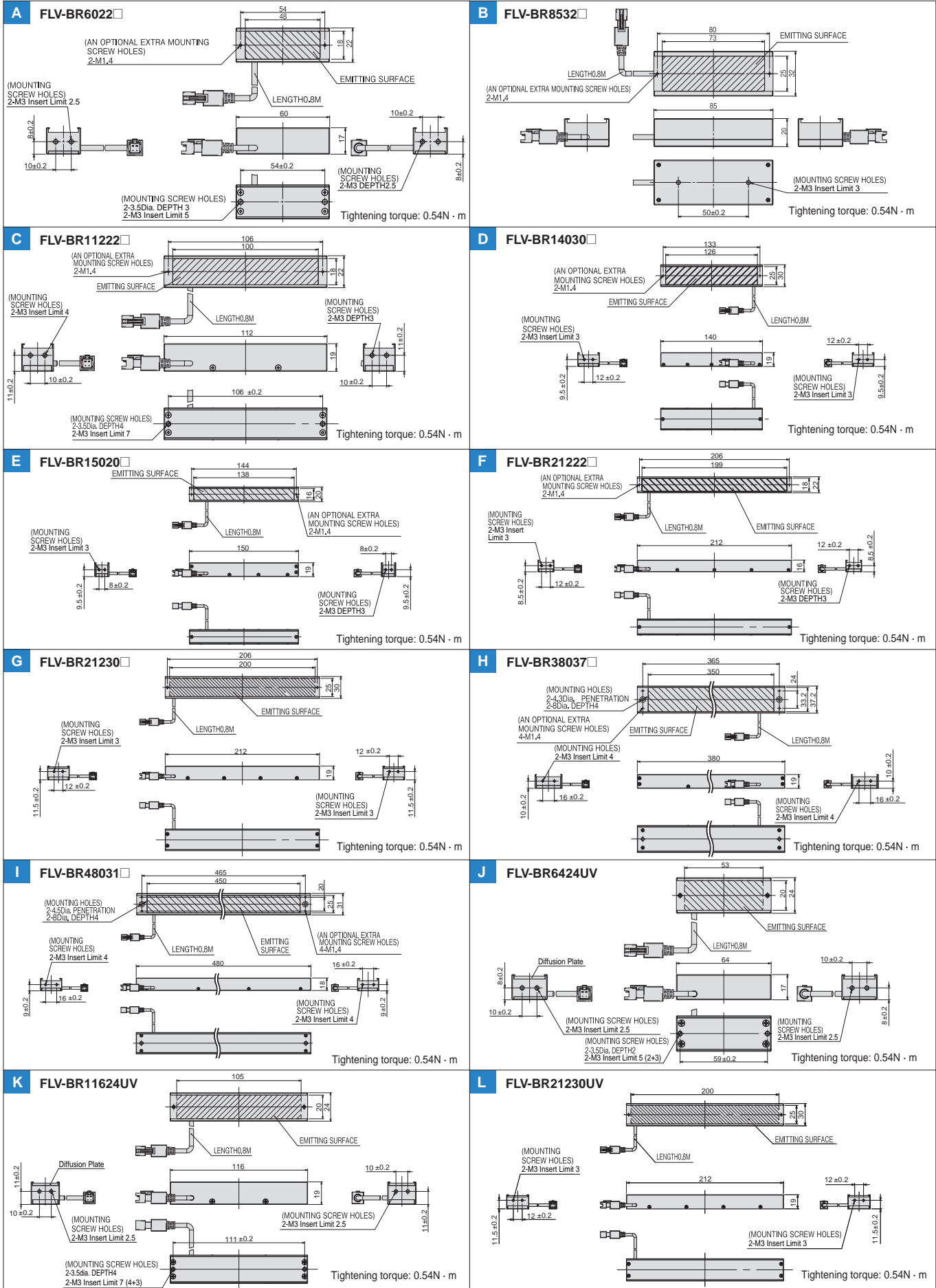

Standard Models
FLV Series

High-brightness Models
FL Series

LED Characteristics

Lenses

Direct Ring Light FLV-DR Series

Standard Models
FLV Series

High-brightness Models
FL Series

LED Characteristics

Lenses

Many shape and size variations are available to detect appearance of various workpieces.



Product Features

- Bright illumination with high-density LED arrays.
- Compact designs that save installation space.
- Optional Diffusion Plates for uniform illumination.

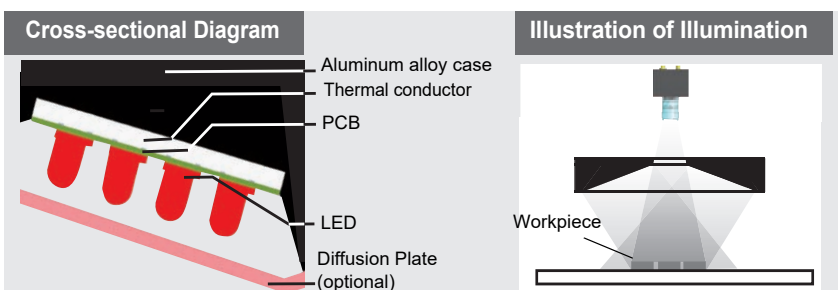

* This figure is a conceptual illustration and may vary from the actual structure.

Applications

Detection of parts on PCBs

Detection of parts and printing on automotive components

Inspection of defects on mouth tops of PET bottles

Standard character recognition and code reading

Detection of parts on PCBs

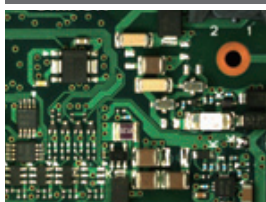

Detection of printing



Direct Ring Light FLV-DR Series

Ordering Information

Model	Color	Power consumption (W)	Dimensions				Controller *			Weight (g)	Options	
			External Ring Diameter (mm)	Internal Ring Diameter (mm)	Lighting Angle (Deg)	Drawing	FLV-TCC□	FLV-ATC□	3Z4S-LT IDGB□		Diffusion Plate	Polarization Plate
FLV-DR3220W	WHITE	1.4	32 dia.	10 dia.	20 deg.	A	○	○	○	60	○	○
FLV-DR3220R	RED	1.3					○	○	○			
FLV-DR3220B	BLUE	1.4					○	○	○			
FLV-DR4415W	WHITE	2.7	44 dia.	17 dia.	15 deg.	B	○	○	○	70	○	○
FLV-DR4415R	RED	1.7					○	○	○			
FLV-DR4415B	BLUE	2.7					○	○	○			
FLV-DR5030W	WHITE	3.1	50 dia.	26.5 dia.	30 deg.	C	○	○	○	60	○	○
FLV-DR5030R	RED	1.8					○	○	○			
FLV-DR5030B	BLUE	3.1					○	○	○			
FLV-DR5030IR	IR	1.3					○	○	○			
FLV-DR6030UV	UV	3.2	64 dia.	26.5 dia.	30 deg.	O	○	○	○	90	○	×
FLV-DR6615W	WHITE	5.0	66 dia.	31 dia.	15 deg.	D	○	○	○	120	○	○
FLV-DR6615R	RED	3.9					○	○	○			
FLV-DR6615B	BLUE	5.0					○	○	○			
FLV-DR7000W	WHITE	5.0	70 dia.	33 dia.	0 deg.	E	○	○	○	110	○	○
FLV-DR7000R	RED	3.7					○	○	○			
FLV-DR7000B	BLUE	5.0					○	○	○			
FLV-DR7030W	WHITE	5.0	70 dia.	30 dia.	30 deg.	F	○	○	○	120	○	○
FLV-DR7030R	RED	3.7					○	○	○			
FLV-DR7030B	BLUE	5.0					○	○	○			
FLV-DR7030IR	IR	2.6					○	○	○			
FLV-DR7530UV	UV	5.4	79 dia.	30 dia.	30 deg.	P	○	○	○	150	○	×
FLV-DR9000W	WHITE	8.8	90 dia.	30 dia.	0 deg.	G	○	○	○	230	○	○
FLV-DR9000R	RED	7.0					○	○	○			
FLV-DR9000B	BLUE	8.8					○	○	○			
FLV-DR9030W	WHITE	8.1	90 dia.	40 dia.	30 deg.	H	○	○	○	200	○	○
FLV-DR9030R	RED	6.6					○	○	○			
FLV-DR9030B	BLUE	8.1					○	○	○			
FLV-DR9030IR	IR	4.3					○	○	○			
FLV-DR9030UV	UV	6.8	94 dia.	40 dia.	30 deg.	Q	○	○	○	220	○	×
FLV-DR9215W	WHITE	7.4	92 dia.	47 dia.	15 deg.	I	○	○	○	200	○	○
FLV-DR9215R	RED	5.4					○	○	○			
FLV-DR9215B	BLUE	7.4					○	○	○			
FLV-DR12030W	WHITE	11.9	120 dia.	60 dia.	30 deg.	J	○	○	○	360	○	○
FLV-DR12030R	RED	9.8					○	○	○			
FLV-DR12030B	BLUE	11.9					○	○	○			

* For the connectable Lighting Controller models and conditions, refer to the Specifications pages of each Lighting Controller.

FLV-TCC□: page 32 FLV-ATC□: page 38 3Z4S-LT IDGB□: page 45

Note: Refer to page 69 for LED Characteristics.

○: Applicable ✕: Not applicable

Dimensions

(Unit: mm)

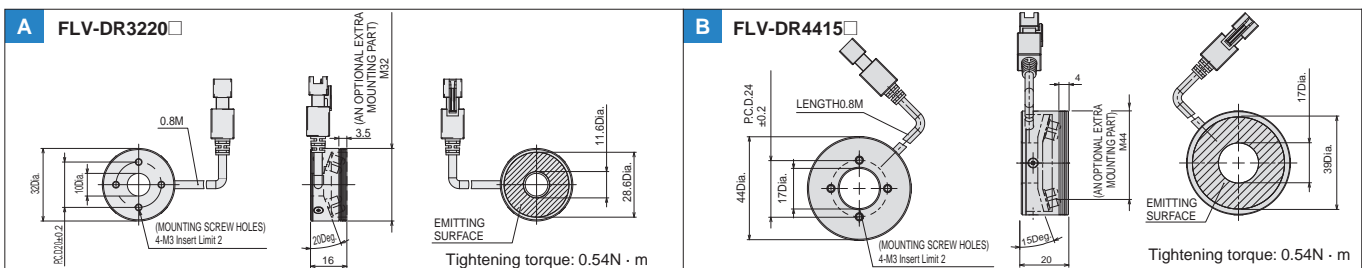

Dimensions

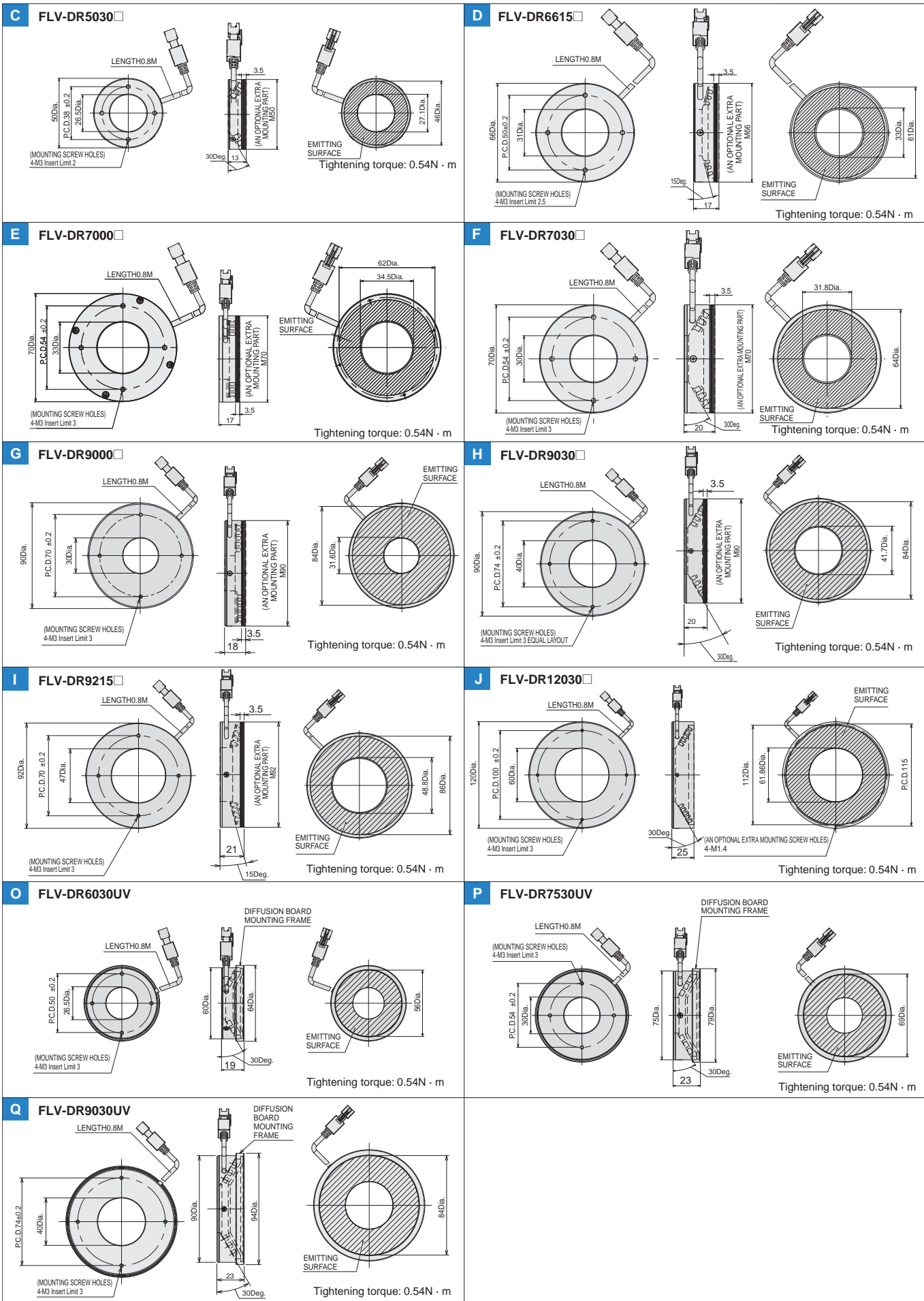

Standard Models
FLV Series

High-brightness Models
FL Series

LED Characteristics

Lenses

Low Angle Ring Light FLV-DL Series

Angled or horizontal illumination emphasizes defects and profiles of workpieces.



Product Features

- Bright illumination with high-density LED arrays.
- Compact designs that save installation space.
- Optional Diffusion Plates for uniform illumination.

Cross-sectional Diagram

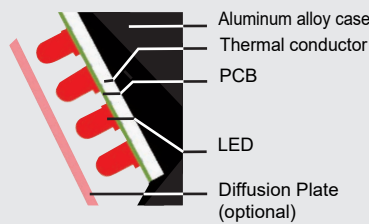
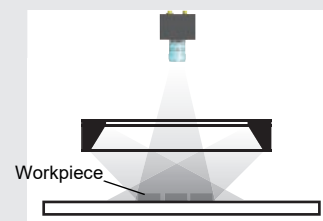

Illustration of Illumination



* This figure is a conceptual illustration and may vary from the actual structure.

Applications

Detection of marking and defects on surfaces of metal workpieces

Detection of foreign matter in medicines

Detection of chips on circumference of O rings

Surface and profile inspection of metal workpieces



Ring Light



Low Angle Ring Light

Ordering Information

Model	Color	Power consumption (W)	Dimensions				Controller *			Weight (g)	Options	
			External Ring Diameter (mm)	Internal Ring Diameter (mm)	Lighting Angle (Deg)	Drawing	FLV-TCC□	FLV-ATC□	3Z4S-LT IDGB□		Diffusion Plate	Polarization Plate
FLV-DL5890W	WHITE	1.9	58 dia.	27 dia.	90 deg.	J	○	○	○	90	○	×
FLV-DL5890R	RED	1.3					○	○	○			
FLV-DL5890B	BLUE	1.9					○	○	○			
FLV-DL7260W	WHITE	5.7	72 dia.	44 dia.	60 deg.	K	○	○	○	120	○	○
FLV-DL7260R	RED	3.9					○	○	○			
FLV-DL7260B	BLUE	5.7					○	○	○			
FLV-DL9090W	WHITE	2.8	90 dia.	50 dia.	90 deg.	L	○	○	○	100	×	×
FLV-DL9090R	RED	1.8					○	○	○			
FLV-DL9090B	BLUE	2.8					○	○	○			
FLV-DL12060W	WHITE	12.7	120 dia.	67 dia.	60 deg.	M	○	○	○	310	○	○
FLV-DL12060R	RED	10.5					○	○	○			
FLV-DL12060B	BLUE	12.7					○	○	○			
FLV-DL15060W	WHITE	13.6	150 dia.	108 dia.	60 deg.	N	○	○	○	260	○	○
FLV-DL15060R	RED	11.2					○	○	○			
FLV-DL15060B	BLUE	13.6					○	○	○			

* For the connectable Lighting Controller models and conditions, refer to the Specifications pages of each Lighting Controller.

FLV-TCC□: page 32 FLV-ATC□: page 38 3Z4S-LT IDGB□: page 45

Note: Refer to page 69 for LED Characteristics.

○: Applicable ×: Not applicable

Dimensions

(Unit: mm)

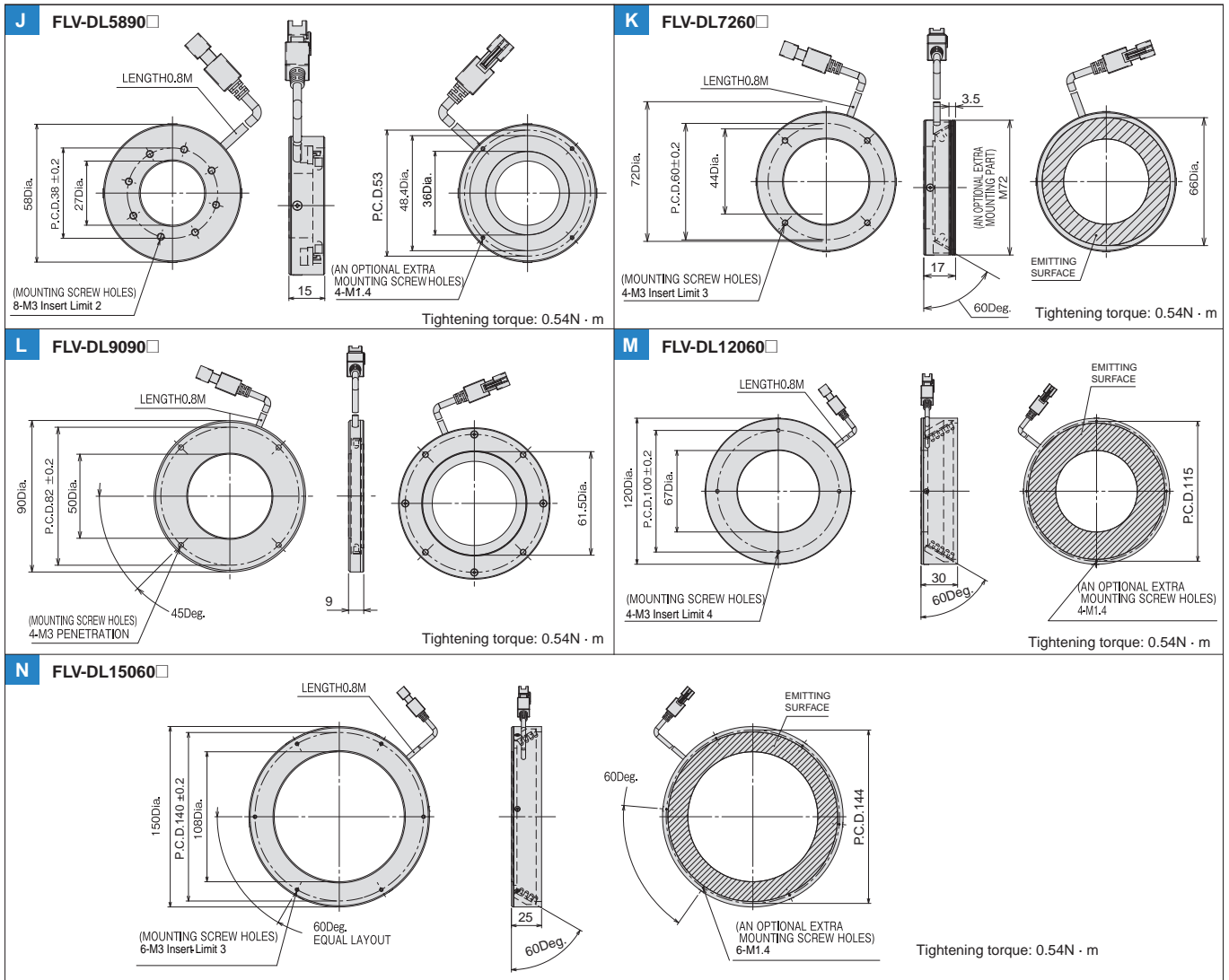

Coaxial Light FLV-CL Series

Standard Models
FLV Series

High-brightness Models
FL Series

LED Characteristics

Lenses

Coaxial illumination with the Lens helps prevent interference from reflected light. This series is ideal for surface damage and character inspections on highly reflective workpieces with mirror-like surfaces.

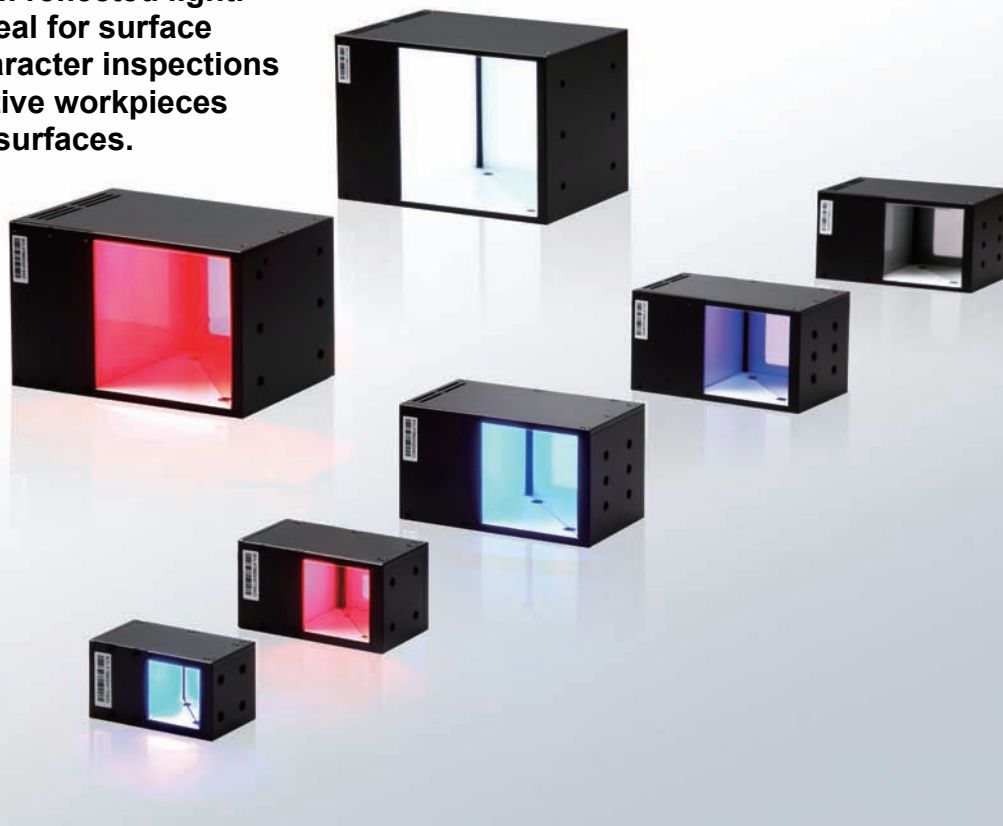

Product Features

- Long life and stability result from a structure with optimum heat dissipation.
- Uniform illumination for clear images.

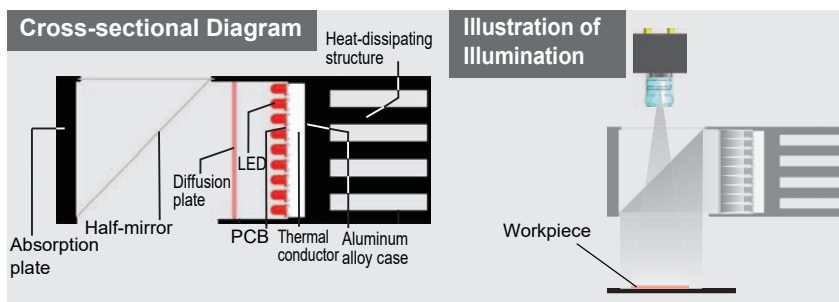

* This figure is a conceptual illustration and may vary from the actual structure.

Applications

Inspection for scratches on highly reflective surfaces

Inspection for damages on chips and silicon wafers

Detection of positioning marks

Recognition of bar codes on packages

Recognition of laser-marked characters and 2D DMP codes

General exterior detection

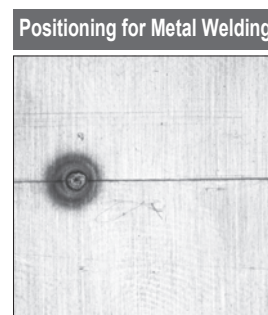
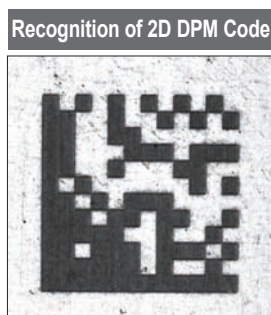
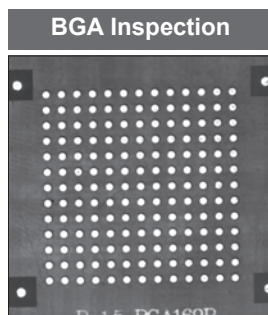

Ordering Information

Model	Color	Power consumption (W)	Dimension				Controller *			Weight (g)
			Lighting Area Dimension (mm)	Outside Dimension (mm)	Height (mm)	Drawing	FLV-TCC□	FLV-ATC□	3Z4S-LT IDGB□	
FLV-CL30W	WHITE	2.4	24×25	32×59.5	31	A	○	○	○	110
FLV-CL30R	RED	1.4					○	○	○	
FLV-CL30B	BLUE	2.4					○	○	○	
FLV-CL40W	WHITE	3.9	34×34	40×74	40	B	○	○	○	170
FLV-CL40R	RED	2.3					○	○	○	
FLV-CL40B	BLUE	3.9					○	○	○	
FLV-CL60W	WHITE	10.4	51×52	58×104	60.5	C	○	○	○	380
FLV-CL60R	RED	5.7					○	○	○	
FLV-CL60B	BLUE	10.4					○	○	○	
FLV-CL60IR	IR	3.9					○	○	○	
FLV-CL60UV	UV	3.0					○	○	○	
FLV-CL80W	WHITE	10.8	72×72	78×124	77.5	D	○	○	○	580
FLV-CL80R	RED	7.2					○	○	○	
FLV-CL80B	BLUE	10.8					○	○	○	
FLV-CL100W	WHITE	22.7	92×92	98×141	99.5	E	×	○	○	820
FLV-CL100R	RED	15.2					×	○	○	
FLV-CL100B	BLUE	22.7					×	○	○	

* For the connectable Lighting Controller models and conditions, refer to the Specifications pages of each Lighting Controller.

FLV-TCC□: page 32 FLV-ATC□: page 38 3Z4S-LT IDGB□: page 45

Note: Refer to page 69 for LED Characteristics.

○: Connectable ×: Not connectable

Dimensions

(Unit: mm)

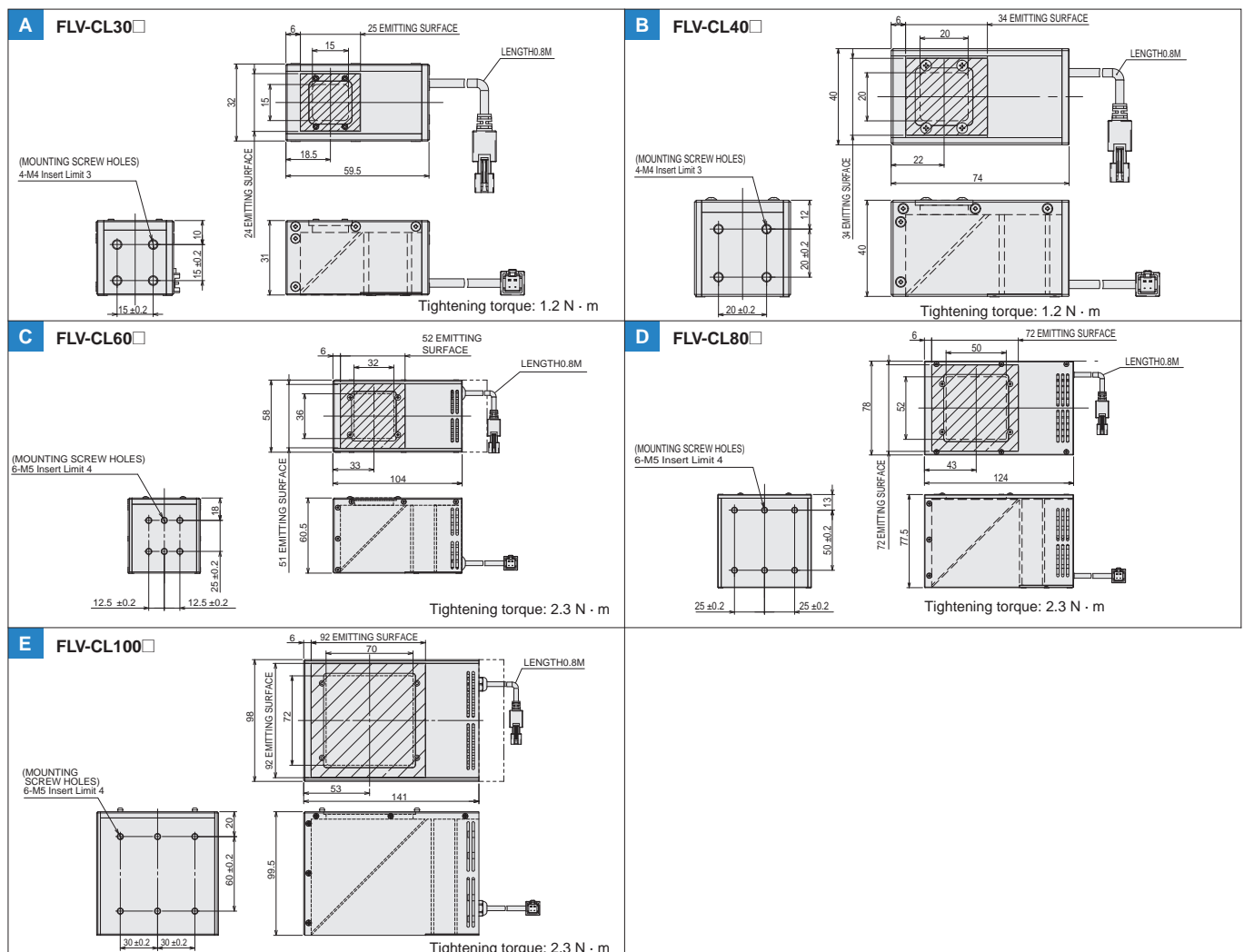

Shadowless Ring Light FLV-FR Series

This series effectively eliminates the influences of localized reflections for the surfaces of small workpieces.



Product Features

- Special diffusion plates create greater uniformity in lighting than normal ring lighting.

Cross-sectional Diagram

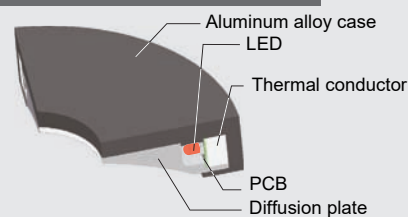
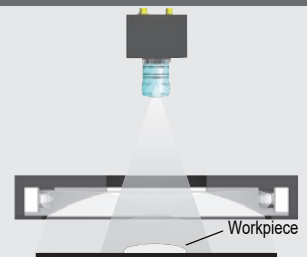

Illustration of Illumination



* This figure is a conceptual illustration and may vary from the actual structure.

Applications

Character inspections on electronic components or formed plastic parts

Character Detection on Capacitor Surface



Image with Normal Ring Lighting



Image with the FLV-FR114R

Standard Models
FLV Series

High-brightness Models
FL Series

LED Characteristics

Lenses

Ordering Information

Model	Color	Power consumption (W)	Dimensions				Controller *			Weight (g)
			External Ring Diameter (mm)	Internal Ring Diameter (mm)	Lighting Area Diameter (mm)	Drawing	FLV-TCC□	FLV-ATC□	3Z4S-LT IDGB□	
FLV-FR114W	WHITE	3.9	114 dia.	40 dia.	92 dia.	A	○	○	○	270
FLV-FR114R	RED	3.1					○	○	○	
FLV-FR114B	BLUE	3.9					○	○	○	
FLV-FR150W	WHITE	6.1	150 dia.	40 dia.	123 dia.	B	○	○	○	500
FLV-FR150R	RED	3.5					○	○	○	
FLV-FR150B	BLUE	6.1					○	○	○	

* For the connectable Lighting Controller models and conditions, refer to the Specifications pages of each Lighting Controller.

FLV-TCC□: page 32

FLV-ATC□: page 38

3Z4S-LT IDGB□: page 45

Note: Refer to page 69 for LED Characteristics.

○: Connectable

Dimensions

(Unit: mm)

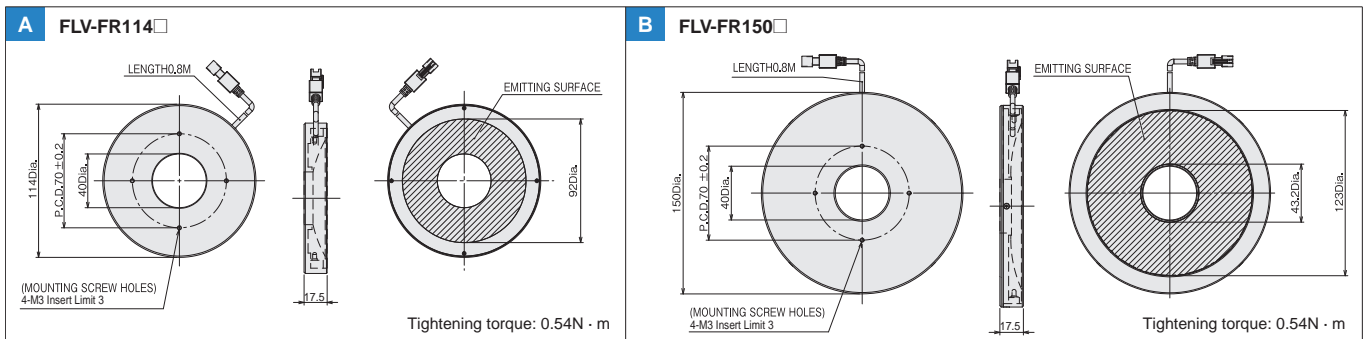

Shadowless Low Angle Ring Light FLV-FP Series

This series achieves highly uniform illumination across a wide field of view.
Excellent symmetry eliminates diagonal shadows.



Product Features

- Shadowless Ring Lighting
- Achieve highly uniform illumination and obtain different images at different installation distances for a much wider range of application compared to normal ring lighting.

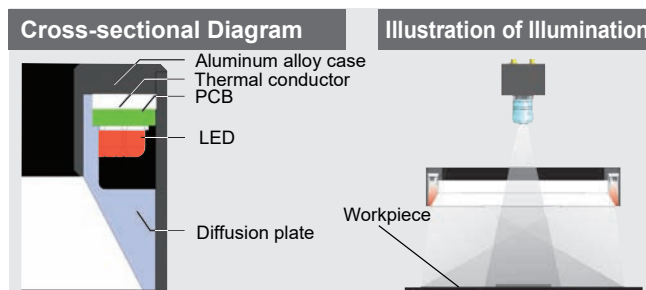

* This figure is a conceptual illustration and may vary from the actual structure.

Ordering Information

Model	Light Color	Power consumption (W)	Dimensions			Drawing	Controller *			Weight (g)
			External Ring Diameter (mm)	Internal Ring Diameter (mm)	Lighting Area Diameter (mm)		FLV-TCC□	FLV-ATC□	3Z4S-LT IDGB□	
FLV-FP130W	WHITE	8.1	130 dia.	100 dia.	120 dia.	A	○	○	○	320
FLV-FP130R	RED	5.8					○	○	○	
FLV-FP130B	BLUE	8.1					○	○	○	

* For the connectable Lighting Controller models and conditions, refer to the Specifications pages of each Lighting Controller.

FLV-TCC□: page 32 FLV-ATC□: page 38 3Z4S-LT IDGB□: page 45

Note: Refer to page 69 for LED Characteristics.

○: Connectable

Applications

Detection of bumps, scratches, and other defects on surfaces

Recognition of marks

Recognition of printed characters

Recognition of barcodes

Recognition of Marked Characters



Dimensions

(Unit: mm)

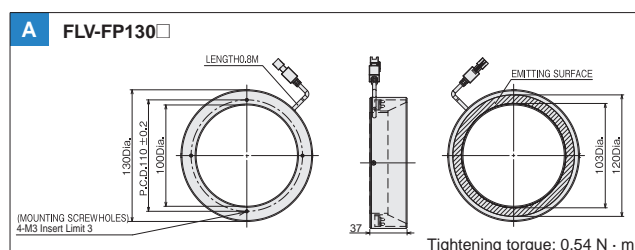

Shadowless Dome Ring Light FLV-FS Series

Highly uniform illumination eliminates the influences of small surface irregularities to highlight features through changes in inclination.



Product Features

- Uniquely designed diffusion plate achieve highly uniform illumination through reflection and diffusion.
- Eliminates the influences of small surface irregularities to highlight features through large differences in inclination.
- Saves space for small workpieces while achieving the benefits of dome lighting.

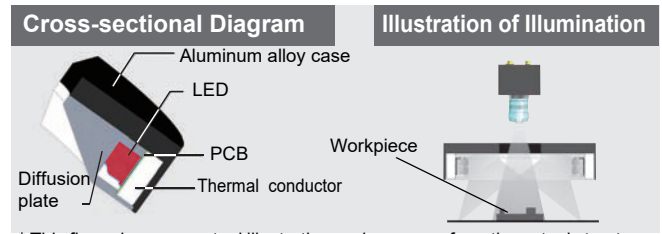

* This figure is a conceptual illustration and may vary from the actual structure.

Ordering Information

Model	Color	Power consumption (W)	Dimensions				Controller *			Weight (g)
			External Ring Diameter (mm)	Internal Ring Diameter (mm)	Lighting Area Diameter (mm)	Drawing	FLV-TCC□	FLV-ATC□	3Z4S-LT IDGB□	
FLV-FS74W	WHITE	5.2	74 dia.	20 dia.	64 dia.	A	<input type="radio"/>	<input type="radio"/>	<input type="radio"/>	140
FLV-FS74R	RED	3.5					<input type="radio"/>	<input type="radio"/>	<input type="radio"/>	
FLV-FS74B	BLUE	5.2					<input type="radio"/>	<input type="radio"/>	<input type="radio"/>	

* For the connectable Lighting Controller models and conditions, refer to the Specifications pages of each Lighting Controller.

FLV-TCC□: page 32 FLV-ATC□: page 38 3Z4S-LT IDGB□: page 45

Note: Refer to page 69 for LED Characteristics.

: Connectable

Applications

Edge positioning and size measurement for metal parts

Gap Position Detection on Multilayered Shafts

Detection of bumps in metal parts



Dimensions

(Unit: mm)

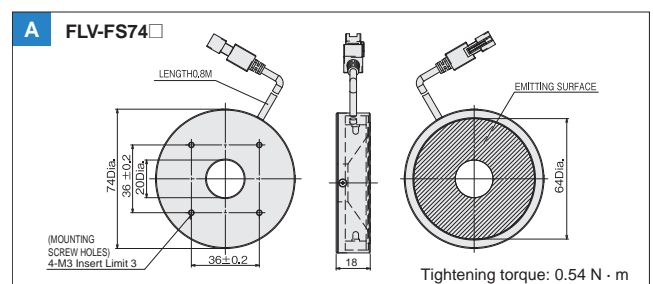

Shadowless Square Light FLV-FQ Series

This series achieves wide highly uniform illumination across a square field of view.



Product Features

- Shadowless Square Lighting
- Achieves highly uniform illumination and obtains different images at different installation distances for a much wider range of applications compared to normal ring lighting.

Cross-sectional Diagram

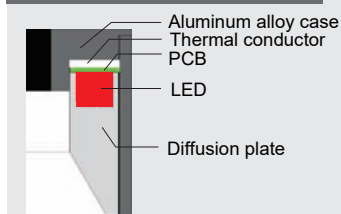
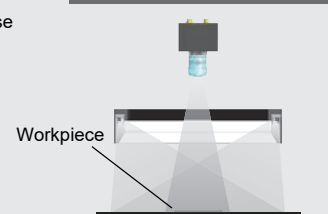

Illustration of Illumination



* This figure is a conceptual illustration and may vary from the actual structure.

Ordering Information

Model	Color	Power consumption (W)	Dimensions				Controller *			Weight (g)
			Lighting Area Dimension (mm)	Outside Dimension (mm)	Height (mm)	Drawing	FLV-TCC□	FLV-ATC□	3Z4S-LT IDGB□	
FLV-FQ48W	WHITE	2.0	41×41	48 × 48	30	A	○	○	○	100
FLV-FQ48R	RED	1.2					○	○	○	
FLV-FQ48B	BLUE	2.0					○	○	○	

* For the connectable Lighting Controller models and conditions, refer to the Specifications pages of each Lighting Controller.

FLV-TCC□: page 32 FLV-ATC□: page 38 3Z4S-LT IDGB□: page 45

Note: Refer to page 69 for LED Characteristics.

○: Connectable

Applications

Detection of defects on workpiece surfaces

Recognition of printed characters and bar codes

Appearance Inspections of Chip Components



Dimensions

(Unit: mm)

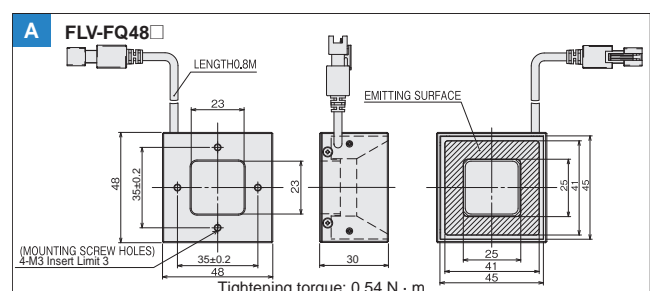

Spot Light FLV-EP50 Series

Standard Models
FLV Series

High-brightness Models
FL Series

LED Characteristics

Lenses

Long-distance Spot Lighting
This series achieves uniform, parallel light.



Product Features

- Superior directional characteristic, essentially parallel light, and long-distance illumination.

Cross-sectional Diagram

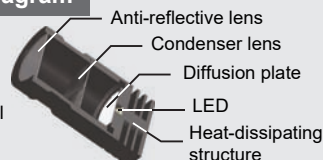

*This figure is a conceptual illustration and may vary from the actual structure.

Illustration of Illumination

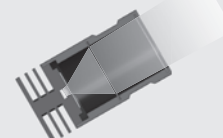

Ordering Information

Model	Color	Power consumption (W)	Dimensions				Controller *			Weight (g)
			Lighting Area Dimension (mm)	Outside Dimension (mm)	Height (mm)	Drawing	FLV-TCC□	FLV-ATC□	3Z4S-LT IDGB□	
FLV-EP50W	WHITE	1.6	40 dia.	50 dia.	94.5	A	○	○	×	200
FLV-EP50R	RED	1.1					○	○	×	

* For the connectable Lighting Controller models and conditions, refer to the Specifications pages of each Lighting Controller.

FLV-TCC□: page 32 FLV-ATC□: page 38 3Z4S-LT IDGB□: page 45

Note: Refer to page 69 for LED Characteristics.

○: Connectable

Applications

Size measurements of small workpieces

Detection of defects on surfaces

Detection of Gaps in Small Parts



Detection of Scratches on Card Surfaces



Dimensions

(Unit: mm)

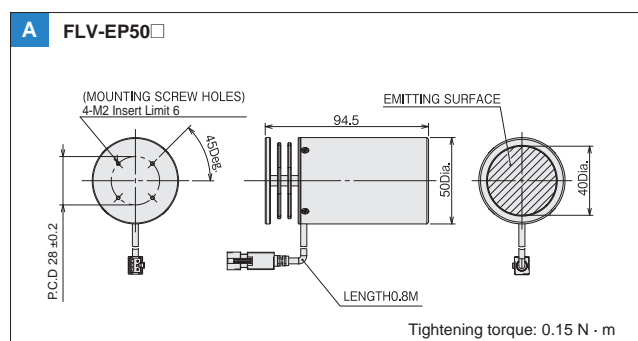

High-power Spot Light FLV-EP08 Series

High-power, Compact Spot Light Sources.



Product Features

- High-power LEDs generate strong light with a compact design.
- Ideal for applications in combination with a Coaxial Lens.
- Highly efficient heat-dissipating structure ensures a long life.

Cross-sectional Diagram

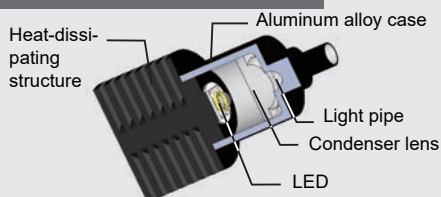
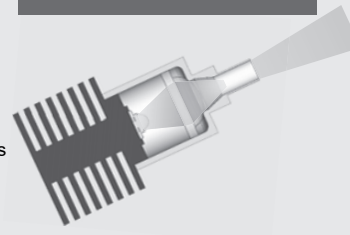

Illustration of Illumination



* This figure is a conceptual illustration and may vary from the actual structure.

Applications

Detection of alignment marks

Detection of chips

Detection of defects on workpiece surfaces

Illustration of Illumination in Combination with a Coaxial Lens

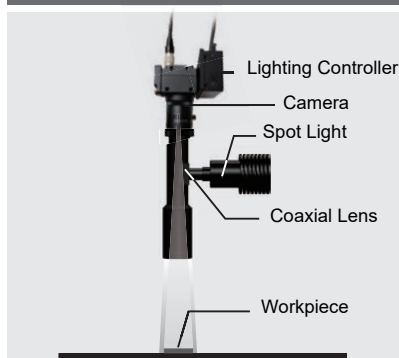

Simplified Illustration of Detection of Bubbles in Transparent Material

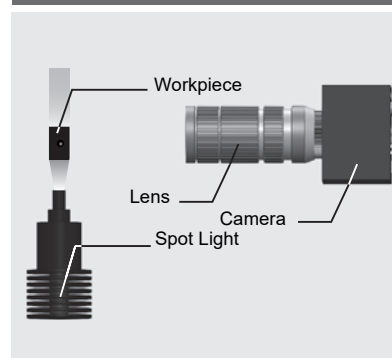

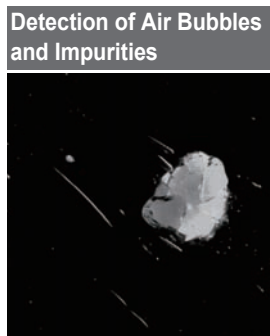
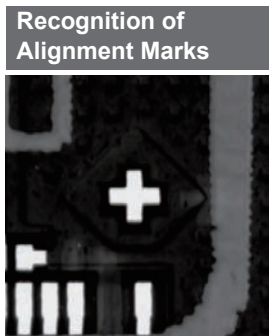

Ordering Information

Model	Color	Power consumption (W)	Dimensions				Controller *			Weight (g)
			Lighting Area Dimension (mm)	Outside Dimension (mm)	Height (mm)	Drawing	FLV-TCC□	FLV-ATC□	3Z4S-LT IDGB□	
FLV-EP0803W	WHITE	1.6	6.8 dia.	28 dia.	60	A	○	○	×	80
FLV-EP0803R	RED	1.1					○	○	×	
FLV-EP0803B	BLUE	1.6					○	○	×	

* For the connectable Lighting Controller models and conditions, refer to the Specifications pages of each Lighting Controller.

FLV-TCC□: page 32

FLV-ATC□: page 38

3Z4S-LT IDGB□: page 45

Note: Refer to page 69 for LED Characteristics.

○: Connectable

Dimensions

(Unit: mm)

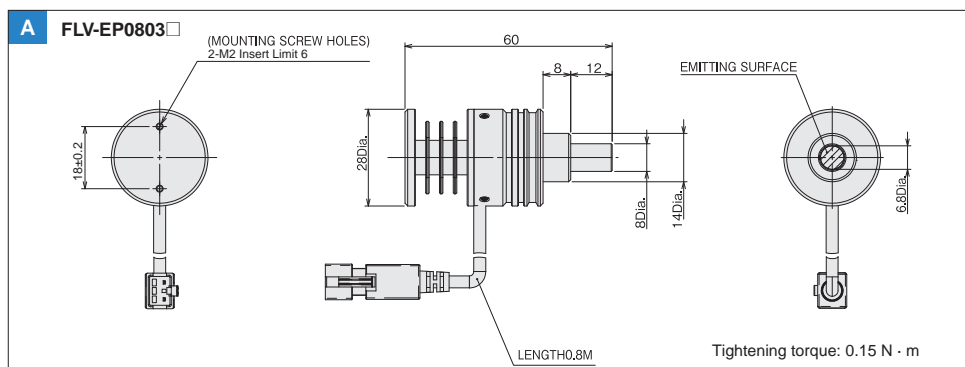

Direct Back Light FLV-DB Series

Uniform Illumination from a Flat Emitting Surface
Illumination from the back of the workpiece produces a high-contrast silhouette.

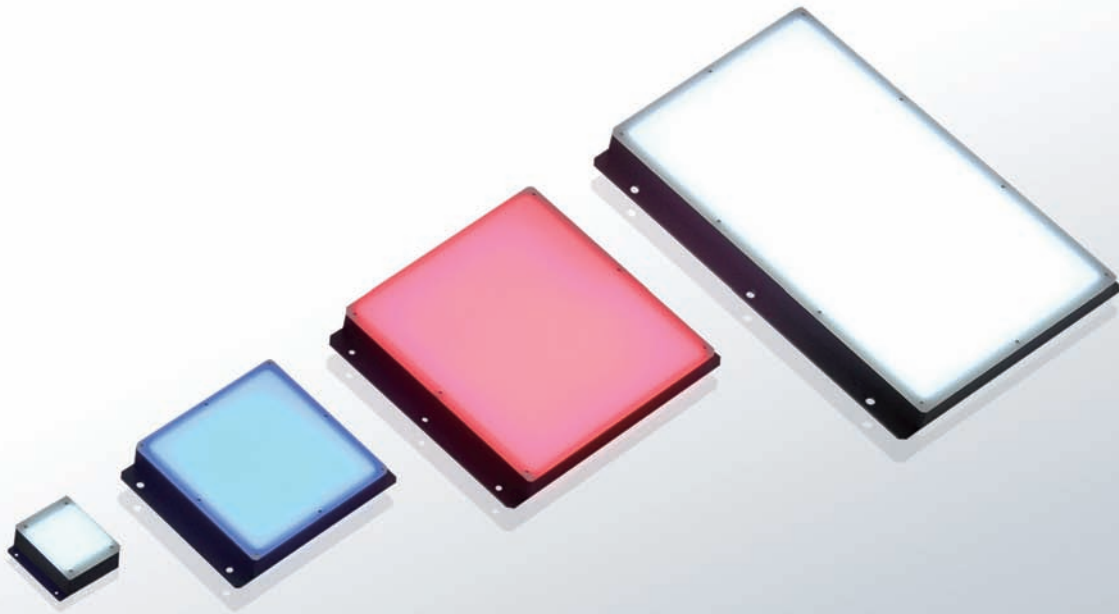

Product Features

- Highly uniform backlighting with high-density LED arrays. Emphasizes the outline features of workpieces.

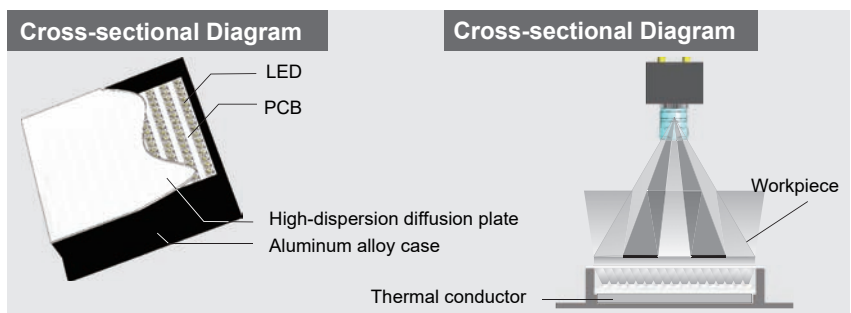

* This figure is a conceptual illustration and may vary from the actual structure.

Applications

- Size measurements of machine parts
- Shape detections for electronic components and ICs
- Dirt detection on films

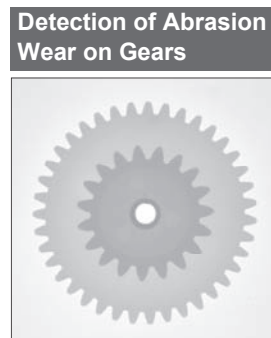
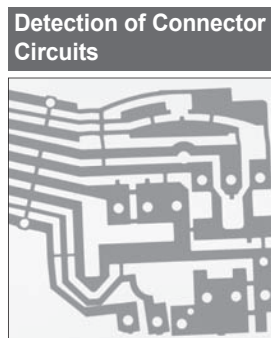

Standard Models
FLV Series

High-brightness Models
FL Series

LED Characteristics

Lenses

Ordering Information

Model	Color	Power consumption (W)	Dimensions				Controller *			Weight (g)
			Lighting Area Dimension (mm)	Outside Dimension (mm)	Height (mm)	Drawing	FLV-TCC□	FLV-ATC□	3Z4S-LT IDGB□	
FLV-DB3729W	WHITE	0.9	27×27	37×37	15	A	○	○	○	50
FLV-DB3729R	RED	0.9					○	○	○	
FLV-DB3729B	BLUE	0.9					○	○	○	
FLV-DB10181W	WHITE	8.1	73×73	101×81	17	B	○	○	○	160
FLV-DB10181R	RED	4.7					○	○	○	
FLV-DB10181B	BLUE	8.1					○	○	○	
FLV-DB130130W	WHITE	13.0	114×120	144×126	17	C	○	○	○	270
FLV-DB130130R	RED	11.5					○	○	○	
FLV-DB130130B	BLUE	13.0					○	○	○	
FLV-DB212152W	WHITE	29.4	200×120	212×152	17	D	×	○	○	510
FLV-DB212152R	RED	20.2					×	○	○	
FLV-DB212152B	BLUE	29.4					×	○	○	

* For the connectable Lighting Controller models and conditions, refer to the Specifications pages of each Lighting Controller

FLV-TCC□: page 32

FLV-ATC□: page 38

3Z4S-LT IDGB□: page 45

Note: Refer to page 69 for LED Characteristics.

○: Connectable ×: Not connectable

Dimensions

(Unit: mm)

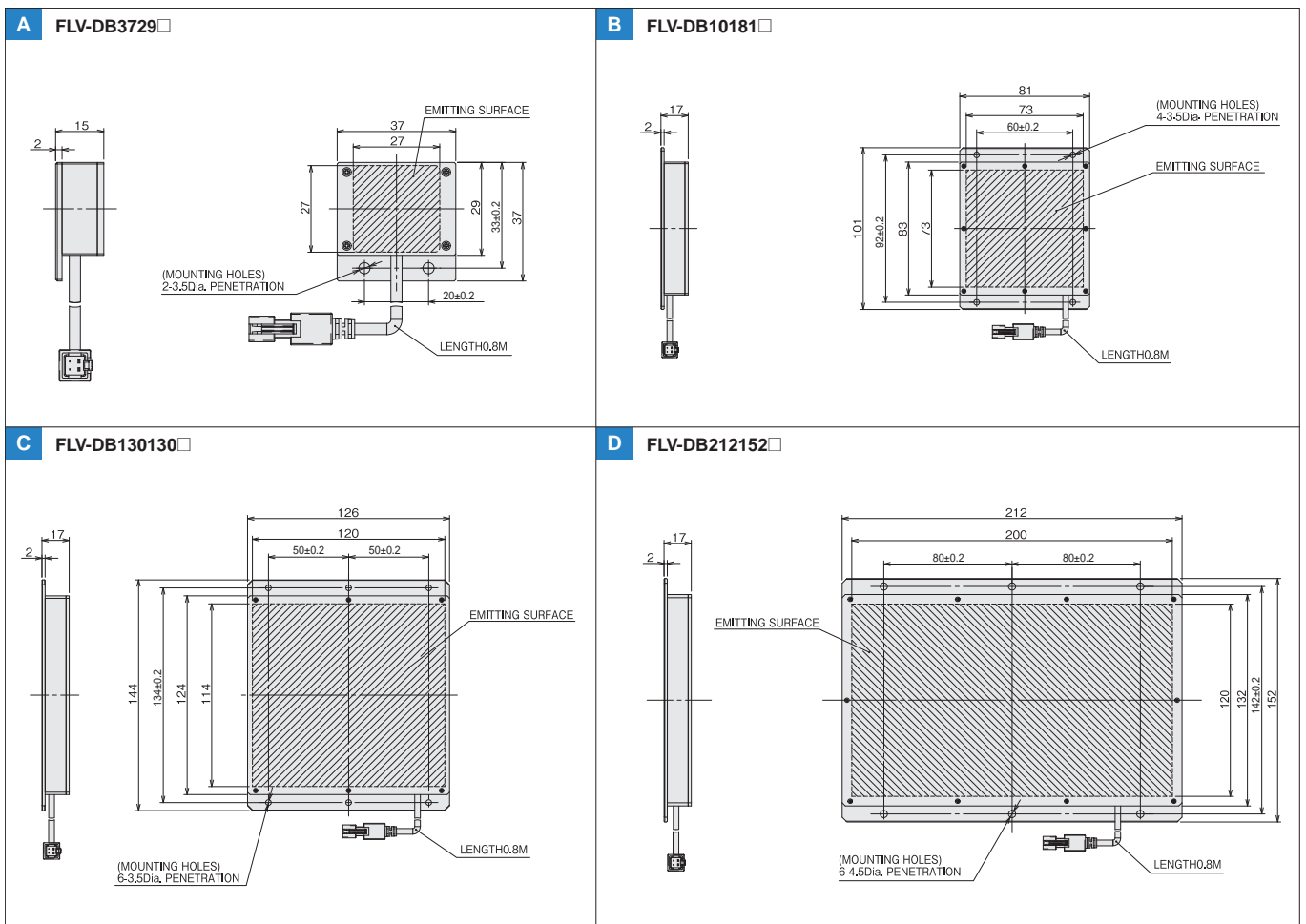

Edge Type Light FLV-FB Series

Ultrathin, Highly Uniform Backlights
Thin enough to conveniently fit into narrow spaces.

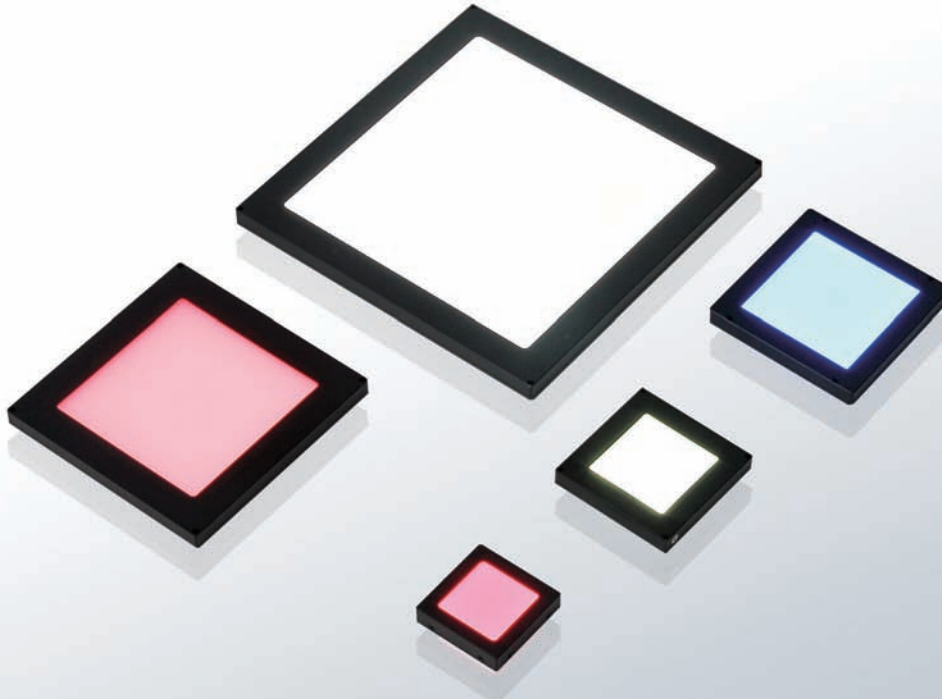

Product Features

- Five size variations with emitting surfaces from 35 mm square to 164 mm square.
- As thin as 8 mm (FLV-FB7070).

Cross-sectional Diagram

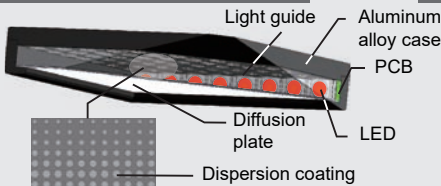
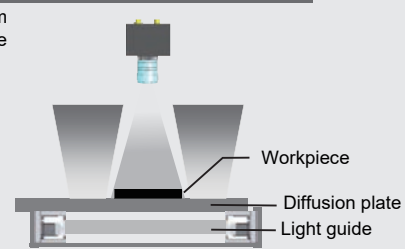

Illustration of Illumination



* This figure is a conceptual illustration and may vary from the actual structure.

Applications

Detection and size measurements of electronic devices

Detection of LCD dead pixels

Detection of Silkscreen Patterns on Cell Phone PCBs

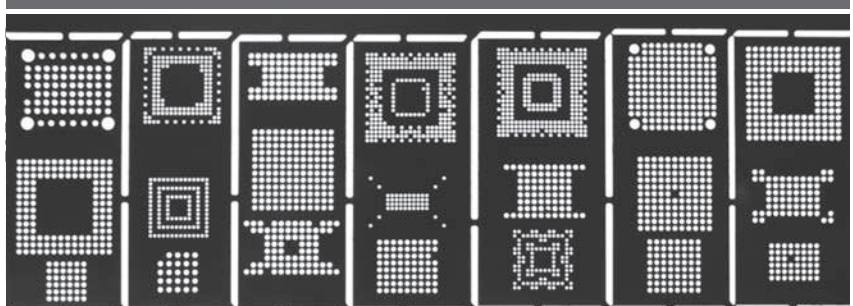

Ordering Information

Model	Color	Power consumption (W)	Dimensions				Controller *			Weight (g)
			Lighting Area Dimension (mm)	Outside Dimension (mm)	Height (mm)	Drawing	FLV-TCC□	FLV-ATC□	3Z4S-LT IDGB□	
FLV-FB5050W	WHITE	1.9	35×35	50×50	11	A	○	○	○	75
FLV-FB5050R	RED	0.9					○	○	○	
FLV-FB5050B	BLUE	1.9					○	○	○	
FLV-FB7070W	WHITE	1.9	46×46	70×70	8	B	○	○	○	85
FLV-FB7070R	RED	1.4					○	○	○	
FLV-FB7070B	BLUE	1.9					○	○	○	
FLV-FB9090W	WHITE	3.7	66×66	90×90	10	C	○	○	○	155
FLV-FB9090R	RED	1.9					○	○	○	
FLV-FB9090B	BLUE	3.7					○	○	○	
FLV-FB130130W	WHITE	5.5	94×94	130×130	10	D	○	○	○	230
FLV-FB130130R	RED	3.7					○	○	○	
FLV-FB130130B	BLUE	5.5					○	○	○	
FLV-FB200200W	WHITE	7.3	164×164	200×200	11	E	○	○	○	710
FLV-FB200200R	RED	5.5					○	○	○	
FLV-FB200200B	BLUE	7.3					○	○	○	

* For the connectable Lighting Controller models and conditions, refer to the Specifications pages of each Lighting Controller.

FLV-TCC□: page 32 FLV-ATC□: page 38 3Z4S-LT IDGB□: page 45

Note: Refer to page 69 for LED Characteristics.

○: Connectable

Dimensions

(Unit: mm)

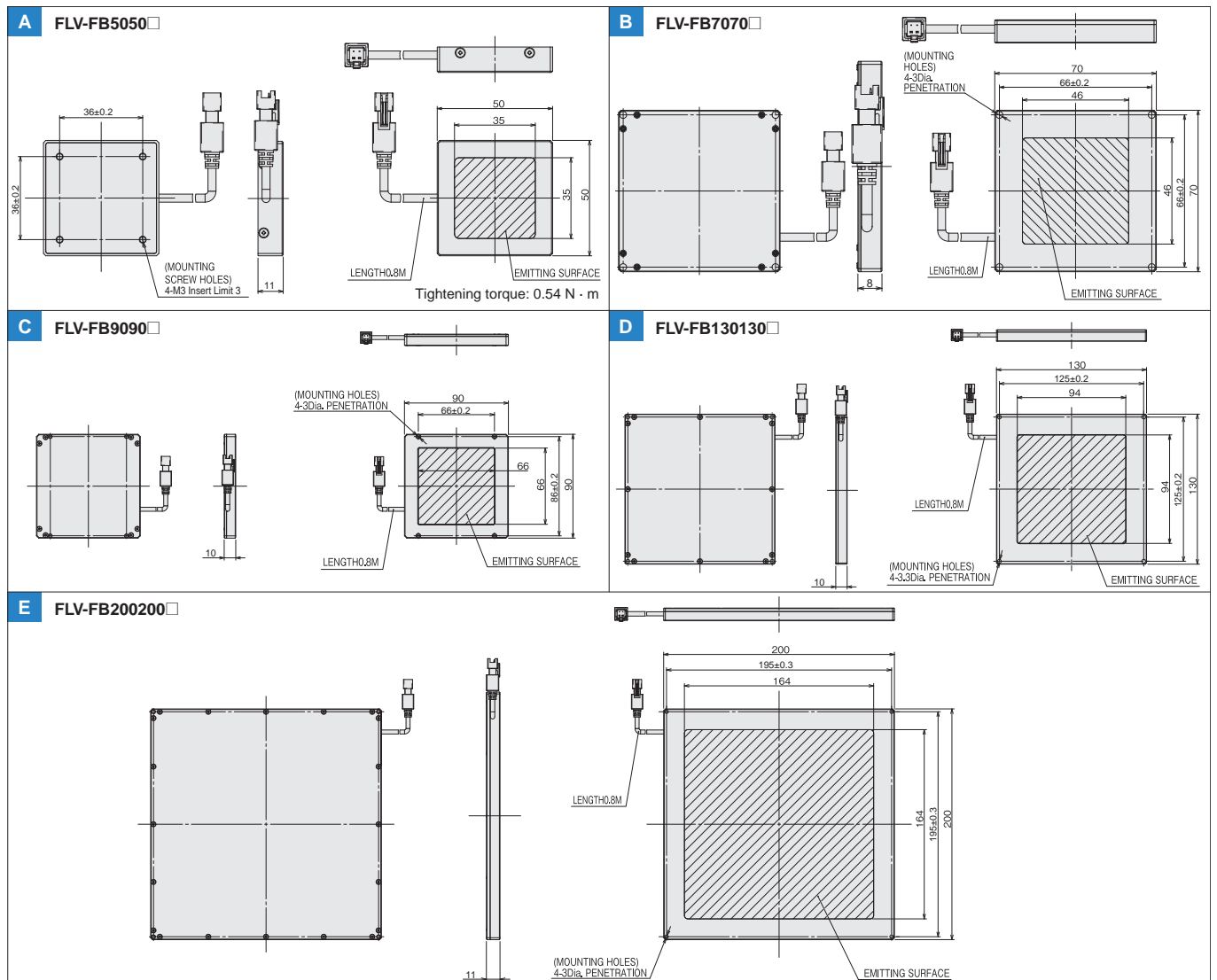

Edge Type Coaxial Light FLV-FX Series

This series features a wide range of applications with many effects, such as backlighting and coaxial lighting.



Product Features

- High uniformity with diffused illumination.
- Achieves both shadowless and coaxial illumination.
- Lightweight and compact to conveniently fit into narrow spaces

Cross-sectional Diagram

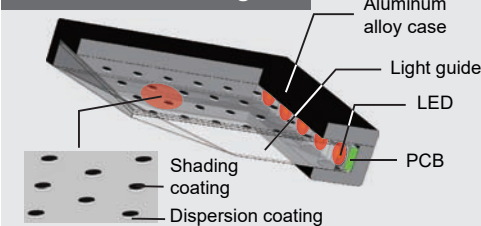
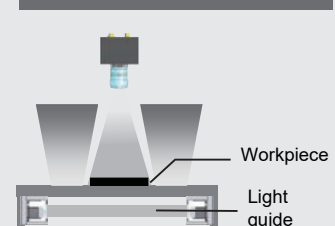

Illustration of Illumination



* This figure is a conceptual illustration and may vary from the actual structure.

Applications

Package inspections for foodstuffs, cigarettes, and household chemicals

Appearance inspections of home appliance cases and components

Detection, measurement, and recognition of characters and figures on highly reflective, uneven surfaces

Detection of Mounting Hole Positions



Inspections for Defects on Metal Parts



Inspections for Defects on Plated Parts

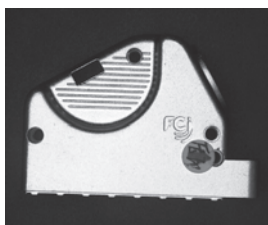

Recognition of Metal Characters and Patterns on Plastic Surfaces



Ordering Information

Model	Color	Power consumption (W)	Dimensions				Controller *			Weight (g)
			Lighting Area Dimension (mm)	Outside Dimension (mm)	Height (mm)	Drawing	FLV-TCC□	FLV-ATC□	3Z4S-LT IDGB□	
FLV-FX100W	WHITE	3.7	60×60	100×100	11	A	○	○	○	180
FLV-FX100R	RED	1.9					○	○	○	
FLV-FX100B	BLUE	3.7					○	○	○	
FLV-FX143W	WHITE	5.5	100×100	143×143	11	B	○	○	○	240
FLV-FX143R	RED	3.7					○	○	○	
FLV-FX143B	BLUE	5.5					○	○	○	

* For the connectable Lighting Controller models and conditions, refer to the Specifications pages of each Lighting Controller.

FLV-TCC□: page 32

FLV-ATC□: page 38

3Z4S-LT IDGB□: page 45

Note: Refer to page 69 for LED Characteristics.

○: Connectable

Dimensions

(Unit: mm)

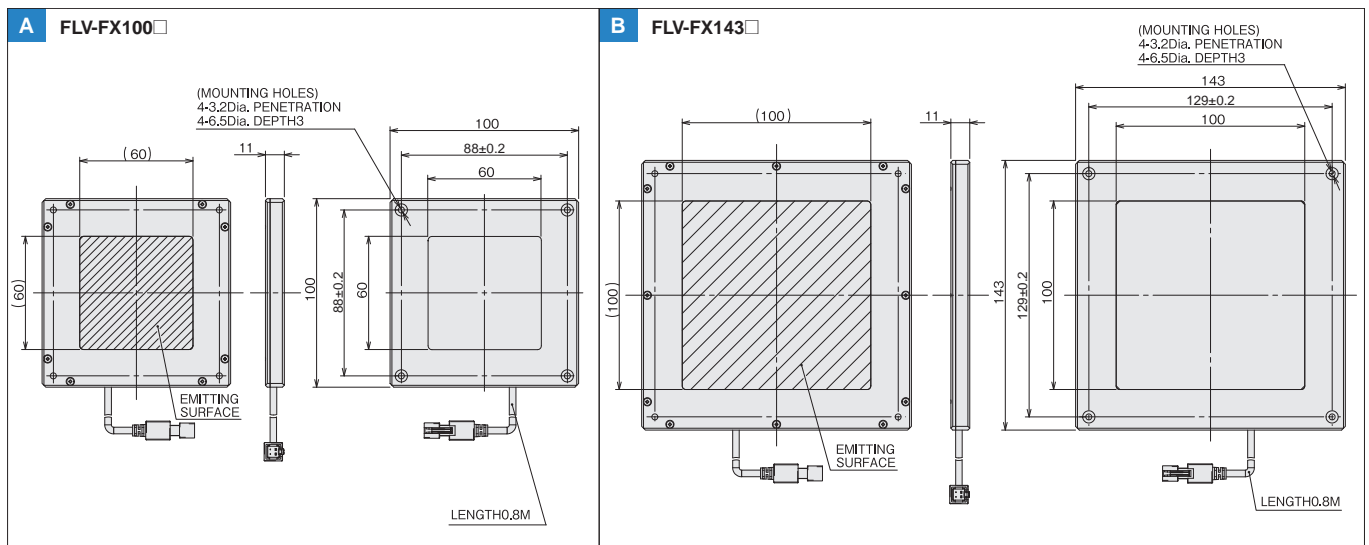

Dome Light FLV-DD Series

Uniform Illumination from All Directions
This series produces shadowless images of the entire workpiece.



Product Features

- Achieves uniform illumination by reflecting light from a ring-shaped light source through a highly reflective, diffusion dome.

Cross-sectional Diagram

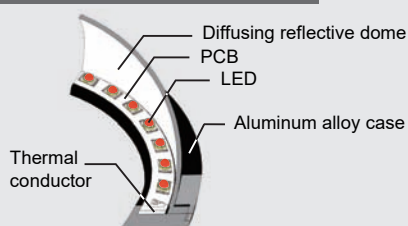
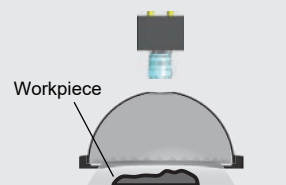

Illustration of Illumination



* This figure is a conceptual illustration and may vary from the actual structure.

Applications

Detection of characters and marks on curved or uneven surfaces

Detection of highly reflective surfaces, such as metal or glass

Shape measurements of curved or uneven workpieces

Inspection of Date Characters on Drink Cans



Detection of Characters on Cell Phones



Standard Models
FLV Series

High-brightness Models
FL Series

LED Characteristics

Lenses

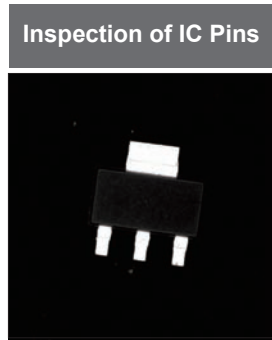
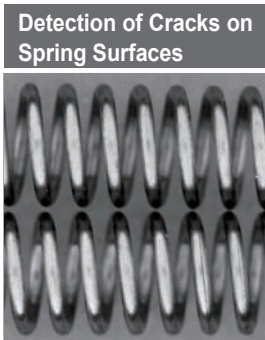

Ordering Information

Model	Color	Power consumption (W)	Dimensions				Controller *			Weight (g)
			Lighting Area Dimension (mm)	Outside Dimension (mm)	Height (mm)	Drawing	FLV-TCC□	FLV-ATC□	3Z4S-LT IDGB□	
FLV-DD70W	WHITE	2.3	45 dia.	70 dia.	31.74	A	○	○	○	130
FLV-DD70R	RED	1.4					○	○	○	
FLV-DD70B	BLUE	2.3					○	○	○	
FLV-DD100W	WHITE	17.9	65.6 dia.	114 dia.	56.28	B	×	○	○	210
FLV-DD100R	RED	11.9					○	○	○	
FLV-DD100B	BLUE	17.9					×	○	○	
FLV-DD150W	WHITE	17.9	116 dia.	175 dia.	83.21	C	×	○	○	490
FLV-DD150R	RED	11.9					○	○	○	
FLV-DD150B	BLUE	17.9					×	○	○	

* For the connectable Lighting Controller models and conditions, refer to the Specifications pages of each Lighting Controller.

FLV-TCC□: page 32 FLV-ATC□: page 38 3Z4S-LT IDGB□: page 45

Note: Refer to page 69 for LED Characteristics.

○: Connectable ×: Not connectable

Dimensions

(Unit: mm)

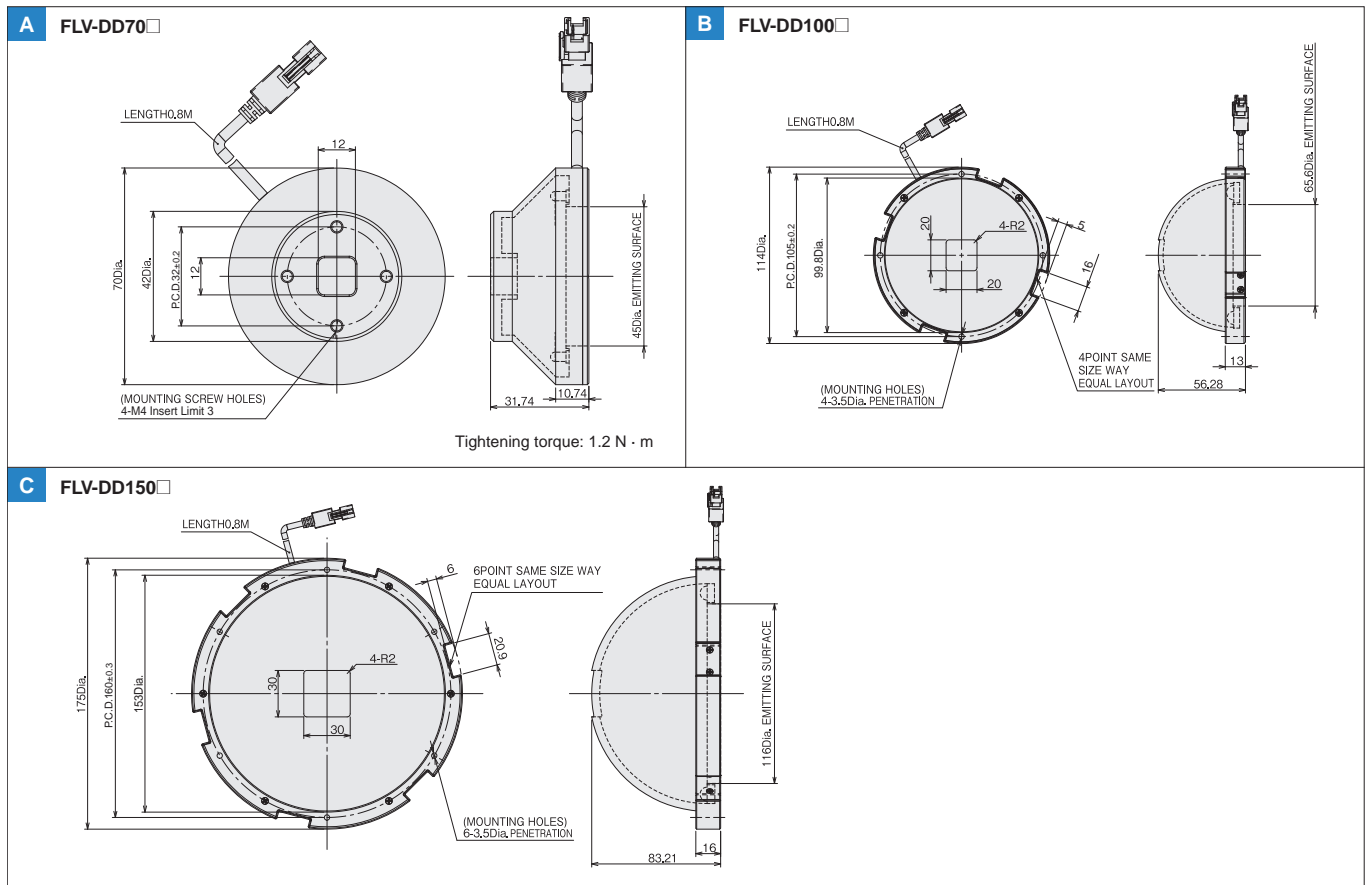

Line Light FLV-LN Series

Exceptionally Bright, Highly Uniform Line Lighting
This series is ideal for high-speed processing with line cameras.



Product Features

- Extremely high brightness
- Achieves highly effective line illumination with a condenser lens.

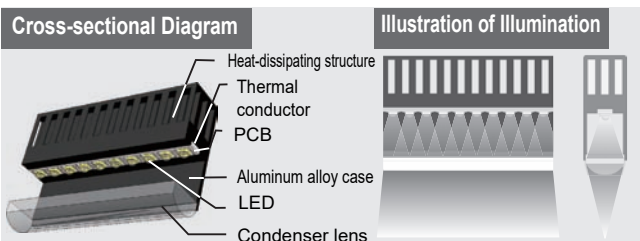

* This figure is a conceptual illustration and may vary from the actual structure.

Applications

Printing inspections

Sheet inspections

Detection of film and glass surface damage and internal impurities

Ordering Information

Model	Color	Power consumption (W)	Dimensions				Controller *			Weight (g)
			Lighting Area Dimension (mm)	Outside Dimension (mm)	Height (mm)	Drawing	FLV-TCC□	FLV-ATC□	3Z4S-LT IDGB□	
FLV-LN82W	WHITE	9.2	62×16	82×83.5	50	A	×	○	×	640
FLV-LN82B	BLUE	9.2					×	○	×	
FLV-LN122R	RED	10.4	102×16	122×83.5	50	E	×	○	×	800
FLV-LN142W	WHITE	18.4	122×16	142×83.5	50	B	×	○	×	890
FLV-LN142B	BLUE	18.4					×	○	×	
FLV-LN222R	RED	20.7	202×16	222×83.5	50	F	×	○	×	1320
FLV-LN322W	WHITE	45.9	302×16	322×83.5	50	C	×	○	×	1950
FLV-LN322	BLUE	45.9					×	○	×	
FLV-LN322R	RED	31.1					×	○	×	
FLV-LN442W	WHITE	64.3	442×16	442×83.5	50	D	×	○	×	2450
FLV-LN442B	BLUE	64.3					×	○	×	
FLV-LN442R	RED	41.4	402×16	422×83.5	50	H	×	○	×	2400

* For the connectable Lighting Controller models and conditions, refer to the Specifications pages of each Lighting Controller.

FLV-TCC□: page 32 FLV-ATC□: page 38 3Z4S-LT IDGB□: page 45

Note: Refer to page 69 for LED Characteristics.

○: Connectable ×: Not connectable

Dimensions

Standard Models
FLV Series

High-brightness Models
FL Series

LED Characteristics

Lenses

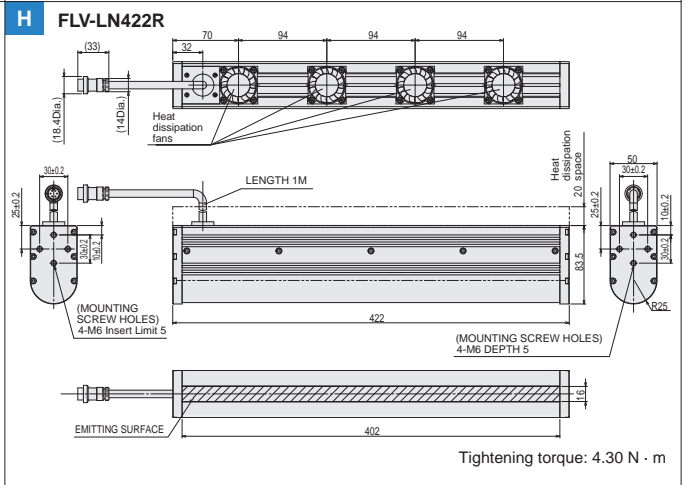
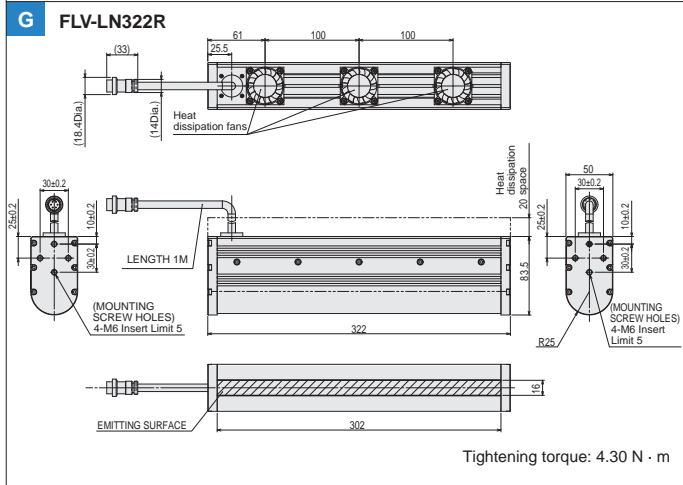
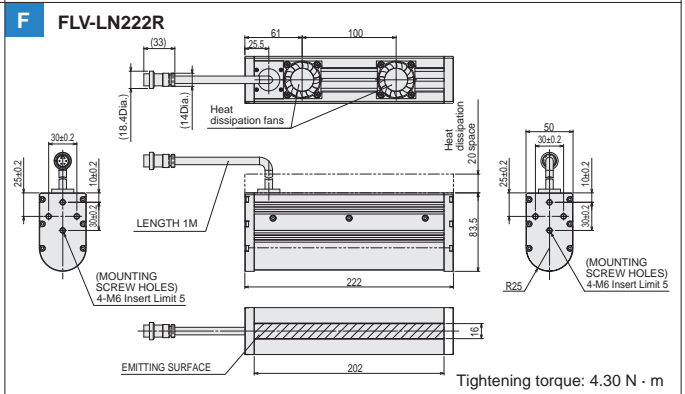
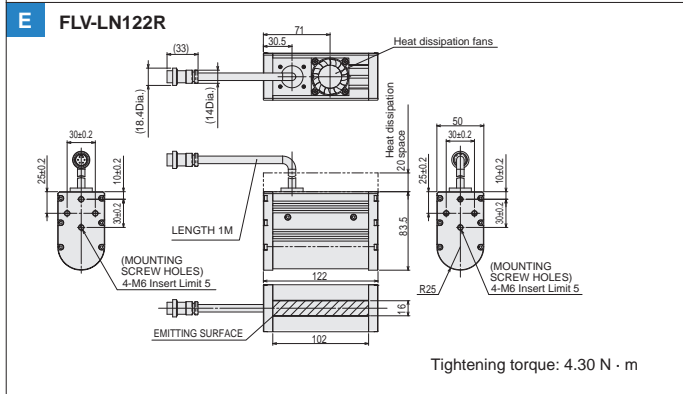
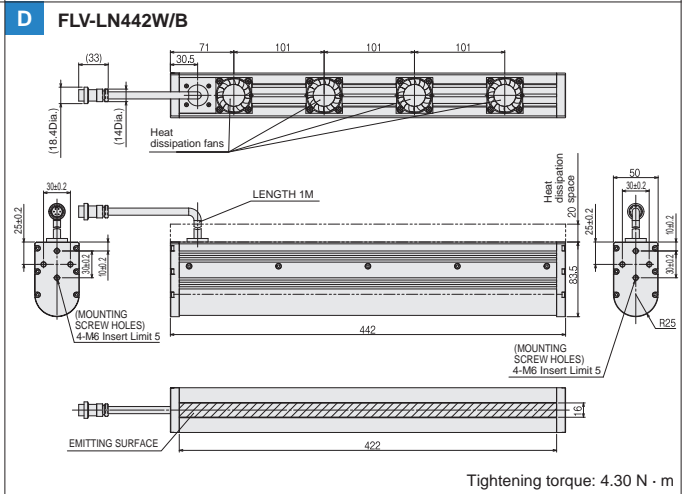
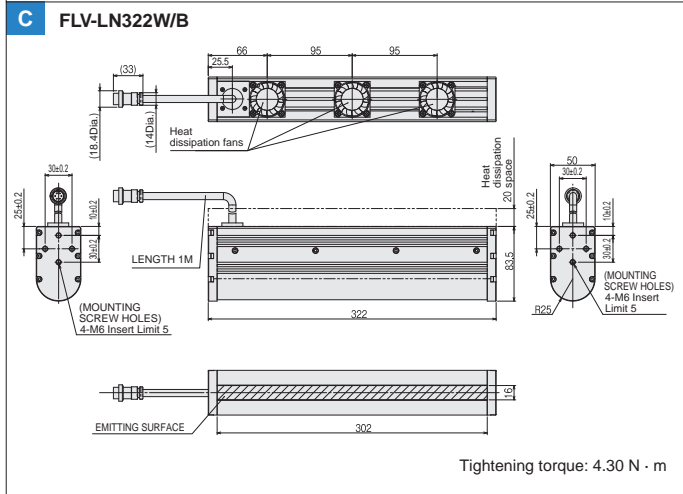
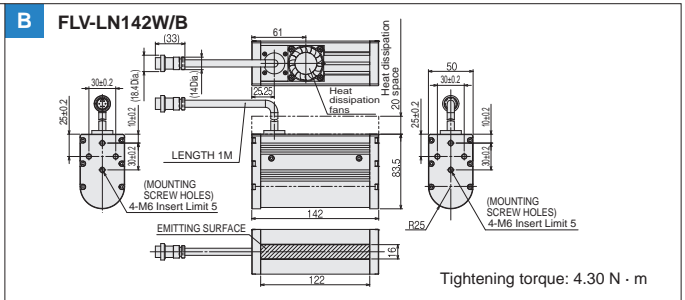
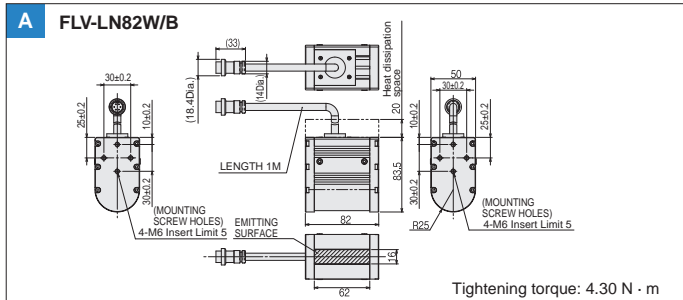

Camera-mount Lighting Controller for FLV Series

FLV-TCC Series

Standard Models
FLV Series

High-brightness Models
FL Series

Compact Lighting Controller
Mounts directly onto the FH/FZ
OMRON Cameras
Multistage Control of Lighting on
Up to Four Lights can be connected.



Product Features

- Saves space with its compact design.
- No need for space in control panels for expansion.
- Maintains Lighting intensity even when located at long distances.
- Light intensity and luminance control are set through the Vision System.

Simple wiring and space saving

Wiring from the control panel to remote Cameras and Lights is simplified.

The more Cameras and Lights are connected to the Vision System Controller, the more effective in simplifying wiring and saving space.

LED Characteristics

Lenses

Standard Lighting System

- Complicated wiring from the control panel to the Lights and Camera is required.
- Space to install the Power Supply for Lights in the control panel is required.

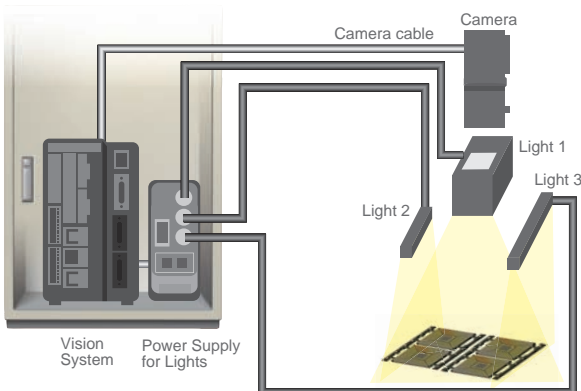

Camera cable + lighting cables are wired from control panel

FLV-TCC Series

- Power supplied from the Camera eliminates the need for complicated wiring from the control panel to the Lights.
- The compact design that enables mounting onto the Camera saves space in the control panel.

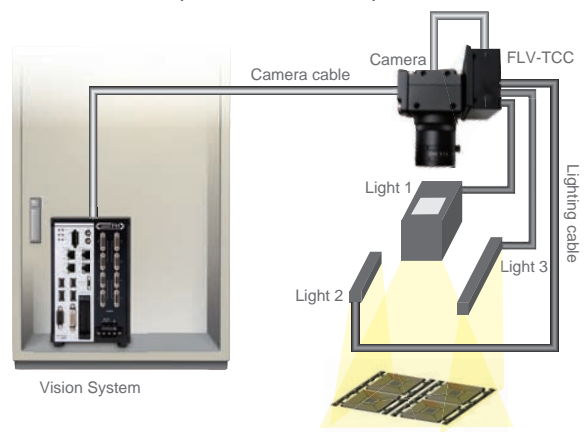

Only the camera cable is connected from control panel

Easy control setting

Light intensity and luminance control can be set from the flow menu of the Vision System Controller. No need of ladder programming to create light sequence or communications settings.

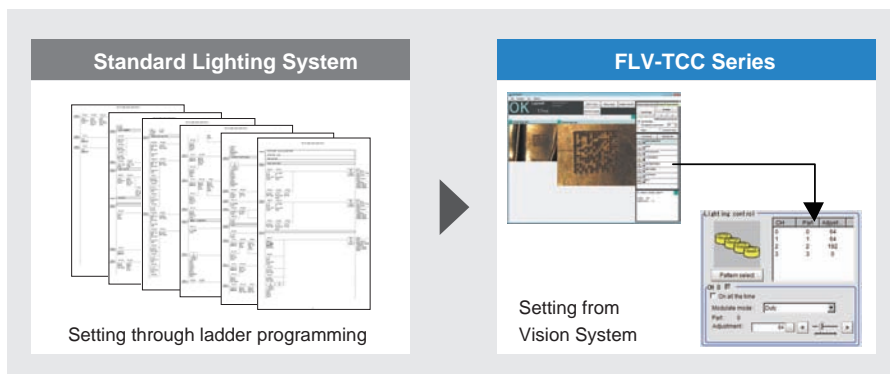

Maintaining light intensity even with long wiring distances

Even if the Vision System Controller and Light are separated by a long distance, the light intensity is maintained due to power being supplied through the Camera. This means that it is not required to increase light intensity and power consumption for high-speed production lines.

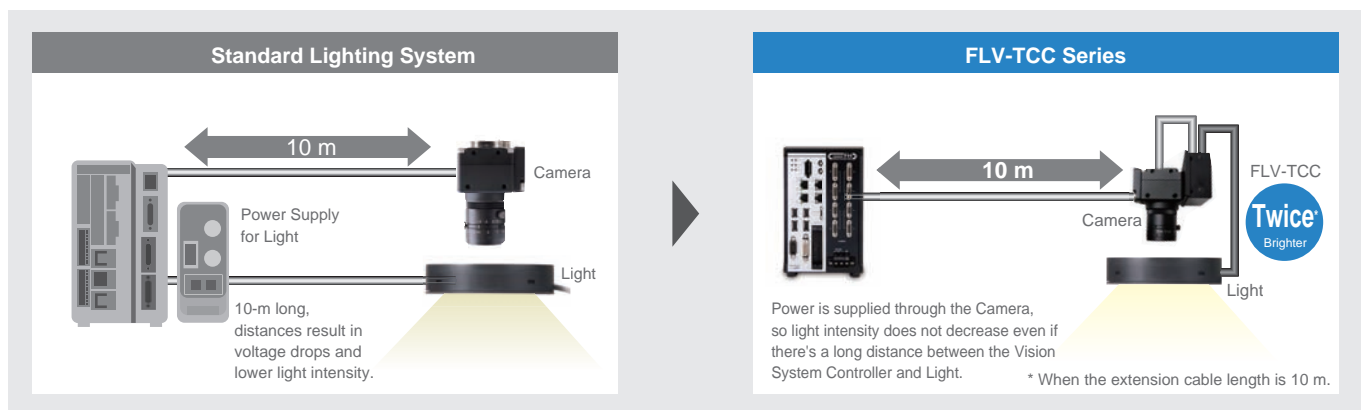

Connecting Spot Light

The new FLV-TCC□EP can be connected with a Spot Light, and the hybrid type FLV-TCC□HB can be connected with up to two Standard Lights and a Spot Light. Applications such as alignment and cosmetic inspection of small electronic parts, e.g. connectors and IC's, require these kind of Lighting Controllers using Spot Lights.

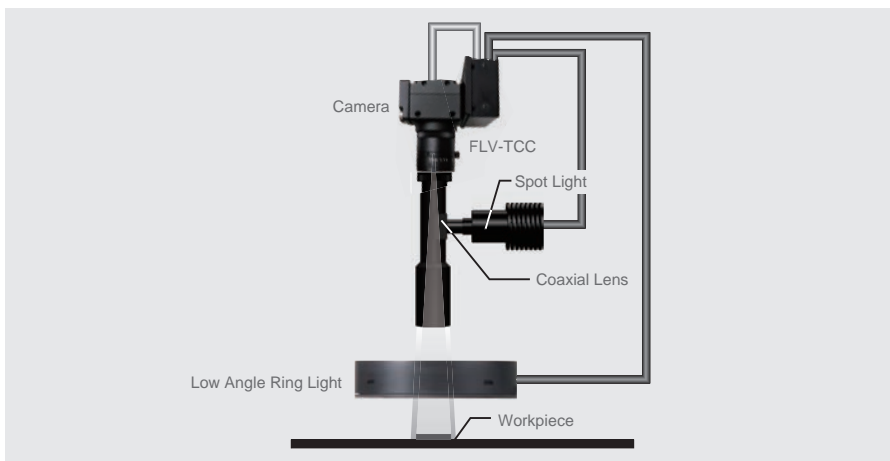

Ordering Information

Model	Number of Channels	Applicable Light *5			Power Supply Voltage	Power of Connected Light	Luminance Control Method
		Standard Light FLV Series*1	Spot Light FLV-EP Series	Line Light FLV-LN Series			
FLV-TCC4	4 standard lights	○	×	×	24 VDC *2	15 W max.*3	Digital *4
FLV-TCC1	1 standard light	○	×	×			
FLV-TCC3HB	1 Spot Light and 2 standard lights	○	○	×			
FLV-TCC1EP	1 Spot Light	×	○	×	—	Any FLV-EP-series Spot Light can be connected	

*1. Standard light means all FLV-series Lights excluding the FLV-EP-series Spot Lights and the FLV-LN-series Line Lights.
 *2. If the total power consumption of Lights is 7.5 W or less, an external power supply is not required because the power is supplied from the Camera.
 *3. Refer to the Specifications on page 34 for the details of "power for connectable lighting".
 *4. Intensity is controlled through the settings of the Vision System Controller.
 *5. ○: Connectable ×: Not connectable

Camera-mount Lighting Controller for FLV Series FLV-TCC Series

Specifications

Item	Model	FLV-TCC4	FLV-TCC1	FLV-TCC3HB	FLV-TCC1EP			
Number of channels		4 standard lights	1 standard light	1 Spot Light, 2 standard lights	1 Spot Light			
Applicable light *1		FLV series (excluding FLV-EP series and FLV-LN series)		FLV series (excluding FLV-LN series)	FLV-EP series			
Applicable camera *2		FH-S series, FZ-S series						
Applicable vision system controller		FH series						
Input voltage		Supplied from applicable camera (12 V) or external power supply (24 V) *3			Supplied from applicable camera (12 V)			
External power supply voltage		24 VDC 10% (including ripple)			—			
Current consumption		1.5A max.			1.0A max.			
	Recommended power supply	S8VS-06024 (manufactured by OMRON, 24 VDC, 2.5 A, 60 W)			—			
Power of connected light	12 VDC for camera supply	Continuous lighting		4ch total 7.5 W max.	7.5 W max.	0ch connection: 1,2ch total 5.5 W max. 0ch non-connection: 1,2ch total 7.5 W max.	All FLV-EP series can be connected.	
		Trigger lighting	Simultaneous lighting	4ch total 7.5 W max.	7.5 W max.			0ch connection: 1,2ch total 5.5 W max. 0ch non-connection: 1,2ch total 7.5 W max.
			Individual lighting	7.5 W max. for 1ch				7.5 W max. for 1ch
	24 VDC for external supply	Continuous lighting		4ch total 7.5 W max.	7.5 W max.	0ch connection: 1,2ch total 5.5 W max. 0ch non-connection: 1,2ch total 7.5 W max.		—
		Trigger lighting	Simultaneous lighting	4ch total 15 W max.	15 W max.	0ch connection: 1,2ch total 14 W max. 0ch non-connection: 1,2ch total 15 W max.		
			Individual lighting	15 W max. for 1ch		15 W max. for 1ch		
Drive method		Constant voltage method			0ch Constant current method 1ch/2ch: Constant voltage method	Constant current method		
Lighting method		Trigger lighting, Continuous lighting						
Luminance control method		Duty light adjustment or voltage light adjustment Duty light adjustment: PWM frequency of 100 kHz, light adjustment of 255 levels Voltage light adjustment: Light adjustment of 255 levels (all are configured with vision system controller)			0ch Duty light adjustment or current light adjustment 1ch/2ch Duty light adjustment or voltage light adjustment Duty light adjustment: PWM frequency of 100 kHz, light adjustment of 255 levels current light adjustment/ Voltage light adjustment: Light adjustment of 255 levels (all are configured with vision system controller)	Duty light adjustment or current light adjustment Duty light adjustment: PWM frequency of 100 kHz, light adjustment of 255 levels current light adjustment: Light adjustment of 255 levels (all are configured with vision system controller)		
Trigger lighting		Lighting in synchronization with trigger input timing from the controller.						
Trigger lighting delay time		Ton: 30μs max.						
Lighting duration setting		Auto setting in accordance with shutter speed.						
External interface		Camera connection cable (directly connected with the main unit)						
Insulation resistance		0.5 MΩ (100VDC)						
Ambient temperature		Operating: 0 to +50°C, Storage: -15 to +60°C (with no icing or condensation)						
Ambient humidity		Operating and storage: 35% to 85% (with no condensation)						
Degree of protection		IP20 (IEC60529)						
Vibration resistance (destructive)		10 to 150 Hz, (0.7mm double amplitude) 80 min each in X, Y, and Z directions						
Shock resistance (destructive)		150 m/s ² 3 times each in 6 directions(up/down, left/right, forward/backward)						
Materials		Case, Camera mount plate: Aluminum, Cable: FPVC						
Weight		Approx. 130g (including the camera mount plate)	Approx. 120g (including the camera mount plate)	Approx. 130g (including the camera mount plate)	Approx. 120g (including the camera mount plate)			
Accessories		Instruction sheet, Lighting connection table, Camera Mount plate, Mounting screws (M2 set screw x 4, M2 flat head screw x 4, M4 flat head screw x 4)						
Applicable standards		EN61326-1 *4, KC						

*1. Check the lighting connection table of accessory.

*2. When mounting on the FH-S□12, use the FH-SM12-XLC (sold separately).

*3. When supplying the power to this product from an external input power supply (24V), make sure to turn ON the power to this product first or at the same time with the vision system controller. If you reverse this order, this product will not recognize the 24V external input, so lighting greater than 7.5W will not be possible.

*4. Electromagnetic environment: Industrial electromagnetic environment (EN/IEC 61326-1 Table 2)

Also, the following condition is applied to the immunity test of this product.

There are case that Lighting brightness fluctuate Max 10%.

Camera-mount Lighting Controller for FLV Series FLV-TCC Series

FLV Light Connection Table

Lighting controllers that can be connected to each light are shown below.

○: Connectable, continuous lighting possible ○: Connectable, only trigger lighting possible ×: Not connectable

The following table shows if you can connect one light to each lighting controller.

When connecting lights to multiple channels, make sure that the total power consumption of the connected lights is within the specification of the lighting controller.

Direct Ring Light

Model	Power consumption	FLV-TCC4□ FLV-TCC1□	FLV-TCC3HB□ *1	
			0ch non-connection	0ch connection
FLV-DR3220W	1.4W	○	○	○
FLV-DR3220R	1.3W	○	○	○
FLV-DR3220B	1.4W	○	○	○
FLV-DR4415W	2.7W	○	○	○
FLV-DR4415R	1.7W	○	○	○
FLV-DR4415B	2.7W	○	○	○
FLV-DR5030W	3.1W	○	○	○
FLV-DR5030R	1.8W	○	○	○
FLV-DR5030B	3.1W	○	○	○
FLV-DR5030IR	1.3W	○	○	○
FLV-DR6030UV	3.2W	○	○	○
FLV-DR6615W	5.0W	○	○	○
FLV-DR6615R	3.9W	○	○	○
FLV-DR6615B	5.0W	○	○	○
FLV-DR7000W	5.0W	○	○	○
FLV-DR7000R	3.7W	○	○	○
FLV-DR7000B	5.0W	○	○	○
FLV-DR7030W	5.0W	○	○	○
FLV-DR7030R	3.7W	○	○	○
FLV-DR7030B	5.0W	○	○	○
FLV-DR7030IR	2.6W	○	○	○
FLV-DR7530UV	5.4W	○	○	○
FLV-DR9000W	8.8W	○	○	○
FLV-DR9000R	7.0W	○	○	○
FLV-DR9000B	8.8W	○	○	○
FLV-DR9030W	8.1W	○	○	○
FLV-DR9030R	6.6W	○	○	○
FLV-DR9030B	8.1W	○	○	○
FLV-DR9030IR	4.3W	○	○	○
FLV-DR9030UV	6.8W	○	○	○
FLV-DR9215W	7.4W	○	○	○
FLV-DR9215R	5.4W	○	○	○
FLV-DR9215B	7.4W	○	○	○
FLV-DR12030W	11.9W	○	○	○
FLV-DR12030R	9.8W	○	○	○
FLV-DR12030B	11.9W	○	○	○

*1.0ch is only for Spot Light.

Low Angle Ring Light

Model	Power consumption	FLV-TCC4□ FLV-TCC1□	FLV-TCC3HB□	
			0ch non-connection	0ch connection
FLV-DL5890W	1.9W	○	○	○
FLV-DL5890R	1.3W	○	○	○
FLV-DL5890B	1.9W	○	○	○
FLV-DL7260W	5.7W	○	○	○
FLV-DL7260R	3.9W	○	○	○
FLV-DL7260B	5.7W	○	○	○
FLV-DL9090W	2.8W	○	○	○
FLV-DL9090R	1.8W	○	○	○
FLV-DL9090B	2.8W	○	○	○
FLV-DL12060W	12.7W	○	○	○
FLV-DL12060R	10.5W	○	○	○
FLV-DL12060B	12.7W	○	○	○
FLV-DL15060W	13.6W	○	○	○
FLV-DL15060R	11.2W	○	○	○
FLV-DL15060B	13.6W	○	○	○

Bar Light

Model	Power consumption	FLV-TCC4□ FLV-TCC1□	FLV-TCC3HB□	
			0ch non-connection	0ch connection
FLV-BR6022W	1.4W	○	○	○
FLV-BR6022R	1.3W	○	○	○
FLV-BR6022B	1.4W	○	○	○
FLV-BR6022IR	0.9W	○	○	○
FLV-BR6424UV	1.8W	○	○	○
FLV-BR8532W	3.5W	○	○	○
FLV-BR8532R	3.1W	○	○	○
FLV-BR8532B	3.5W	○	○	○
FLV-BR11222W	4.2W	○	○	○
FLV-BR11222R	2.6W	○	○	○
FLV-BR11222B	4.2W	○	○	○
FLV-BR11222IR	1.8W	○	○	○
FLV-BR11624UV	3.6W	○	○	○
FLV-BR14030W	6.1W	○	○	○
FLV-BR14030R	4.8W	○	○	○
FLV-BR14030B	6.1W	○	○	○
FLV-BR15020W	5.5W	○	○	○
FLV-BR15020R	3.1W	○	○	○
FLV-BR15020B	5.5W	○	○	○
FLV-BR21222W	8.7W	○	○	○
FLV-BR21222R	5.0W	○	○	○
FLV-BR21222B	8.7W	○	○	○
FLV-BR21230W	8.8W	○	○	○
FLV-BR21230R	7.0W	○	○	○
FLV-BR21230B	8.8W	○	○	○
FLV-BR21230IR	6.1W	○	○	○
FLV-BR21230UV	7.8W	○	○	○
FLV-BR38037W	15.9W	×	×	×
FLV-BR38037R	11.3W	○	○	○
FLV-BR38037B	15.9W	×	×	×
FLV-BR48031W	21.9W	×	×	×
FLV-BR48031R	18.0W	×	×	×
FLV-BR48031B	21.9W	×	×	×

Coaxial Light

Model	Power consumption	FLV-TCC4□ FLV-TCC1□	FLV-TCC3HB□	
			0ch non-connection	0ch connection
FLV-CL30W	2.4W	○	○	○
FLV-CL30R	1.4W	○	○	○
FLV-CL30B	2.4W	○	○	○
FLV-CL40W	3.9W	○	○	○
FLV-CL40R	2.3W	○	○	○
FLV-CL40B	3.9W	○	○	○
FLV-CL60W	10.4W	○	○	○
FLV-CL60R	5.7W	○	○	○
FLV-CL60B	10.4W	○	○	○
FLV-CL60IR	3.9W	○	○	○
FLV-CL60UV	3.0W	○	○	○
FLV-CL80W	10.8W	○	○	○
FLV-CL80R	7.2W	○	○	○
FLV-CL80B	10.8W	○	○	○
FLV-CL100W	22.7W	×	×	×
FLV-CL100R	15.2W	×	×	×
FLV-CL100B	22.7W	×	×	×

Camera-mount Lighting Controller for FLV Series FLV-TCC Series

Shadowless Light

Model	Power consumption	FLV-TCC4□ FLV-TCC1□	FLV-TCC3HB□	
			0ch non-connection	0ch connection
FLV-FR114W	3.9W	○	○	○
FLV-FR114R	3.1W	○	○	○
FLV-FR114B	3.9W	○	○	○
FLV-FR150W	6.1W	○	○	○
FLV-FR150R	3.5W	○	○	○
FLV-FR150B	6.1W	○	○	○
FLV-FP130W	8.1W	○	○	○
FLV-FP130R	5.8W	○	○	○
FLV-FP130B	8.1W	○	○	○
FLV-FS74W	5.2W	○	○	○
FLV-FS74R	3.5W	○	○	○
FLV-FS74B	5.2W	○	○	○
FLV-FQ48W	2.0W	○	○	○
FLV-FQ48R	1.2W	○	○	○
FLV-FQ48B	2.0W	○	○	○

Direct Back Light

Model	Power consumption	FLV-TCC4□ FLV-TCC1□	FLV-TCC3HB□	
			0ch non-connection	0ch connection
FLV-DB3729W	0.9W	○	○	○
FLV-DB3729R	0.9W	○	○	○
FLV-DB3729B	0.9W	○	○	○
FLV-DB10181W	8.1W	○	○	○
FLV-DB10181R	4.7W	○	○	○
FLV-DB10181B	8.1W	○	○	○
FLV-DB130130W	13.0W	○	○	○
FLV-DB130130R	11.5W	○	○	○
FLV-DB130130B	13.0W	○	○	○
FLV-DB212152W	29.4W	×	×	×
FLV-DB212152R	20.2W	×	×	×
FLV-DB212152B	29.4W	×	×	×

Edge Type Light

Model	Power consumption	FLV-TCC4□ FLV-TCC1□	FLV-TCC3HB□	
			0ch non-connection	0ch connection
FLV-FB5050W	1.9W	○	○	○
FLV-FB5050R	1.0W	○	○	○
FLV-FB5050B	1.9W	○	○	○
FLV-FB7070W	1.9W	○	○	○
FLV-FB7070R	1.4W	○	○	○
FLV-FB7070B	1.9W	○	○	○
FLV-FB9090W	3.7W	○	○	○
FLV-FB9090R	1.9W	○	○	○
FLV-FB9090B	3.7W	○	○	○
FLV-FB130130W	5.5W	○	○	○
FLV-FB130130R	3.7W	○	○	○
FLV-FB130130B	5.5W	○	○	○
FLV-FB200200W	7.3W	○	○	○
FLV-FB200200R	5.5W	○	○	○
FLV-FB200200B	7.3W	○	○	○

Edge Type Coaxial Light

Model	Power consumption	FLV-TCC4□ FLV-TCC1□	FLV-TCC3HB□	
			0ch non-connection	0ch connection
FLV-FX100W	3.7W	○	○	○
FLV-FX100R	1.9W	○	○	○
FLV-FX100B	3.7W	○	○	○
FLV-FX143W	5.5W	○	○	○
FLV-FX143R	3.7W	○	○	○
FLV-FX143B	5.5W	○	○	○

Dome Light

Model	Power consumption	FLV-TCC4□ FLV-TCC1□	FLV-TCC3HB□	
			0ch non-connection	0ch connection
FLV-DD70W	2.3W	○	○	○
FLV-DD70R	1.4W	○	○	○
FLV-DD70B	2.3W	○	○	○
FLV-DD100W	17.9W	×	×	×
FLV-DD100R	11.9W	○	○	○
FLV-DD100B	17.9W	×	×	×
FLV-DD150W	17.9W	×	×	×
FLV-DD150R	11.9W	○	○	○
FLV-DD150B	17.9W	×	×	×

Spot Light

Model	Power consumption	FLV-TCC3HB□ FLV-TCC1EP□
FLV-EP0803W	1.6W	○
FLV-EP0803R	1.1W	○
FLV-EP0803B	1.6W	○
FLV-EP50W	1.6W	○
FLV-EP50R	1.1W	○

Line Light

Model	Power consumption
FLV-LN82W	9.2W
FLV-LN142W	18.4W
FLV-LN322W	45.9W
FLV-LN442W	64.3W
FLV-LN122R	10.4W
FLV-LN222R	20.7W
FLV-LN322R	31.1W
FLV-LN422R	41.4W
FLV-LN82B	9.2W
FLV-LN142B	18.4W
FLV-LN322B	45.9W
FLV-LN442B	64.3W

Part Names and Functions

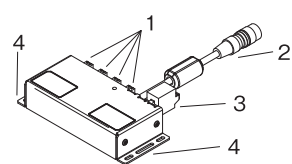

No.	Name	Description
1	Lighting connecting connector	Connects to the LED lighting.
2	Camera connecting cable	Connects to the extension connector of the camera.
3	24 V external power supply input terminal block *	Connect a 24-VDC power supply if the total power consumption of the Lightings exceeds 7.5 W.
4	Mounting hole for fixing screw	Holes to mount the screws to secure the Lighting Controller to a mounting plate or device.

* To wire the terminal block, connect a applicable cord (AWG12-26 with a 10 mm margin for work).

Mounting the Controller to the Camera

The Lighting Controller can be mounted to the Camera using the provided camera mount plate. Mounting directions are: (1) Top/Bottom mount, (2) Right side mount, (3) Left side mount.

(1) Top/Bottom mount

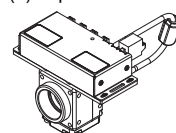

(2) Right side mount

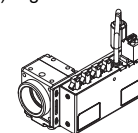

(3) Left side mount

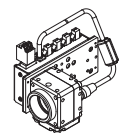

Camera-mount Lighting Controller for FLV Series FLV-TCC Series

Dimensions

(Unit: mm)

Lighting Controller

FLV-TCC4

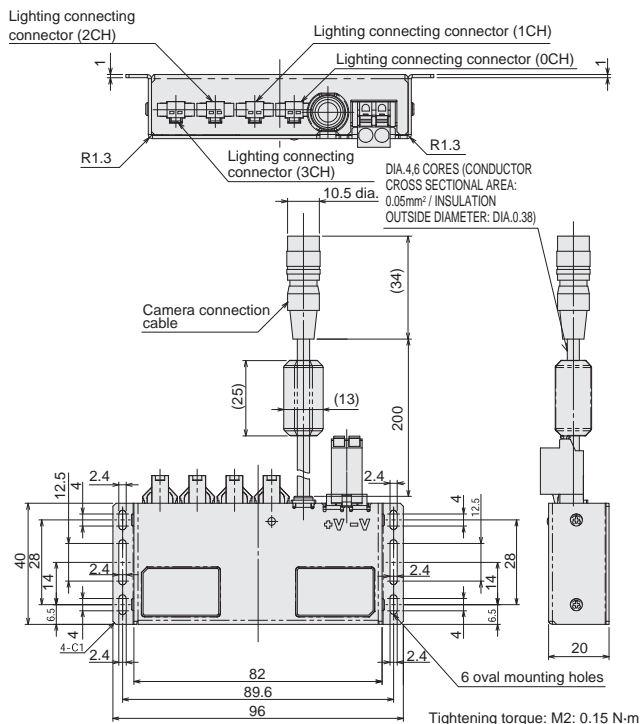

FLV-TCC1

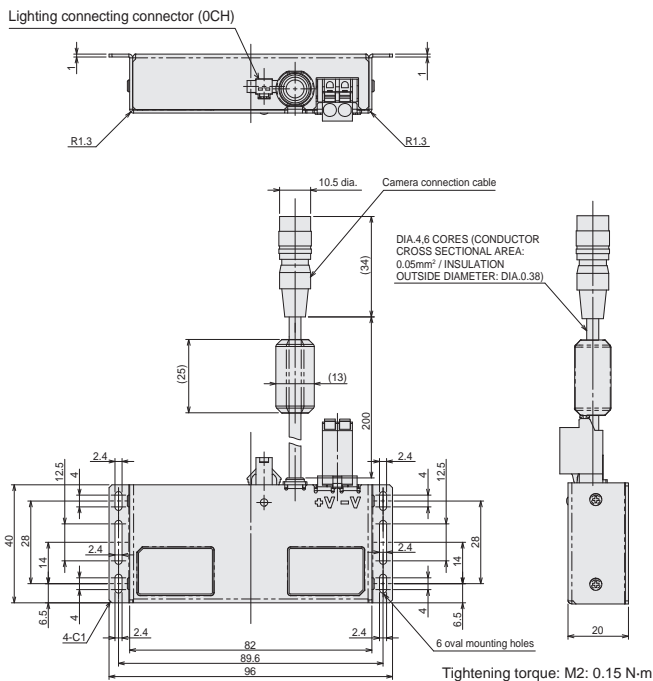

FLV-TCC3HB

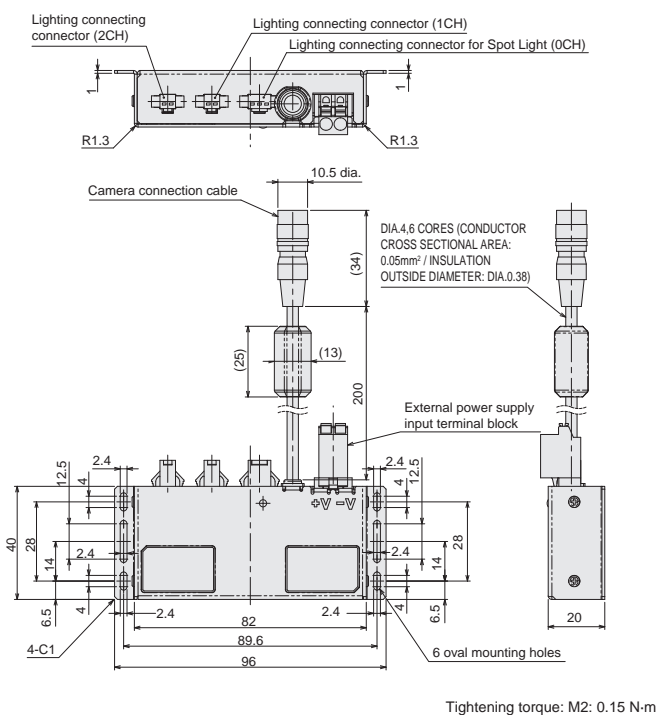

FLV-TCC1EP

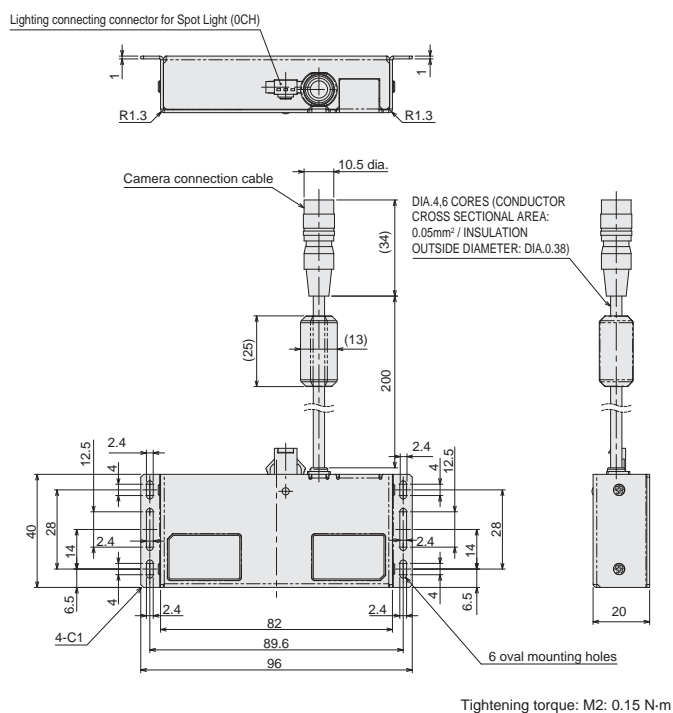

Camera mount plate (provided)

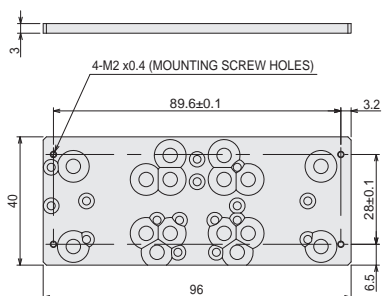

Standard Models
FLV Series

High-brightness Models
FL Series

LED Characteristics

Lenses

Analog Lighting Controller for FLV Series

FLV-ATC Series

Stationary Lighting Controller.



Product Features

- Stationary type suitable for separate installation when no space near the Camera.
- Light emission trigger can be input directly even without Vision Sensor.

Ordering Information

Applicable light	Model	Number of channels	Power supply voltage	Power of connected light	Luminance control method
For standard light *1	FLV-ATC21024 *2	2	100 to 240 VAC, 50/60 Hz	40 W max.	Analog
	FLV-ATC41024 *2	4		3 W max.	
For spot light	FLV-ATC10405 *2	1		12 W max.	
	FLV-ATC40405 *2	4		240 W max.	
For line light	FLV-ATC26024-100V *2	2	100 to 120 VAC, 50/60 Hz	240 W max.	
	FLV-ATC26024-200V	2	200 to 240 VAC, 50/60 Hz		

*1. Standard Light means all FLV-series Lights excluding the FLV-EP-series Spot Lights and the FLV-LN-series Line Lights.

*2. For AC power cords: An A-type plug is standard. C-type and O-type plugs are also available. (Add "-C" or "-O" to the end of the model number.)

Plug type	A	C	O
Rated voltage	125 V	240 V	240 V
Standard	PSE	CEE	CCC

AC Power Cords with A-type Plugs

WARNING

The cable included in this package can be applied only to 100 VAC commercial power in Japan. You can not use it in the country outside Japan. Please never use it on the voltage beyond 100 VAC. It becomes a cause of ignition, generation of heat, and failure.



Lighting Controller for Standard Light FLV-ATC21024/-ATC41024

Part Names and Functions

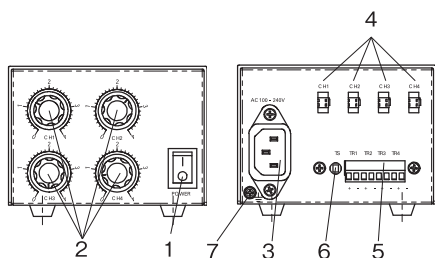

No.	Name	Description
1	Main power supply	Starts up the Controller when it is turned ON.
2	Lighting adjustment volume	Rotating the volume clockwise increases the emission intensity or counterclockwise decreases it.
3	AC power supply input connector	A terminal to supply AC power. Connect the provided AC input cable.
4	Lighting connector	Connects an LED light.
5	Trigger input terminal block	A terminal block for lighting illumination trigger input from outside to each lighting.
6	Lighting mode switching button	Lighting mode switch button is ON (The button is pushed.): Short-circuiting (+) and (-) of TR1 to TR4 respectively makes the trigger input status ON, turning the light ON. Releasing (+) and (-) makes the status OFF, turning the light OFF. Lighting mode switch button is OFF (The button is not pushed.): Short-circuit (+) and (-) of TR1 to TR4 respectively makes the trigger input status OFF, turning the light OFF. Releasing (+) and (-) makes the status ON, turning the light ON.
7	Frame ground terminal	A terminal for frame ground. Connect the ground line.

Specifications

Item	Model	FLV-ATC21024-□ *1	FLV-ATC41024-□ *1
Number of channels		2	4
Applicable light		FLV series (FLV-EP series and FLV-LN series are excluded.)	
Power supply voltage *2		100 to 240 VAC, 50/60 Hz	
Current consumption		1 A max.	
Power of connected light		2ch total 40 W max. 30 W max. for 1ch	4ch total 40 W max. 30 W max. for 1ch
Drive method		Constant voltage method	
Lighting method		Trigger lighting, Continuous lighting	
Luminance control method		Voltage light adjustment: 14.0 to 24.0 V	
Trigger lighting		Lighting in synchronization with input from the trigger input terminal	
Trigger lighting delay time		T _{on} : 100 μs max.	
External interface		Trigger input terminal block	
Dielectric strength		1500 VAC 50/60 Hz 1 min	
Insulation resistance		20 MΩ (500 VDC)	
Ambient temperature		Operating: 0 to 50°C, Storage: -15 to 60°C (with no icing or condensation)	
Ambient humidity		Operating/storage: 35% to 85% (with no condensation)	
Degree of protection		IP20 (IEC60529)	
Vibration resistance (destructive)		10 to 150 Hz, (0.2 mm double amplitude) 80 min each in X, Y, and Z directions	
Shock resistance (destructive)		150 m/s ² 3 times each in 6 directions (up/down, left/right, forward/backward)	
Materials		Case: Aluminum	
Weight		Approx. 800 g	
Accessories		Instruction sheet, AC input cable *1	
Applicable standards		EN61326-1 *3	

*1. The suffixed symbol of the model name means the plug type of the accessory cable. A model name with no suffix means type A.

*2. This product is the exclusive use for apparatus inclusion in the industrial machine field.

This product cannot be used for the connection to electric power equipment, such as a common residence, store, and small establishment, because of nonconformity with to Electrical Appliance and Material Safety Law (PSE).

*3. Electromagnetic environment: Industrial electromagnetic environment (EN/IEC 61326-1 Table 2)

Also, the following condition is applied to the immunity test of this product.

There are case that Lighting brightness fluctuate Max 10%.

Analog Lighting Controller for FLV Series FLV-ATC Series

Connecting to External Trigger Input Terminal Block

• Connection of this terminal block is not required if lighting illumination trigger input from outside is not used.

<Connection of trigger input terminal block>

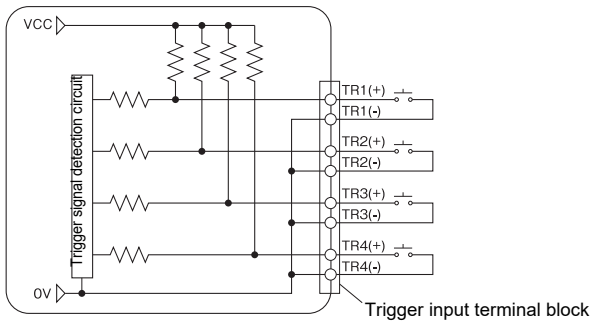

* Current flowing through the short circuit is less than 2 mA.

FLV-ATC21024-□

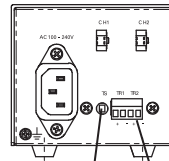

Lighting mode switch button

Trigger input terminal block CH1 to CH2

FLV-ATC41024-□

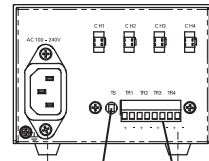

Lighting mode switch button

Trigger input terminal block CH1 to CH4

Lighting mode switch button is ON (The button is pushed.)

Short-circuiting (+) and (-) of TR1 to TR4 respectively makes the trigger input status ON, turning the light ON.

Releasing (+) and (-) makes the status OFF, turning the light OFF.

Lighting mode switch button is OFF (The button is not pushed.)

Short-circuit (+) and (-) of TR1 to TR4 respectively makes the trigger input status OFF, turning the light OFF.

Releasing (+) and (-) makes the status ON, turning the light ON.

[Important]

Make sure that excessive force is not imposed on the wire and terminal block.

Do not install the product in which loads are constantly applied to the terminal block such as the wire being under tension.

When wiring the terminal block, use an applicable cable (AWG 14 to 24, tip processing length: 7 mm).

Dimensions

(Unit: mm)

●FLV-ATC21024-□

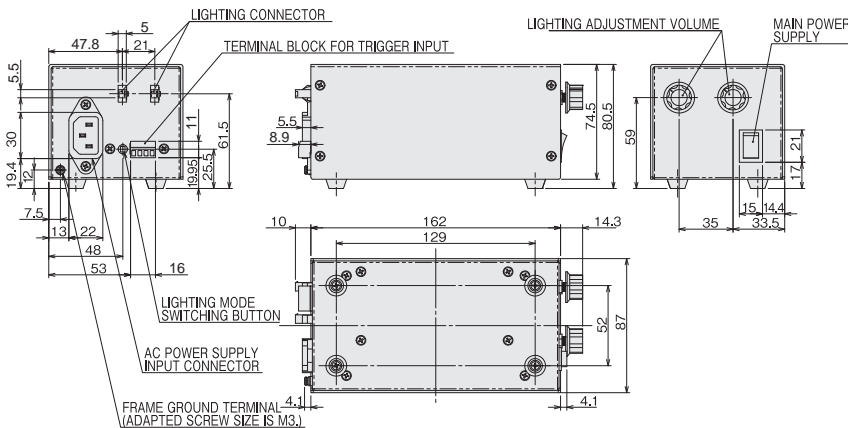

●FLV-ATC41024-□

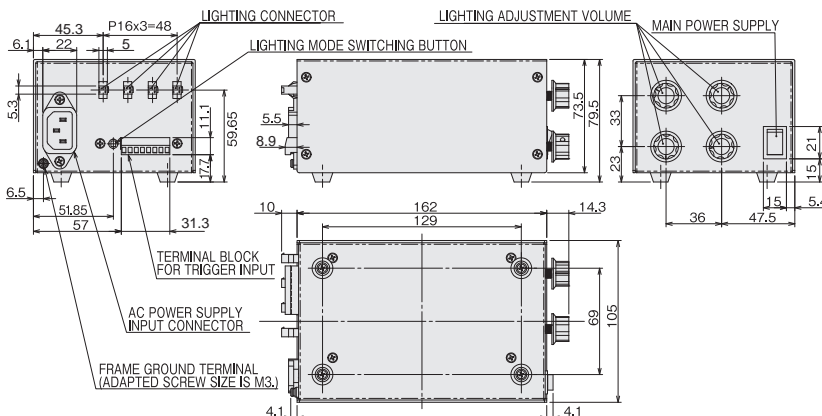

Lighting Controller for Spot Light FLV-ATC10405/-ATC40405

Part Names and Functions

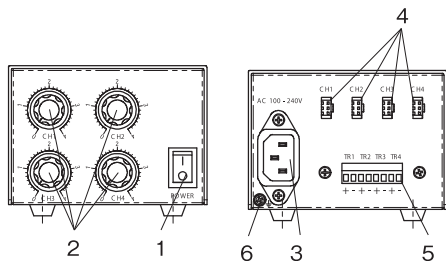

No.	Name	Description
1	Main power supply	Starts up the Controller when it is turned ON.
2	Lighting adjustment volume	Rotating the volume clockwise increases the emission intensity or counterclockwise decreases it.
3	AC power supply input connector	A terminal to supply AC power. Connect the provided AC input cable.
4	Lighting connector	Connects an LED lights.
5	Terminal block for trigger input	A terminal block for lighting illumination trigger input from outside to each lighting.
6	Frame ground terminal	A terminal for frame ground. Connect the ground line.

Specifications

Item	Model	FLV-ATC10405-□ *1	FLV-ATC40405-□ *1
Number of channels		1	4
Applicable light		FLV-EP series	
Power supply voltage *2		100 to 240 VAC, 50/60 Hz	
Current consumption		0.6 A max.	
Power of connected light		3 W max.	4ch total 12 W max. 3 W max. for 1ch
Drive method		Constant current method	
Lighting method		Trigger lighting, Continuous lighting	
Luminance control method		Current light adjustment : 0.4 A max.	
Trigger lighting		Turning the light off in synchronization with input from the trigger input terminal	
Trigger lighting delay time		T_on: 1000 μs max.	
External interface		Trigger input terminal block	
Dielectric strength		1500 VAC 50/60 Hz 1 min	
Insulation resistance		20 MΩ (500 VDC)	
Ambient temperature		Operating: 0 to 50°C, Storage: -15 to 60°C (with no icing or condensation)	
Ambient humidity		Operating/storage: 35% to 85% (with no condensation)	
Degree of protection		IP20 (IEC60529)	
Vibration resistance (destructive)		10 to 150 Hz, (0.2 mm double amplitude) 80 min each in X, Y, and Z directions	
Shock resistance (destructive)		150 m/s ² 3 times each in 6 directions (up/down, left/right, forward/backward)	
Materials		Case: Aluminum	
Weight		Approx. 800 g	
Accessories		Instruction sheet, AC input cable *1	
Applicable standards		EN61326-1 *3	

*1. The suffixed symbol of the model name means the plug type of the accessory cable. A model name with no suffix means type A.

*2. This product is the exclusive use for apparatus inclusion in the industrial machine field.
This product cannot be used for the connection to electric power equipment, such as a common residence, store, and small establishment, because of nonconformity with to Electrical Appliance and Material Safety Law (PSE).

*3. Electromagnetic environment: Industrial electromagnetic environment (EN/IEC 61326-1 Table 2)
Also, the following condition is applied to the immunity test of this product.
There are case that Lighting brightness fluctuate Max 10%.

Analog Lighting Controller for FLV Series FLV-ATC Series

Connecting to External Trigger Input Terminal Block

- Connection of this terminal block is not required if lighting illumination trigger input from outside is not used.

<Connection of trigger input terminal block>

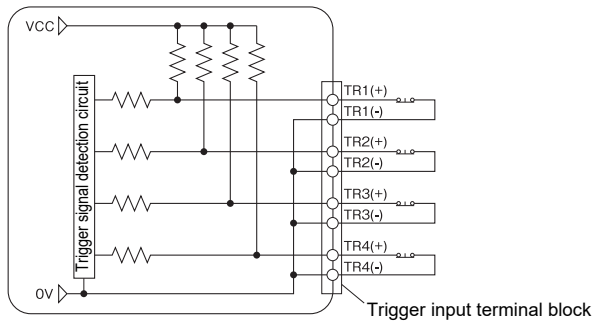

* Current flowing through the short circuit is less than 1 mA.

FLV-ATC10405-□

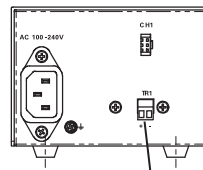

Trigger input terminal block CH1

FLV-ATC40405-□

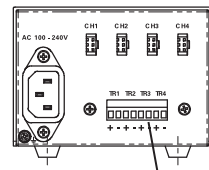

Trigger input terminal block CH1 to CH4

Short-circuiting (+) and (-) of TR1 to TR4 respectively makes the trigger input status OFF, turning the light OFF.
Releasing (+) and (-) makes the status ON, turning the light ON.

[Important]

- Make sure that excessive force is not imposed on the wire and terminal block.
- Do not install the product in which loads are constantly applied to the terminal block such as the wire being under tension.

When wiring the terminal block, use an applicable cable (AWG 14 to 24, tip processing length: 7 mm).

Dimensions

(Unit: mm)

●FLV-ATC10405-□

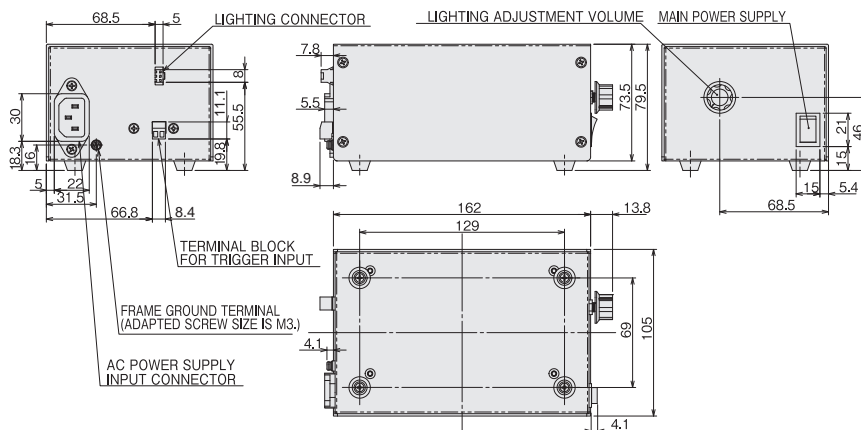

●FLV-ATC40405-□

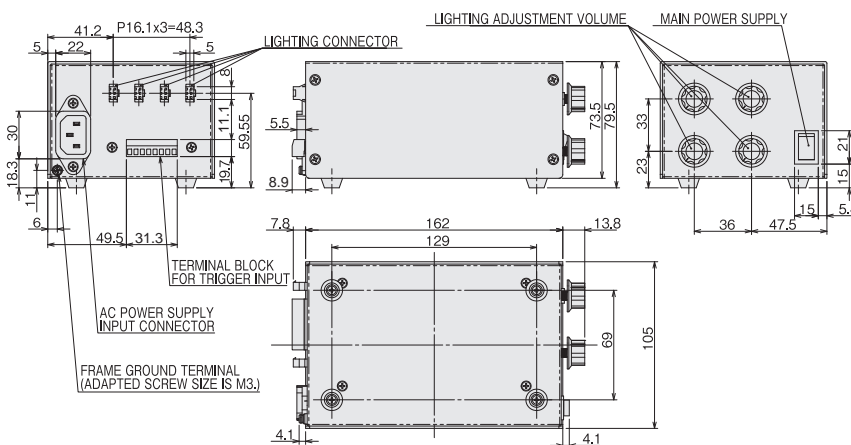

Lighting Controller for Line Light: FLV-ATC26024-100V/-200V

Part Names and Functions

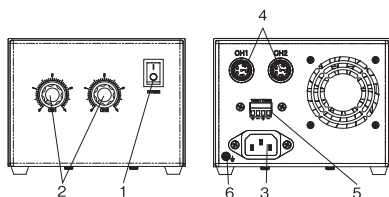

No.	Name	Description
1	Main power supply	Starts up the Controller when it is turned ON.
2	Lighting adjustment volume	Rotating the volume clockwise increases the emission intensity or counterclockwise decreases it.
3	AC power supply input connector	A terminal to supply AC power. Connect the provided AC input cable.
4	Lighting connector	Connects an LED lights.
5	Trigger input terminal block	A terminal block for lighting illumination trigger input from outside to each lighting.
6	Frame ground terminal	A terminal for frame ground. Connect the ground line.

Specifications

Item	Model	FLV-ATC26024-100V□ *1	FLV-ATC26024-200V□ *1
Number of channels		2	
Applicable light		FLV-LN series	
Power supply voltage *2		100 to 120 VAC, 50/60 Hz	200 to 240 VAC, 50/60 Hz
Current consumption		7 A max.	4 A max.
Power of connected light		2ch total 240 W max. 120 W max. for 1ch	
Drive method		Constant voltage method	
Lighting method		Trigger lighting, Continuous lighting	
Intensity control method		Current light adjustment : 5 A max.	
Luminance control method		Turning the light off in synchronization with input from the trigger input terminal	
Trigger lighting delay time		T_on: 500 μs max.	
External interface		Trigger input terminal block	
Dielectric strength		1500 VAC 50/60 Hz 1 min	
Insulation resistance		20 MΩ (500 VDC)	
Ambient temperature		Operating: 0 to 40°C, Storage: -15 to 60°C (with no icing or condensation)	
Ambient humidity		Operating/storage: 35% to 85% (with no condensation)	
Degree of protection		IP20 (IEC60529)	
Vibration resistance (destructive)		10 to 150 Hz, (0.2 mm double amplitude) 80 min each in X, Y, and Z directions	
Shock resistance (destructive)		150 m/s ² 3 times each in 6 directions (up/down, left/right, forward/backward)	
Materials		Case: Aluminum	
Weight		Approx. 2.1 kg	
Accessories		Instruction sheet, AC input cable *1	
Applicable standards		EN61326-1 *3	

*1. The suffixed symbol of the model name means the plug type of the accessory cable. A model name with no suffix means type A.

*2. This product is the exclusive use for apparatus inclusion in the industrial machine field.

This product cannot be used for the connection to electric power equipment, such as a common residence, store, and small establishment, because of nonconformity with to Electrical Appliance and Material Safety Law (PSE).

*3. Electromagnetic environment: Industrial electromagnetic environment (EN/IEC 61326-1 Table 2)

Also, the following condition is applied to the immunity test of this product.

There are case that Lighting brightness fluctuate Max 10%.

Analog Lighting Controller for FLV Series FLV-ATC Series

Connecting to External Trigger Input Terminal Block

- Connection of this terminal block is not required if lighting illumination trigger input from outside is not used.

<Connection of trigger input terminal block>

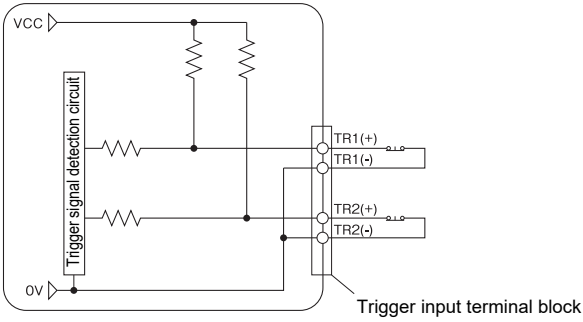

* Current flowing through the short circuit is less than 2 mA.

FLV-ATC26024-□

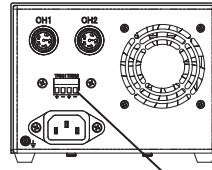

Trigger input terminal block CH1 to CH2

Short-circuiting (+) and (-) of TR1 to TR2 respectively makes the trigger input status OFF, turning the light OFF.
Releasing (+) and (-) makes the status ON, turning the light ON.

[Important]

- Make sure that excessive force is not imposed on the wire and terminal block.
- Do not install the product in which loads are constantly applied to the terminal block such as the wire being under tension.
- When wiring the terminal block, use an applicable cable (AWG 14 to 24, tip processing length: 7 mm).

Dimensions

(Unit: mm)

● FLV-ATC26024-□

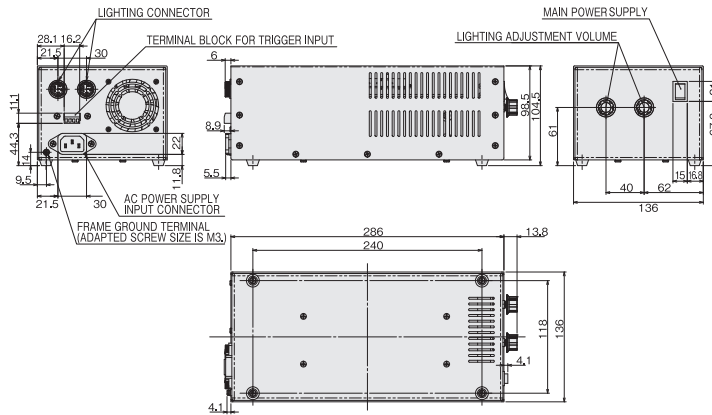

Digital Lighting Controller for FLV Series

3Z4S-LT IDGB Series

Standard Models
FLV Series

High-brightness Models
FL Series

LED Characteristics

Lenses

PWM light control power unit for LED lights



Note: Orders for 3Z4S-LT IDGB series will be accepted until the end of December 2023.

Product Features

- Fully synchronized external ON/OFF signals and lighting outputs.
- 3 types of operation using external ON/OFF signals: Normal, Repeat, and Single.
- Delay time from inputting an external ON signal to turning ON the light can be set.
- Brightness can be adjusted between 256 levels within a duty cycle range of 0 to 100% at a frequency of 125 kHz.
- Clear digital display for easy to read set values
- DIN track mounting

Ordering Information

Digital Lighting Controllers

Model	Number of channels	Applicable light *1			Input voltage	Output voltage	Capacity (W)
		Standard Light FLV Series *2	Spot Light FLV-EP Series *2	Line Light FLV-LN Series *2			
3Z4S-LT IDGB-50M2-L01-L	2	○	×	×	24 VDC	24 VDC	46
3Z4S-LT IDGB-150M4-L01-L	4	○	×	×			144

*1. ○:Connectable ×:Not connectable

*2. Standard light means all FLV-series Lights excluding the FLV-EP-series Spot Lights and the FLV-LN-series Line Lights.

External ON/OFF Cables

Model	Cable length	Weight
3Z4S-LT IC-MIL-20-1	1 m	Approx. 100 g
3Z4S-LT IC-MIL-20-2	2 m	Approx. 190 g
3Z4S-LT IC-MIL-20-3	3 m	Approx. 280 g
3Z4S-LT IC-MIL-20-5	5 m	Approx. 450 g
3Z4S-LT IC-MIL-20-10	10 m	Approx. 900 g

External Light Control Cables

Model	Cable length	Weight
3Z4S-LT IC-MIL-26-1	1 m	Approx. 110 g
3Z4S-LT IC-MIL-26-2	2 m	Approx. 220 g
3Z4S-LT IC-MIL-26-3	3 m	Approx. 330 g
3Z4S-LT IC-MIL-26-5	5 m	Approx. 540 g
3Z4S-LT IC-MIL-26-10	10 m	Approx. 1,070 g

Digital Lighting Controller for FLV Series 3Z4S-LT IDGB Series

Specifications

Item	Model	3Z4S-LT IDGB-50M2-L01-L	3Z4S-LT IDGB-150M4-L01-L
Rated capacity		46 W	144 W
Number of channels		2	4
Applicable light		FLV Series (excluding FLV-EP Series and FLV-LN Series)	
Power supply voltage		24 VDC±5%	
Current consumption		2.08 A max.	6.25 A max.
Power of connected light *1		2 ch total 46 W max. 46 W max. for 1 ch	4 ch total 144 W max. 70 W max. for 1 ch
		<div style="border: 1px solid black; padding: 10px;"> <p style="text-align: center;">⚠ CAUTION</p> <p style="text-align: center;">The output voltage of this product is 24 V. Do not connect any light with rated voltage of 12 V.</p>  </div>	
Drive method		Constant voltage method	
Lighting method		Continuous lighting	
Luminance control method		PWM light adjustment	
Light adjustment		256 levels (Duty ratio of 0 to 100% at a lighting frequency of 125 kHz) *3	
Delay time		0 to 9,000 μs in 1 μs increments (Actual output will be delayed by the sum of the external ON/OFF response time described below and the set delay time.)	
External ON/OFF response *2		High mode --- OFF → ON: 40 μs or less, ON → OFF: 10 μs or less Low mode --- OFF → ON: 10 μs or less, ON → OFF: 40 μs or less	
Ambient temperature		Operating: 0 to 50 °C, Storage: -20 to 65 °C, (with no icing or condensation)	
Ambient humidity		Operating and storage: 35% to 85% (with no condensation)	
Cooling method		Natural air cooling	Forced air cooling
Weight		Approx. 700 g	Approx. 1,000 g
Overvoltage category		Category I	
Applicable standards		EMC Directives: EN 55011 Group 1 Class A, EN 61000-6-2	
Environmental regulation		Conforms to RoHS Directive	
Pollution degree		2	

*1. When connecting lights to multiple channels, make sure that the total power consumption of the connected lights is within the specification of the lighting controller.

*2. Measured with a rated light connected.

*3. There will be some variation in light adjustment between units when the level is set between 0 and 15 or between 250 and 255.

Dimensions

(Unit: mm)

Digital Lighting Controllers IDGB-50M2-L01-L

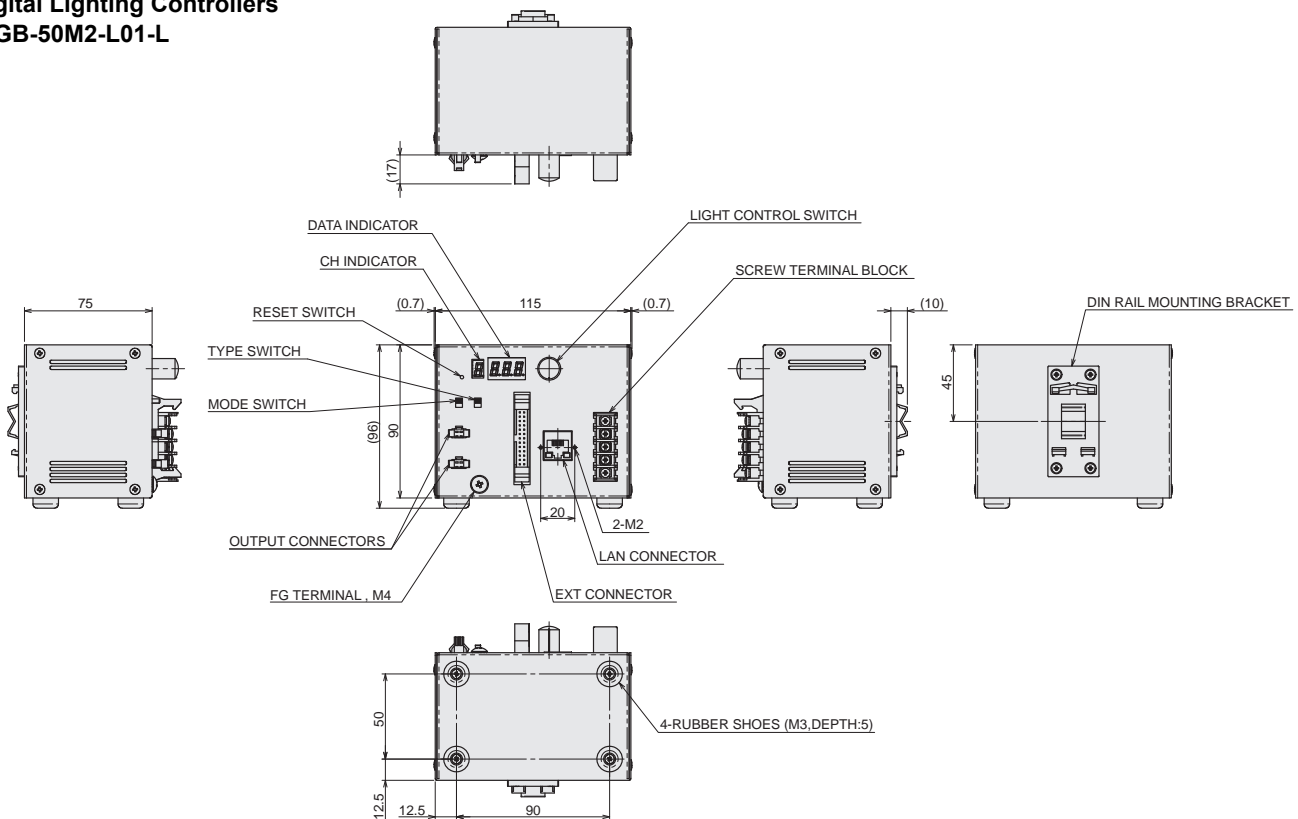

Digital Lighting Controller for FLV Series 3Z4S-LT IDGB Series

IDGB-150M4-L01-L

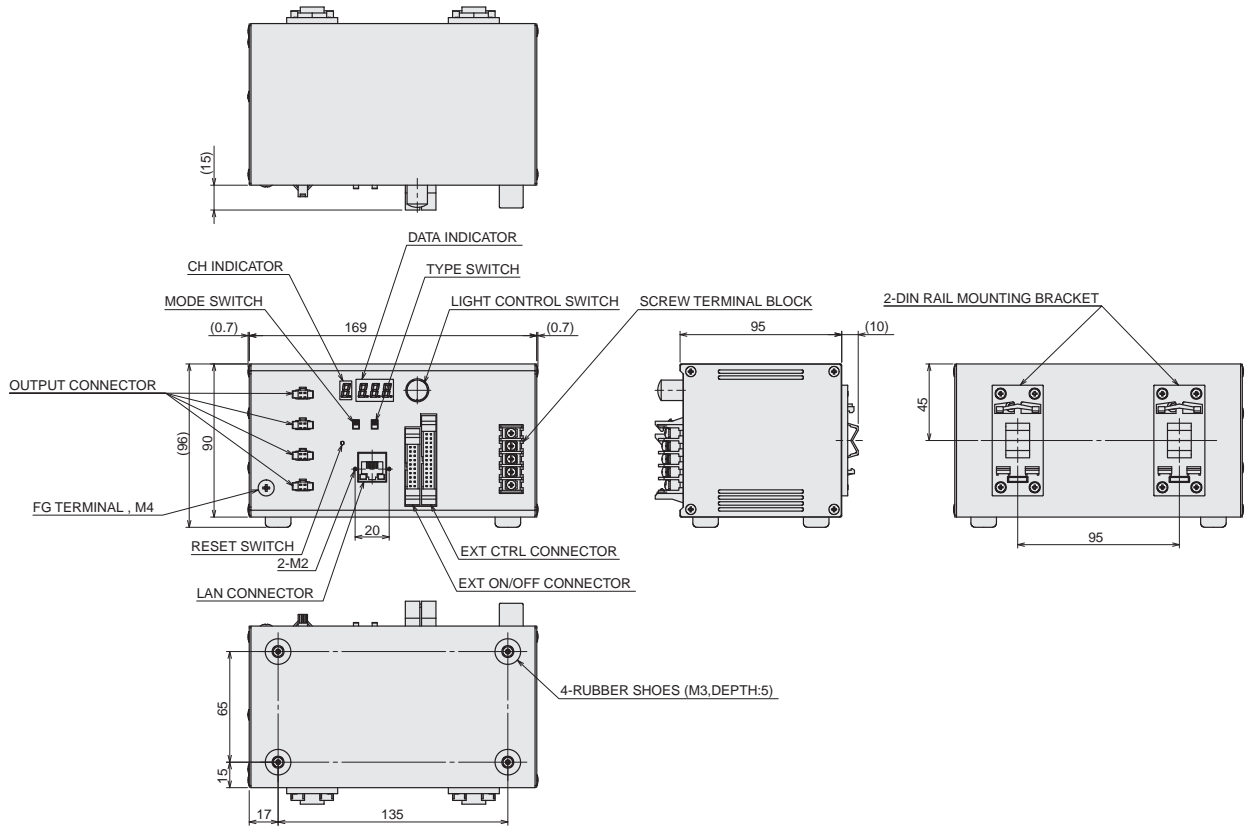

External ON/OFF Cables IC-MIL-20-□

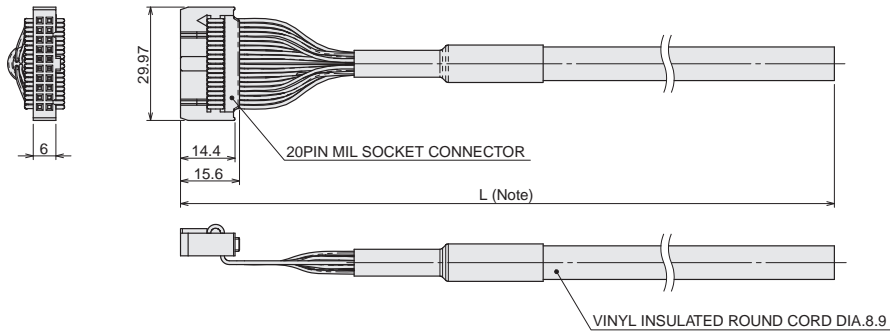

Note: Cable length L is as follows by the type.

Type	Cable length L
3Z4S-LT IC-MIL-20-1	1,000
3Z4S-LT IC-MIL-20-2	2,000
3Z4S-LT IC-MIL-20-3	3,000
3Z4S-LT IC-MIL-20-5	5,000
3Z4S-LT IC-MIL-20-10	10,000

External Light Control Cables IC-MIL-26-□

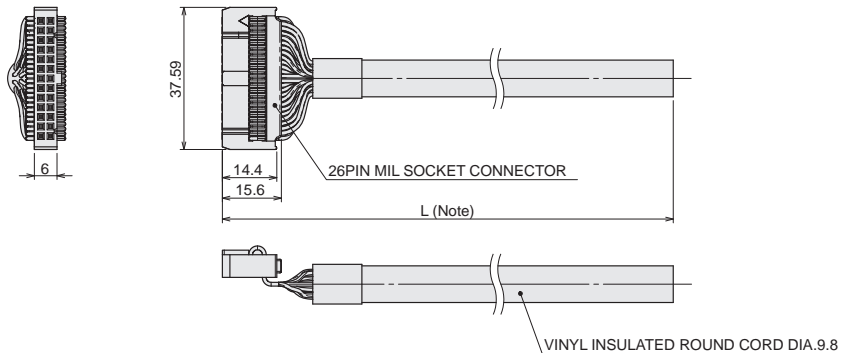

Note: Cable length L is as follows by the type.

Type	Cable length L
3Z4S-LT IC-MIL-26-1	1,000
3Z4S-LT IC-MIL-26-2	2,000
3Z4S-LT IC-MIL-26-3	3,000
3Z4S-LT IC-MIL-26-5	5,000
3Z4S-LT IC-MIL-26-10	10,000

Cable/Diffusion Plate

Cable

Ordering Information

Series	Type	Model	Cable Length	Weight	Dimensions	
Extension Cable for Standard Light *1	Standard Cable	FLV-XC1	1 m	Approx. 30g	A	
		FLV-XC2	2 m	Approx. 50g		
		FLV-XC3	3 m	Approx. 70g		
		FLV-XC5	5 m	Approx. 110g		
		FLV-XC10	10 m	Approx. 210g		
	Bend resistant Cable	FLV-XC1R	1 m	Approx. 40g	B	
		FLV-XC2R	2 m	Approx. 60g		
		FLV-XC3R	3 m	Approx. 80g		
		FLV-XC5R	5 m	Approx. 130g		
		FLV-XC10R	10 m	Approx. 250g		
Extension Cable for Spot Light	Standard Cable	FLV-XC1EP	1 m	Approx. 30g	C	
		FLV-XC2EP	2 m	Approx. 50g		
		FLV-XC3EP	3 m	Approx. 70g		
		FLV-XC5EP	5 m	Approx. 110g		
	Bend resistant Cable	FLV-XC1EPR	1 m	Approx. 40g	D	
		FLV-XC2EPR	2 m	Approx. 60g		
		FLV-XC3EPR	3 m	Approx. 80g		
		FLV-XC5EPR	5 m	Approx. 130g		
	Extension Cable for Line Light	Standard Cable	FLV-XC1LN	1 m	Approx. 200g	E
			FLV-XC2LN	2 m	Approx. 270g	
FLV-XC3LN			3 m	Approx. 320g		
FLV-XC5LN			5 m	Approx. 440g		
Branch Cable for Standard Light *1	Standard Cable	FLV-XC1S2	1 m	Approx. 30g	F	
		FLV-XC2S2	2 m	Approx. 50g		
		FLV-XC3S2	3 m	Approx. 80g		
		FLV-XC5S2	5 m	Approx. 120g		

*1. Standard light means all FLV-series Lights excluding the FLV-EP-series Spot Lights and the FLV-LN-series Line Lights.

Dimensions

(Unit: mm)

Model	L
FLV-XC1	1,000
FLV-XC2	2,000
FLV-XC3	3,000
FLV-XC5	5,000
FLV-XC10	10,000

Model	L
FLV-XC1R	1,000
FLV-XC2R	2,000
FLV-XC3R	3,000
FLV-XC5R	5,000
FLV-XC10R	10,000

A FLV-XC□

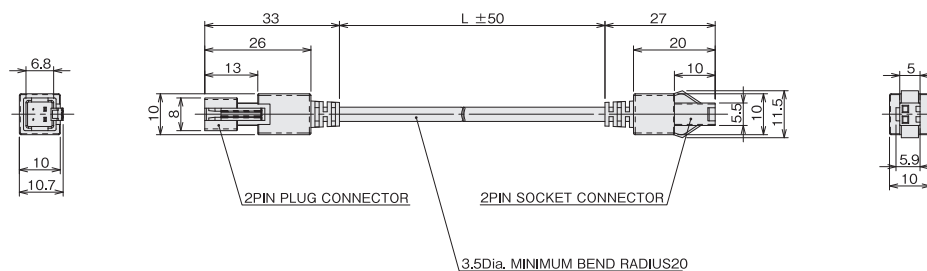

B FLV-XC□R

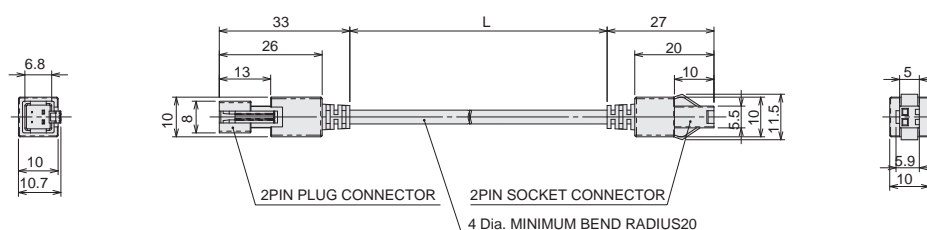

Options for FLV Series Cable/Diffusion Plate

Standard Models
FLV Series

High-brightness Models
FL Series

LED Characteristics

Lenses

Diffusion Plate/Polarization Plate

Ordering Information

Diffusion Plate

Type	Model			Applicable light
	High	Middle	Low	
Transparency rate	Low	Middle	High	
Diffusivity	Low	Middle	High	
For FLV-DR-series Direct ring light	FLV-DR3220DF	FLV-DR3220DF50	FLV-DR3220DF30	FLV-DR3220□
	FLV-DR4415DF	FLV-DR4415DF50	FLV-DR4415DF30	FLV-DR4415□
	FLV-DR5030DF	FLV-DR5030DF50	FLV-DR5030DF30	FLV-DR5030□
	FLV-DR6030DF	---	---	FLV-DR6030UV
	FLV-DR6615DF	FLV-DR6615DF50	FLV-DR6615DF30	FLV-DR6615□
	FLV-DR7000DF	FLV-DR7000DF50	FLV-DR7000DF30	FLV-DR7000□
	FLV-DR7030DF	FLV-DR7030DF50	FLV-DR7030DF30	FLV-DR7030□
	FLV-DR7530DF	---	---	FLV-DR7530UV
	FLV-DR9000DF	FLV-DR9000DF50	FLV-DR9000DF30	FLV-DR9000□
	FLV-DR9030DF	FLV-DR9030DF50	FLV-DR9030DF30	FLV-DR9030□
For FLV-DL-series Low angle ring light	FLV-DR9215DF	FLV-DR9215DF50	FLV-DR9215DF30	FLV-DR9215□
	FLV-DR12030DF	FLV-DR12030DF50	FLV-DR12030DF30	FLV-DR12030□
	FLV-DL5890DF	FLV-DL5890DF50	FLV-DL5890DF30	FLV-DL5890□
	FLV-DL7260DF	FLV-DL7260DF50	FLV-DL7260DF30	FLV-DL7260□
For FLV-BR-series Bar light	FLV-DL12060DF	FLV-DL12060DF50	FLV-DL12060DF30	FLV-DL12060□
	FLV-DL15060DF	FLV-DL15060DF50	FLV-DL15060DF30	FLV-DL15060□
	FLV-BR6022DF	FLV-BR6022DF50	FLV-BR6022DF30	FLV-BR6022□
	FLV-BR6424DF	---	---	FLV-BR6424UV
	FLV-BR8532DF	FLV-BR8532DF50	FLV-BR8532DF30	FLV-BR8532□
	FLV-BR11222DF	FLV-BR11222DF50	FLV-BR11222DF30	FLV-BR11222□
	FLV-BR11624DF	---	---	FLV-BR11624UV
	FLV-BR14030DF	FLV-BR14030DF50	FLV-BR14030DF30	FLV-BR14030□
	FLV-BR15020DF	FLV-BR15020DF50	FLV-BR15020DF30	FLV-BR15020□
	FLV-BR21222DF	FLV-BR21222DF50	FLV-BR21222DF30	FLV-BR21222□
FLV-BR21230DF	FLV-BR21230DF50	FLV-BR21230DF30	FLV-BR21230□	
FLV-BR38037DF	FLV-BR38037DF50	FLV-BR38037DF30	FLV-BR38037□	
FLV-BR48031DF	FLV-BR48031DF50	FLV-BR48031DF30	FLV-BR48031□	

Polarization Plate

Type	Model	Applicable light
For FLV-DR-series Direct ring light	FLV-DR3220PL	FLV-DR3220□
	FLV-DR4415PL	FLV-DR4415□
	FLV-DR5030PL	FLV-DR5030□
	FLV-DR6615PL	FLV-DR6615□
	FLV-DR7000PL	FLV-DR7000□
	FLV-DR7030PL	FLV-DR7030□
	FLV-DR9000PL	FLV-DR9000□
	FLV-DR9030PL	FLV-DR9030□
	FLV-DR9215PL	FLV-DR9215□
	FLV-DR12030PL	FLV-DR12030□
For FLV-DL-series Low angle ring light	FLV-DL7260PL	FLV-DL7260□
	FLV-DL12060PL	FLV-DL12060□
	FLV-DL15060PL	FLV-DL15060□
For FLV-BR-series Bar light	FLV-BR6022PL	FLV-BR6022□
	FLV-BR8532PL	FLV-BR8532□
	FLV-BR11222PL	FLV-BR11222□
	FLV-BR14030PL	FLV-BR14030□
	FLV-BR15020PL	FLV-BR15020□
	FLV-BR21222PL	FLV-BR21222□
	FLV-BR21230PL	FLV-BR21230□
	FLV-BR38037PL	FLV-BR38037□
	FLV-BR48031PL	FLV-BR48031□
	FLV-BR6022PL-V	FLV-BR6022□
	FLV-BR8532PL-V	FLV-BR8532□
	FLV-BR11222PL-V	FLV-BR1122□
	FLV-BR14030PL-V	FLV-BR14030□
	FLV-BR15020PL-V	FLV-BR15020□
	FLV-BR21222PL-V	FLV-BR21222□
FLV-BR21230PL-V	FLV-BR21230□	
FLV-BR38037PL-V	FLV-BR38037□	
FLV-BR48031PL-V	FLV-BR48031□	

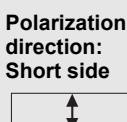
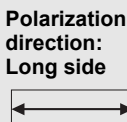

MDMC Light FL-MD Series

Standard Models
FLV Series

High-brightness Models
FL Series

RGB full color light flexibly changes illumination directions, colors, and light intensities.



Product Features

- Combination of illumination directions, colors, and light intensities.
- Flexible illumination patterns for additional objects or inspection items.

Illumination Structure

Choose the best pattern by combining illumination directions x full color RGB x 128 brightness levels of 13 blocks

Full color coaxial light

Full color 3-tier x 4-block dome light

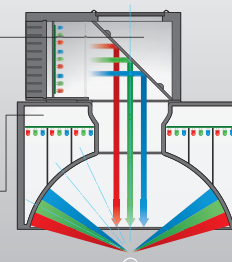

LED Characteristics

Applications

Standard Lighting System

Different lights are required for different defects

Glass surface inspection

Coaxial light

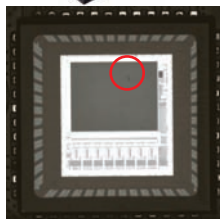

Wire inspection

Low angle light

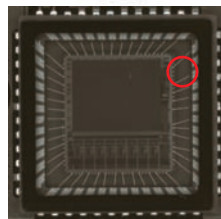

FL-MD Series

One light clearly shows both broken wires and dirt on elements

Inspection for broken wires and dirt on elements

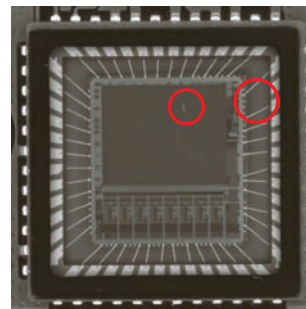

Lenses

MDMC Light FL-MD Series

Ordering Information

Model	Color	Dimensions			Weight (g)
		Outside dimensions (mm)	Height (mm)	Drawing	
FL-MD90MC	RGB full color	125 × 90	82	A	800
FL-MD180MC	RGB full color	215 × 180	154	B	3000

Note: Refer to page 69 for LED Characteristics.

Specifications

Item	Model	FL-MD90MC	FL-MD180MC
Applicable controller		FH series	
Applicable camera		FH-S series, FZ-S series	
Lighting color (peak wavelength)		R: Red (Typ.635nm), G: Green (Typ.525nm), B: Blue (Typ.465nm)	
Light source		LED	
LED safety		W,B: Risk Group 2, R,G: Risk Group 1	W,G,B: Risk Group 2, R: Risk Group 1
Power supply voltage		24 VDC±10% (including ripple)	
Recommended power supply		S8VK-G12024 (manufactured by OMRON, 24 VDC, 5 A, 120 W)	
Current consumption		1.5 A max.	3.0 A max.
Drive method		Constant voltage method	
Lighting method		Trigger lighting	
Luminance control method		Duty light adjustment: PWM frequency of 200 kHz, light adjustment of 128 levels (configured with vision system controller)	
Trigger lighting		Lighting in synchronization with trigger input timing from the controller (configured with vision system controller).	
Lighting duration setting		Auto setting in accordance with shutter speed.	
Lighting time control		Set with vision system controller or set in accordance with shutter speed.	
External interface		Camera connection cable (directly connected with the main unit) Cable length: 500 mm	
Ambient temperature		Operating: 0 to 40°C, Storage: -15 to 60°C (with no icing or condensation)	
Ambient humidity		Operating and storage: 35% to 85% (with no condensation)	
Degree of protection		IP20 (IEC60529)	
Vibration resistance		10 to 150 Hz, (0.35mm half-amplitude) 80 min each in X, Y, and Z directions	
Shock resistance		150 m/s ² 3 times each in 6 directions (up/down, left/right, forward/backward)	
Material		Case: Aluminum, PC, PMMA Cable: PVC	
Weight		Approx. 0.8 kg	Approx. 3.0 kg
Accessories		Instruction Sheet, Compliance Sheet, 24 V power supply terminal block (male)	

- Note: 1. Turn ON the power of this product and vision system controller at the same time or this product first.
 2. This light complies with the EN standard (EN61326-1) (Electromagnetic environment: Industrial electromagnetic environment (EN/IEC 61326-1 Table 2)) Also, the following condition is applied to the immunity test of this product.
 There may be cases that light brightness fluctuates within 10%.
 3. This light complies with the KC standard.

Dimensions

(Unit:mm)

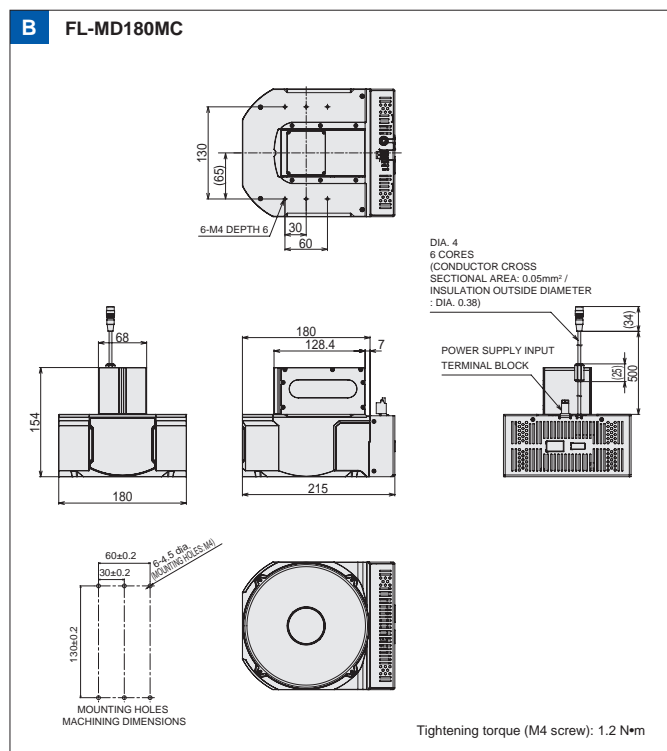
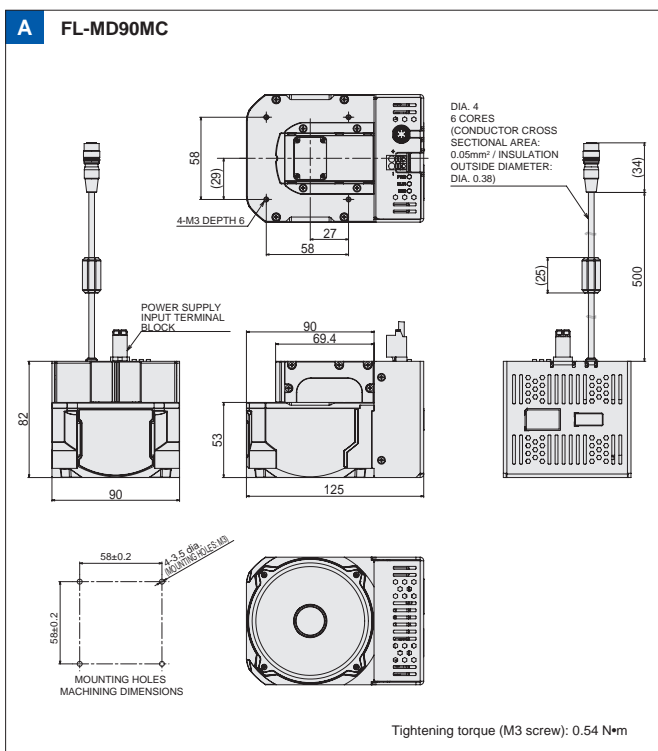

Photometric Stereo Light FL-PS Series

Standard Models
FLV Series

High-brightness Models
FL Series

Shows defects accurately.



Product Features

- Captures images under different illumination directions to extract “characters” and “scratches and dents”.

Illumination Structure

Four lights are lit in turn, and variations in brightness are analyzed. Printed characters with little variation in brightness even under different illumination directions are extracted as texture, and a dent with huge variation in brightness is extracted as a shape.

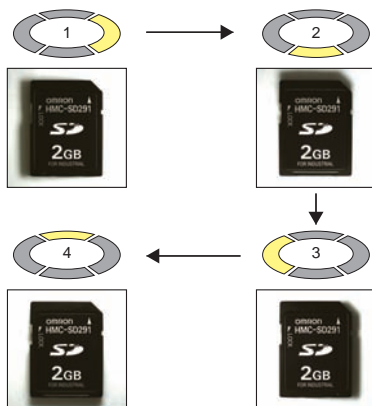

Applications

Inspection of dents on characters

Standard light



Extracts scratches only



(Shape)

Extracts characters only



(Texture)

LED Characteristics

Lenses

Photometric Stereo Light FL-PS Series

Ordering Information

Model	Color	Dimensions				Lighting controller			Weight (g)
		External ring diameter (mm)	Internal ring diameter (mm)	Height (mm)	Drawing	FL-STC□	FL-TCC□	FL-TCC1PS	
FL-PS90W	White	90 dia.	50 dia.	35	A	×	×	○	200
FL-PS140W	White	140 dia.	100 dia.	35	B	×	×	○	350
FL-PS260W	White	260 dia.	200 dia.	35	C	×	×	○	800

Note: Refer to page 69 for LED Characteristics.

○: Connectable ×: Not connectable

Specifications

Item	Model	FL-PS90W	FL-PS140W	FL-PS260W
Applicable controller		FL-TCC1PS		
Lighting color		W: White		
Light source		LED		
LED safety		Risk group 2		
Power consumption		32W	47W	61W
Ambient temperature		Operating: 0 to 40°C Storage: -15 to 60°C (with no icing nor no condensation)		
Ambient humidity		Operating and storage: 35% to 85% (no condensation)		
Degree of protection		IP20(IEC60529)		
Vibration resistance (destructive)		10 to 150 Hz, (0.35mm half-amplitude) 80 min. each in X, Y, and Z directions		
Shock resistance (destructive)		150 m/s ² 3 times each in 6 directions (up/down, left/right, forward/backward)		
Materials		Case: Aluminum, PMMA		
Weight		Approx. 200g	Approx. 350g	Approx. 800g
Accessories		INSTRUCTION SHEET (THIS SHEET), Compliance Sheet		

Dimensions

(Unit:mm)

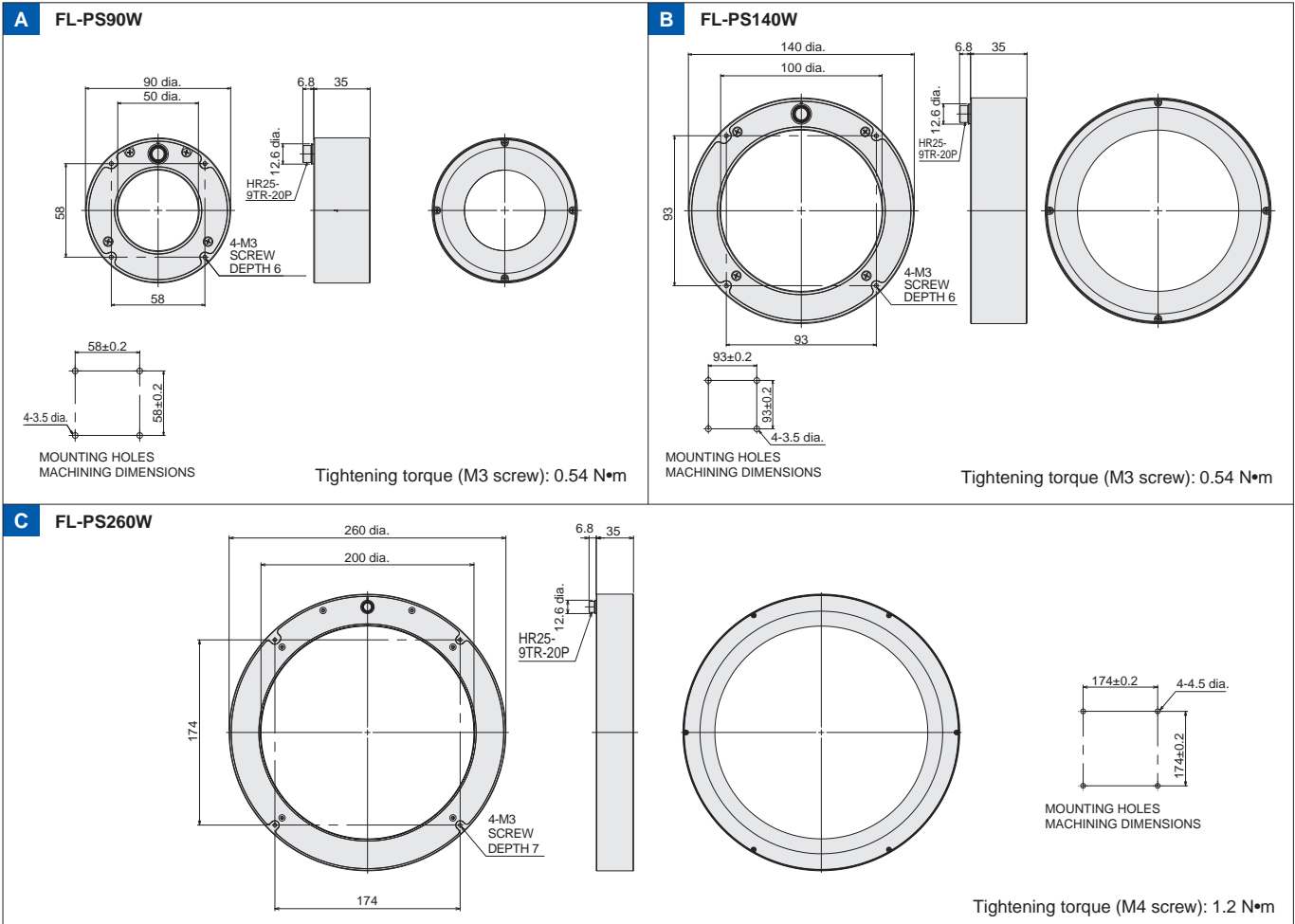

Bar Light FL-BR Series

The highest level* of brightness in the industry.
This series is structured for adaptable wiring and mounting.



* Based on OMRON testing in November 2010.

Product Features

- High-brightness ODR lighting beyond the limitations of LEDs.
- Stable inspection even for high-speed applications.
- Bright even through a polarizing filter.
- Easy wiring, mounting, and adjustment.

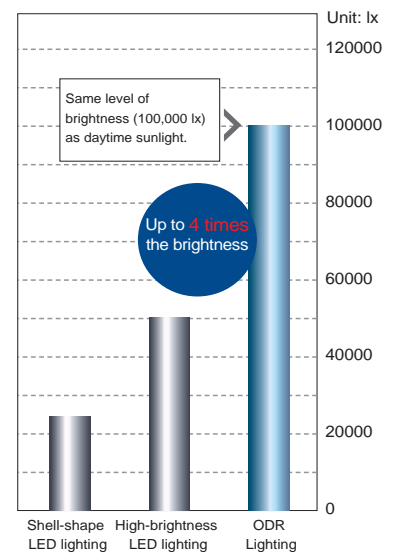

Wiring



The cable can extend from either direction, allowing for horizontal or vertical wiring layouts on the mounting surface.

Mounting and Adjustment



The light is structured for mounting with nuts to an arm on the back or side surfaces. Minute changes in the position can be achieved by sliding the light.



Specialized mounting brackets enable mounting at a flexible angle.

Bar Light FL-BR Series

Illumination Structure

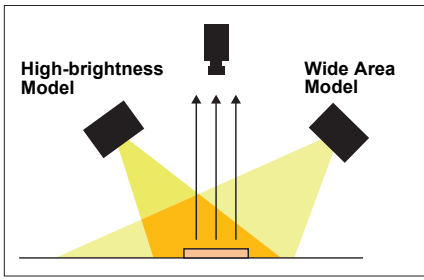

Lighting Intensity Distribution Characteristics

High-brightness Model (FL-BR9120W-H)

X axis (long axis)

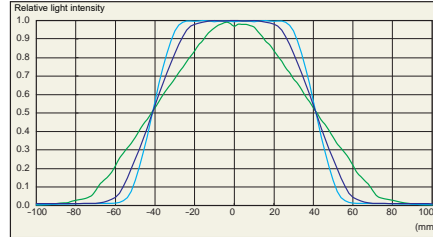

Y axis (short axis)

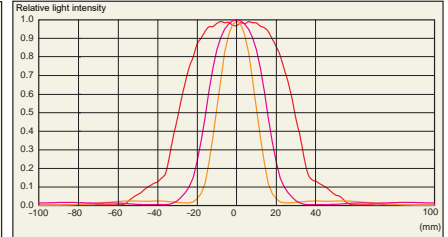

Wide Area Model (FL-BR9120W)

X axis (long axis)

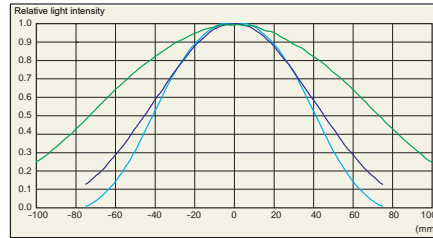

Y axis (short axis)

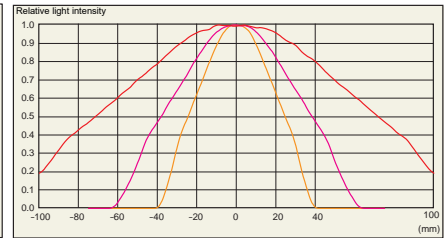

Applications

Standard light



It is difficult to read characters with low contrast.

FL Series



Sharp images are created of both two-dimensional codes and characters.

Standard light



Inspection is not possible because of workpiece blurring or a lack of brightness.

FL Series

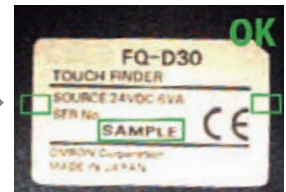

Complete extraction of edges and characters.

Ordering Information

Model	Color	Type	Dimensions				Controller			Weight (g)	Options	
			Lighting Area Dimension (mm)	Outside Dimension (mm)	Height (mm)	Drawing	FL-STC <input type="checkbox"/>	FL-TCC <input type="checkbox"/>	FL-TCC1PS <input type="checkbox"/>		Diffusion Plate	Polarization Plate
FL-BR5020W	WHITE	Wide Area Model	40.8x9	49.8x20	20	A	<input type="radio"/>	<input type="radio"/>	<input type="checkbox"/>	40	<input type="radio"/>	<input type="checkbox"/>
FL-BR5020W-H	WHITE	High-brightness Model					<input type="radio"/>	<input type="radio"/>	<input type="checkbox"/>		<input type="radio"/>	<input type="checkbox"/>
FL-BR9120W	WHITE	Wide Area Model	81.6x9	90.6x20	20	B	<input type="radio"/>	<input type="radio"/>	<input type="checkbox"/>	70	<input type="radio"/>	<input type="checkbox"/>
FL-BR9120W-H	WHITE	High-brightness Model					<input type="radio"/>	<input type="radio"/>	<input type="checkbox"/>		<input type="radio"/>	<input type="checkbox"/>
FL-BR13120W	WHITE	Wide Area Model	122.4x9	131.4x20	20	C	<input type="radio"/>	<input type="radio"/>	<input type="checkbox"/>	100	<input type="radio"/>	<input type="checkbox"/>
FL-BR13120W-H	WHITE	High-brightness Model					<input type="radio"/>	<input type="radio"/>	<input type="checkbox"/>		<input type="radio"/>	<input type="checkbox"/>

Note: Refer to page 69 for LED Characteristics.

The color of white LEDs can vary due to intrinsic characteristics. Confirm suitability for the application in advance.

: Applicable : Not applicable

Specifications

Model	Wide Area Model	High-brightness Model	Wide Area Model	High-brightness Model	Wide Area Model	High-brightness Model
	FL-BR5020W	FL-BR5020W-H	FL-BR9120W	FL-BR9120W-H	FL-BR13120W	FL-BR13120W-H
Light source	White LEDs					
Vibration resistance	10 to 150 Hz (Double amplitude: 0.7 mm), 80 min each in X, Y, and Z directions					
Shock resistance	150 m/s ² 3 times each in 6 directions					
Ambient temperature	Operating: 0 to 40°C, Storage: -15 to 60°C (with no icing or condensation)					
Ambient humidity	Operating/storage: 35% to 85% (with no condensation)					
Ambient atmosphere	No corrosive gases.					
Degree of protection	IEC60259 IP20					
Weight	Approx. 40 g		Approx. 70 g		Approx. 100 g	
Materials	Case: Aluminum; Cover, side parts, and lens: PC; Cable: Heat resistant polyvinyl chloride; Connector: Thermoplastic resin with glass					
LED safety	Risk Group 2 (IEC 62471)					
Accessories	Instruction sheet					

The color of white LEDs can vary due to intrinsic characteristics. Confirm suitability for the application in advance.

Dimensions

(Unit:mm)

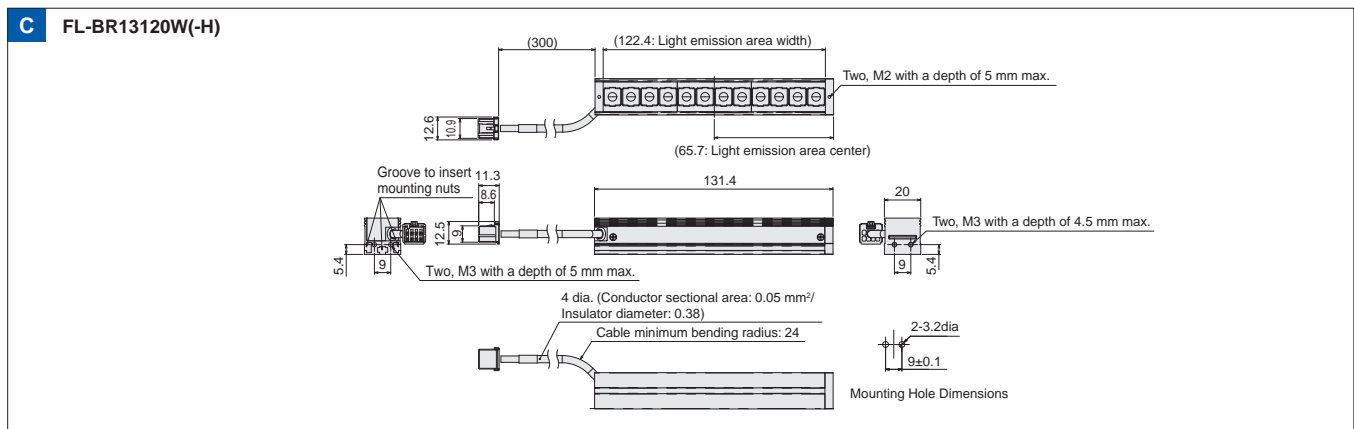
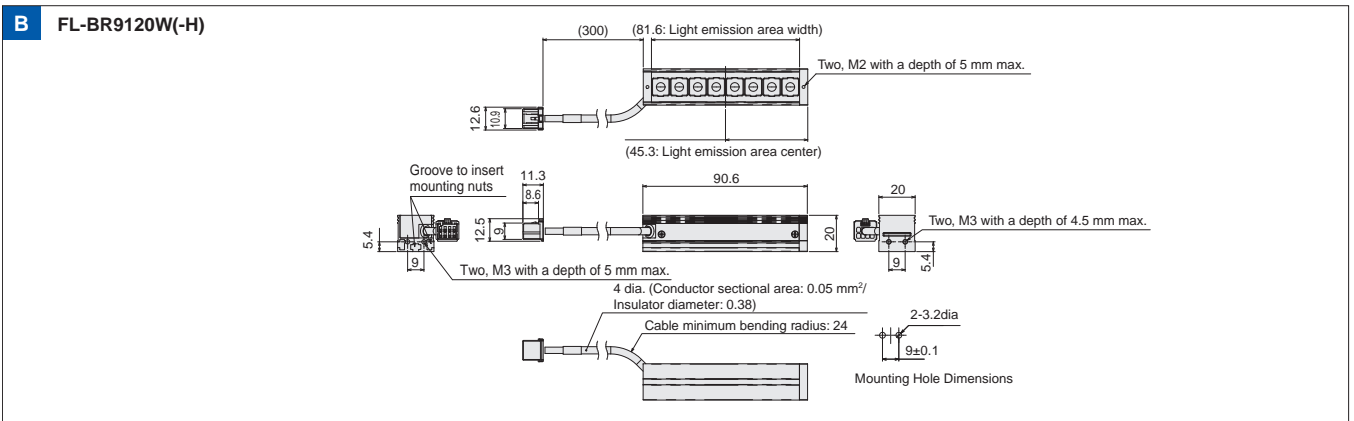
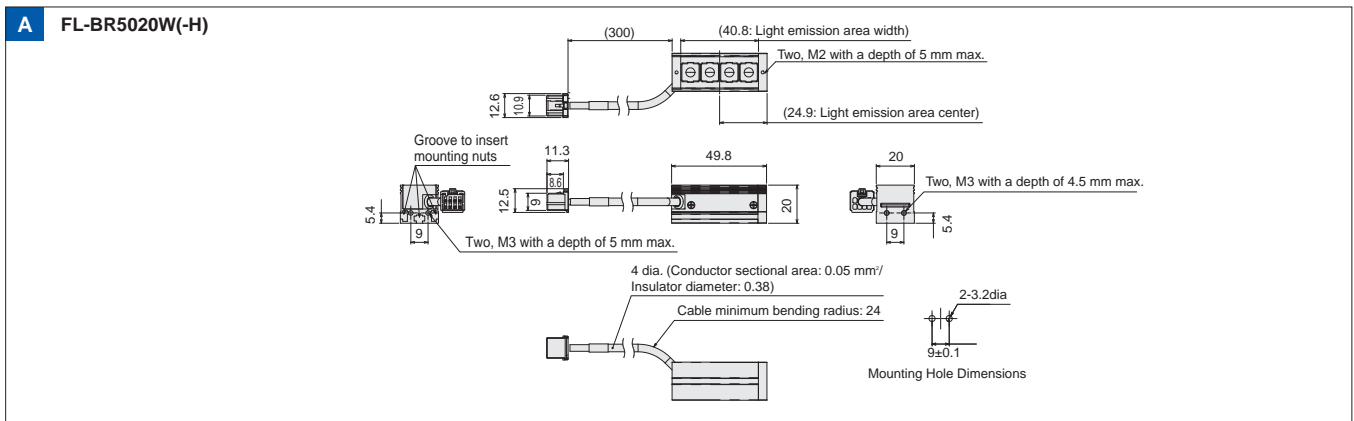

Direct Ring Light FL-DR Series

Clear Images with Industry's Best Level* of Brightness and Illumination over a Wide Field of View



* Based on OMRON testing in November 2010.

Product Features

- High brightness in a small package.
- Wide range of working distance.

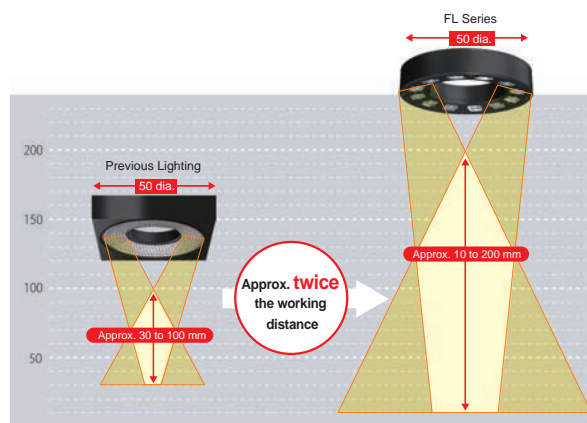
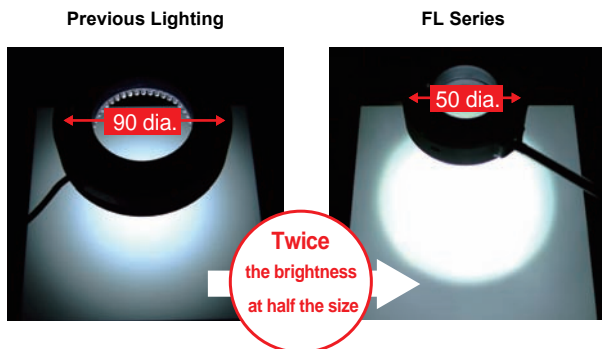

Illumination Structure

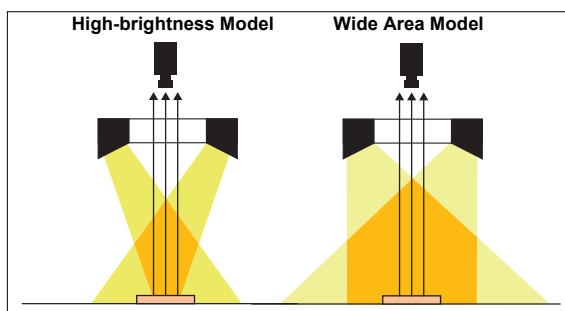

Lighting Intensity Distribution Characteristics

High-brightness Model (FL-DR50W-H)

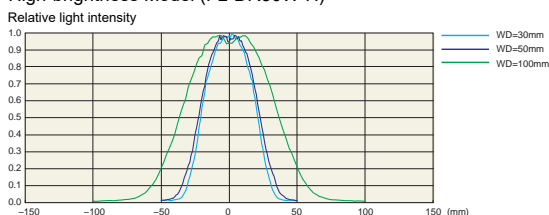

Wide Area Model (FL-DR50W)

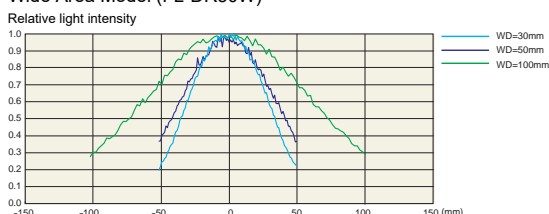

Standard Models
FLV Series

High-brightness Models
FL Series

LED Characteristics

Lenses

Applications

Previous Lighting

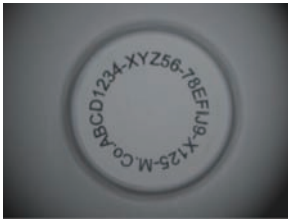

Faster lines make it necessary to increase shutter speeds, but then the clarity of workpiece images decreases.

FL-series



More than sufficient brightness is provided for high-speed lines.

Previous Lighting



It was necessary to create different inspection standards for each section.

FL-series



With uniform lighting from corner to corner, it is possible to inspect.

Ordering Information

Model	Color	Type	Dimensions				Controller			Weight (g)	Options	
			External Ring Diameter (mm)	Internal Ring Diameter (mm)	Lighting Angle (Deg)	Drawing	FL-STC□	FL-TCC□	FL-TCC1PS		Diffusion Plate	Polarization Plate
FL-DR32W	WHITE	Wide Area Model	32 dia.	10 dia.	20 deg.	A	○	○	×	25	○	○
FL-DR32W-H	WHITE	High-brightness Model										
FL-DR50W	WHITE	Wide Area Model	50 dia.	28 dia.	10 deg.	B	○	○	×	30	○	○
FL-DR50W-H	WHITE	High-brightness Model										
FL-DR90W	WHITE	Wide Area Model	90 dia.	50 dia.	20 deg.	C	○	○	×	70	○	○
FL-DR90W-H	WHITE	High-brightness Model										

Note: Refer to page 69 for LED Characteristics.

The color of white LEDs can vary due to intrinsic characteristics. Confirm suitability for the application in advance.

○: Applicable ×: Not applicable

Specifications

Model	Wide Area Model	High-brightness Model	Wide Area Model	High-brightness Model	Wide Area Model	High-brightness Model
	FL-DR32W	FL-DR32W-H	FL-DR50W	FL-DR50W-H	FL-DR90W	FL-DR90W-H
Light source	White LEDs					
Vibration resistance	10 to 150 Hz (Double amplitude: 0.7 mm), 80 min each in X, Y, and Z directions					
Shock resistance	150 m/s ² 3 times each in 6 directions					
Ambient temperature	Operating: 0 to 40°C, Storage: -15 to 60°C (with no icing or condensation)					
Ambient humidity	Operating/storage: 35% to 85% (with no condensation)					
Ambient atmosphere	No corrosive gases.					
Degree of protection	IEC60259 IP20					
Weight	Approx. 25 g		Approx. 30 g		Approx. 70 g	Approx. 80 g
Materials	Case and Lens: PC, Cable: Heat resistant polyvinyl chloride, Connector: Thermoplastic resin with glass					
LED safety	Risk Group 2 (IEC 62471)					
Accessories	Instruction sheet					

The color of white LEDs can vary due to intrinsic characteristics. Confirm suitability for the application in advance.

Direct Ring Light FL-DR Series

Dimensions

(Unit:mm)

Standard Models
FLV Series

High-brightness Models
FL Series

LED Characteristics

Lenses

A FL-DR32W(-H)

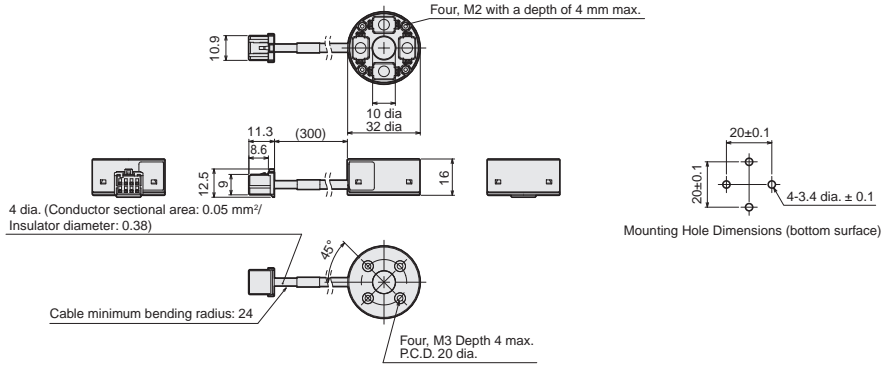

B FL-DR50W(-H)

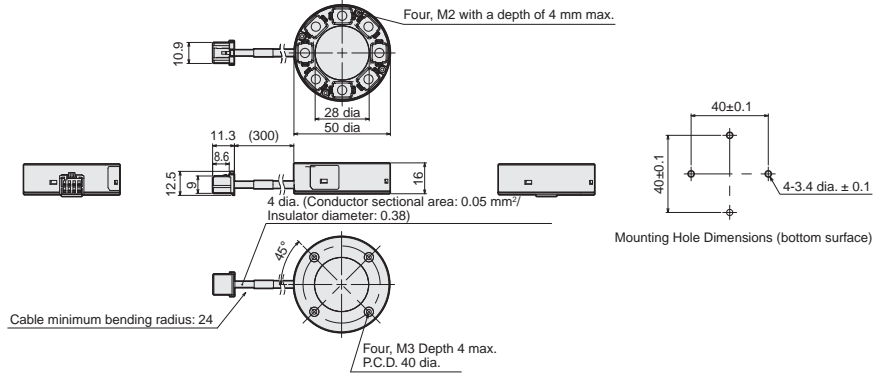

C FL-DR90W(-H)

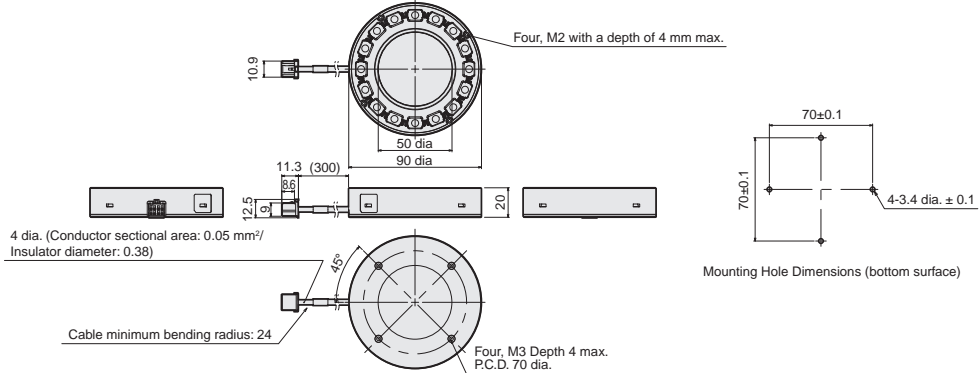

Camera-mount Lighting Controller for FL Series

FL-TCC Series

Standard Models
FLV Series

High-brightness Models
FL Series

**Camera-mount Compact
Lighting Controller Which Requires
No Power Supply Nor Lighting Control**



Product Features

- No separate power supply is required because the power is supplied from the Camera.
- Light is emitted when a trigger signal is received from the Camera.
- Simple connection between the Camera and the Lighting with a single cable.



LED Characteristics

Ordering Information

Item	Model	Weight
Lighting Controller	FL-TCC1	Approx. 110 g
Camera Mounting Spacer	FL-TCC1-XSP	Approx. 10 g
Camera Mounting Attachment	FL-TCC1-XAT	Approx. 20 g

Lenses

Camera-mount Lighting Controller for FL Series FL-TCC Series

Specifications

Lighting Controller

Product type	Lighting Controller	
Model	FL-TCC1	
Input voltage	Supplied from applicable camera.	
Applicable camera	FH-S/SC/S02/SC02/S04/SC04, FZ-S/SC/S2M/SC2M/S5M2/SC5M2/SH/SHC/SF/SFC/SP/SPC, FQ-MS series and others.	
Applicable controller	FH series	
Power consumption	10 W, 0.9 A max. (including the lighting section)	
Number of output channels	1	
Applicable light	FL-□ series	
Luminance control method	Functions	PWM frequency: 100 kHz, Light adjustment: 255 levels (set with the Controller)
	Trigger lighting	Lighting ON synchronized with trigger input timing from the Controller. (Auto setting in accordance with the shutter speed.)
	Trigger lighting delay time	Ton: 30 μs max. (Trigger ready μs) Toff: 10 μs max.
External interface	Dedicated communication connector	
Ambient temperature	Operating: 0 to 50°C, Storage: -15 to 60°C (with no icing or condensation)	
Ambient humidity	Operating/storage: 35% to 85% (with no condensation)	
Vibration resistance	10 to 55 Hz, (0.7 mm double amplitude) 80 min each in X, Y, and Z directions	
Shock resistance	150 m/s ² 3 times each in 6 directions (up/down, left/right, forward/backward)	
Materials	Case: SECC, Cable: PVC	
Degree of protection	IP20 (IEC60529)	
Weight	Approx. 110 g	
Accessories	Instruction sheet, Insulation sheet, Mounting screw (M2 x 6 mm) x 4	
Applicable standards	EN61326-1 *, KC	

* Electromagnetic environment: Industrial electromagnetic environment (EN/IEC 61326-1 Table 2)
Also, the following condition is applied to the immunity test of this product.
There are case that Lighting brightness fluctuate Max 10%.

Dimensions

(Unit:mm)

Lighting Controller FL-TCC1

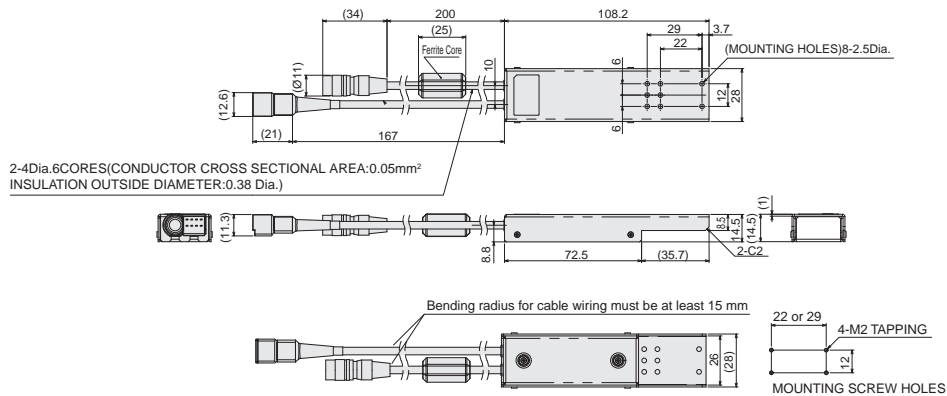

Options

Camera Mounting Spacer FL-TCC1-XSP (sold separately)

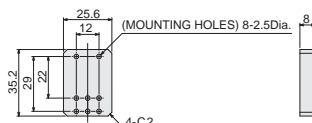

Camera Mounting Attachment FL-TCC1-XAT (sold separately)

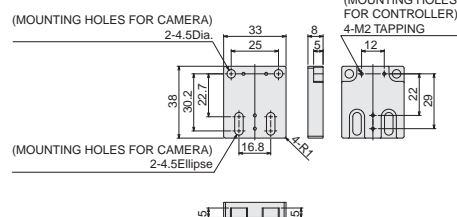

Digital Lighting Controller for FL Series

FL-STC Series

Small body is combined
with the long cable at 25 m.
Install in essentially any location.



Two-channel models

One-channel models

Product Features

Easy Control and Adjustment of the Lighting

With a compact design small enough to fit in the palm of your hand, the Controller can be built into the control panel or in the gap between production lines.

By using the longest lighting cable in the industry (25 m), the Controller can be installed along with the image processing monitor in a variety of locations. It is possible to adjust the lighting while looking at the screen.

Connect to a Remote Control Panel



Mount to a DIN Rail underneath the Line or in the Gap between Tables



Lighting Control without Programming

This enables light emission synchronized with the camera using essentially any trigger, such as a photoelectric sensor.

The Controller can be connected to an image processing device to control lighting without any programming on a PLC.

- [Control Output]
- PNP/NPN models
 - Power source: 24 V

- [Lighting Emission Controls]
- Lighting triggers can be used individually for each channel.
 - Lighting delay and lighting time can be controlled.

Intuitive Digital Light Controls

Digital adjustment of light emission makes it easy to reproduce the lighting environment after line switchovers.



The quantity of light is displayed digitally in 400 levels. Adjust the light in fine detail.

▲ Increases brightness

▼ Decreases brightness

Digital Lighting Controller for FL Series FL-STC Series

Ordering Information

Type	Model	I/O specification	Input voltage
One-channel models	FL-STC10	NPN	24 VDC
	FL-STC15	PNP	
Two-channel models	FL-STC20	NPN	
	FL-STC25	PNP	

Specifications

Product type		One-channel models		Two-channel models	
I/O type		NPN	PNP	NPN	PNP
Model		FL-STC10	FL-STC15	FL-STC20	FL-STC25
Power supply voltage		24 VDC±10% (including ripple)			
Power consumption		36 W, 1.5 A max. (including the lighting section)		72 W, 3 A max. (including the lighting section)	
Number of output channels		1		2	
Applicable light		FL-□ Series			
Luminance control method	CONTINUOUS mode	While the Strobe Controller power source is ON, light is continuously emitted. PWM frequency: 100 kHz, Light adjustment: 400 levels			
	EXTERNAL TRIGGER mode	Lighting in synchronization with an external trigger input. Lighting duration: Continuous while the trigger is input, or 0.1 to 99.9 ms (set in 0.1-ms increments) PWM frequency: 100 kHz, Light adjustment: 400 levels			
	STORBE mode	Lighting in synchronization with the external trigger input, but twice brighter than EXTERNAL TRIGGER mode. Lighting pulse width: 0.01 to 5 ms (light adjustment: 500 levels equivalent)			
Luminance adjustment	Key	Luminance control method and adjustment value: Slide switch and cross key setting			
	I/O	Luminance adjustment value: 9-bit binary input control			
External interface		Parallel I/O connector (D-sub 15-pin), Terminal block (external trigger input with 2 terminals, power source voltage input with 2 terminals)			
Ambient temperature		Operating: 0 to 40°C, Storage: -15 to 60°C (with no icing or condensation)			
Ambient humidity		Operating/storage: 35% to 85% (with no condensation)			
Vibration resistance		10 to 150 Hz (0.7 mm double amplitude), 80 min each in X, Y, and Z directions			
Shock resistance		150 m/s ² 3 times each in 6 direction (up/down, left/right, forward/backward)			
Materials		Case: PC			
Degree of protection		IEC60529 IP20			
Weight		Approx. 100 g			
Accessories		Instruction sheet, Terminal block connector			
Applicable standards		EN61326-1 *, KC			

* Electromagnetic environment: Industrial electromagnetic environment (EN/IEC 61326-1 Table 2)
Also, the following condition is applied to the immunity test of this product.
There are case that Lighting brightness fluctuate Max 10%.

Dimensions

(Unit:mm)

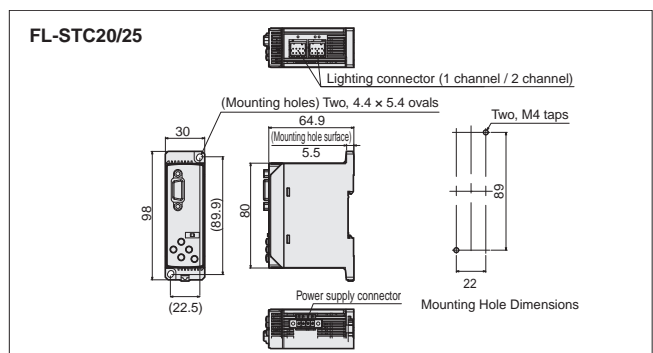
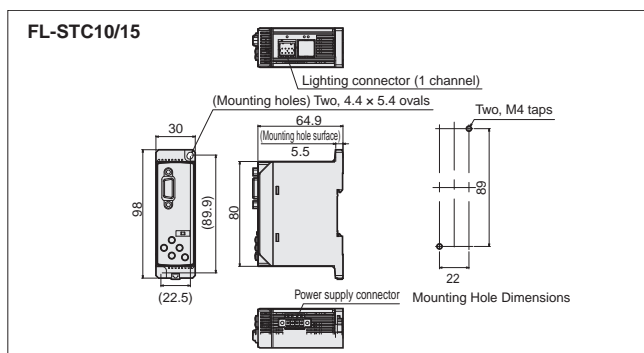

I/O Circuit Diagrams

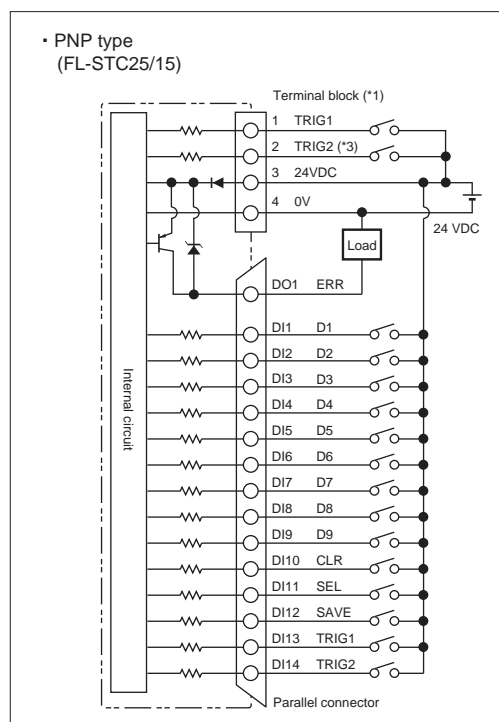
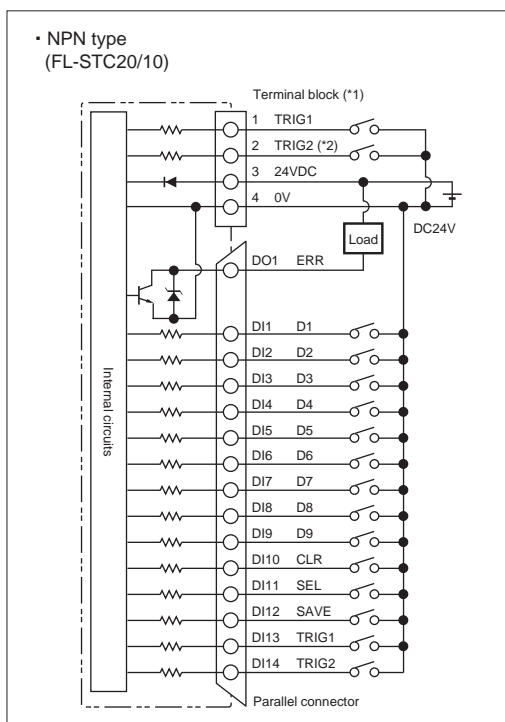

*1. To wire the terminal block, connect a applicable cord (AWG16-22 with a 5 mm margin for work).

*2. No use for FL-STC10

*3. No use for FL-STC15

Electrical Specifications

Output circuit	Input circuit
NPN Open-collector 30 VDC 50 mA max. ON: Residual voltage 1.2 V max. OFF: Leakage current 0.1 mA max.	ON: Short-circuited with 0 V or 1.5 V or less OFF: Open (Leakage current: 0.1 mA max.)

Electrical Specifications

Output circuit	Input circuit
PNP Open-collector 50 mA max. ON: Residual voltage 1.2 V max. OFF: Leakage current 0.1 mA max.	ON: Supply voltage short-circuited or supply voltage within 1.5 v OFF: Open (Leakage current: 0.1 mA max.)

Wiring Diagram

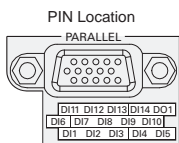

PIN No.	Signal	I/O	Function
DI1	D1	Input	Data 1bit (low)
DI2	D2	Input	Data 2bit
DI3	D3	Input	Data 3bit
DI4	D4	Input	Data 4bit
DI5	D5	Input	Data 5bit
DI6	D6	Input	Data 6bit
DI7	D7	Input	Data 7bit
DI8	D8	Input	Data 8bit
DI9	D9	Input	Data 9bit (High)
DI10	CLR	Input	Error clear. (OFF→ON timing)
DI11	SEL	Input	Select setting CH. OFF=1CH, ON=2CH
DI12	SAVE	Input	Save data D9 - D1 to memory at the timing of "save" OFF→ON *3)
DI13	TRIG1	Input	CH1 Trigger Input (*1)(*2)
DI14	TRIG2	Input	CH2 Trigger Input (*1)(*2)
DO1	ERR	Output	ON at the Error happens

*1. Pin 1 and 2 of terminal block have lighting trigger. Make sure isolate another trigger terminal when you use one trigger terminal.

*2. Prevent from chattering, otherwise the lighting timing would be missed.

*3. Memory function "ON": The data stored in FLASH memory.
Memory function "OFF": The data stored in RAM memory.

Lighting Controller for Photometric Stereo Lights

FL-TCC1PS Series

Lighting controller for photometric stereo lights.



Product Features

- No need to control light emission timing.
- Simple wiring from a vision system controller.
- Light intensity and luminance control are set through the vision system controller.

Specifications

Model	FL-TCC1PS
Applicable vision system controller	FH series (Ver. 6.00 or higher)
Applicable camera	FH-S series, FZ-S series
Applicable light	FL-PS series
Number of channels	1
Power supply voltage *	24 VDC±10% (including ripple)
Recommended power supply	S8VK-G12024 (manufactured by OMRON, 24 VDC, 5 A 120 W)
Current consumption	3.0 A max.
Drive method	Constant voltage method
Luminance control method	Duty light adjustment: light adjustment of 255 levels (configured with vision system controller)
Trigger lighting	Lighting in synchronization with trigger input timing from the controller (configured with vision system controller).
Lighting duration setting	Auto setting in accordance with shutter speed.
Lighting time control	Set with vision system controller or set in accordance with shutter speed.
External interface	Camera connection cable (directly connected with the main unit) 400 mm Lighting connection cable (directly connected with the main unit) 400 mm
Ambient temperature	Operating: 0 to 40°C Storage: -15 to +60°C (with no icing nor no condensation)
Ambient humidity	Operating and storage: 35% to 85% (with no condensation)
Degree of protection	IP20 (IEC60529)
Vibration resistance	10 to 150 Hz, (0.35mm half-amplitude) 80 min. each in X, Y, and Z directions
Shock resistance	150 m/s ² 3 times each in 6 directions (up/down, left/right, forward/backward)
Material	Case: Aluminum, Cable: PVC, Camera Mount Plate: POM
Weight	Approx. 200 g
Accessories	Instruction Sheet (this Sheet), 24 V power supply terminal block (male), camera mount plate, Compliance Sheet, mounting screws (M2 set screw x 4, M2 flat head screw x 4, M4 flat head screw x 4)

- Note: 1. When supplying the power to this lighting controller, make sure to turn ON the power to this lighting controller first or at the same time with the vision system controller.
2. When FL-PS260W is used in the length of the power supply line at least 15m, adjust the power voltage to become 24-26.4 V.
3. This lighting complies with the EN standard (EN61326-1) (Electromagnetic environment : Industrial electromagnetic environment (EN/IEC 61326-1 Table 2))
Also, the following condition is applied to the immunity test of this product.
There are case that Lighting brightness fluctuate Max 10%.
4. This light complies with the KC standard.

Ordering Information

Model
FL-TCC1PS

Dimensions

(Unit:mm)

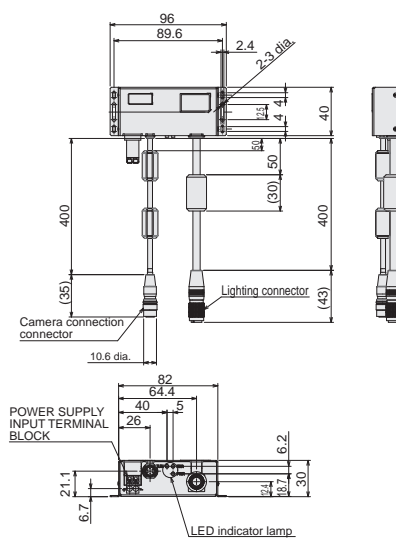

Tightening torque (M2 screw): 0.15 N•m



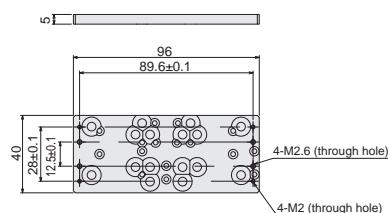

Camera mount plate (provided)



Cable/Diffusion Plate/Mounting Bracket

Cable

Ordering Information

Type	Cable Type	Model	Cable Length	Weight (g)	Drawing
For high-brightness LED lights	Extension Cable, Standard Cable 	FL-XC1	1	Approx. 50	A
		FL-XC2	2	Approx. 80	
		FL-XC3	3	Approx. 120	
		FL-XC5	5	Approx. 190	
		FL-XC10	10	Approx. 400	
		FL-XC25	25	Approx. 1000	
	Extension Cable, Bend resistant Cable 	FL-XC1R	1	Approx. 60	A
		FL-XC2R	2	Approx. 100	
		FL-XC3R	3	Approx. 150	
		FL-XC5R	5	Approx. 240	
		FL-XC10R	10	Approx. 500	
		FL-XC25R	25	Approx. 1200	
For photometric stereo lights	Parallel Cable 	FL-XCP2	2	Approx. 180	B
	Extension Cable between Light and Lighting Controller 	FL-XC05PS	0.5	Approx. 100	C
FL-XC1PS		1	Approx. 150		

Dimensions

(Unit:mm)

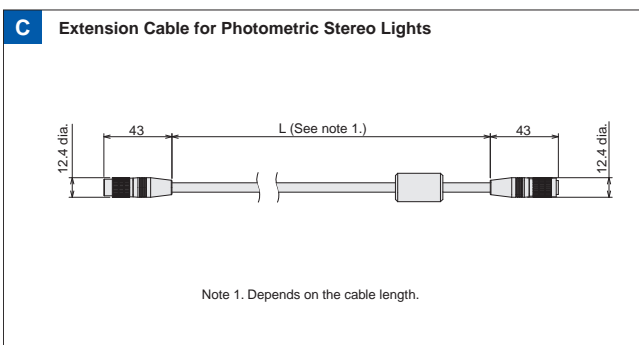
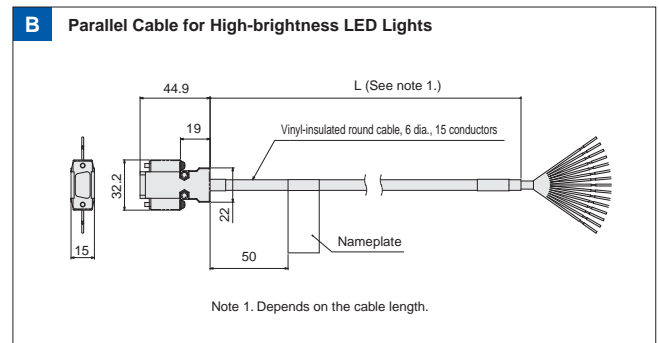
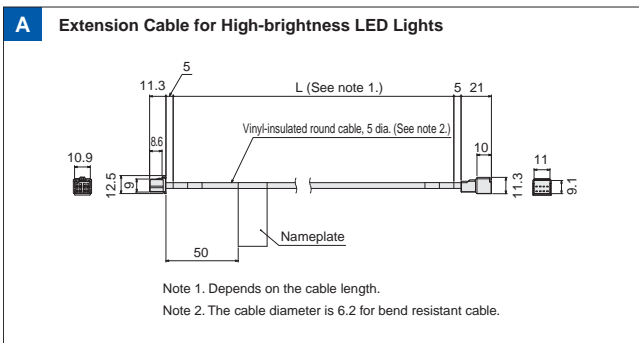

Options for FL Series Cable/Diffusion Plate/Mounting Bracket

Diffusion Plate

Ordering Information



Diffusion Plate

Type	Model	Dimensions (mm)
Bar Lighting	FL-BR5020DF	49.8×18×4
	FL-BR9120DF	90.6×18×4
	FL-BR13120DF	131.4×18×4

Type	Model	Outer diameter/Inner diameter/Thickness (mm)
Direct Ring Lighting	FL-DR32DF	32 dia./10 dia./4
	FL-DR50DF	50 dia./28 dia./4
	FL-DR90DF	90 dia./50 dia./4

Polarization Plate

Type	Model	Outer diameter/Inner diameter/Thickness (mm)
Direct Ring Lighting	FL-DR32PL	32 dia./10 dia./2
	FL-DR50PL	50 dia./28 dia./2
	FL-DR90PL	90 dia./50 dia./2

Mounting Bracket

Ordering Information

Type	Model
Bar Lighting *	FL-XBK1

* One set includes two pieces.
Four mounting screws (M3 × 6 mm) are also included.

Dimensions

(Unit:mm)

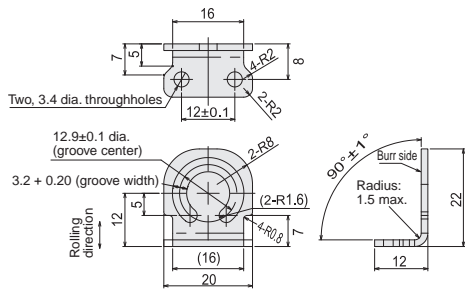

Burrs must extend less than 0.1 mm.

Bracket material: SUS

LED Characteristics

LED Safety

The LEDs that are used in the Light are classified as follows according to IEC 62471.

Series	Shape	Model	Color	LED Safety	Indication
FLV Series	Direct Ring Light	FLV-DR□	White, Blue	Risk Group 2	B
	Direct Ring Light	FLV-DR□	Red, Ultraviolet	Risk Group 1	D
	Direct Ring Light	FLV-DR□IR	Infrared	Risk Group 1	C
	Low Angle Ring Light	FLV-DL□	White, Red, Blue	Risk Group 1	D
	Bar Light	FLV-BR□	White, Blue	Risk Group 2	B
	Bar Light	FLV-BR□	Red, Ultraviolet	Risk Group 1	D
	Bar Light	FLV-BR□IR	Infrared	Risk Group 1	C
	Coaxial Light	FLV-CL□	White, Red, Blue, Ultraviolet	Risk Group 1	D
	Coaxial Light	FLV-CL□IR	Infrared	Risk Group 1	C
	Shadowless Light	FLV-FS□	White, Red, Blue	Risk Group 1	D
	Shadowless Light	FLV-FR□	White, Red, Blue	Risk Group 1	D
	Shadowless Light	FLV-FP□	White, Red, Blue	Risk Group 1	D
	Shadowless Light	FLV-FQ□	White, Red, Blue	Risk Group 1	D
	Direct Back Light	FLV-DB□	White, Red, Blue	Risk Group 1	D
	Edge Type Light	FLV-FB□	White, Red, Blue	Risk Group 1	D
	Edge Type Coaxial Light	FLV-FX□	White, Red, Blue	Risk Group 1	D
	Dome Light	FLV-DD□	White, Red, Blue	Risk Group 1	D
	High-power Spot Light	FLV-EP50□	White, Red	Risk Group 1	D
	Spot Light	FLV-EP08□	White, Red, Blue	Risk Group 1	D
	Line Light	FLV-LN□W	White	Risk Group 3	A
Line Light	FLV-LN□R	Red	Risk Group 1	D	
Line Light	FLV-LN□B	Blue	Risk Group 2	B	
FL Series	MDMC Light	FL-MD180MC	White, Blue, Green	Risk Group 2	B
	MDMC Light	FL-MD180MC	Red	Risk Group 1	D
	MDMC Light	FL-MD90MC	White, Blue	Risk Group 2	B
	MDMC Light	FL-MD90MC	Red, Green	Risk Group 1	D
	Photometric Stereo Light	FL-PS□W	White	Risk Group 2	B
	Direct Ring Light	FL-DR□	White	Risk Group 2	B
	Bar Light	FL-BR□	White	Risk Group 2	B

A

WARNING
Possibly hazardous optical radiation emitted from this product
Risk Group 3 IEC 62471

B

CAUTION
Possibly hazardous optical radiation emitted from this product
Risk Group 2 IEC 62471

C

NOTICE
IR emitted from this product
Risk Group 1 IEC 62471

D

Risk Group 1 IEC 62471

Typical LED Spectral Distributions

Typical spectral distributions and peak wavelengths of each LED color are shown in the diagrams below.

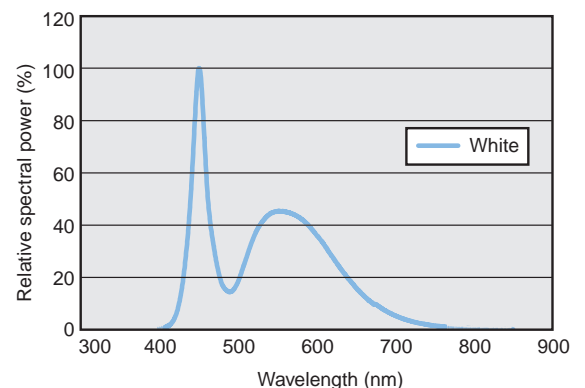
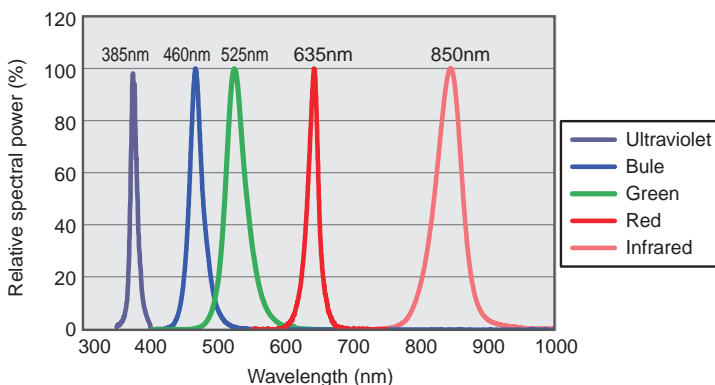

Lens Selection

Standard Models
FLV Series

High-brightness Models
FL Series

LED Characteristics

Lenses

FH/FZ-series Vision System

Camera		Recommended lens		
Resolution	Model	Standard Lens	Telecentric Lens	Vibrations and Shocks Resistant Lens
		Lens for general inspection. Ideal for when a wide field of view, a long working distance, or cost-effectiveness is required.	Lens ideal for high-precision inspection and alignment. Images can be captured at high magnification, and distortion at edges of images is low.	Robust lens with improved resistance to vibrations and shocks is ideal for industrial use. Design without lock screws enables installation in narrow positions.
0.3 million pixels	FZ-SP/SPC/SF/SFC	FZ-LES Series Product details: Page 76 Optical chart: Page 95	VS-TCH Series Product details: Page 77	VS-MCA Series Product details: Page 81 Optical chart: Page 95, 96 VS-MC Series Product details: Page 88
	FZ-S□	SV-V Series Product details: Page 71 Optical chart: Page 91		
	FZ-SH□			
FH-S□				
0.4 million pixels	FH-S□X	SV-V Series Product details: Page 71 Optical chart: Page 91		
1.6 million-pixel	FH-S□X01	SV-H Series Product details: Page 72 Optical chart: Page 92		
2 million pixels	FZ-S□2M	VS-H1 Series Product details: Page 72 Optical chart: Page 93	VS-TEV Series Product details: Page 80	VS-MCH1 Series Product details: Page 84 Optical chart: Page 97
	FH-S□02			
3.2 million-pixel	FH-S□X03	SV-H Series Product details: Page 72 Optical chart: Page 93	VS-TCH Series Product details: Page 77	VS-MCA Series Product details: Page 81 Optical chart: Page 96 VS-MC Series Product details: Page 88
4 million pixels	FH-S□04	VS-H1 Series Product details: Page 72 Optical chart: Page 93	VS-TEV Series Product details: Page 80	VS-MCH1 Series Product details: Page 84 Optical chart: Page 97
5 million pixels	FH-S□05R	SV-H Series Product details: Page 72 Optical chart: Page 92	VS-TCH Series Product details: Page 77	VS-MCA Series Product details: Page 81 Optical chart: Page 96 VS-MC Series Product details: Page 88
	FZ-S□5M3			
	FH-S□X05			
12 million pixels	FH-S□X12	VS-HVA Series Product details: Page 74 Optical chart: Page 94 VS-LDD Series Product details: Page 75 Optical chart: Page 94	VS-TEV Series Product details: Page 80	—
	FH-S□12	VS-L/M42-10 Series Product details: Page 73 Optical chart: Page 93	—	VS-MCL/M42-10 Series Product details: Page 86 Optical chart: Page 97
20.4 million pixels	FH-S□21R	VS-HVA Series Product details: Page 74 Optical chart: Page 94 VS-LDD Series Product details: Page 75 Optical chart: Page 94	VS-TEV Series Product details: Page 80	VS-MCH1 Series Product details: Page 84 Optical chart: Page 97

FHV7-series Smart Camera

Camera		Recommended lens		
Resolution	Model	Standard Lens	Telecentric Lens	Vibrations and Shocks Resistant Lens
		Lens for general inspection. Ideal for when a wide field of view, a long working distance, or cost-effectiveness is required.	Lens ideal for high-precision inspection and alignment. Images can be captured at high magnification, and distortion at edges of images is low.	Robust lens with improved resistance to vibrations and shocks is ideal for industrial use. Design without lock screws enables installation in narrow positions.
0.4 million pixels	FHV7X-□004-C	SV-V Series Product details: Page 71 Optical chart: Page 98	VS-TCH Series Product details: Page 77	VS-MCA Series Product details: Page 81 Optical chart: Page 99, 100 VS-MC Series Product details: Page 88
1.6 million pixels	FHV7X-□016-C	SV-H Series Product details: Page 72 Optical chart: Page 98		
3.2 million pixels	FHV7X-□032-C	SV-H Series Product details: Page 72 Optical chart: Page 98, 99		
5 million pixels	FHV7X-□050-C			
6.3 million pixels	FHV7X-□063R-C			
12 million pixels	FHV7X-□120R-C			

Lens for C-mount Cameras

SV-V Series

- Standard CCTV lens.
- Lineup of 11 models with focal lengths ranging from 3.5 to 100 mm.
- Lock screws for focus and iris.
- More robust structure designed for machine vision.
- Lower distortion and higher resolution than previous CCTV lenses.



Ordering Information

Recommended camera	Model	Dimensions	Focal distance (mm)	Aperture (F No)	Field of view (V × H)	Closest distance (mm)	Filter size	Weight (g)	Total length (mm)	Maximum compatible CCD
FZ-S□ FZ-SH□ FH-S□ FH-S□X FHV7X-□*	3Z4S-LE SV-03514V	A	3.5	1.4 to Close	77.8°×105.9°	200	-	53	30.4	1/3 inch
	3Z4S-LE SV-04514V	B	4.5	1.4 to Close	59.7°×79.9°	200	-	53	29.5	1/3 inch
	3Z4S-LE SV-0614V	C	6	1.4 to Close	42.3°×54.6°	200	M27.0 P0.5	49	30	1/3 inch
	3Z4S-LE SV-0813V	D	8	1.3 to Close	44.6°×57.3°	200	M25.5 P0.5	55	34	1/3 inch
	3Z4S-LE SV-1214V	E	12	1.4 to Close	21.9°×38.9°	300	M27.0 P0.5	44	29.5	1/3 inch
	3Z4S-LE SV-1614V	F	16	1.4 to Close	22.8°×30.1°	400	M27.0 P0.5	34	24	1/3 inch
	3Z4S-LE SV-2514V	G	25	1.4 to Close	14.9°×19.8°	500	M27.0 P0.5	36	24.5	1/3 inch
	3Z4S-LE SV-3518V	H	35	1.8 to Close	10.8°×14.4°	300	M27.0 P0.5	47	33.5 to 37.5	1/3 inch
	3Z4S-LE SV-5018V	I	50	1.8 to Close	7.9°×10.5°	1000	M30.5 P0.5	67	37.0 to 39.4	1/3 inch
	3Z4S-LE SV-7527V	J	75	2.7 to Close	3.6°×4.8°	1000	M30.5 P0.5	76	42.0 to 44.4	1/3 inch
	3Z4S-LE SV-10035V	K	100	3.5 to Close	2.9°×3.8°	1000	M30.5 P0.5	79	43.9 to 6.3	1/3 inch

*The SV-V Series can be used with the FHV7 Smart Camera with 0.4 or 1.6 million pixels.

Dimensions

(Unit:mm)

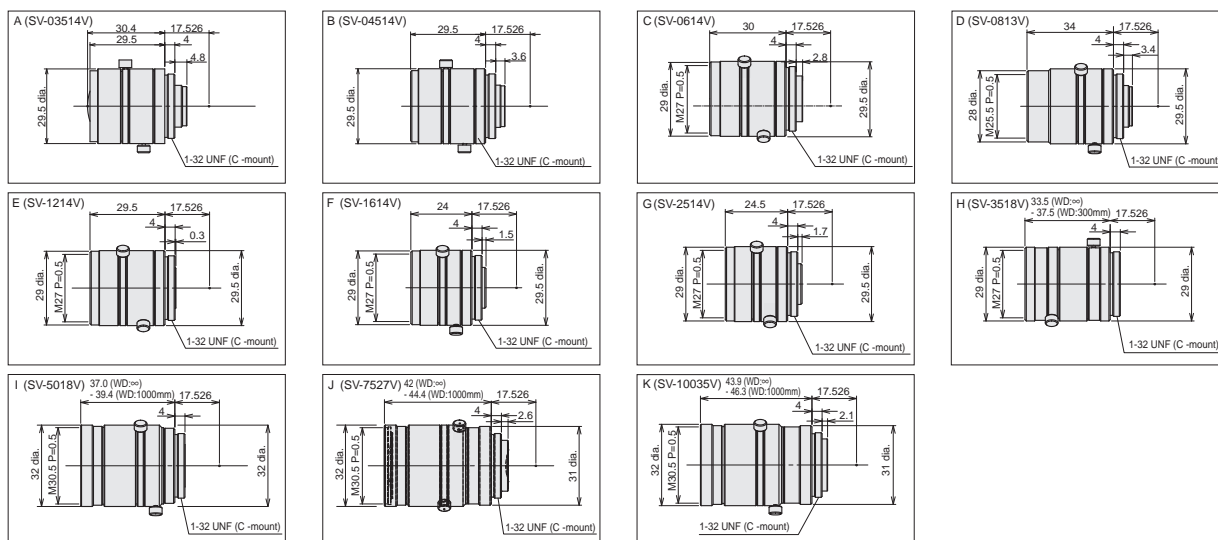

Specifications

Mounting	C mount
Ambient temperature	Operating: 0 to 50°C, Storage: -10 to 60°C (with no icing or condensation)
Ambient humidity	Operating: 35% to 80%, Storage: 35% to 90% (with no condensation)

Optical Chart

Refer to page 91 and 98.

High-resolution Lens for C-mount Cameras

SV-H/V/S-H1 Series

- High-resolution lens for megapixel camera.
- Lineup of 7 models for 2/3-inch cameras, with focal lengths ranging from 6 to 100 mm, and 9 models for 1-inch cameras.
- Lock screws for focus and iris.
- Short expose time with bright F number of 1.4 for high-speed CMOS cameras.
- Compact design but minimized decrease in distortion and brightness.



SV-H Series for 2/3-inch image sensor



VS-H1 Series for 1-inch image sensor

Ordering Information

Recommended camera	Model	Dimensions	Focal distance (mm)	Aperture (F No)	Field of view (V × H)	Closest distance (mm)	Filter size	Weight (g)	Total length (mm)	Maximum compatible CCD
FZ-S□2M FZ-S□5M3 FH-S□05R FH-S□X01 FH-S□X03 FH-S□X05 FHV7X-□	3Z4S-LE SV-0614H	A	6	1.4 to 16	56.8°×71.5°	100	M40.5 P0.5	145	57.5	2/3 inch
	3Z4S-LE SV-0814H	B	8	1.4 to 16	44.9°×57.6°	100	M35.5 P0.5	125	52.5	2/3 inch
	3Z4S-LE SV-1214H	C	12	1.4 to 16	30.2°×39.6°	100	M27 P0.5	85	51	2/3 inch
	3Z4S-LE SV-1614H	D	16	1.4 to 16	23.1°×30.6°	100	M27 P0.5	85	47.5	2/3 inch
	3Z4S-LE SV-2514H	E	25	1.4 to 16	15.0°×20.0°	150	M27 P0.5	65	36	2/3 inch
	3Z4S-LE SV-3514H	F	35	1.4 to 16	10.8°×14.3°	200	M35.5 P0.5	150	45.5	2/3 inch
	3Z4S-LE SV-5014H	G	50	1.4 to 16	7.5°×10.0°	300	M40.5 P0.5	170	57.5	2/3 inch
	3Z4S-LE SV-7525H	H	75	2.5 to Close	8.6°×8.6° *	1200	M34.0 P0.5	85	49.5 to 54.6	1 inch
	3Z4S-LE SV-10028H	I	100	2.8 to Close	6.6°×6.6° *	2000	M37.5 P0.5	105	66.5 to 71.6	1 inch
FH-S□02 FH-S□04	3Z4S-LE VS-0618H1	J	6	1.8 to 16	87.3°×87.3°	100	NA	200	57.2	1 inch
	3Z4S-LE VS-0814H1	K	8	1.4 to 16	71.8°×71.8°	100	M55.0 P0.75	170	59	1 inch
	3Z4S-LE VS-1214H1	L	12	1.4 to 16	50.8°×50.8°	300	M35.5 P0.5	140	48 to 48.5	1 inch
	3Z4S-LE VS-1614H1N	M	16	1.4 to 16	38.6°×38.6°	300	M30.5 P0.5	120	45.0 to 45.9	1 inch
	3Z4S-LE VS-2514H1	N	25	1.4 to 16	25.1°×25.1°	300	M30.5 P0.5	90	33.5 to 35.6	1 inch
	3Z4S-LE VS-3514H1	O	35	1.4 to 16	18.3°×18.3°	300	M30.5 P0.5	100	35.0 to 39.1	1 inch
	3Z4S-LE VS-5018H1	P	50	1.8 to 16	12.8°×12.8°	500	M40.5 P0.5	135	44.5 to 49.5	1 inch

*A field of view captured by a 1-inch CCD.

Note: The FH-S□02/FH-S□04 with a focal length of 75 mm or 100 mm can be used with the 3Z4S-LE SV-7525H or 3Z4S-LE SV-10028H, respectively.

Dimensions

(Unit:mm)

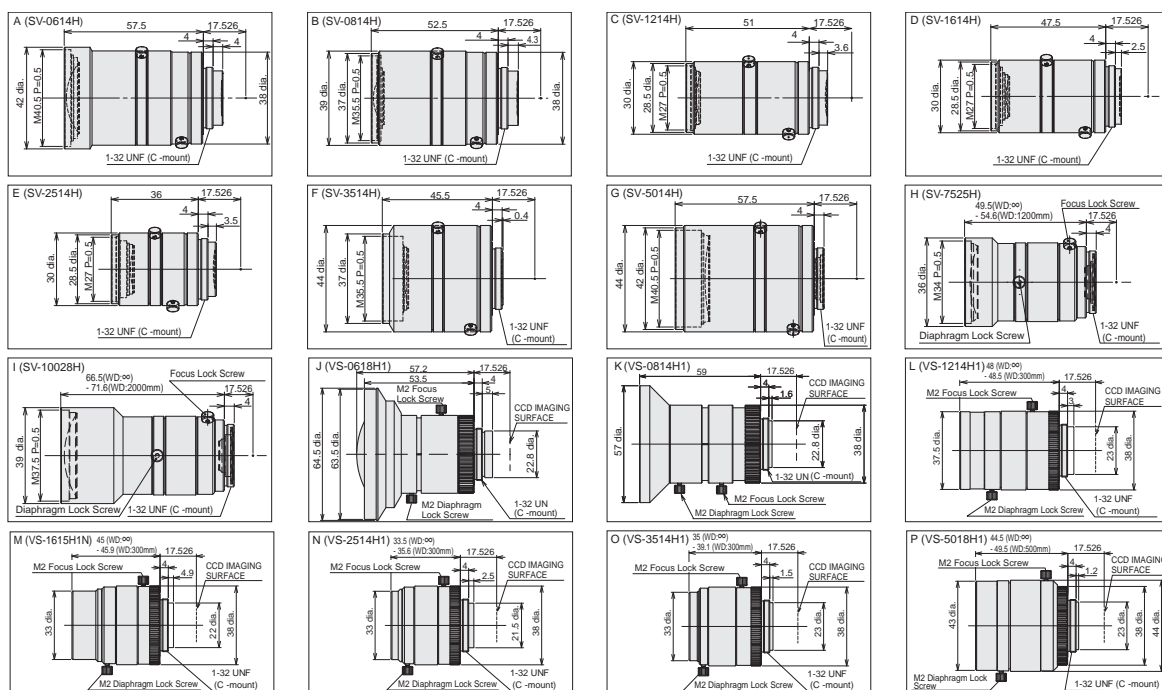

Specifications

Mounting	C mount
Ambient temperature	Operating: 0 to 50°C, Storage: -10 to 60°C (with no icing or condensation)
Ambient humidity	Operating: 35% to 80%, Storage: 35% to 90% (with no condensation)

Optical Chart

Refer to page 92, 93, 98 and 99.

VS-L/M42-10 Series

- Wide variety of lenses with focal lengths ranging from 18 to 100 mm.
- Hexagon socket head cap screws for focus and aperture lock screws can be tightened more than finger tight. This ensures vibration resistance even when large diameter lenses are used.



Ordering Information

Recommended camera	Model	Dimensions	Focal distance (mm)	Aperture (F No)	Optical magnification	Closest distance (mm)	Filter size	Weight (g)	Total length (mm)	Maximum compatible CCD
FH-S□12	3Z4S-LE VS-L1828/M42-10	A	18	2.8 to 16	0.025x to 0.12x	137.9	M55.0 P0.75	330	94	1.8 inches
	3Z4S-LE VS-L2526/M42-10	B	25	2.6 to 16	0.025x to 0.12x	198.1	M55.0 P0.75	240	80	1.8 inches
	3Z4S-LE VS-L3528/M42-10	C	35	2.8 to 16	0.05x to 0.3x	112.8	M62.0 P0.75	345	108	1.8 inches
	3Z4S-LE VS-L5028/M42-10	D	50	2.8 to 16	0.05x to 0.3x	181.4	M62.0 P0.75	285	94.5	1.8 inches
	3Z4S-LE VS-L8540/M42-10	E	85	4.0 to 16	0.1x to 0.35x	285.0	M52.0 P0.75	340	129.5	1.8 inches
	3Z4S-LE VS-L10028/M42-10	F	100	2.8 to 16	0.05x to 0.3x	409.0	M52.0 P0.75	350	134.5	1.8 inches

Note: Vibrations and Shocks Resistant Lenses for M42-mount cameras are also available. Ask your OMRON representative for details.

Dimensions

(Unit:mm)

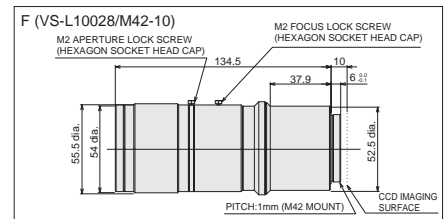
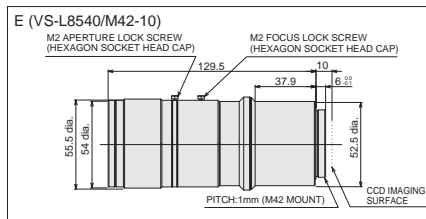
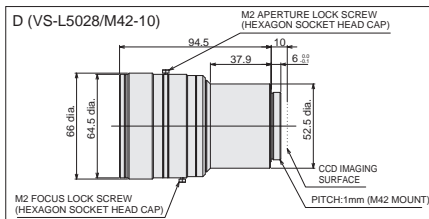
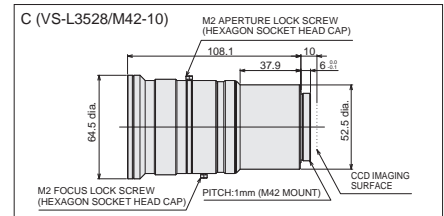
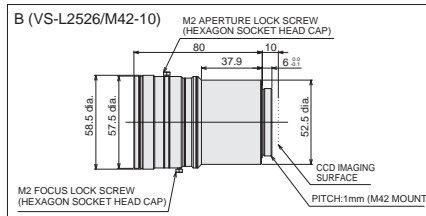
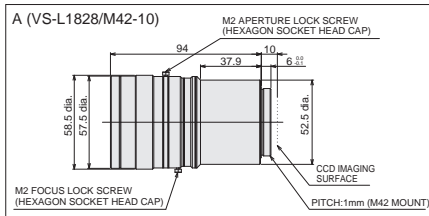

Specifications

Mounting	M42 mount
Ambient temperature	Operating: 0 to 50°C, Storage: -10 to 60°C (with no icing or condensation)
Ambient humidity	Operating: 35% to 80%, Storage: 35% to 90% (with no condensation)

Optical Chart

Refer to page 93.

Ultra-high-resolution Lens for C-mount Cameras

VS-HVA Series

- Ultra-high-resolution lens for 1.1-inch cameras.
- Lineup of 5 models with focal lengths ranging from 12 to 50 mm.
- Low-distortion design to obtain images with high resolution to the edge.
- Compact and lightweight design.



Ordering Information

Recommended camera	Model	Dimensions	Focal distance (mm)	Aperture (F No.)	Field of view (1.1", V × H)	Closest distance (mm)	Filter size	Weight (g)	Total length (mm)	Compatible CCD
FH-S□X12 FH-S□21R	3Z4S-LE VS-HVA1226	A	12	2.6 to Close	45.6°×60.0°	100	M34 P=0.5	126	51.2	1.1 inches
	3Z4S-LE VS-HVA1626	B	16	2.6 to Close	35.1°×46.8°	100	M30 P=0.5	128	50	
	3Z4S-LE VS-HVA2524	C	25	2.4 to Close	23.1°×31.3°	100	M35.5 P=0.5	116	45	
	3Z4S-LE VS-HVA3522	D	35	2.2 to Close	16.7°×22.7°	200	M34 P=0.5	122	48.5	
	3Z4S-LE VS-HVA5024	E	50	2.4 to Close	12.0°×16.4°	200	M30.5 P=0.5	142	57.5	

Dimensions

(Unit:mm)

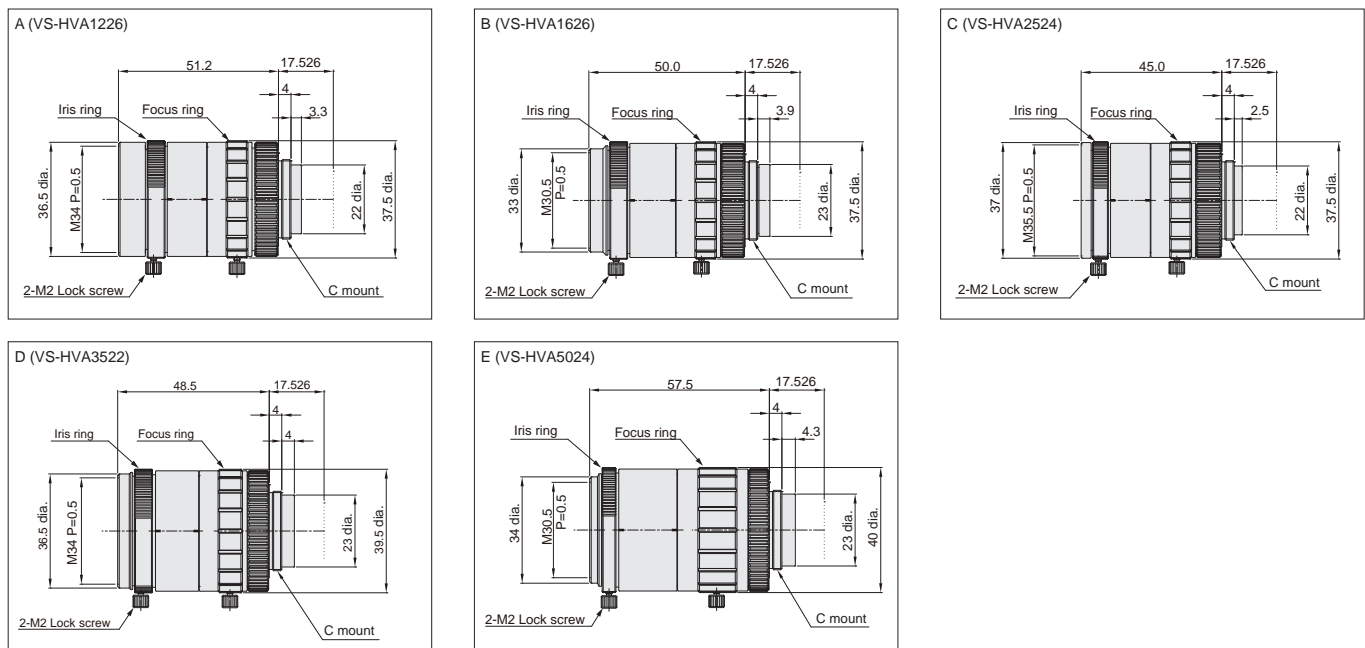

Specifications

Mounting	C mount
Ambient temperature	Operating: -5 to 50°C, Storage: -10 to 60°C (with no icing or condensation)
Ambient humidity	Operating: 0% to 80%, Storage: 0% to 90% (with no condensation)

Optical Chart

Refer to page 94.

Ultra-high-resolution Lens for C-mount Cameras

VS-LLD Series

- Ultra-high-resolution lens for 4/3-inch cameras.
- Lineup of 5 models with focal lengths ranging from 12.5 to 50 mm.
- Leverages the floating mechanism to enable image capture at all ranges.
- Lock screws for focus and iris.
- Low-distortion design to obtain images with high resolution to the edge.



Ordering Information

Recommended camera	Model	Dimensions	Focal distance (mm)	Aperture (F No)	Field of view (V × H)		Closest distance (mm)	Filter size	Weight (g)	Total length (mm)	Maximum compatible CCD
					FH-S□X12	FH-S□21R					
FH-S□X12 FH-S□21R	3Z4S-LE VS-LLD12.5	A	12.5	2.5 to 16	45.1°×58.8°	39.0°×56.0°	40.9	M62 P0.75	380	84.3 to 86.1	4/3 inches
	3Z4S-LE VS-LLD18	B	18	2.1 to 16	32.2°×42.8°	27.6°×40.6°	53.8	M43 P0.75	320	82.3 to 83.8	
	3Z4S-LE VS-LLD25	C	25	2.1 to 16	23.4°×31.5°	20.1°×29.8°	66.0	M43 P0.75	285	82.8 to 84.9	
	3Z4S-LE VS-LLD35	D	35	2.2 to 16	16.9°×22.8°	14.4°×21.5°	129.5	M46 P0.75	295	82.5	
	3Z4S-LE VS-LLD50	E	50	2.2 to 16	11.8°×16.1°	10.1°×15.2°	205.4	M46 P0.75	250	73.0	

Dimensions

(Unit:mm)

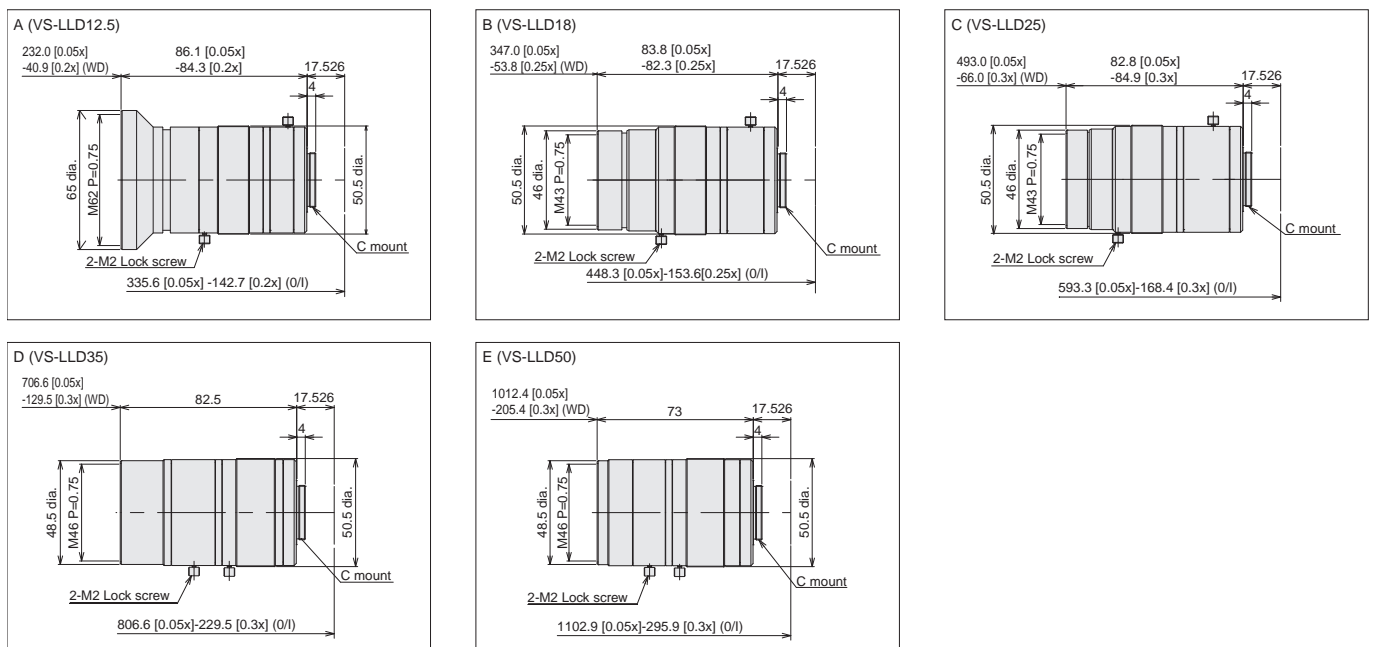

Specifications

Mounting	C mount
Ambient temperature	Operating: -5 to 50°C, Storage: -10 to 60°C (with no icing or condensation)
Ambient humidity	Operating: 0% to 80%, Storage: 0% to 90% (with no condensation)

Optical Chart

Refer to page 94.

Lens for FZ-series Small Cameras

FZ-LES Series

- Product lineup includes two types of small camera lenses, a pen type with a 12-mm diameter and a flat type with a 17-mm thickness.



Ordering Information

Recommended cameras	Model	Focal length (mm)	Aperture (F No.)
FZ-SF□ FZ-SP□	FZ-LES3	3	2.0 to 16
	FZ-LES6	6	2.0 to 16
	FZ-LES16	16	3.4 to 16
	FZ-LES30	30	3.4 to 16

Dimensions

(Unit:mm)

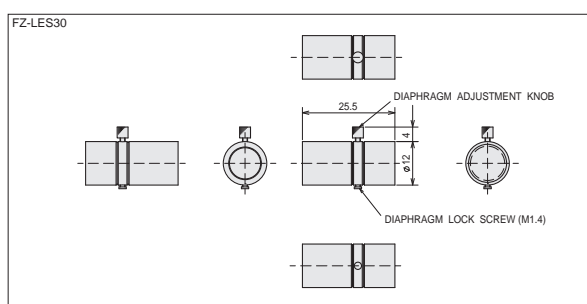
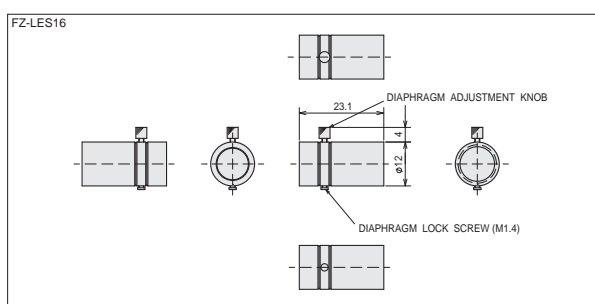
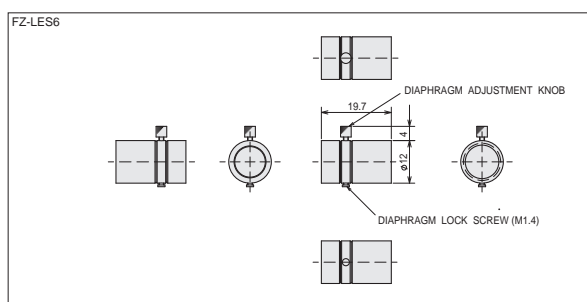
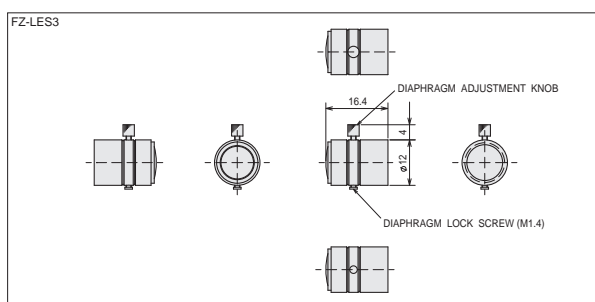

Specifications

Ambient temperature	Operating: -10 to 50°C, Storage: -20 to 70°C (with no icing or condensation)
Ambient humidity	Operating: 0% to 90%, Storage: 0% to 70% (with no condensation)

Optical Chart

Refer to page 95.

High-resolution Telecentric Lens for C-mount Cameras

VS-TCH Series

- High-resolution telecentric lens for megapixel camera.
- Broad product selection.

Available in two different working distances, 65 or 110 mm, to fit installation spaces.
Comes in two shapes: straight and coaxial for coaxial lights.
Five optical magnifications, 0.5x, 1.0x, 1.5x, 2.0x, and 4.0x, are available to cover a wide range of applications.

- Low-distortion design.

High quality images can be obtained from any part of the area.
Ideal for high-precision alignment.



Ordering Information

Recommended camera	Model	Dimensions	Optical magnification (±5%)	WD *1 (mm)	Effective FNO	Depth of field *2 (mm)	Resolution *3 (μm)	TV distortion	Shape	Weight (g)	Maximum compatible CCD
FZ-S□ FZ-SH□ FH-S□ FH-S□X FZ-S□2M FZ-S□5M3 FH-S□05R FH-S□X05 FHV7X-□	3Z4S-LE VS-TCH05-65-O	A	0.5x	75.3	9.42	3	12.43	0.02%	Straight	70	2/3 inch
	3Z4S-LE VS-TCH05-65CO-O	B							Coaxial	80	
	3Z4S-LE VS-TCH05-110-O	C		110.8	9.49	3.04	12.9	0.02%	Straight	100	
	3Z4S-LE VS-TCH05-110CO-O	D							Coaxial	110	
	3Z4S-LE VS-TCH1-65-O	E	1.0x	68.8	9.94	0.8	6.71	0.01%	Straight	70	
	3Z4S-LE VS-TCH1-65CO-O	F							Coaxial	80	
	3Z4S-LE VS-TCH1-110-O	G		110.3	10.49	0.84	6.99	0.02%	Straight	100	
	3Z4S-LE VS-TCH1-110CO-O	H							Coaxial	110	
	3Z4S-LE VS-TCH1.5-65-O	I	1.5x	65	11.8	0.4	5.24	0.01%	Straight	70	
	3Z4S-LE VS-TCH1.5-65CO-O	J							Coaxial	80	
	3Z4S-LE VS-TCH1.5-110-O	K		110.8	11.97	0.43	5.33	0.02%	Straight	90	
	3Z4S-LE VS-TCH1.5-110CO-O	L							Coaxial	105	
	3Z4S-LE VS-TCH2-65-O	M	2.0x	65	13.6	0.3	4.53	0.03%	Straight	70	
	3Z4S-LE VS-TCH2-65CO-O	N							Coaxial	80	
	3Z4S-LE VS-TCH2-110-O	O		110.8	13.5	0.27	4.53	0.03%	Straight	95	
	3Z4S-LE VS-TCH2-110CO-O	P							Coaxial	110	
	3Z4S-LE VS-TCH4-65-O	Q	4.0x	65	17.91	0.09	3	0.02%	Straight	90	
	3Z4S-LE VS-TCH4-65CO-O	R							Coaxial	100	
	3Z4S-LE VS-TCH4-110-O	S		110.8	22.2	0.11	3.73	0.03%	Straight	100	
	3Z4S-LE VS-TCH4-110CO-O	T							Coaxial	110	

*1. The working distance is the distance from the end of the lens to the workpiece.

*2. The depth of field is calculated using a permissible circle of confusion diameter of 0.04 mm.

*3. The resolution is calculated using a wavelength of 550 nm.

Note: 1. Fixing the lens or other reinforcement may be required depending on the installation angle or operating environment (vibration/shock).
When fixing the lens, insulate the lens from the fixture.

2. The above specifications are values calculated from the optical design and can vary depending on installation conditions.

Camera and Field of View Table

Camera	Size of image element (inch)	Imaging area H × V (mm)	Field of view H × V (mm)				
			0.5 × (VS-TCH05)	1.0 × (VS-TCH1)	1.5 × (VS-TCH1.5)	2.0 × (VS-TCH2)	4.0 × (VS-TCH4)
FH-S□/FZ-S□/FZ-SH□	1/3" equivalent	4.8 × 3.6	9.6 × 7.2	4.8 × 3.6	3.2 × 2.4	2.4 × 1.8	1.2 × 0.9
FH-S□X	1/2.9" equivalent	5.0 × 3.8	10.0 × 7.6	5.0 × 3.8	3.3 × 2.5	2.5 × 1.9	1.3 × 1.0
FH-S□05R	1/2.5" equivalent	5.7 × 4.3	11.4 × 8.6	5.7 × 4.3	3.8 × 2.9	2.9 × 2.2	1.4 × 1.1
FZ-S□2M	1/1.8" equivalent	7.0 × 5.3	14.0 × 10.6	7.0 × 5.3	4.7 × 3.5	3.5 × 2.7	1.8 × 1.3
FH-S□X05/FZ-S□5M3	2/3" equivalent	8.4 × 7.1	16.8 × 14.2	8.4 × 7.1	5.6 × 4.7	4.2 × 3.6	2.1 × 1.8
FHV7X-□004-C	1/2.9" equivalent	5.0×3.8	10.0×7.6	5.0×3.8	3.3×2.5	2.5×1.9	1.3×1.0
FHV7X-□016-C	1/2.9" equivalent	5.0×3.8	10.0×7.6	5.0×3.8	3.3×2.5	2.5×1.9	1.3×1.0
FHV7X-□032-C	1/1.8" equivalent	7.1×5.3	14.2×10.6	7.1×5.3	4.7×3.5	3.6×2.7	1.8×1.3
FHV7X-□050-C	2/3" equivalent	8.5×7.1	17.0×14.2	8.5×7.1	5.7×4.7	4.3×3.6	2.1×1.8
FHV7X-□063R-C	1/1.8" equivalent	7.4×5.0	14.8×10.0	7.4×5.0	4.9×3.3	3.7×2.5	1.9×1.3
FHV7X-□120R-C	1/1.7" equivalent	7.4×5.6	14.8×11.2	7.4×5.6	4.9×3.3	3.7×2.8	1.9×1.4

Note: The field of view is a calculated value and not a guaranteed value.

High-resolution Telecentric Lens for C-mount Cameras VS-TCH Series

Applications

Detection of alignment marks

Combining the FLV-EP08-series Spot Light and Camera-mount Lighting Controller saves space and simplifies wiring.

Illustration of Combination of Spot Light and Controller

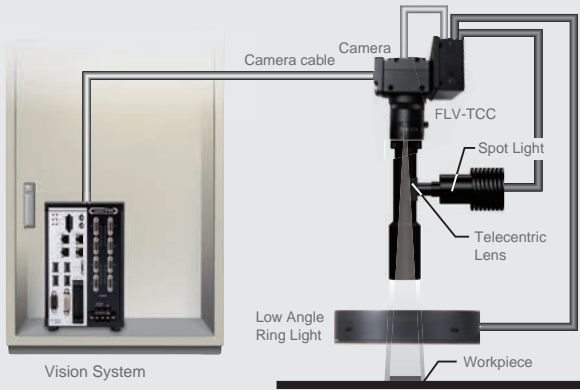

Only the camera cable is connected from control panel

Illustration of Alignment Mark Detection

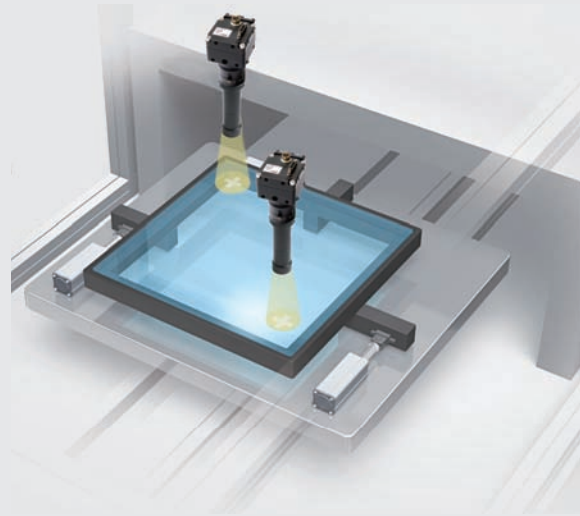

Dimensions

(Unit: mm)

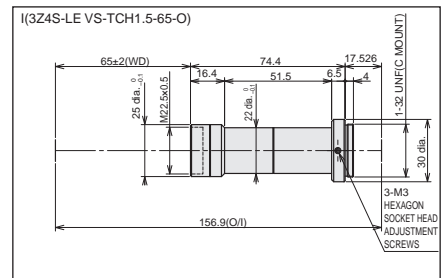
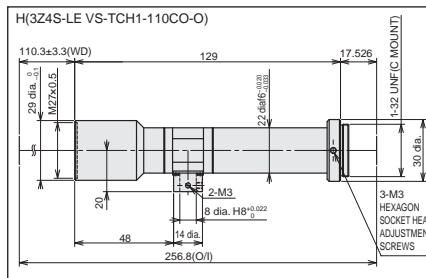
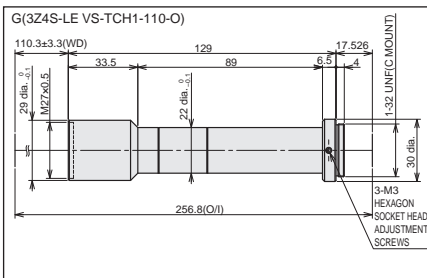
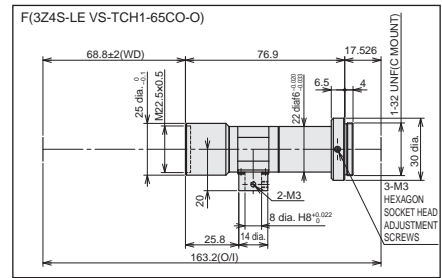
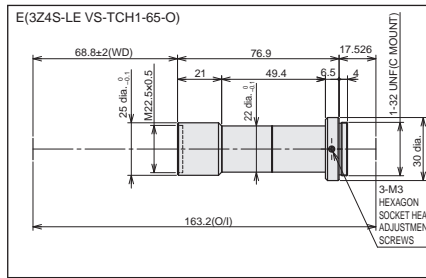
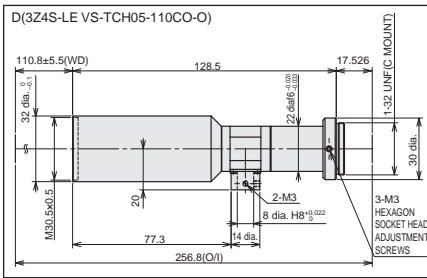
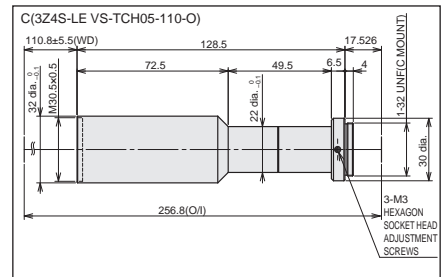
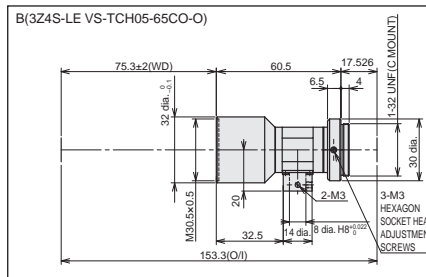
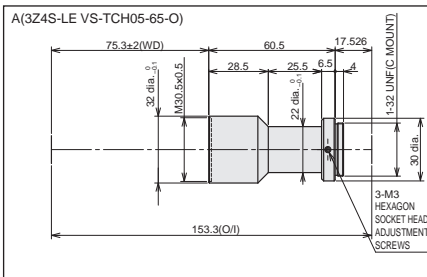

Standard Models
FLV Series

High-brightness Models
FL Series

LED Characteristics

Lenses

High-resolution Telecentric Lens for C-mount Cameras VS-TCH Series

Dimensions

(Unit: mm)

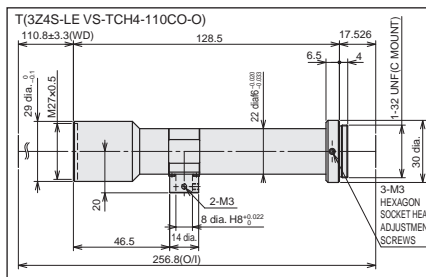
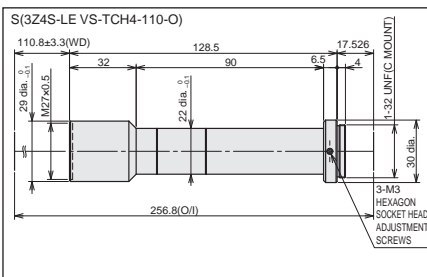
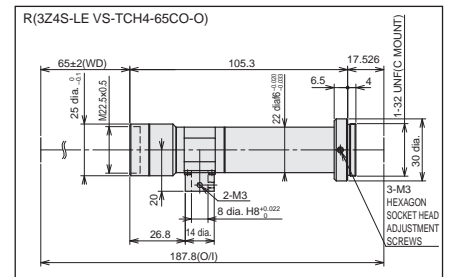
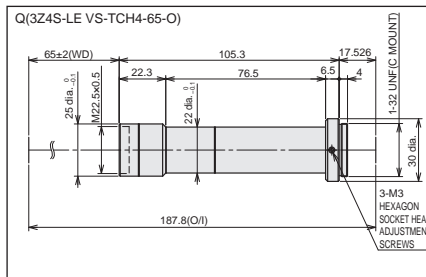
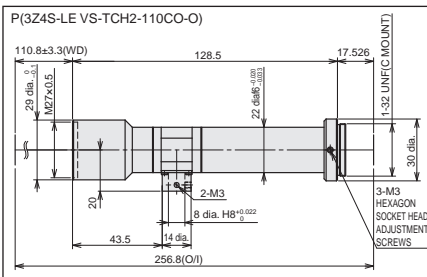
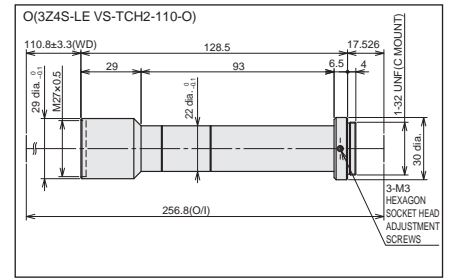
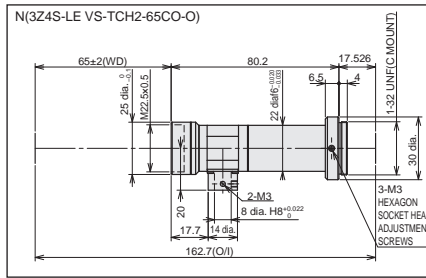
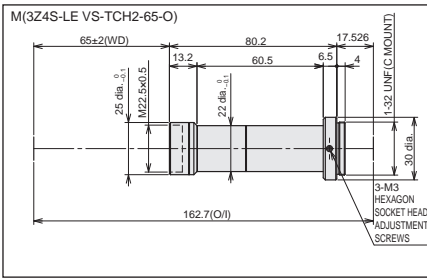
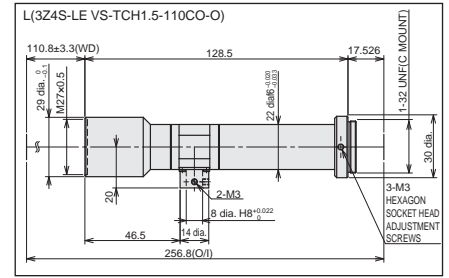
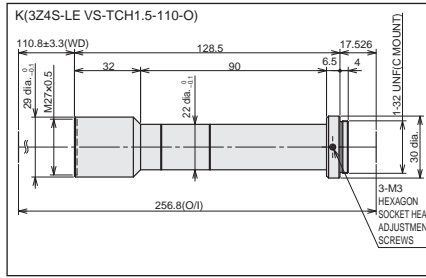
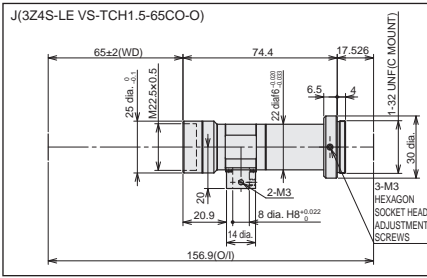

Specifications

Ambient temperature	Operating: 0 to 50°C, Storage: -10 to 60°C (with no icing or condensation)
Ambient humidity	Operating: 35% to 80%, Storage: 35% to 90% (with no condensation)

Standard Models
FLV Series

High-brightness Models
FL Series

LED Characteristics

Lenses

Ultra-high-resolution Telecentric Lens for C-mount Cameras

VS-TEV Series

Standard Models
FLV Series

High-brightness Models
FL Series

LED Characteristics

Lenses

- Ultra-high-resolution telecentric lens for 1.1-inch cameras.
- Lineup of 3 models to meet various optical magnification requirements.
- Variable magnification for use at a wide range of working distances. Balance between depth of field and contrast can be adjusted.
- Low-distortion design.
- High-quality images can be obtained from any part of the area.
- Ideal for high-accuracy alignment.



Ordering Information

Recommended camera	Model	Dimensions	Optical magnification	WD *1 (mm)	Effective FNO * Maximum aperture	Depth of field *2 (mm)	Resolution *3 (mm)	TV distortion	Weight (g)	Maximum compatible CCD
FH-S□02 FH-S□04 FH-S□X12 FH-S□21R	3Z4S-LE VS-TEV0305	A	0.3 ×	221.5	4.3	3.8	9.59	0.03%	390	1.1 inches
			0.4 ×	162.0	5.3	2.6	8.83	-0.04%		
			0.5 ×	125.8	6.2	2.0	8.39	-0.04%		
	3Z4S-LE VS-TEV05075	B	0.5 ×	173.2	5.0	1.6	6.71	0.06%	350	
			0.75 ×	133.9	6.8	1.0	6.10	0.04%		
			0.75 ×	133.9	6.8	1.0	6.10	0.04%		
3Z4S-LE VS-TEV07510	C	0.75 ×	133.9	6.8	1.0	6.10	0.04%	370		
		1.0 ×	114.0	8.5	0.7	5.69	0.02%			

*1. The working distance is the distance from the end of the lens to the workpiece.

*2. The depth of field is calculated using a permissible circle of confusion diameter of 0.04 mm.

*3. The resolution is calculated using a wavelength of 550 nm.

Camera and Field of View Table

Camera	Size of image element (inch)	Imaging area H × V (mm)	Field of view H × V (mm)			
			0.3 × (VS-TEV0305)	0.5 × (VS-TEV0305/VS-TEV05075)	0.75 × (VS-TEV05075/VS-TEV-07510)	1.0 × (VS-TEV07510)
FH-S□02	2/3" equivalent	11.3 × 6.0	37.5 × 19.9	22.5 × 12.0	15.0 × 8.0	11.3 × 6.0
FH-S□04	1" equivalent	11.3 × 11.3	37.5 × 37.5	22.5 × 22.5	15.0 × 15.0	11.3 × 11.3
FH-S□X12	1.1" equivalent	14.1 × 10.4	47.1 × 34.5	28.2 × 20.7	18.8 × 13.8	14.1 × 10.4
FZ-S□21R	1" equivalent	13.3 × 8.9	44.4 × 29.6	26.6 × 17.7	17.7 × 11.8	13.3 × 8.9

Note: The field of view is a calculated value and not a guaranteed value.

Dimensions

(Unit: mm)

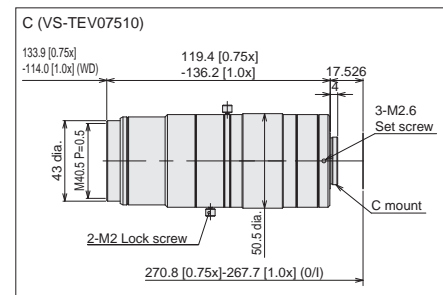
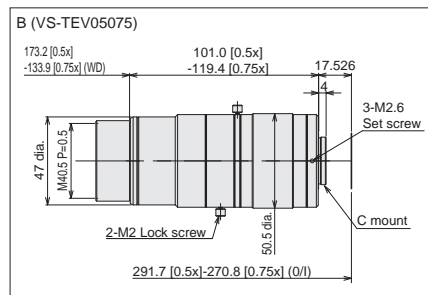
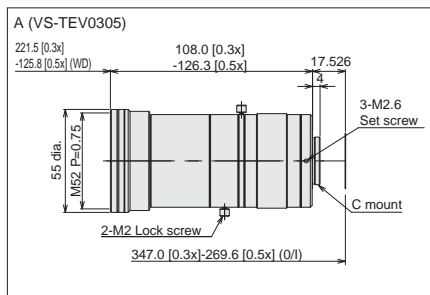

Specifications

Mounting	C mount
Ambient temperature	Operating: -5 to 50°C, Storage: -10 to 60°C (with no icing or condensation)
Ambient humidity	Operating: 0% to 80%, Storage: 0% to 90% (with no condensation)

Vibrations and Shocks Resistant Lens for C-mount Cameras

VS-MCA Series

- Vibrations and shocks resistant lens for megapixel C-mount cameras.
- Lineup of 10 models with focal lengths ranging from 4 to 75 mm.
- The increased resistance to vibration enables application in environments where the lens is moved and where ambient vibrations occur.
- Install in narrow space without a lock screw.
- The hexagonal lock ring makes tightening easier.



Ordering Information

Recommended camera	Model	Dimensions	Focal distance (mm)	Aperture (fixed F No.)	Maximum outer diameter (mm)	Total length (mm)	Filter size	WD (mm)	Depth of field * (mm)	Maximum compatible CCD	
FZ-S□ FZ-SH□ FH-S□ FH-S□X FH-S□X01 FH-S□X03 FH-S□05R FHV7X-□	3Z4S-LE VS-MCA4	A	4	2	31 dia.	29.0 to 29.2	M27.0 P0.5	403.2 196.2 92.7	1680.0 420.0 105.0	1/2 inch	
	3Z4S-LE VS-MCA4-F5.6			5.6	31 dia.	29.0 to 29.2	M27.0 P0.5	403.2 196.2 92.7	4560.0 1140.0 290.0		
	3Z4S-LE VS-MCA4-F8			8	31 dia.	29.0 to 29.2	M27.0 P0.5	403.2 196.2 92.7	6480.0 1640.0 415.0		
	3Z4S-LE VS-MCA6.5	B	6.5	2	31 dia.	23.1 to 23.4	M27.0 P0.5	656.0 209.6 98.0	1840.0 204.4 51.1	1/2 inch	
				3Z4S-LE VS-MCA6.5-F5.6	5.6	31 dia.	23.1 to 23.4	M27.0 P0.5	656.0 209.6 98.0		4560.0 515.6 131.1
				3Z4S-LE VS-MCA6.5-F8	8	31 dia.	23.1 to 23.4	M27.0 P0.5	656.0 209.6 98.0		6480.0 728.9 188.9
	3Z4S-LE VS-MCA10	C	10	2	31 dia.	24.2 to 25.5	M27.0 P0.5	504.1 94.0 59.9	460.0 19.2 9.2	1/2 inch	
				3Z4S-LE VS-MCA10-F5.6	5.6	31 dia.	24.2 to 25.5	M27.0 P0.5	504.1 94.0 59.9		1140.0 49.6 22.8
				3Z4S-LE VS-MCA10-F8	8	31 dia.	24.2 to 25.5	M27.0 P0.5	504.1 94.0 59.9		1640.0 70.4 32.7
FZ-S□ FZ-SH□ FH-S□ FH-S□X FZ-S□2M FZ-S□5M3 FH-S□05R FH-S□X05	3Z4S-LE VS-MCA15	D	15	2	31 dia.	27.9 to 32.0	M27.0 P0.5	490.7 65.4 40.3	186.7 4.8 2.3	2/3 inch	
	3Z4S-LE VS-MCA15-F5.6			5.6	31 dia.	27.9 to 32.0	M27.0 P0.5	490.7 65.4 40.3	515.6 13.4 6.5		
				3Z4S-LE VS-MCA15-F8	8	31 dia.	27.9 to 32.0	M27.0 P0.5	490.7 65.4 40.3		728.9 19.2 9.2

Vibrations and Shocks Resistant Lens for C-mount Cameras VS-MCA Series

Recommended camera	Model	Dimensions	Focal distance (mm)	Aperture (fixed F No.)	Maximum outer diameter (mm)	Total length (mm)	Filter size	WD (mm)	Depth of field * (mm)	Maximum compatible CCD
Standard Models FLV Series	3Z4S-LE VS-MCA20	E	20	2	31 dia.	24.5 to 32.0	M27.0 P0.5	516.8	105.0	2/3 inch
								81.8	3.2	
								50.7	1.5	
	3Z4S-LE VS-MCA20-F5.6			5.6	31 dia.	24.5 to 32.0	M27.0 P0.5	516.8	290.0	
								81.8	9.0	
								50.7	3.9	
	3Z4S-LE VS-MCA20-F8			8	31 dia.	24.5 to 32.0	M27.0 P0.5	516.8	415.0	
								81.8	12.8	
								50.7	5.6	
High-brightness Models FL Series	3Z4S-LE VS-MCA25	F	25	2	31 dia.	27.0 to 38.5	M27.0 P0.5	514.6	67.2	2/3 inch
								106.6	3.2	
								55.6	1.0	
	3Z4S-LE VS-MCA25-F5.6			5.6	31 dia.	27.0 to 38.5	M27.0 P0.5	514.6	188.8	
								106.6	9.0	
								55.6	2.7	
	3Z4S-LE VS-MCA25-F8			8	31 dia.	27.0 to 38.5	M27.0 P0.5	514.6	268.8	
								106.6	12.8	
								55.6	3.8	
LED Characteristics	3Z4S-LE VS-MCA30	G	30	2	31 dia.	24.5 to 36.2	M27.0 P0.5	513.5	53.3	2/3 inch
								213.5	8.2	
								80.1	1.3	
	3Z4S-LE VS-MCA30-F5.6			5.6	31 dia.	24.5 to 36.2	M27.0 P0.5	513.5	131.1	
								213.5	22.8	
								80.1	3.2	
	3Z4S-LE VS-MCA30-F8			8	31 dia.	24.5 to 36.2	M27.0 P0.5	513.5	188.9	
								213.5	32.7	
								80.1	4.6	
Lenses	3Z4S-LE VS-MCA35	H	35	2	31 dia.	32.0 to 45.7	M27.0 P0.5	163.9	3.0	2/3 inch
								145.9	2.2	
								83.1	0.7	
	3Z4S-LE VS-MCA35-F5.6			5.6	31 dia.	32.0 to 45.7	M27.0 P0.5	163.9	8.4	
								145.9	6.5	
								83.1	1.7	
	3Z4S-LE VS-MCA35-F8			8	31 dia.	32.0 to 45.7	M27.0 P0.5	163.9	12.0	
								145.9	9.2	
								83.1	2.5	
Lenses	3Z4S-LE VS-MCA50	I	50	2	31 dia.	44.0 to 63.4	M27.0 P0.5	633.6	32.5	2/3 inch
								270.1	6.0	
								128.7	1.3	
	3Z4S-LE VS-MCA50-F5.6			5.6	31 dia.	44.0 to 63.4	M27.0 P0.5	633.6	75.0	
								270.1	13.4	
								128.7	2.9	
	3Z4S-LE VS-MCA50-F8			8	31 dia.	44.0 to 63.4	M27.0 P0.5	633.6	107.5	
								270.1	19.2	
								128.7	4.1	
Lenses	3Z4S-LE VS-MCA75	J	75	2	31 dia.	70.0 to 105.5	M27.0 P0.5	562.9	16.7	2/3 inch
								404.4	9.2	
								153.8	1.3	
	3Z4S-LE VS-MCA75-F5.6			5.6	31 dia.	70.0 to 105.5	M27.0 P0.5	562.9	28.6	
								404.4	13.4	
								153.8	2.5	
	3Z4S-LE VS-MCA75-F8			8	31 dia.	70.0 to 105.5	M27.0 P0.5	562.9	41.2	
								404.4	19.2	
								153.8	3.6	

Note: Vibrations and Shocks Resistant Lenses for 1-inch image sensors are also available. Ask your OMRON representative for details.

* Calculated using a permissible circle of confusion diameter of 0.04 mm.

Vibrations and Shocks Resistant Lens for C-mount Cameras VS-MCA Series

Dimensions

(Unit:mm)

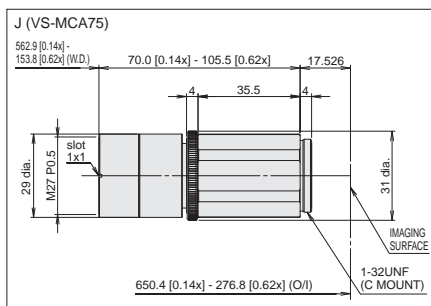
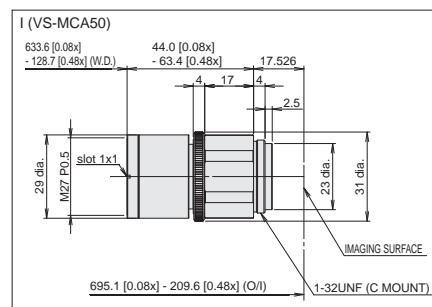
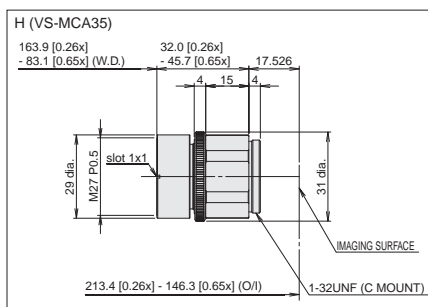
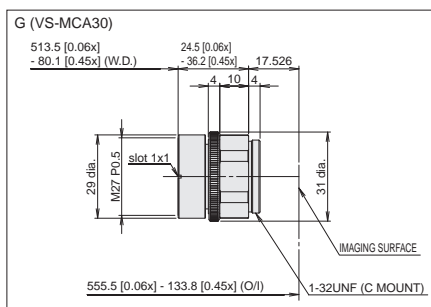
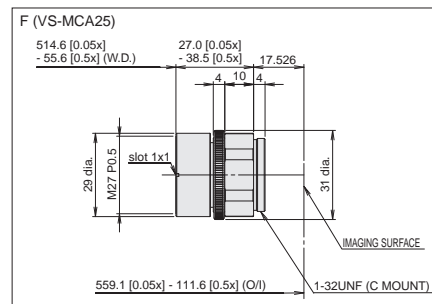
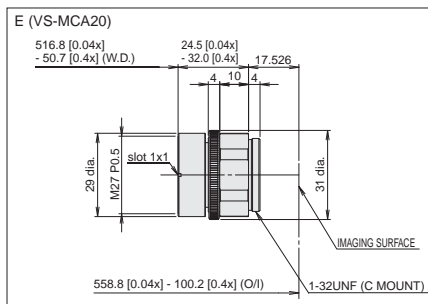
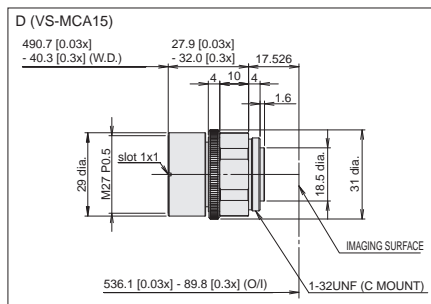
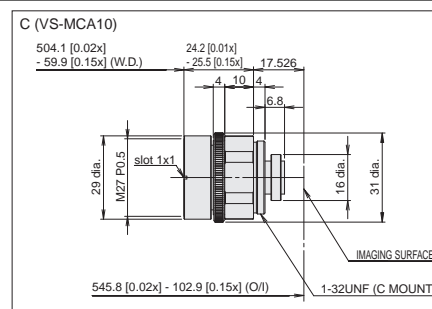
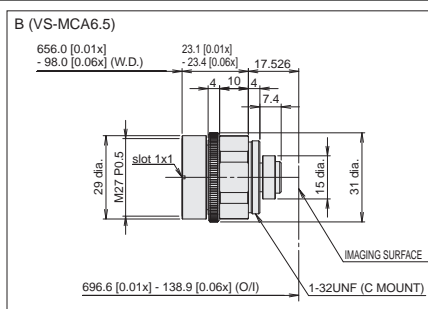
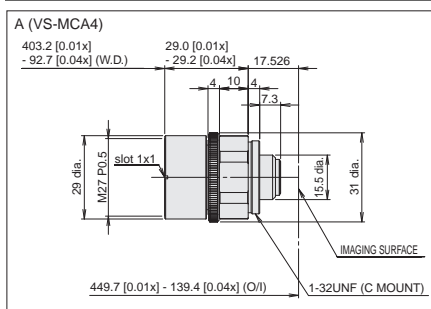

Specifications

Mounting	C mount
Ambient temperature	Operating: -5 to 50°C, Storage: -10 to 60°C (with no icing or condensation)
Ambient humidity	Operating: 35% to 80%, Storage: 35% to 90% (with no condensation)

Optical Chart

Refer to page 95, 96, 99 and 100.

Standard Models
FLV Series

High-brightness Models
FL Series

LED Characteristics

Lenses

High-resolution, Vibrations and Shocks Resistant Lens for C-mount Cameras

VS-MCH1 Series

- Vibrations resistant lens with iris plate system for megapixel C-mount cameras
- Lineup of 6 models with focal lengths ranging from 8 to 50 mm
- Iris plate system to change F number
- Threaded iris plate system to lock the iris in place
- Hexagonal/octagonal lens mount, lock ring, and lens end make tightening easier
- Ideal for use in environments where the point-locked lens is moved under the effects of ambient vibration
- Install in narrow space without a lock screw



Ordering Information

Recommended camera	Model	Dimensions	Focal distance (mm)	Aperture (F No)	Maximum outer diameter (mm)	Total length (mm)	Filter size	WD (mm)	Depth of field * (mm)	Maximum compatible CCD
FH-S□02 FH-S□04 FH-S□21R	3Z4S-LE VS-MC08H1	A	8	1.4	59 dia.	59.0 to 60.2	M55.0 P0.75	302.6	179.0	1 inch
				5.6				55.4	12.0	
				8				27.9	5.7	
				1.4				302.6	735.0	
				5.6				55.4	49.3	
				8				27.9	22.9	
				1.4				302.6	1050.0	
				5.6				55.4	70.4	
				8				27.9	32.7	
	3Z4S-LE VS-MC12H1	B	12	1.4	38 dia.	48.0 to 49.8	M35.5 P0.5	465.4	179.0	1 inch
				5.6				103.8	12.0	
				8				63.6	5.7	
				1.4				465.4	735.0	
				5.6				103.8	49.3	
				8				63.6	22.9	
				1.4				465.4	1050.0	
				5.6				103.8	70.4	
				8				63.6	32.7	
	3Z4S-LE VS-MC16H1	C	16	1.4	36.5 dia.	45.0 to 49.1	M30.5 P0.5	648.1	179.0	1 inch
				5.6				176.6	12.0	
				8				58.1	2.3	
				1.4				648.1	735.0	
				5.6				176.6	49.3	
				8				58.1	9.0	
1.4				648.1				1050.0		
5.6				176.6				70.4		
8				58.1				12.8		
3Z4S-LE VS-MC25H1	D	25	1.4	36.5 dia.	33.5 to 42.4	M30.5 P0.5	1007.9	179.0	1 inch	
			5.6				245.3	12.0		
			8				63.7	1.2		
			1.4				1007.9	735.0		
			5.6				245.3	49.3		
			8				63.7	4.9		
			1.4				1007.9	1050.0		
			5.6				245.3	70.4		
			8				63.7	7.1		
3Z4S-LE VS-MC35H1	E	35	1.4	36.5 dia.	35.0 to 43.8	M30.5 P0.5	1405.7	179.0	1 inch	
			5.6				352.9	12.0		
			8				142.3	2.3		
			1.4				1405.7	735.0		
			5.6				352.9	49.3		
			8				142.3	9.0		
			1.4				1405.7	1050.0		
			5.6				352.9	70.4		
			8				142.3	12.8		

High-resolution, Vibrations and Shocks Resistant Lens for C-mount Cameras VS-MCH1 Series

Recommended camera	Model	Dimensions	Focal distance (mm)	Aperture (F No)	Maximum outer diameter (mm)	Total length (mm)	Filter size	WD (mm)	Depth of field * (mm)	Maximum compatible CCD
FH-S□02 FH-S□04 FH-S□21R	3Z4S-LE VS-MC50H1	F	50	1.4	44 dia.	44.5 to 52.0	M40.5 P0.5	2001.9	179.0	1 inch
								504.1	12.0	
								337.7	5.7	
				5.6				2001.9	735.0	
								504.1	49.3	
								337.7	22.9	
	2001.9	1050.0								
				8				504.1	70.4	
								337.7	32.7	

* Calculated using a permissible circle of confusion diameter of 0.04 mm.

Dimensions

(Unit:mm)

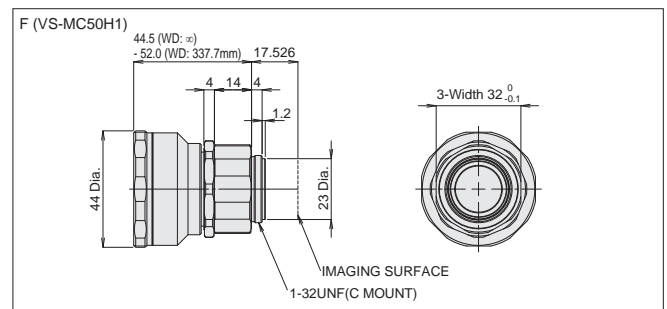
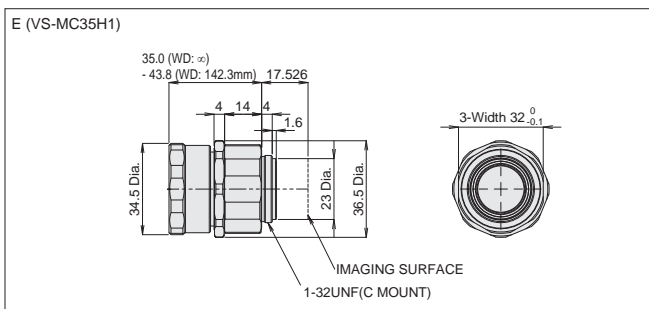
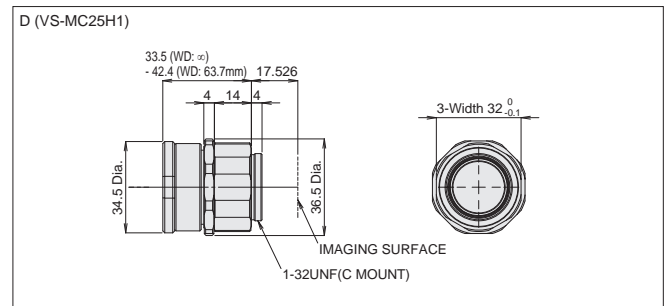
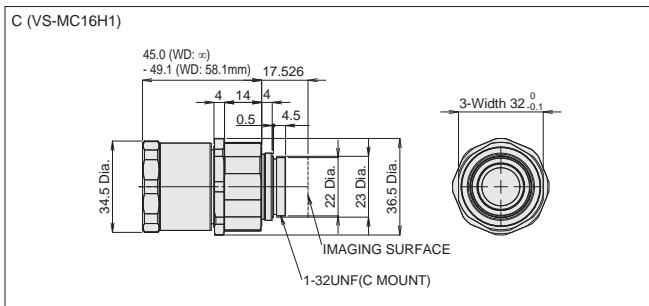
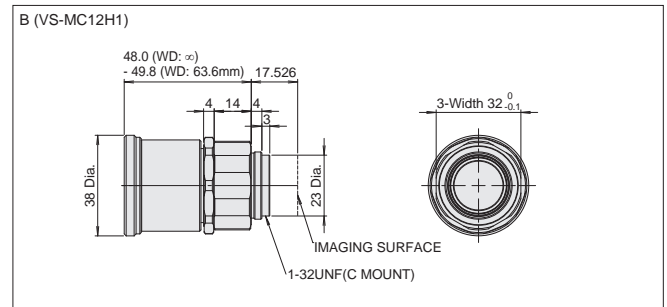
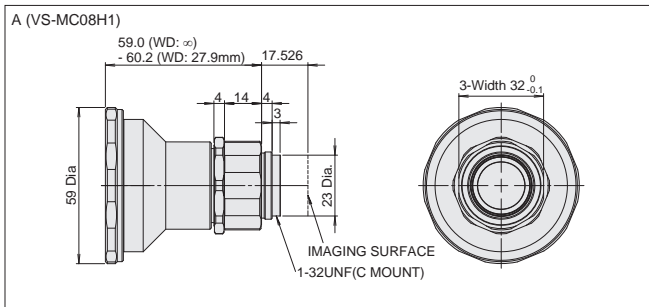

Specifications

Mounting	C mount
Ambient temperature	Operating: -5 to 50°C, Storage: -10 to 60°C (with no icing or condensation)
Ambient humidity	Operating: 0% to 80%, Storage: 0% to 90% (with no condensation)

Optical Chart

Refer to page 95.

Vibrations and Shocks Resistant Lens for M42-mount Cameras

VS-MCL/M42-10 Series

- Vibrations resistant lens for M42-mount cameras.
- Lineup of 18 models: focal lengths from 18 to 100 mm and F-numbers of maximum aperture, 5.6, and 8.0.
- A lock ring locking the surface and the improved design of internal structure increase resistance to vibration in comparison to the previous model. This enables application in environments where the point-locked lens is moved under the effects of ambient vibration.
- Install in narrow space without a lock screw.



Note: Orders for VS-MCL/M42-10 series will be accepted until the end of December 2023.

Ordering Information

Recommended camera	Model	Dimensions	Focal distance (mm)	Aperture (F No)	Maximum outer diameter (mm)	Total length (mm)	Filter size	WD (mm)	Depth of field (mm)	Maximum compatible CCD
FH-S□12	3Z4S-LE VS-MCL18/M42-10	A	18	2.8	52 dia.	91.5 to 96.1	M46.0 P0.75	722.9	367.0	1.8 inches
	168.4							24.6		
	57.9			4.5						
	722.9			735.0						
	168.4			188.0						
	57.9			9.0						
	3Z4S-LE VS-MCL18-FNO56/M42-10	8	52 dia.	91.5 to 96.1	M46.0 P0.75	722.9	1050.0	168.4	269.0	
	57.9							12.8		
	1010.8							367.0		
	3Z4S-LE VS-MCL25/M42-10	B	25	2.6	52 dia.	72.0 to 82.3	M46.0 P0.75	496.6	94.0	1.8 inches
	52.8							1.8		
	1010.8			735.0						
	496.6			188.0						
	52.8			3.9						
	1010.8			1050.0						
	3Z4S-LE VS-MCL25-FNO56/M42-10	8	52 dia.	72.0 to 82.3	M46.0 P0.75	496.6	269.0	52.8	5.6	
	1437.4							367.0		
	346.8							24.6		
3Z4S-LE VS-MCL35/M42-10	C	35	2.8	55 dia.	99.5 to 117.6	M52.0 P0.75	62.2	1.3	1.8 inches	
1437.4							735.0			
346.8			49.3							
62.2			2.7							
1437.4			1050.0							
346.8			70.4							
3Z4S-LE VS-MCL35-FNO56/M42-10	8	55 dia.	99.5 to 117.6	M52.0 P0.75	62.2	3.8	1025.0	97.6		
513.7							24.6			
153.7							2.0			
3Z4S-LE VS-MCL50/M42-10	D	50	2.8	52 dia.	64.0 to 82.0	M46.0 P0.75	1025.0	188.0	1.8 inches	
513.7							49.3			
153.7			3.9							
1025.0			269.0							
513.7			70.4							
153.7			5.6							
3Z4S-LE VS-MCL50-FNO56/M42-10	8	52 dia.	64.0 to 82.0	M46.0 P0.75	1724.8	134.0	452.5	9.6		
285.0							3.5			
1724.8							188.0			
3Z4S-LE VS-MCL85/M42-10	E	85	4	52 dia.	105.0 to 130.2	M46.0 P0.75	452.5	13.4	1.8 inches	
285.0							4.9			
1724.8			269.0							
452.5			19.2							
285.0			7.1							
1724.8			269.0							

Non-telecentric Macro Lens for C-mount Cameras

VS-MC Series

- Lineup of 4 models with magnifications ranging from 0.1x to 1.0x and WD ranging from 82.4 to 325.5 mm.
- 16-mm-dia. simple mechanism with high resistance to vibration.



Ordering Information

Recommend camera	Model	Dimensions	Magnification	Effective FNO	O/I (mm)	WD (mm)	Depth of field *1 (mm)	Resolution *2 (μm)	TV distortion
FZ-S□ FZ-SH□ FH-S□ FH-S□X FZ-S□2M FZ-S□5M3 FH-S□05R FH-S□X05 FHV7X-□	3Z4S-LE VS-MC01-330	A	0.1x	4.43	364.5	325.5	35.4	30.5	0.01% max.
	3Z4S-LE VS-MC03-180	B	0.3x	5.29	248.5	184.8	4.7	11.6	0.00% max.
	3Z4S-LE VS-MC05-130	C	0.5x	6.10	198.8	126.3	2.0	8.2	0.00% max.
	3Z4S-LE VS-MC1-80	D	1.0x	8.14	176.8	82.4	0.7	5.5	0.00% max.

*1. Calculated using a permissible circle of confusion diameter of 0.04 mm.

*2. Calculated using a wavelength of 550 nm.

Camera and Field of View Table

Camera	Size of image element (inch)	Imaging area HxV (mm)	Field of view HxV (mm)			
			0.1 × (VS-MC01-330)	0.3 × (VS-MC03-180)	0.5 × (VS-MC05-130)	1.0 × (VS-MC1-80)
FH-S□/FZ-S□/VS-SH□	1/3" equivalent	4.8 × 3.6	48.0 × 36.0	16.0 × 12.0	9.6 × 7.2	4.8 × 3.6
FH-S□X	1/2.9" equivalent	5.0 × 3.8	50.0 × 38.0	16.7 × 12.7	10.0 × 7.6	5.0 × 3.8
FH-S□05R	1/2.5" equivalent	5.7 × 4.3	57.0 × 43.0	19.0 × 14.3	11.4 × 8.6	5.7 × 4.3
FZ-S□2M	1/1.8" equivalent	7.0 × 5.3	70.0 × 53.0	23.3 × 17.7	14.0 × 10.6	7.0 × 5.3
FH-S□X05/FZ-S□5M3	2/3" equivalent	8.4 × 7.1	84.0 × 71.0	28.0 × 23.7	16.8 × 14.2	8.4 × 7.1
FHV7X-□004-C	1/2.9" equivalent	5.0×3.8	50.0×38.0	16.7×12.7	10.0×7.6	5.0×3.8
FHV7X-□016-C	1/2.9" equivalent	5.0×3.8	50.0×38.0	16.7×12.7	10.0×7.6	5.0×3.8
FHV7X-□032-C	1/1.8" equivalent	7.1×5.3	71.0×53.0	23.7×17.7	14.2×10.6	7.1×5.3
FHV7X-□050-C	2/3" equivalent	8.5×7.1	85.0×71.0	28.3×23.7	17.0×14.2	8.5×7.1
FHV7X-□063R-C	1/1.8" equivalent	7.4×5.0	74.0×50.0	24.7×16.7	14.8×10.0	7.4×5.0
FHV7X-□120R-C	1/1.7" equivalent	7.4×5.6	74.0×56.0	24.7×18.7	14.8×11.2	7.4×5.6

Note: The field of view is a calculated value and not a guaranteed value.

Dimensions

(Unit:mm)

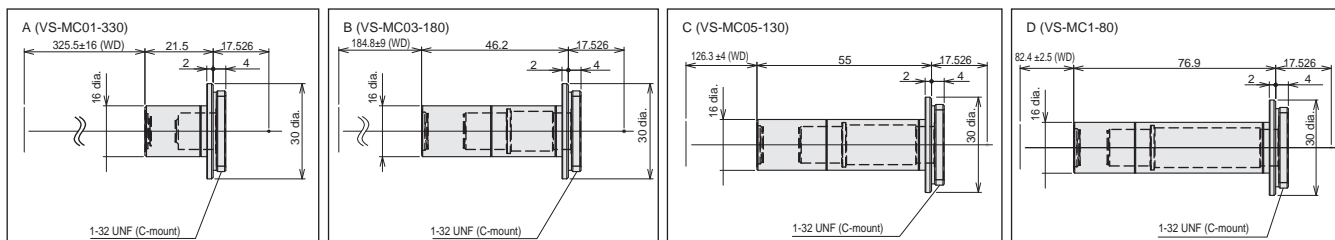

Specifications

Mounting	C mount
Ambient temperature	Operating: 0 to 50°C, Storage: -10 to 60°C (with no icing or condensation)
Ambient humidity	Operating: 35% to 80%, Storage: 35% to 90% (with no condensation)

Lens Option

Polarizing Filter SV-PL Series

- Prevents diffused reflection.
- Available for lenses for C-mount cameras.



Ordering Information

Item	Size	Anti-rotation mechanism: Provided		Anti-rotation mechanism: Not provided	
		Model	Weight (g)	Model	Weight (g)
Polarizing Filter	M22.5 P0.5	3Z4S-LE SV-PL225-SS	5	—	—
	M25.5 P0.5	3Z4S-LE SV-PL255-SS	6	3Z4S-LE SV-PL255	5.5
	M27.0 P0.5	3Z4S-LE SV-PL270-SS	6.5	3Z4S-LE SV-PL270	6
	M30.5 P0.5	3Z4S-LE SV-PL305-SS	8	3Z4S-LE SV-PL305	7.5
	M34.0 P0.5	3Z4S-LE SV-PL340-SS	10	3Z4S-LE SV-PL340	9.5
	M35.5 P0.5	3Z4S-LE SV-PL355-SS	10	3Z4S-LE SV-PL355	9.5
	M37.5 P0.5	3Z4S-LE SV-PL375-SS	12	3Z4S-LE SV-PL375	11.5
	M40.5 P0.5	3Z4S-LE SV-PL405-SS	12.5	3Z4S-LE SV-PL405	12
	M52.0 P0.75	3Z4S-LE SV-PL520-SS	19	3Z4S-LE SV-PL520	18.5
	M55.0 P0.75	3Z4S-LE SV-PL550-SS	21	3Z4S-LE SV-PL550	20.5
M62.0 P0.75	3Z4S-LE SV-PL620-SS	28.5	3Z4S-LE SV-PL620	27.5	

Specifications

Ambient temperature	Operating: 0 to 50°C, Storage: -10 to 60°C (with no icing or condensation)
Ambient humidity	Operating: 35% to 80%, Storage: 35% to 90% (with no condensation)

Protection Cover Filter SV-GA Series

- Used to protect lens surface from dust.
- Available for lenses for C-mount cameras.

Ordering Information

Item	Model	Size	Weight (g)
Protection Cover Filter	3Z4S-LE SV-GA225	M22.5 P0.5	4
	3Z4S-LE SV-GA255	M25.5 P0.5	4.5
	3Z4S-LE SV-GA270	M27.0 P0.5	5.5
	3Z4S-LE SV-GA305	M30.5 P0.5	6.5
	3Z4S-LE SV-GA340	M34.0 P0.5	8
	3Z4S-LE SV-GA355	M35.5 P0.5	8.5
	3Z4S-LE SV-GA375	M37.5 P0.5	9
	3Z4S-LE SV-GA405	M40.5 P0.5	10.5
	3Z4S-LE SV-GA520	M52.0 P0.75	15
	3Z4S-LE SV-GA550	M55.0 P0.75	16
3Z4S-LE SV-GA620	M62.0 P0.75	25	



Specifications

Ambient temperature	Operating: 0 to 50°C, Storage: -10 to 60°C (with no icing or condensation)
Ambient humidity	Operating: 35% to 80%, Storage: 35% to 90% (with no condensation)

Lens Option

Extension Tubes

Ordering Information

Lenses	Model	Contents
For C-mount Lens	3Z4S-LE SV-EXR	Set of 7 tubes *1,*2 (40 mm, 20 mm, 10 mm, 5 mm, 2mm, 1 mm, 0.5 mm) Maximum outer diameter: 30 mm dia.
For M42-mount Cameras	3Z4S-LE VS-EXR/M42	Set of 5 tubes *1 (20 mm, 10 mm, 8 mm, 2 mm, and 1 mm) Maximum outer diameter: 47.5 mm dia.
For Small Digital CCD Cameras	FZ-LESR	Set of 3 tubes (15 mm, 10 mm, 5 mm) Maximum outer diameter: 12 mm dia.



- *1. Do not use the 0.5-mm, 1.0-mm, and 2.0-mm Extension Tubes attached to each other. Since these Extension Tubes are placed over the threaded section of the Lens or other Extension Tube, the connection may loosen when more than one 0.5-mm, 1.0-mm or 2.0-mm Extension Tube are used together.
Reinforcement is required to protect against vibration when Extension Tubes exceeding 30 mm are used. When using the Extension Tube, check it on the actual device before using it.
- *2. These Extension Tubes are also available individually. Order using the following model number, replacing the box with the desired length: 3Z4SLE SV-EXR□. (0.5, 1, 2, 5, 10, 15, 20, 25, 30, 40, 50 mm)

Rear Converter Lens

Ordering Information

Model
3Z4S-LE SV-1.5X *1
3Z4S-LE SV-2.0X *2

Configuration

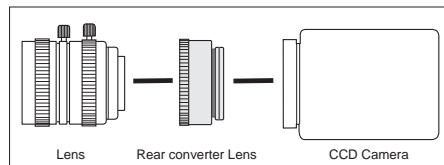

- *1. In the following lenses, it is necessary to use it together with the extension tubes of 5 mm or more.
SV-0614H, SV-0814H, SV-1214H, SV-2514H, SV-0614V, SV-0813V
- *2. In the following lenses, it is necessary to use it together with the extension tubes of 5 mm or more.
SV-0614H, SV-0814H, SV-1214H, SV-2514H, SV-0813V

M42 - F Mount Conversion Adapter

Ordering Information

Cameras	Lenses	Model
FH-S□12 (M42 mount)	F mount	FH-ADF/M42-10

Optical Chart

Optical Chart

Meaning of Optical Chart

The X axis of the optical chart shows the field of vision (mm) (*1), and the Y axis of the optical chart shows the camera installation distance (mm) (*2).

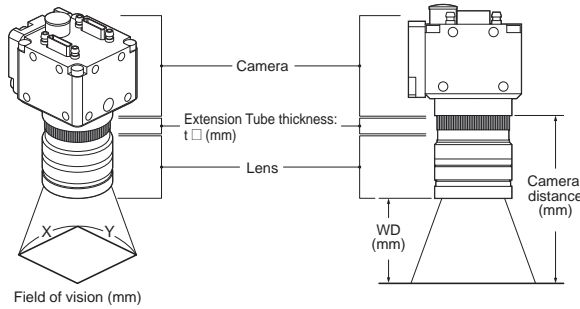

To select a lens, use the WEB Selector.
https://www.fa.omron.co.jp/lens_en

*1. The lengths of the fields of vision given in the optical charts are the lengths of the Y axis.

*2. The vertical axis represents WD for small cameras.

Vision system FH/FZ Series

Standard Lenses

High-speed Digital CMOS Camera FH-S□,
 High-speed Digital CCD Camera FZ-SH□,
 Digital CCD Camera FZ-S□
 0.3 million-pixel
 (Using 3Z4S-LE SV-V Series)

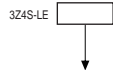

SV-10035V	SV-3518V	SV-1214V	SV-04514V
SV-7527V	SV-2514V	SV-0813V	SV-03514V
SV-5018V	SV-1614V	SV-0614V	

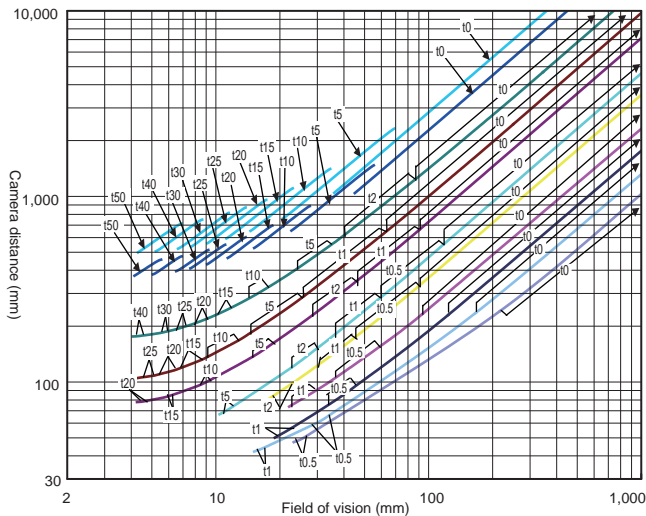

High-speed Digital CMOS Camera
 FH-S□X
 0.4 million-pixel
 (Using 3Z4S-LE SV-V Series)



SV-10035V	SV-1214V
SV-7527V	SV-0813V
SV-5018V	SV-0614V
SV-3518V	SV-04514V
SV-2514V	SV-03514V
SV-1614V	

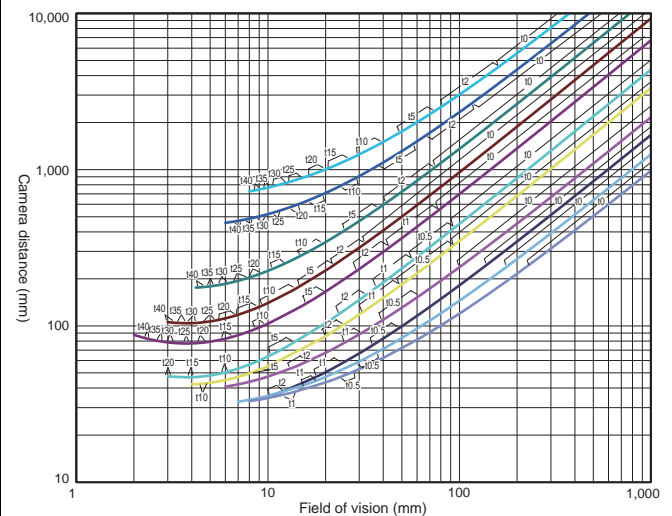

Optical Chart

Digital CCD Camera FZ-S□2M 2 million-pixel (Using 3Z4S-LE SV-H Series)

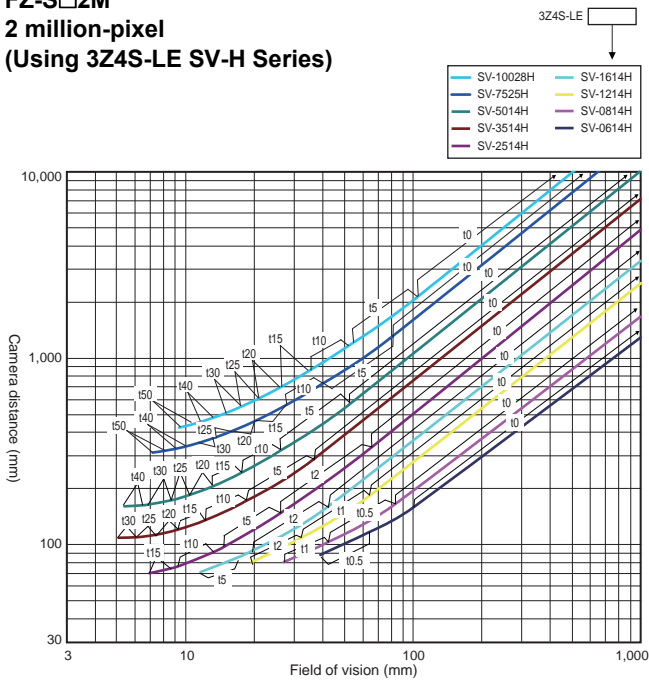

Digital CMOS Camera FZ-S□5M3, High-speed Digital CMOS Camera FH-S□X05 5 million-pixel (Using 3Z4S-LE SV-H Series)

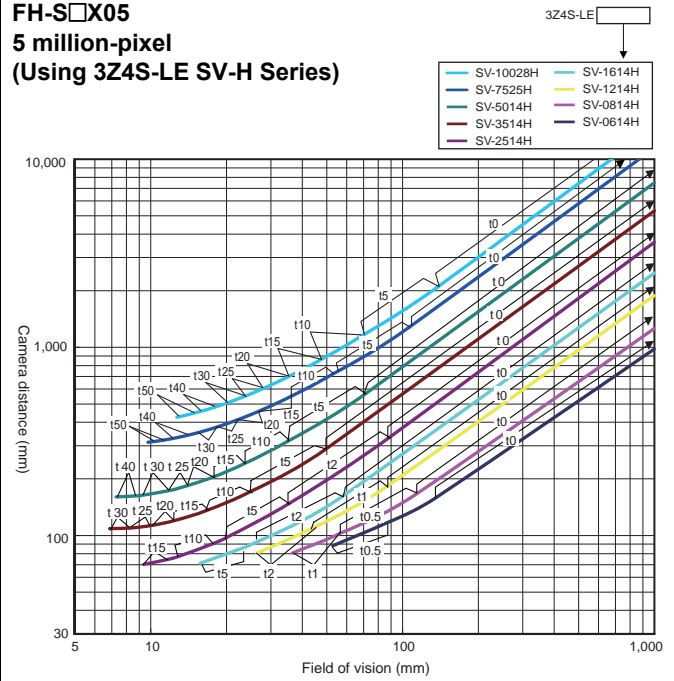

Digital CMOS Camera FH-S□05R 5 million-pixel (Using 3Z4S-LE SV-H Series)

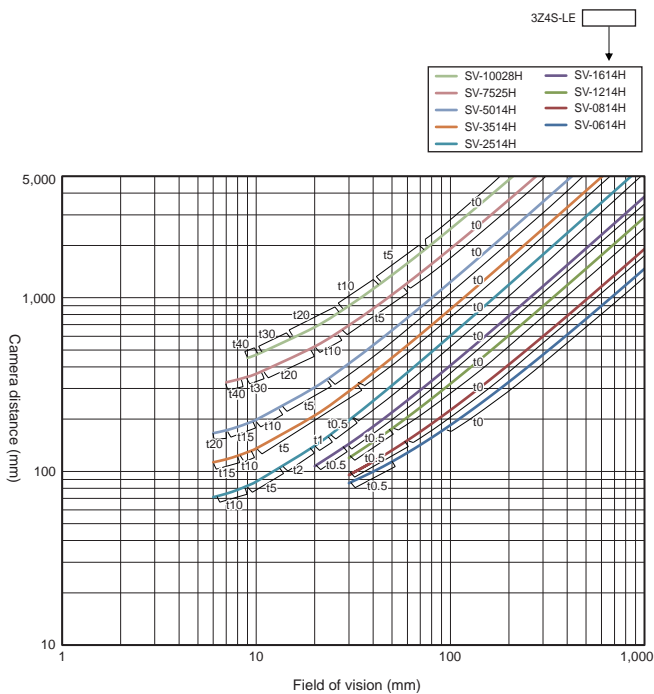

High-speed Digital CMOS Camera FH-S□X01 1.6 million-pixel (Using 3Z4S-LE SV-H Series)

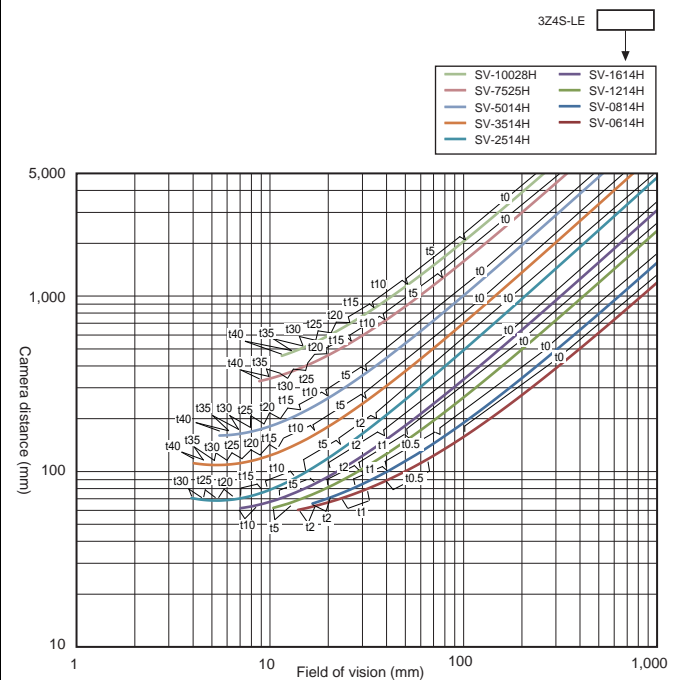

**High-speed Digital CMOS Camera
FH-S□X03
3.2 million-pixel
(Using 3Z4S-LE SV-H Series)**

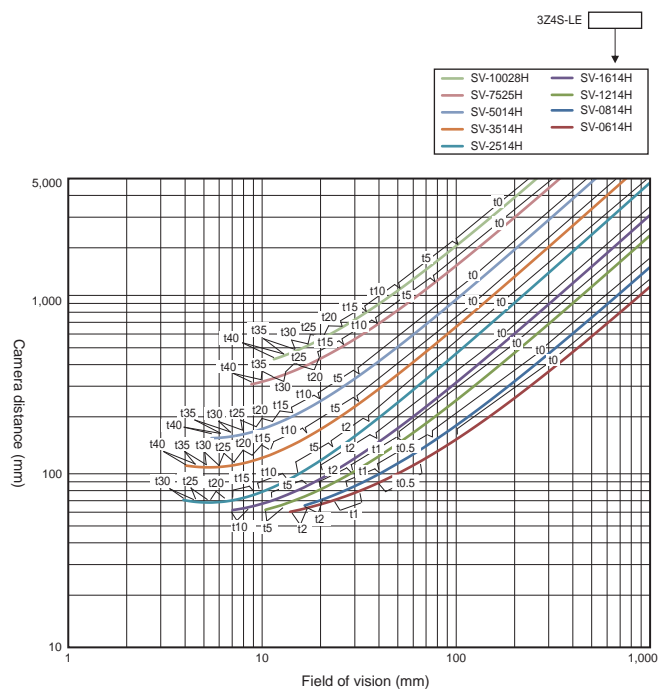

**High-speed Digital CMOS Camera
FH-S□02
2 million-pixel
(Using 3Z4S-LE SV-H/VS-H1 Series)**

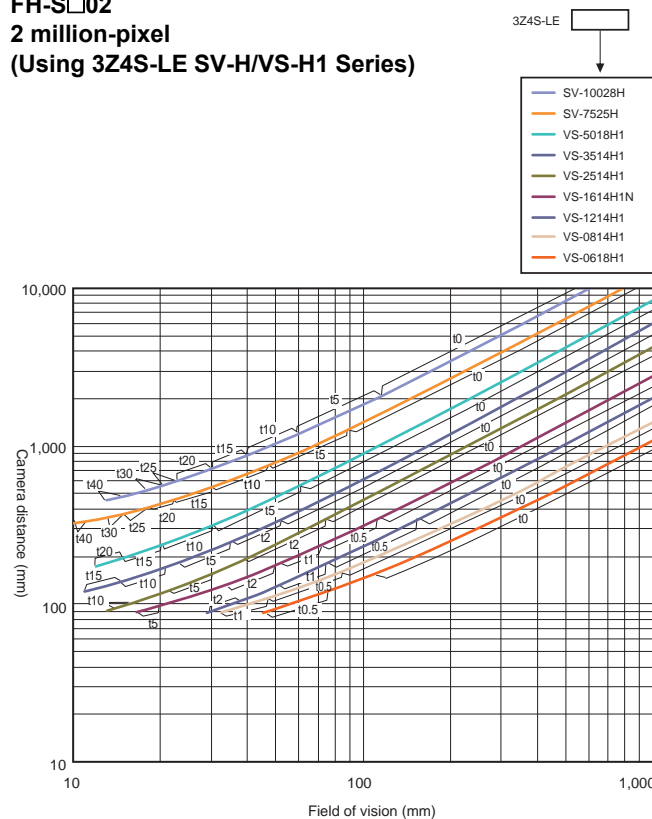

**High-speed Digital CMOS Camera
FH-S□04
4 million-pixel
(Using 3Z4S-LE SV-H/VS-H1 Series)**

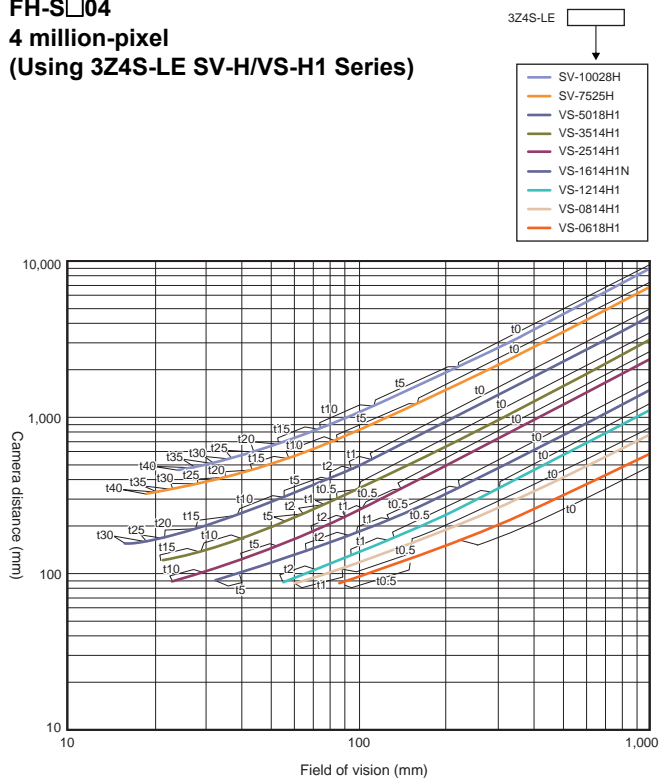

**High-speed Digital CMOS Camera
FH-S□12
12 million-pixel
(Using 3Z4S-LE VS-L/M42-10 Series)**

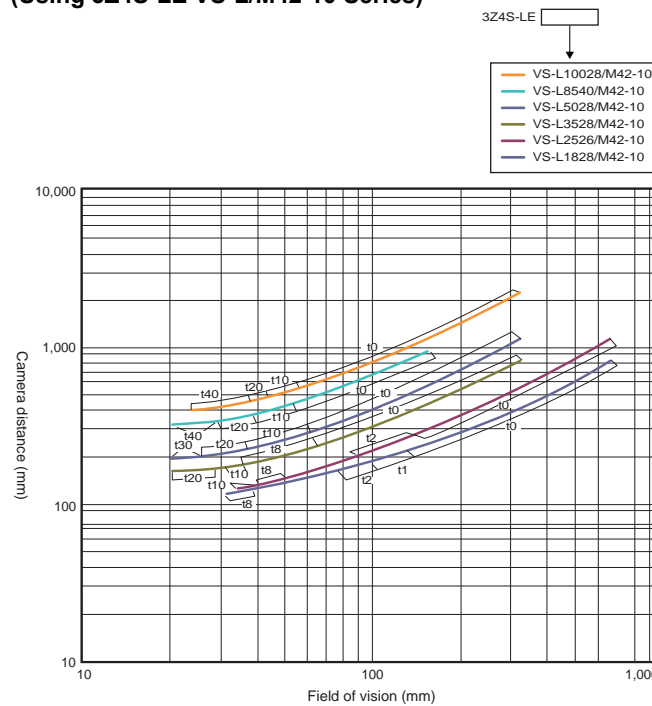

Standard Models
FLV Series

High-brightness Models
FL Series

LED Characteristics

Lenses

High-speed Digital CMOS Camera FH-S□X12 12 million-pixel (Using 3Z4S-LE VS-HVA Series)

Note: The 3Z4S-LE VS-HVA Series cannot be used with an extension tube.

3Z4S-LE 

- VS-HVA1226
- VS-HVA1626
- VS-HVA2524
- VS-HVA3522
- VS-HVA5024

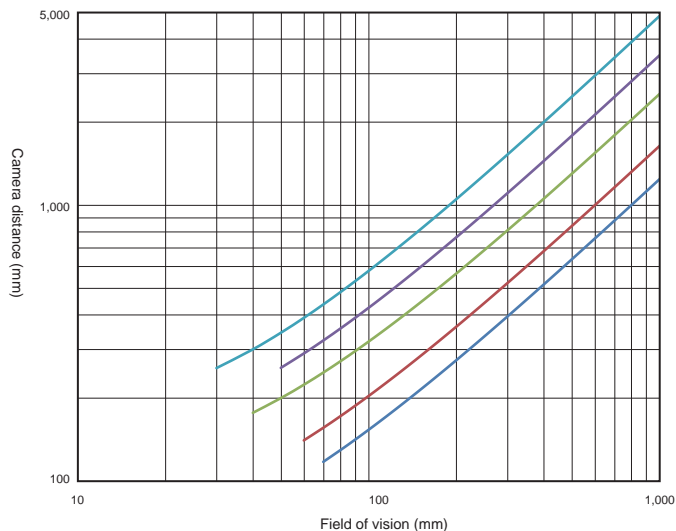

Digital CMOS Camera FH-S□21R 20.4 million-pixel (Using 3Z4S-LE VS-HVA Series)

Note: The 3Z4S-LE VS-HVA Series cannot be used with an extension tube.

3Z4S-LE 

- VS-HVA1226
- VS-HVA1626
- VS-HVA2524
- VS-HVA3522
- VS-HVA5024

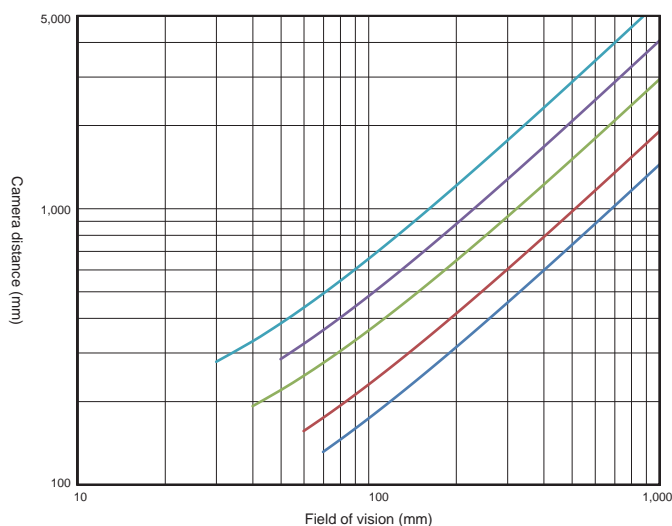

High-speed Digital CMOS Camera FH-S□X12 12 million-pixel (Using 3Z4S-LE VS-LLD Series)

Note: The 3Z4S-LE VS-LDD Series cannot be used with an extension tube.

3Z4S-LE 

- VS-LLD50
- VS-LLD35
- VS-LLD25
- VS-LLD18
- VS-LLD12.5

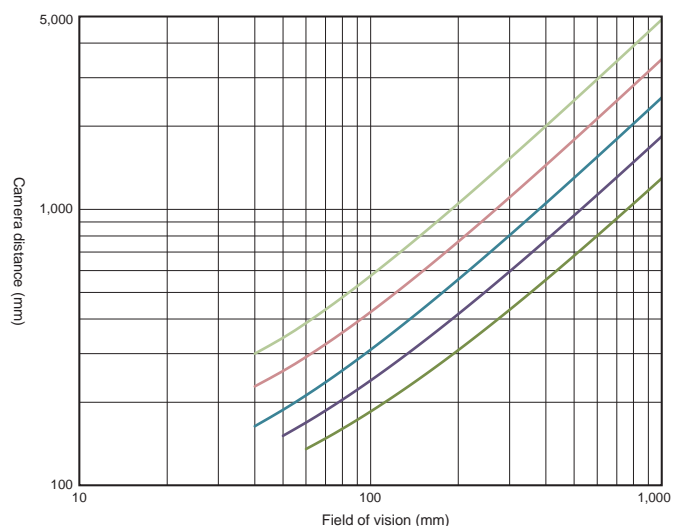

Digital CMOS Camera FH-S□21R 20.4 million-pixel (Using 3Z4S-LE VS-LLD Series)

Note: The 3Z4S-LE VS-LDD Series cannot be used with an extension tube.

3Z4S-LE 

- VS-LLD50
- VS-LLD35
- VS-LLD25
- VS-LLD18
- VS-LLD12.5

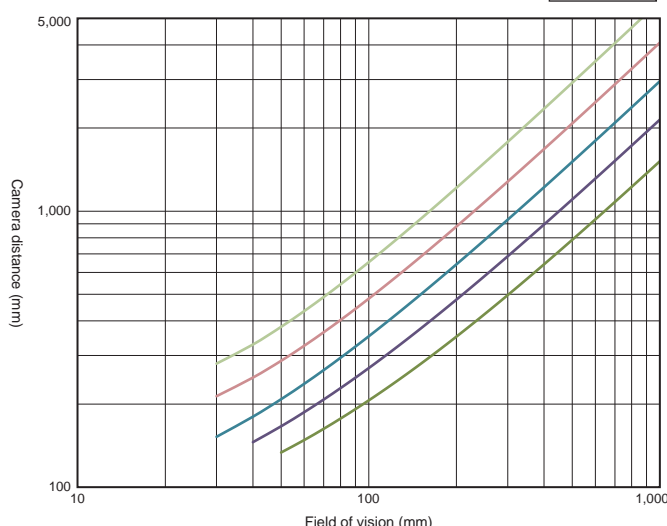

Small Digital CCD Cameras

**FZ-SF□,
FZ-SP□
0.3 million-pixel
(Using FZ-LES Series)**

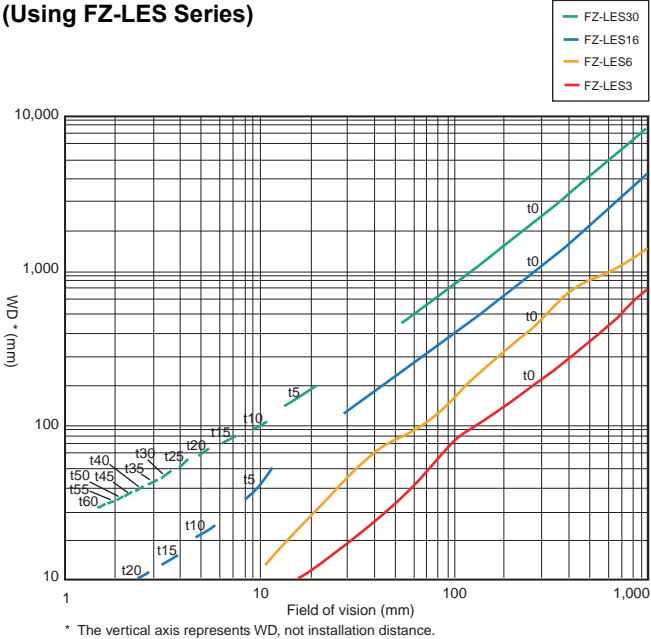

Vibrations and Shocks Resistant Lenses

**High-speed Digital CMOS Camera
FH-S□,
High-speed Digital CCD Camera
FZ-SH□,
Digital CCD Camera
FZ-S□
0.3 million-pixel
(Using 3Z4S-LE VS-MCA Series)**

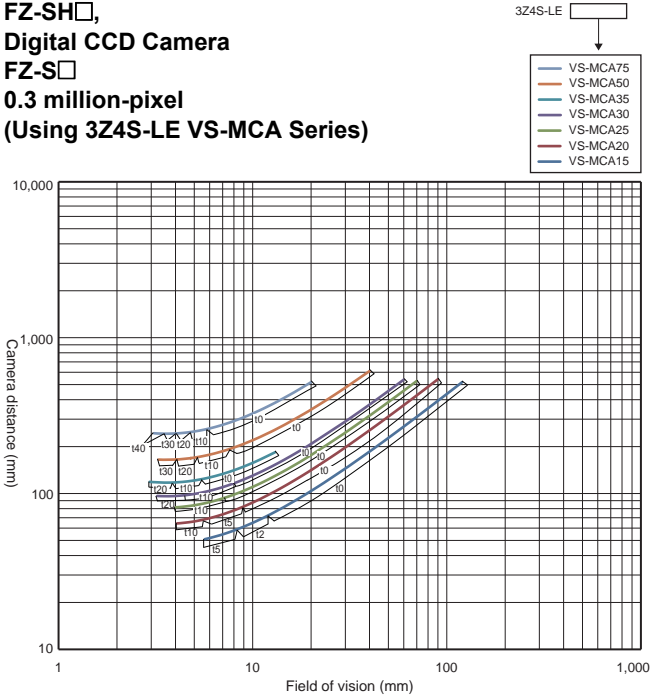

**High-speed Digital CMOS Camera
FH-S□X
0.4 million-pixel
High-speed Digital CMOS Camera
FH-S□X01
1.6 million-pixel
(Using 3Z4S-LE VS-MCA Series)**

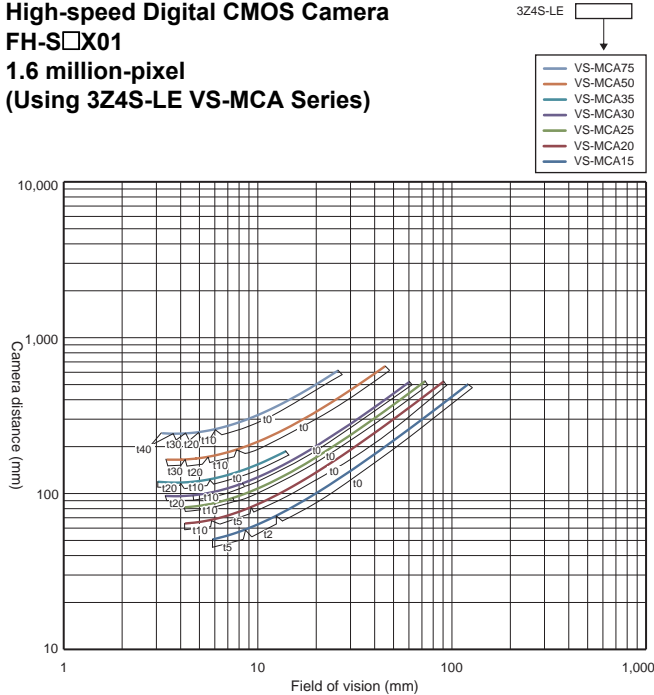

Optical Chart

Standard Models
FLV Series

High-brightness Models
FL Series

LED Characteristics

Lenses

Digital CCD Camera FZ-S□2M 2 million-pixel (Using 3Z4S-LE VS-MCA Series)

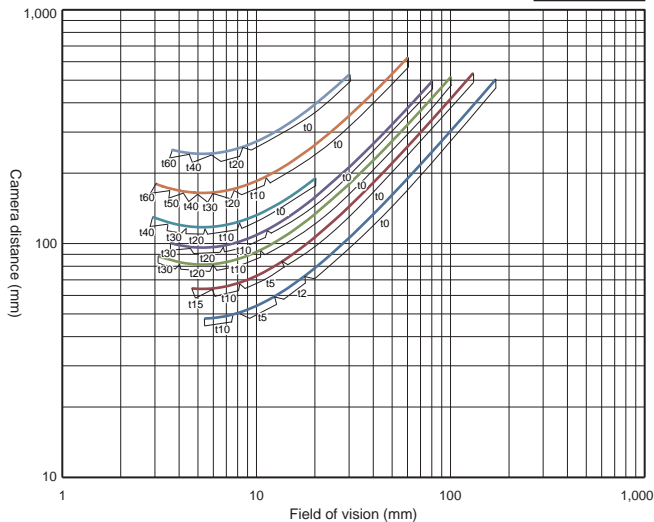
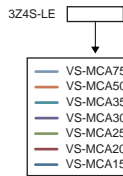

High-speed Digital CMOS Camera FH-S□X03 3.2 million-pixel (Using 3Z4S-LE VS-MCA Series)

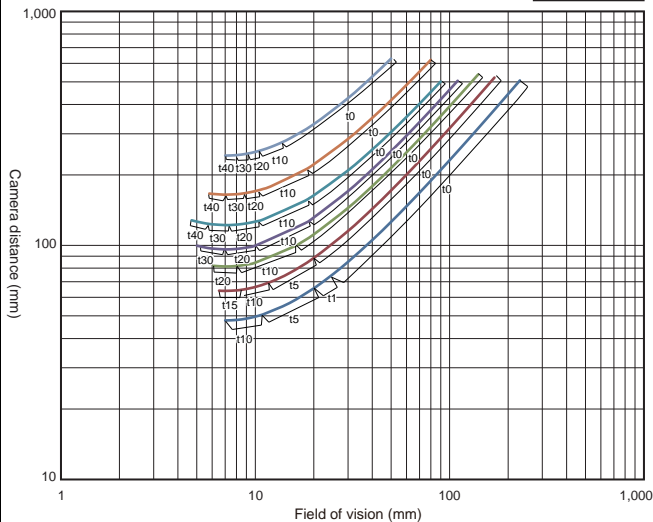
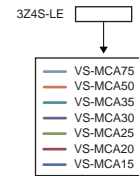

Digital CMOS Camera FZ-S□5M3, High-speed Digital CMOS Camera FH-S□X05 5 million-pixel (Using 3Z4S-LE VS-MCA Series)

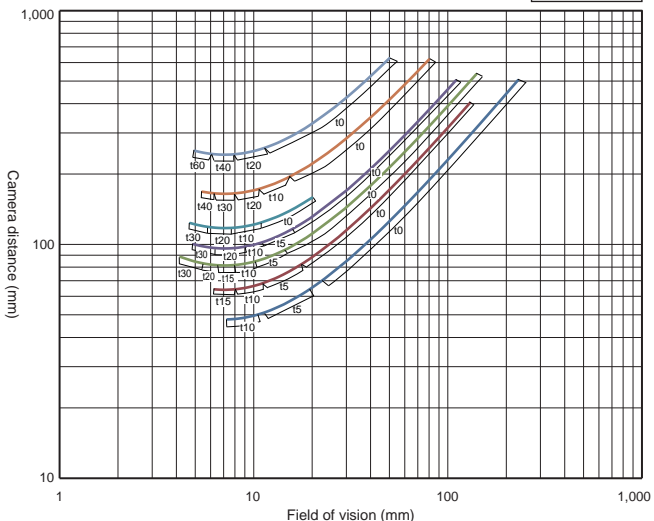

Digital CMOS Camera FH-S□05R 5 million-pixel (Using 3Z4S-LE VS-MCA Series)

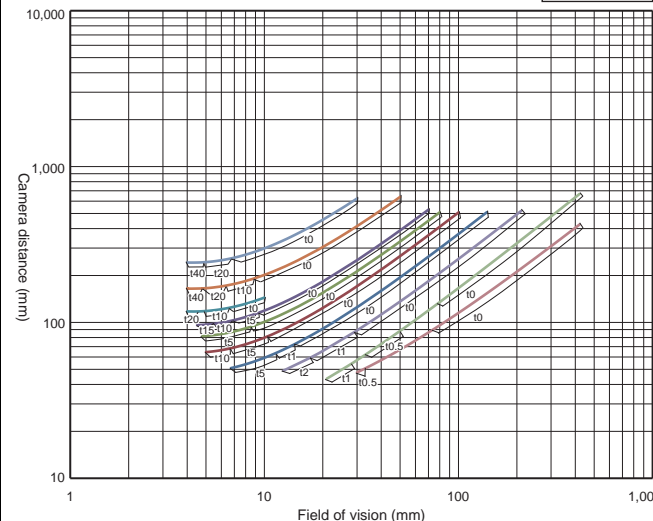
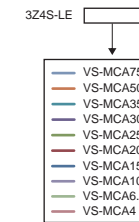

High-speed Digital CMOS Camera
FH-S□02
 2 million-pixel
 (Using 3Z4S-LE VS-MCH1 Series)

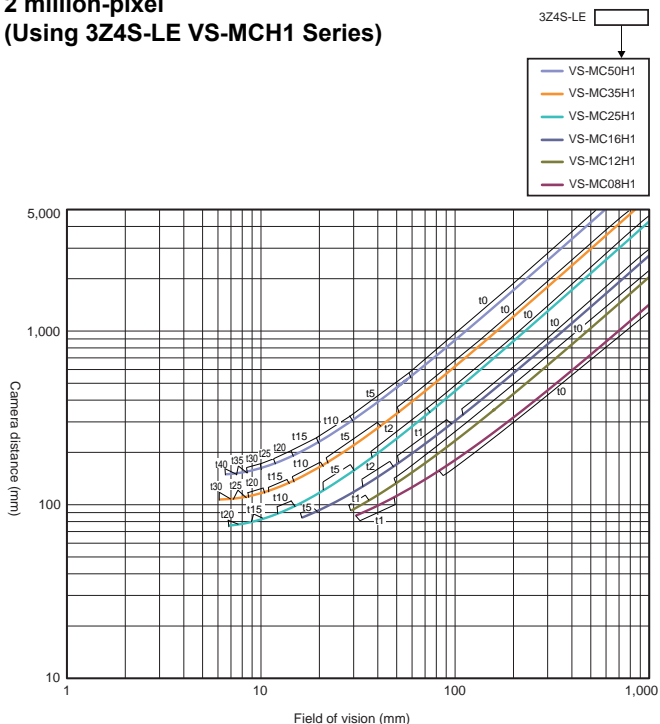

High-speed Digital CMOS Camera
FH-S□04
 4 million-pixel
 (Using 3Z4S-LE VS-MCH1 Series)

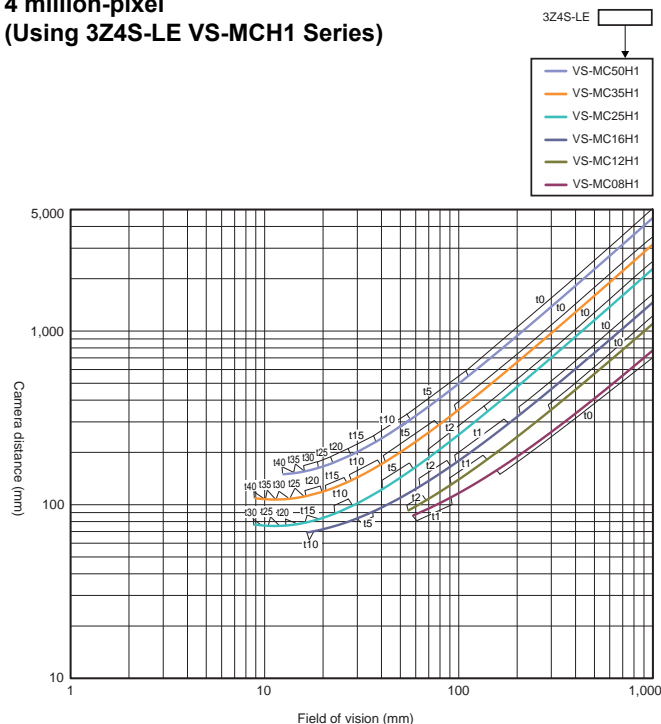

Digital CMOS Camera
FH-S□21R
 20.4 million-pixel
 (Using 3Z4S-LE VS-MCH1 Series)

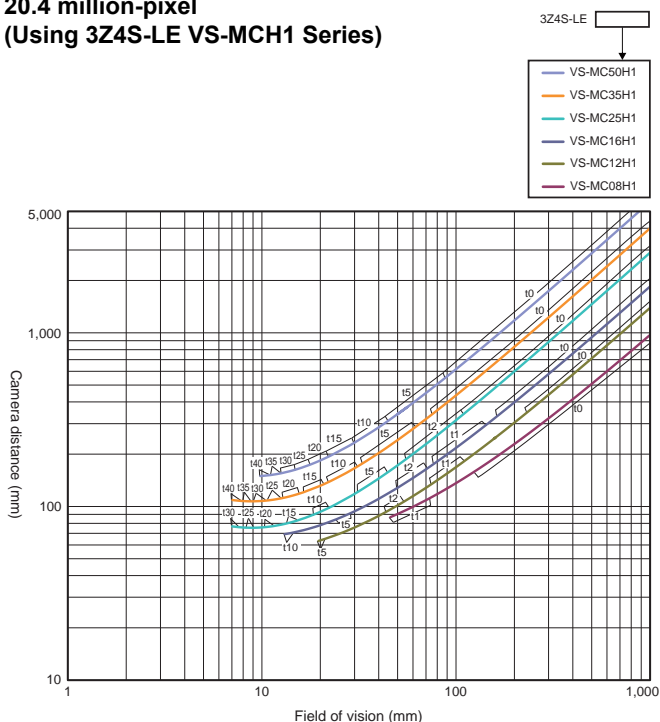

High-speed Digital CMOS Camera
FH-S□12
 12 million-pixel
 (Using 3Z4S-LE VS-MCL/M42-10 Series)

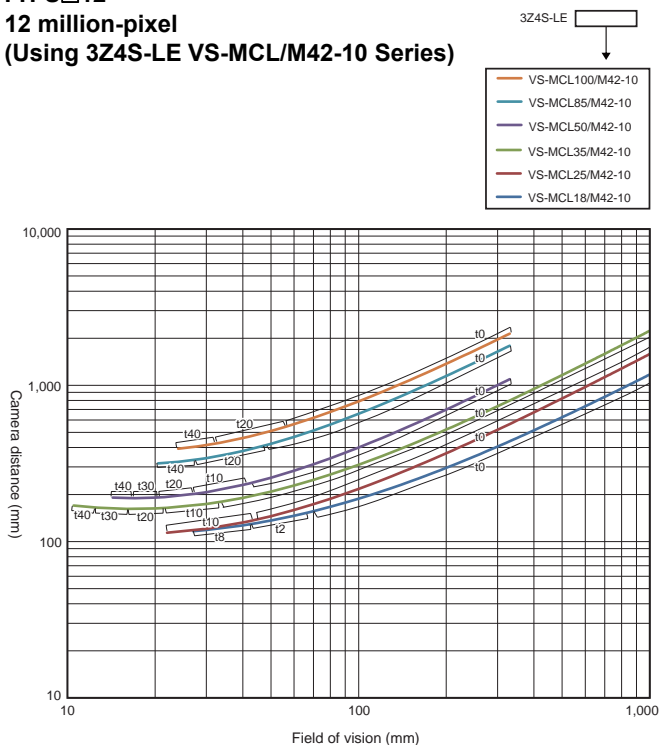

Standard Models
 FLV Series

High-brightness Models
 FL Series

LED Characteristics

Lenses

Smart Camera FHV7 Series

Standard Lenses

0.4 million pixels

1.6 million pixels

Smart Cameras:

FHV7X-□004, FHV7X-□016

(for 3Z4S-LE SV-V series)

3Z4S-LE

- | | |
|-----------|-----------|
| SV-1003SV | SV-1214V |
| SV-7527V | SV-0813V |
| SV-5018V | SV-0614V |
| SV-3518V | SV-04514V |
| SV-2514V | SV-03514V |
| SV-1614V | |

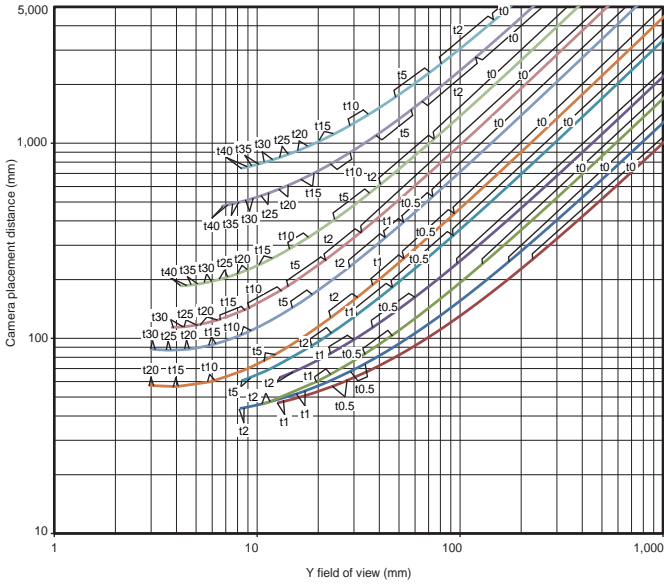

0.4 million pixels

1.6 million pixels

Smart Cameras:

FHV7X-□004, FHV7X-□016

(for 3Z4S-LE SV-H series)

3Z4S-LE

- | | |
|-----------|----------|
| SV-10028H | SV-1614H |
| SV-7525H | SV-1214H |
| SV-5014H | SV-0814H |
| SV-3514H | SV-0614H |
| SV-2514H | |

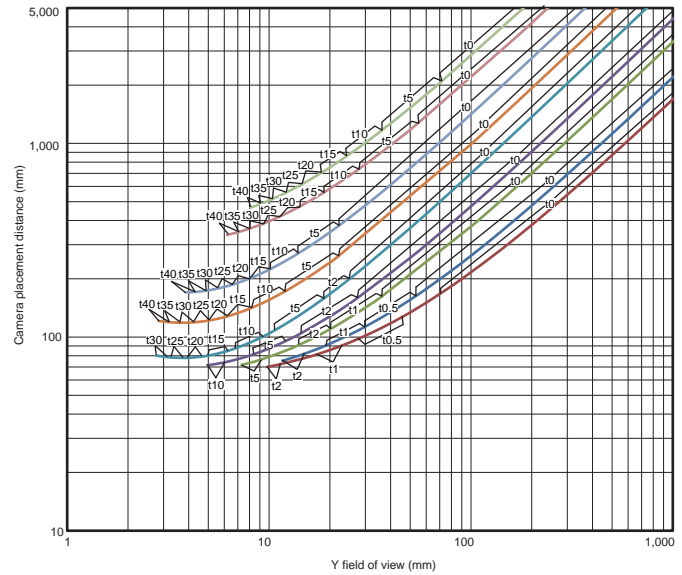

3.2 million pixels

Smart Cameras: FHV7X-□032

(for 3Z4S-LE SV-H series)

3Z4S-LE

- | | |
|-----------|----------|
| SV-10028H | SV-1614H |
| SV-7525H | SV-1214H |
| SV-5014H | SV-0814H |
| SV-3514H | SV-0614H |
| SV-2514H | |

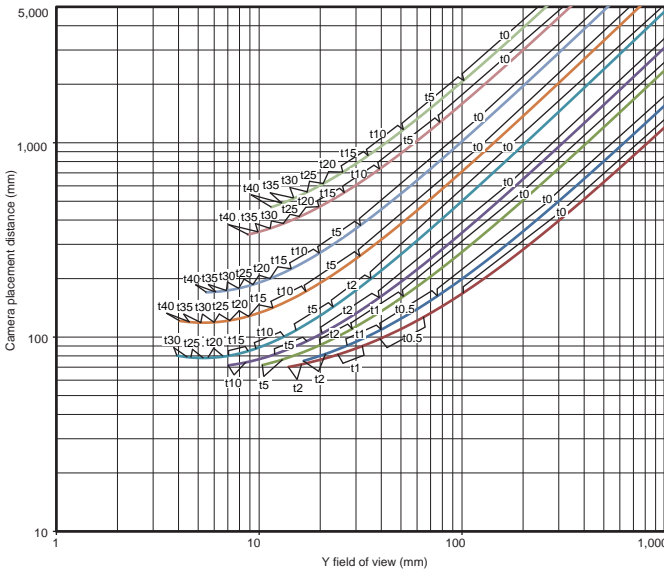

5 million pixels

Smart Cameras: FHV7X-□050

(for 3Z4S-LE SV-H series)

3Z4S-LE

- | | |
|-----------|----------|
| SV-10028H | SV-1614H |
| SV-7525H | SV-1214H |
| SV-5014H | SV-0814H |
| SV-3514H | SV-0614H |
| SV-2514H | |

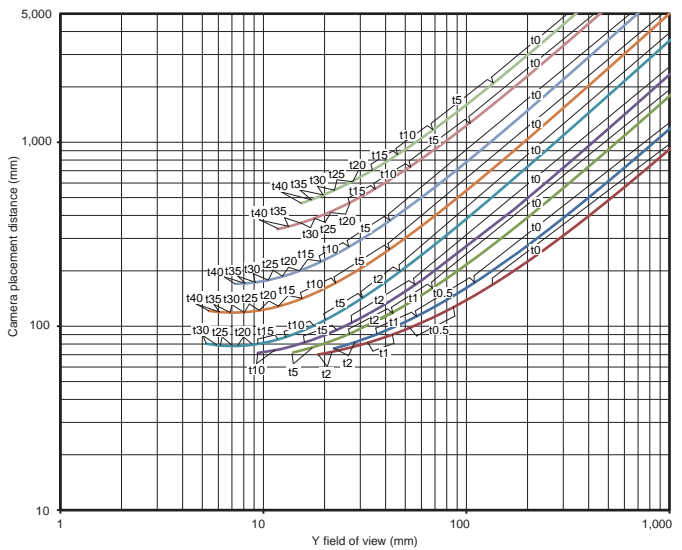

6.3 million pixels
Smart Cameras: FHV7X-□063R
(for 3Z4S-LE SV-H series)



- SV-10028H
- SV-7525H
- SV-5014H
- SV-3514H
- SV-2514H
- SV-1614H
- SV-1214H
- SV-0814H
- SV-0614H

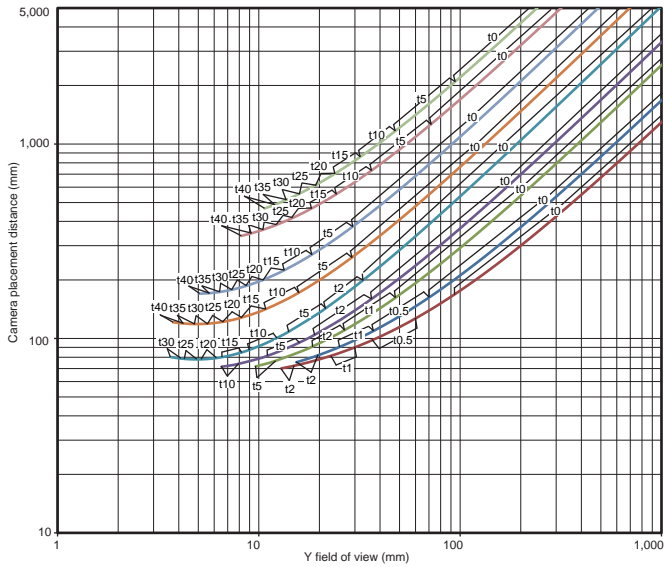

12 million pixels
Smart Cameras: FHV7X-□120R
(for 3Z4S-LE SV-H series)



- SV-10028H
- SV-7525H
- SV-5014H
- SV-3514H
- SV-2514H
- SV-1614H
- SV-1214H
- SV-0814H
- SV-0614H

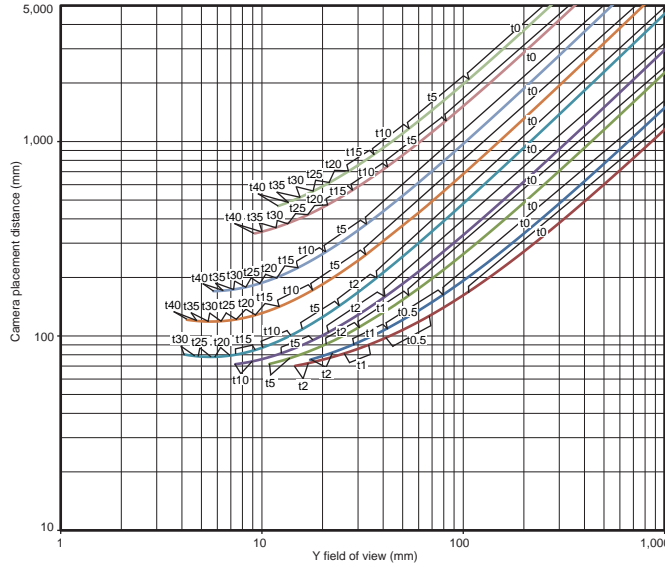

Vibrations and Shocks Resistant Lenses

0.4 million pixels
1.6 million pixels
Smart Cameras: FHV7X-□004, FHV7X-□016
(for 3Z4S-LE VS-MCA series)



- VS-MCA75
- VS-MCA50
- VS-MCA35
- VS-MCA30
- VS-MCA25
- VS-MCA20
- VS-MCA15
- VS-MCA10
- VS-MCA6.5
- VS-MCA4

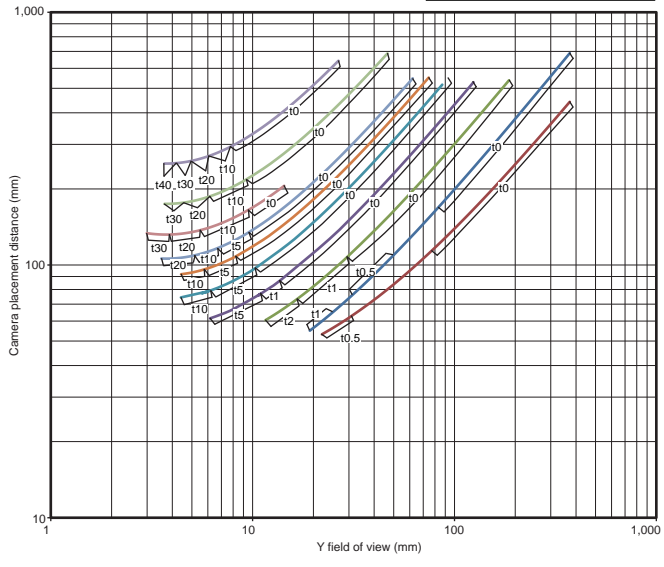

3.2 million pixels
Smart Cameras: FHV7X-□032
(for 3Z4S-LE VS-MCA series)



- VS-MCA75
- VS-MCA50
- VS-MCA35
- VS-MCA30
- VS-MCA25
- VS-MCA20
- VS-MCA15

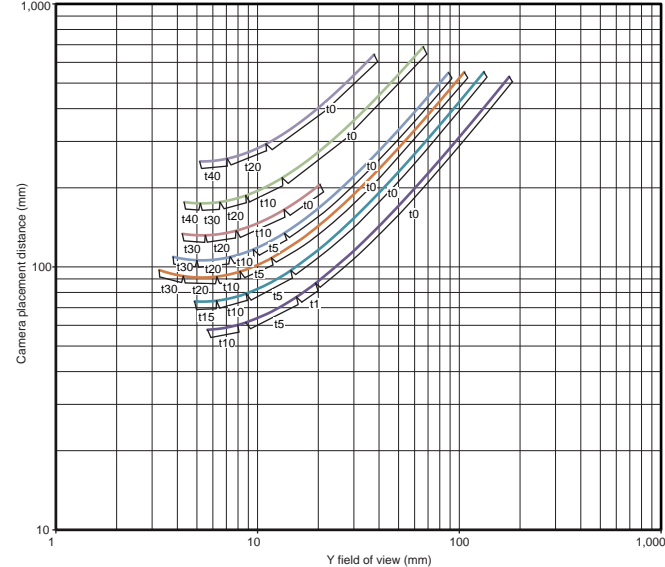

Optical Chart

Standard Models
FLV Series

High-brightness Models
FL Series

LED Characteristics

Lenses

5 million pixels
Smart Cameras: FHV7X-□050
(for 3Z4S-LE VS-MCA series)

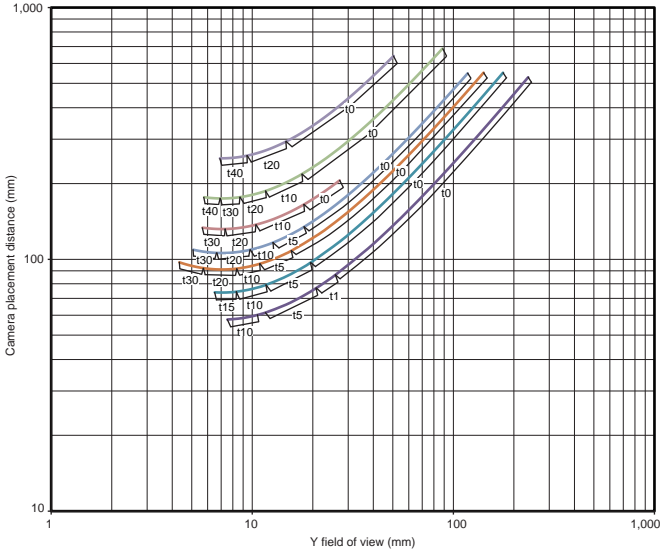
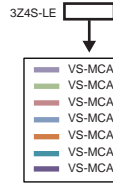

6.3 million pixels
Smart Cameras: FHV7X-□063R
(for 3Z4S-LE VS-MCA series)

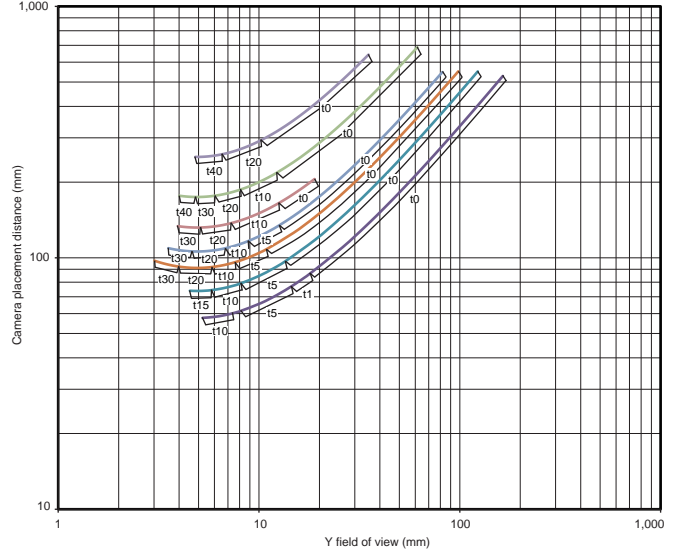
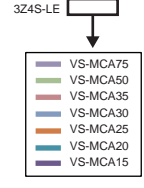

12 million pixels
Smart Cameras: FHV7X-□120R
(for 3Z4S-LE VS-MCA series)

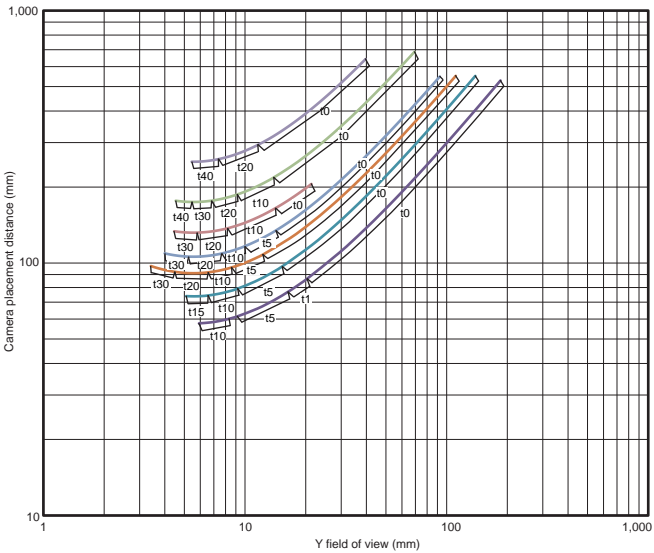
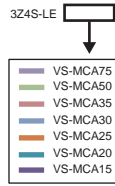

Safety Precautions

Precautions on Safety

Meaning of Signal Word

In order for the product to be used safely, the following indication is used in this catalog to draw your attention to the cautions. The cautions with the indication describe the important contents for safety.



WARNING

Indicates a potentially hazardous situation which, if not avoided, will result in minor or moderate injury, or may result in serious injury or death. Additionally there may be significant property damage.



CAUTION

Indicates a potentially hazardous situation which, if not avoided, may result in minor or moderate injury or property damage.

Meaning of Alert Symbol



Indicates general prohibitions for which there is no specific symbol.

Alert Statements



WARNING

This product is not designed or rated for ensuring safety of persons. Do not use it for such purposes.



It may cause permanent damage to vision. Do not look directly at the sun through the lens.



Precautions for Safe Use

The following points are important to ensure safety, so make sure that they are strictly observed.

1. Installation and Storage Sites

Do not install and store the product in locations subjected to the following conditions:

- Ambient temperature outside the rating
- Rapid temperature fluctuations (causing condensation)
- Presence of corrosive or flammable gases
- Presence of dust, salt, or iron particles
- Direct vibration or shock
- Strong ambient light (such as other laser beams or light from arc-welding machines)
- Direct sunlight or near heaters
- Water, oil, or chemical fumes or spray
- Near high-voltage equipment or power equipment

2. Installation

- Make sure to tighten all installation screws securely

3. Others

- Do not attempt to dismantle, repair, or modify the product.
- Do not drop, impose excessive vibration or shock on the product.
- If you notice an abnormal condition, immediately stop using the product and consult your OMRON representative.
- Be sure to dispose of the product as industrial waste.

Precautions for Correct Use

Observe the following precautions to prevent failure to operate, malfunctions, or undesirable effects on product performance.

1. Maintenance

- Clean the lens with a lens-cleaning cloth or air brush.
- Avoid blowing off foreign matter with your breath. Do not use thinner, benzene, acetone, or kerosene.

2. Using with Product from Other Manufacturer

- Refer to the manual of the product from other manufacturer for installation and replacement.

3. Others

- After removing the lens from the camera, do not leave it in a place exposed to direct sunlight. Failure to do so may cause a fire.

Terms and Conditions Agreement

Read and understand this catalog.

Please read and understand this catalog before purchasing the products. Please consult your OMRON representative if you have any questions or comments.

Warranties.

- (a) Exclusive Warranty. Omron's exclusive warranty is that the Products will be free from defects in materials and workmanship for a period of twelve months from the date of sale by Omron (or such other period expressed in writing by Omron). Omron disclaims all other warranties, express or implied.
- (b) Limitations. OMRON MAKES NO WARRANTY OR REPRESENTATION, EXPRESS OR IMPLIED, ABOUT NON-INFRINGEMENT, MERCHANTABILITY OR FITNESS FOR A PARTICULAR PURPOSE OF THE PRODUCTS. BUYER ACKNOWLEDGES THAT IT ALONE HAS DETERMINED THAT THE PRODUCTS WILL SUITABLY MEET THE REQUIREMENTS OF THEIR INTENDED USE.

Omron further disclaims all warranties and responsibility of any type for claims or expenses based on infringement by the Products or otherwise of any intellectual property right. (c) Buyer Remedy. Omron's sole obligation hereunder shall be, at Omron's election, to (i) replace (in the form originally shipped with Buyer responsible for labor charges for removal or replacement thereof) the non-complying Product, (ii) repair the non-complying Product, or (iii) repay or credit Buyer an amount equal to the purchase price of the non-complying Product; provided that in no event shall Omron be responsible for warranty, repair, indemnity or any other claims or expenses regarding the Products unless Omron's analysis confirms that the Products were properly handled, stored, installed and maintained and not subject to contamination, abuse, misuse or inappropriate modification. Return of any Products by Buyer must be approved in writing by Omron before shipment. Omron Companies shall not be liable for the suitability or unsuitability or the results from the use of Products in combination with any electrical or electronic components, circuits, system assemblies or any other materials or substances or environments. Any advice, recommendations or information given orally or in writing, are not to be construed as an amendment or addition to the above warranty.

See <http://www.omron.com/global/> or contact your Omron representative for published information.

Limitation on Liability; Etc.

OMRON COMPANIES SHALL NOT BE LIABLE FOR SPECIAL, INDIRECT, INCIDENTAL, OR CONSEQUENTIAL DAMAGES, LOSS OF PROFITS OR PRODUCTION OR COMMERCIAL LOSS IN ANY WAY CONNECTED WITH THE PRODUCTS, WHETHER SUCH CLAIM IS BASED IN CONTRACT, WARRANTY, NEGLIGENCE OR STRICT LIABILITY.

Further, in no event shall liability of Omron Companies exceed the individual price of the Product on which liability is asserted.

Suitability of Use.

Omron Companies shall not be responsible for conformity with any standards, codes or regulations which apply to the combination of the Product in the Buyer's application or use of the Product. At Buyer's request, Omron will provide applicable third party certification documents identifying ratings and limitations of use which apply to the Product. This information by itself is not sufficient for a complete determination of the suitability of the Product in combination with the end product, machine, system, or other application or use. Buyer shall be solely responsible for determining appropriateness of the particular Product with respect to Buyer's application, product or system. Buyer shall take application responsibility in all cases.

NEVER USE THE PRODUCT FOR AN APPLICATION INVOLVING SERIOUS RISK TO LIFE OR PROPERTY OR IN LARGE QUANTITIES WITHOUT ENSURING THAT THE SYSTEM AS A WHOLE HAS BEEN DESIGNED TO ADDRESS THE RISKS, AND THAT THE OMRON PRODUCT(S) IS PROPERLY RATED AND INSTALLED FOR THE INTENDED USE WITHIN THE OVERALL EQUIPMENT OR SYSTEM.

Programmable Products.

Omron Companies shall not be responsible for the user's programming of a programmable Product, or any consequence thereof.

Performance Data.

Data presented in Omron Company websites, catalogs and other materials is provided as a guide for the user in determining suitability and does not constitute a warranty. It may represent the result of Omron's test conditions, and the user must correlate it to actual application requirements. Actual performance is subject to the Omron's Warranty and Limitations of Liability.

Change in Specifications.

Product specifications and accessories may be changed at any time based on improvements and other reasons. It is our practice to change part numbers when published ratings or features are changed, or when significant construction changes are made. However, some specifications of the Product may be changed without any notice. When in doubt, special part numbers may be assigned to fix or establish key specifications for your application. Please consult with your Omron's representative at any time to confirm actual specifications of purchased Product.

Errors and Omissions.

Information presented by Omron Companies has been checked and is believed to be accurate; however, no responsibility is assumed for clerical, typographical or proofreading errors or omissions.

Note: Do not use this document to operate the Unit.

OMRON Corporation Industrial Automation Company

Kyoto, JAPAN

Contact : www.ia.omron.com

Regional Headquarters

OMRON EUROPE B.V.

Wegalaan 67-69, 2132 JD Hoofddorp
The Netherlands

Tel: (31) 2356-81-300 Fax: (31) 2356-81-388

OMRON ELECTRONICS LLC

2895 Greenspoint Parkway, Suite 200
Hoffman Estates, IL 60169 U.S.A.

Tel: (1) 847-843-7900 Fax: (1) 847-843-7787

OMRON ASIA PACIFIC PTE. LTD.

438B Alexandra Road, #08-01/02 Alexandra
Technopark, Singapore 119968

Tel: (65) 6835-3011 Fax: (65) 6835-3011

OMRON (CHINA) CO., LTD.

Room 2211, Bank of China Tower,
200 Yin Cheng Zhong Road,
PuDong New Area, Shanghai, 200120, China

Tel: (86) 21-6023-0333 Fax: (86) 21-5037-2388

Authorized Distributor:

©OMRON Corporation 2013-2023 All Rights Reserved.
In the interest of product improvement,
specifications are subject to change without notice.

CSM_15_3

Cat. No. Q198-E1-21 0823 (1213)