

## Parallel Beam Linear Sensor

## Z4LB V2

### Thru-beam Linear Sensor Featuring Space-saving Head and Easy-to-use Amplifier

- Visible light ensures ease of optical axis adjustment for Standard Sensors.
- Sensor head for 10-mm model is one third the size of that used with earlier models such as the Z4LA.
- Digital display allows measured values to be read easily.
- Features hold functions, bank functions and functions for setting discrimination output according to the application.
- Connector cables between the Sensor and Amplifier and DIN Track mounting ensure easy installation.
- Side-view Attachment with 10-mm models also contributes to space saving.



### Ordering Information

#### ■ Sensors/Amplifiers

##### Sensors on Standard Models

Sensing distance	Measurement width	Model
 0 to 300 mm	10 mm	Z4LB-S10V2
	30 mm	Z4LB-S30V2

##### Amplifiers on Standard Models

NPN model	PNP model
Z4LB-CV2	Z4LB-CPV2

##### One-side Interruption High-precision Models (Set for sensor and amplifier)

Sensing distance	Measurement width	NPN models	PNP models
 40 mm (fixed)	10 mm	Z4LB-A1040V2	Z4LB-A1040PV2
	30 mm	Z4LB-A3040V2	Z4LB-A3040PV2

#### ■ Accessories (Sold Separately)

##### Extension Cable

Application	Model	Length
Connection between Sensor and Amplifier	Z49-C13	3 m
		8 m

**Note:** The Extension Cable comes in a set for receiver and emitter. When ordering, specify the length required as well as the model number.

##### Side-view Attachment

Application	Model	
Vertical beam 	Emitter	Z49-F2L
	Receiver	Z49-F2D
Horizontal beam 	Emitter	Z49-F3L
	Receiver	Z49-F3D

# Specifications

## ■ Ratings

Item		Standard Models (Separate Type)		One-side Interruption High-precision Models (Integrated Type)	
Sensors		Z4LB-S10V2	Z4LB-S30V2	---	---
Amplifiers/One-side Interruption High-precision Models	NPN Models	Z4LB-CV2		Z4LB-A1040V2	Z4LB-A3040V2
	PNP Models	Z4LB-CPV2		Z4LB-A1040PV2	Z4LB-A3040PV2
Light source (emission wavelength)		Visible-light semiconductor laser (Wavelength: 650 nm, IEC Class 1, FDA Class II)			
Measurement width		10 mm	30 mm	10 mm	30 mm
Sensing distance		0 to 300 mm		40 mm	
Minimum sensing object		0.1 mm dia.	0.2 mm dia.	0.1 mm dia.	0.2 mm dia.
Response time (see note 1)		0.3 or 5 ms (switch-selectable)			
Linear output	Output voltage	1 to 5 V (output impedance: 100 Ω, allowable load resistance: 10 kΩ min.)			
	Resolution (see note 2)	5 μm (5 ms), 10 μm (0.3 ms)	15 μm (5 ms), 30 μm (0.3 ms)	5 μm (5 ms), 10 μm (0.3 ms)	15 μm (5 ms), 30 μm (0.3 ms)
	Linearity	---		±0.5% F.S. (see notes 3, 5)	
	Temperature characteristic	Sensor	0.1% F.S./°C (see notes 4, 5)		
		Amplifier	0.02% F.S./°C (see notes 4, 5)		
Control outputs	Discrimination outputs HIGH, LOW (PASS, NG)	NPN models	NPN open-collector outputs: 100 mA max. at 30 VDC Residual voltage: 1.2 V max.		
		PNP models	PNP open-collector outputs: 100 mA max. at 30 VDC Residual voltage: 2.0 V max.		
Control inputs	LD OFF input Timing input Forced-zero input Bank selection in- put Hold reset input	NPN models	ON: 0 V short-circuited or 1.5 V max. OFF: Open (leakage current: 0.1 mA max.)		
		PNP models	ON: Power supply voltage short-circuited or power supply voltage -1.5 V max. OFF: Open (leakage current: 0.1 mA max.)		
Main functions		Measured value display, hold, bank selection, discrimination outputs, scaling			
Power supply voltage		12 to 24 VDC ±10% ripple (p-p): 10% max.			
Current consumption		200 mA max.			
Ambient illumination		3,000 lx max. (incandescent lamp)			
Ambient temperature		Operating: 0 to 50°C Storage: -15 to 60°C (with no icing)			
Ambient humidity		Operating: 35% to 85% (with no condensation) Storage: 35% to 85% (with no condensation)			
Vibration resistance	Sensor	10 to 150 Hz, half-amplitude of 0.75 mm, acceleration of 100 m/s <sup>2</sup> max.			
	Amplifier	10 to 150 Hz, half-amplitude of 0.15 mm, acceleration of 20 m/s <sup>2</sup> max.			
Dielectric strength	Sensor	1,000 VAC, 50/60 Hz, 1 min			
	Amplifier	300 VAC, 50/60 Hz, 1 min			
Degree of protection		IEC60529 IP40			
Connection method		Cable with connector (standard length of cable for Sensor: 2 m; standard length of cable for Amplifier: 2 m)			
Material		Sensor: Diecast zinc, Amplifier: ABS			
Weight (including package) (see note 6)	Sensor/One- side Interruption High-precision Model	Approx. 310 g (emitter: approx. 110 g; receiver: approx. 105 g; includes 2-m cable)	Approx. 790 g (emitter: approx. 230 g; receiver: approx. 195 g; includes 2-m cable)	Approx. 610 g (Sensor: approx. 280 g; Amplifier: approx. 210 g; includes 2-m cable)	Approx. 900 g (Sensor: approx. 510 g; Amplifier: approx. 210 g; includes 2-m cable)
	Amplifier	Approx. 450 g (Amplifier: approx. 210 g; includes 2-m cable)		---	
Accessories		Mounting brackets, instruction manual, label		Instruction manual, label	

- Note:** 1. The response time is the rising time (i.e., the time required to go from 10% to 90% of the maximum output) or falling time (i.e., the time required to go from 90% to 10% of the maximum output) for linear output when the light interruption period is rectangular in shape as shown below:

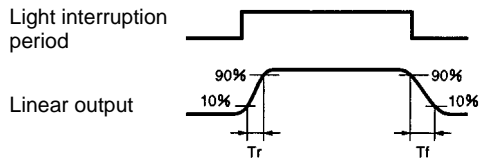

2. The resolution values are conversion values for peak-to-peak linear outputs.  
 3. Linearity: The value deviated from the ideal straight line measured at the center point between the emitter and the receiver with 5% to 95% F.S. one-side light interruption. For the Z4LB-A1040V2, the range is from 0.5 to 9.5 mm.

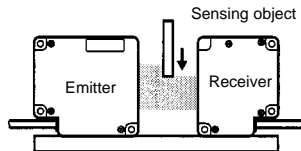

4. The values given for temperature characteristics are typical values for the Sensor or the Amplifier alone.  
 A typical value for the temperature characteristic when the Z49-F□□ Side-view Attachment is mounted is 0.3% F.S./°C (at sensing distance = 300 mm).  
 5. "F.S." stands for full scale. In the case of the Z4LB-S10V2, for example, the F.S. value is 10 mm.  
 6. The weight of the Z49-F□□ Side-view Attachment is approx. 50 g.

# Engineering Data

## ■ Linearity

(WD: distance between receiver and workpiece)

**Z4LB-S10V2 (Sensing distance: 300 mm)**

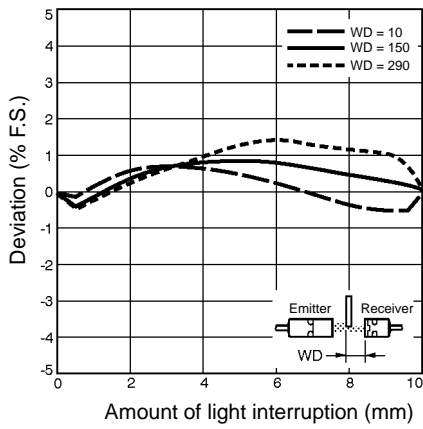

**Z4LB-S30V2 (Sensing distance: 300 mm)**

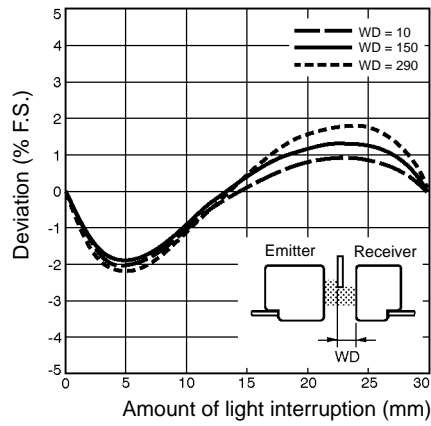

**Z4LB-A1040V2 (Sensing distance: 40 mm)**

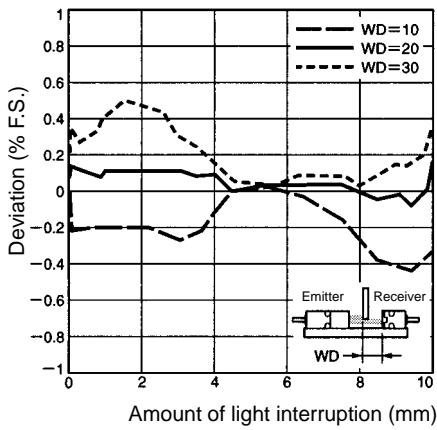

**Z4LB-A3040V2 (Sensing distance: 40 mm)**

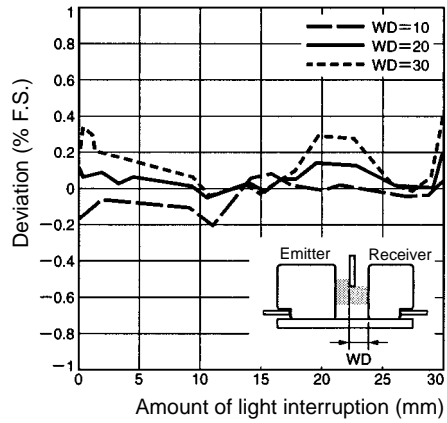

■ Deviation according to Position of a Round Rod

(Sensing distance: 300 mm; WD: distance between receiver and workpiece)

Z4LB-S10V2 (Diameter of rod = 1 dia.)

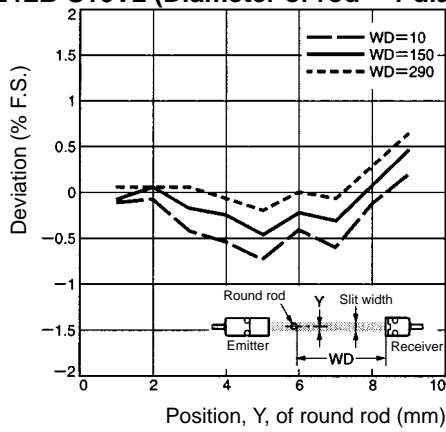

Z4LB-S30V2 (Diameter of rod = 1 dia.)

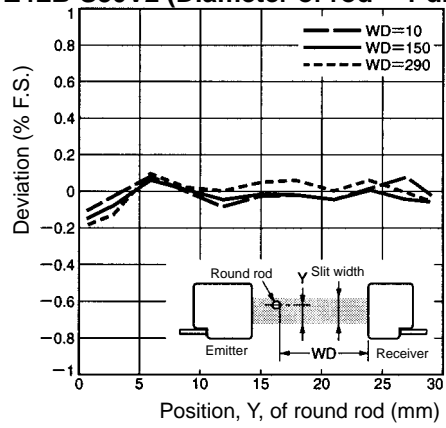

Z4LB-S10V2 (Diameter of rod = 5 dia.)

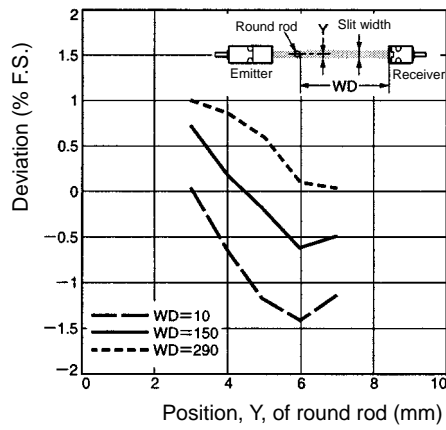

Z4LB-S30V2 (Diameter of rod = 10 dia.)

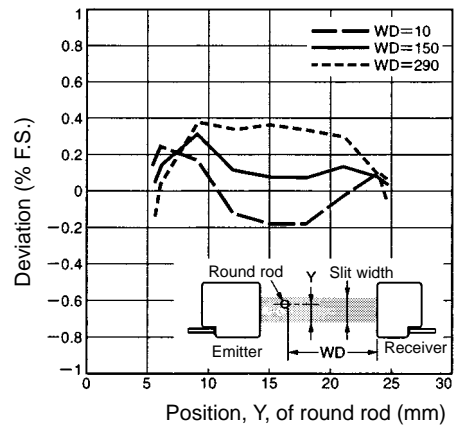

# Nomenclature

**Sensor**  
**Z4LB-S10V2**  
**Z4LB-A1040□V2**

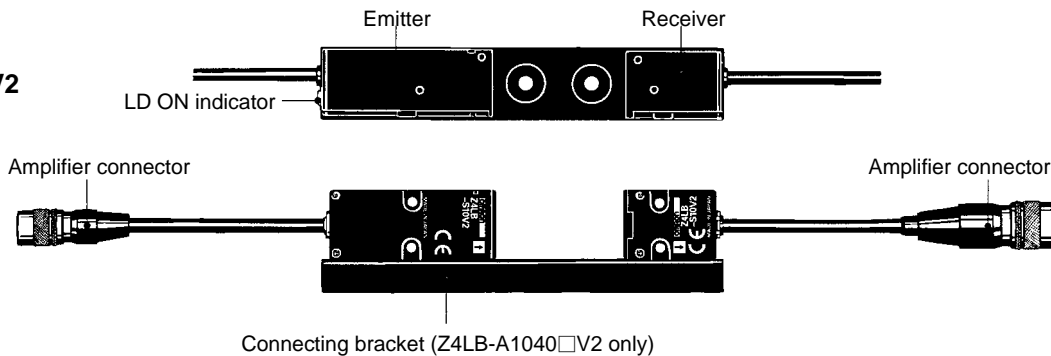

**Z4LB-S30V2**  
**Z4LB-A3040□V2**

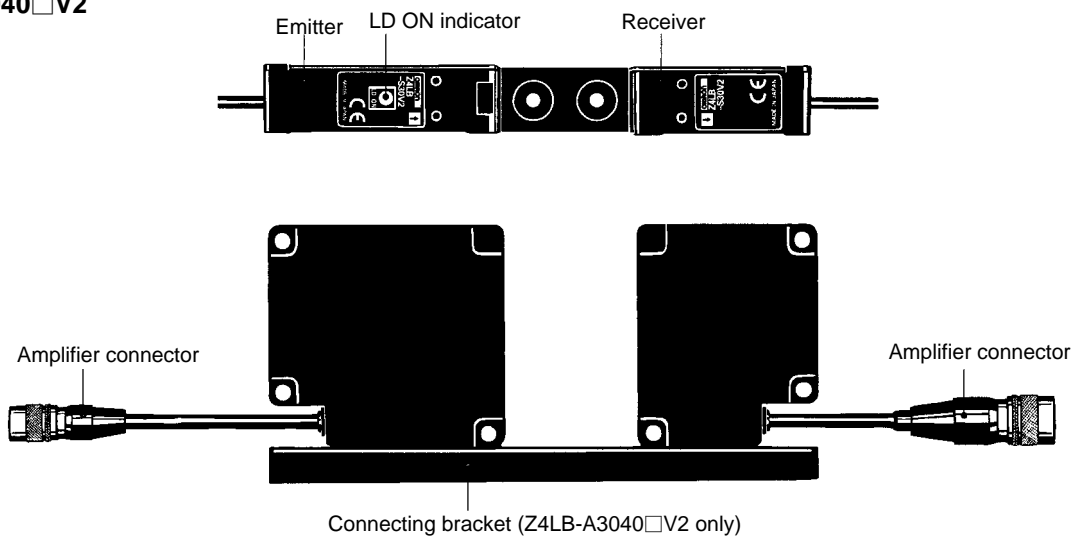

**Amplifier**  
**Z4LB-C□V2**  
**Z4LB-A1040□V2**  
**Z4LB-A3040□V2**

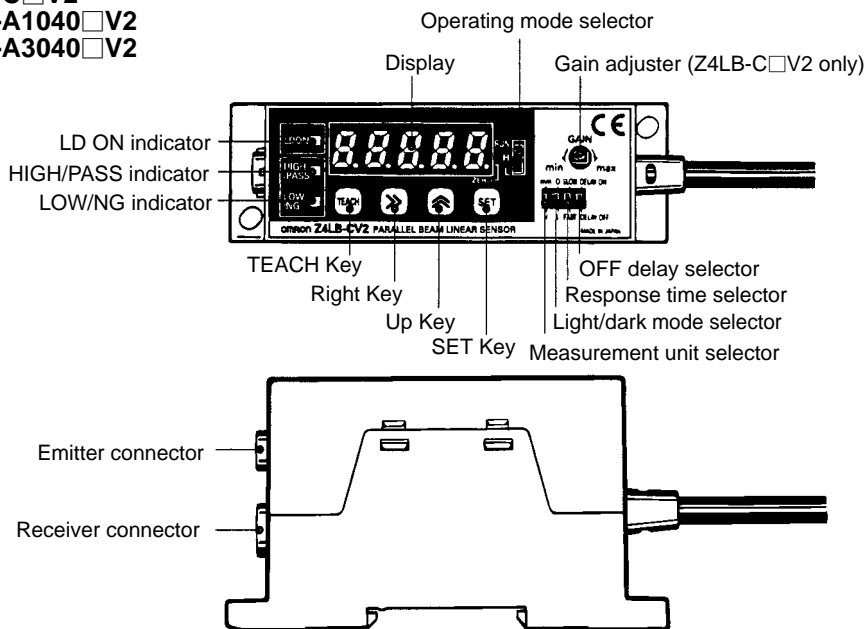

# Operation

## ■ Functions

	Function	Description
Display functions	LD ON indicator	Lights when laser beams are emitted. The Sensor and Amplifier indicators light at the same time.
	Display (with measurement unit selection and light/dark mode selection functions)	Displays either linear output voltage (V) or length (mm) according to the measurement unit selector switch setting. If the measurement unit is set to length (mm), set the measurement width to be used. The default setting is 10 mm. The amount of incident light or light interruption can be selected using the light/dark mode selector switch.
	HIGH/PASS indicator	Lights when HIGH/PASS discrimination output turns ON.
	LOW/NG indicator	Lights when LOW/NG discrimination output turns ON.
	Forced-zero indicator (displayed as the lowest decimal place)	Lights when the forced-zero settings are enabled in RUN mode.
Output functions	Linear output (with light/dark mode selection function)	Outputs voltage (1 to 5 VDC) proportional to the amount of incident light or light interruption. The light/dark mode selector switch is used to select either light or dark mode. <div style="display: flex; justify-content: space-around; align-items: flex-end;"> <div style="text-align: center;"> <p><b>Light mode</b></p> </div> <div style="text-align: center;"> <p><b>Dark mode</b></p> </div> </div>
	HIGH/PASS output (with discrimination output setting and short-circuit protection functions)	One of the following discrimination output modes can be selected according to the application. HIGH/LOW Output Mode: Turns ON when measured value $\leq$ HIGH threshold PASS/NG Output Mode: Turns ON when LOW threshold < measured value < HIGH threshold HIGH/LOW Inverted Output Mode: Turns ON when measured value $\geq$ HIGH threshold The default setting is HIGH/LOW Output Mode.
	LOW/NG output (with discrimination output setting and short-circuit protection functions)	One of the following discrimination output modes can be selected according to the application. HIGH/LOW Output Mode: Turns ON when measured value $\geq$ LOW threshold PASS/NG Output Mode: Turns ON when measured value $\leq$ LOW threshold or measured value $\geq$ HIGH threshold HIGH/LOW Inverted Output Mode: Turns ON when measured value $\leq$ LOW threshold The default setting is HIGH/LOW Output Mode.

Function	Description								
Input functions	LD OFF input Laser beams will be stopped when this input turns ON. "LD OFF" appears on the display, and linear output, HIGH/LOW discrimination indicator and output remain in the previous state. All displays except the LD ON indicator and all outputs retain the previous values.								
	Forced-zero input Displays the measured value as zero when the unit is set to length (mm). The value is set if forced-zero input is ON for 0.2 to 0.8 s and cleared if it is ON for 1 s or more. To set forced-zero or clear forced-zero, press and hold down the SET Key for 3 s while in RUN mode.								
	Timing input Forcibly turns OFF HIGH/PASS or LOW/NG discrimination output if this input turns ON during "normal" measurement. Controls sampling timing if this input turns ON during "hold" measurement. The default setting is "normal."								
	Bank selection input The Z4LB V2 has two banks in which thresholds can be set independently. If the bank selection input is enabled, the thresholds to be used for judgment can be switched. The default setting is "disabled." <table border="1" data-bbox="625 689 1177 833"> <thead> <tr> <th>Bank</th> <th>NPN type</th> <th>PNP type</th> </tr> </thead> <tbody> <tr> <td>Bank 1</td> <td>Open or connected to 12 to 24 VDC</td> <td>Open or connected to 0 V</td> </tr> <tr> <td>Bank 2</td> <td>Connected to 0 V</td> <td>Connected to 12 to 24 VDC</td> </tr> </tbody> </table>	Bank	NPN type	PNP type	Bank 1	Open or connected to 12 to 24 VDC	Open or connected to 0 V	Bank 2	Connected to 0 V
Bank	NPN type	PNP type							
Bank 1	Open or connected to 12 to 24 VDC	Open or connected to 0 V							
Bank 2	Connected to 0 V	Connected to 12 to 24 VDC							
Hold reset input	Resets the held value if this input turns ON during "hold" measurement.								
Threshold setting function	Direct setting The thresholds are set to desired values by using the Right Key, Up Key, and SET Key.								
	Teaching setting The thresholds are set to desired values by teaching. The HIGH threshold output turns ON when the HIGH threshold is equal to or below a measured value. The LOW threshold output turns ON when the LOW threshold is equal to or above a measured value.								
Hold (See below)	Holds the display and output values. One of the following six hold methods can be selected according to the application: Peak hold, bottom hold, sample hold, peak-to-peak hold, self-peak hold, self-bottom hold. The default setting is "normal."								
Backup	Specifies whether to back up the forced-zero set value. If the value is to be retained after the Sensor is turned OFF, always enable the backup. The default setting is "enabled".								
Response time selection	The resolution changes with the response time. Select the required response time, taking the resolution into consideration. <table border="1" data-bbox="625 1355 919 1442"> <thead> <tr> <th>Switch</th> <th>Response time</th> </tr> </thead> <tbody> <tr> <td>FAST</td> <td>0.3 ms</td> </tr> <tr> <td>SLOW</td> <td>5 ms</td> </tr> </tbody> </table>	Switch	Response time	FAST	0.3 ms	SLOW	5 ms		
Switch	Response time								
FAST	0.3 ms								
SLOW	5 ms								
OFF delay	The HIGH/LOW discrimination outputs will have a 40-ms OFF delay if the OFF delay selector is set to ON.								
Gain adjustment (for standard model only)	Adjusts the full scale of linear output and display.								



Function Settings with Keys

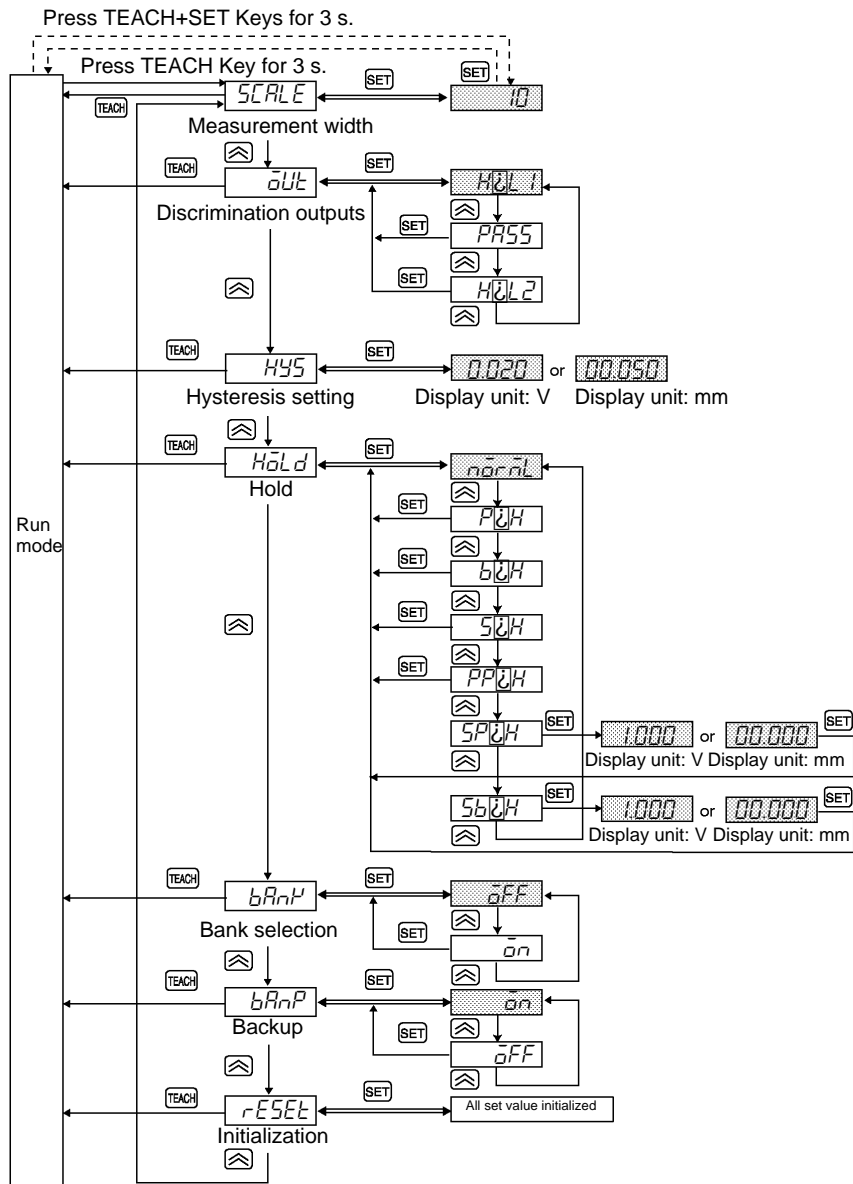

\* Shaded settings are the default settings.

■ Hold Functions

Normal

Measurement is performed continuously and measurement results are displayed and output.

Peak Hold and Bottom Hold

The maximum or the minimum value while the timing input is ON is displayed, output, and held. The discrimination outputs are controlled according to the displayed value and output value.

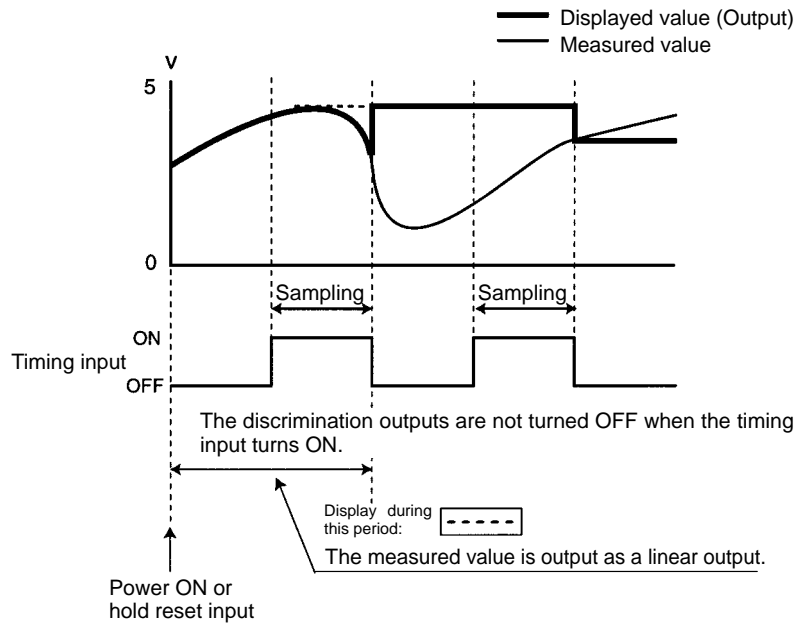

Sample Hold

The current value when the timing input turns ON is displayed, output, and held. The discrimination outputs are controlled according to the displayed value and output value.

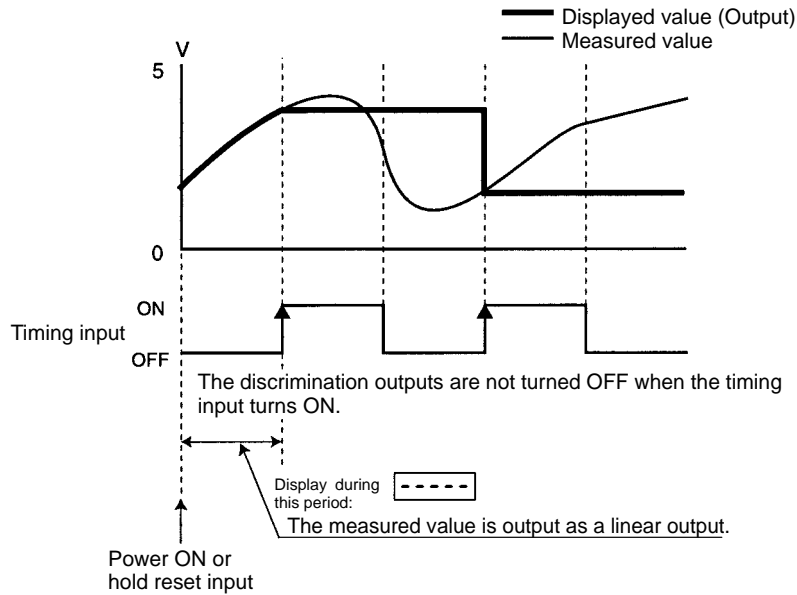

**Peak-to-peak Hold**

The difference between the maximum and minimum values while timing input is ON is displayed, output, and held. The discrimination outputs are controlled according to the displayed value and output value.

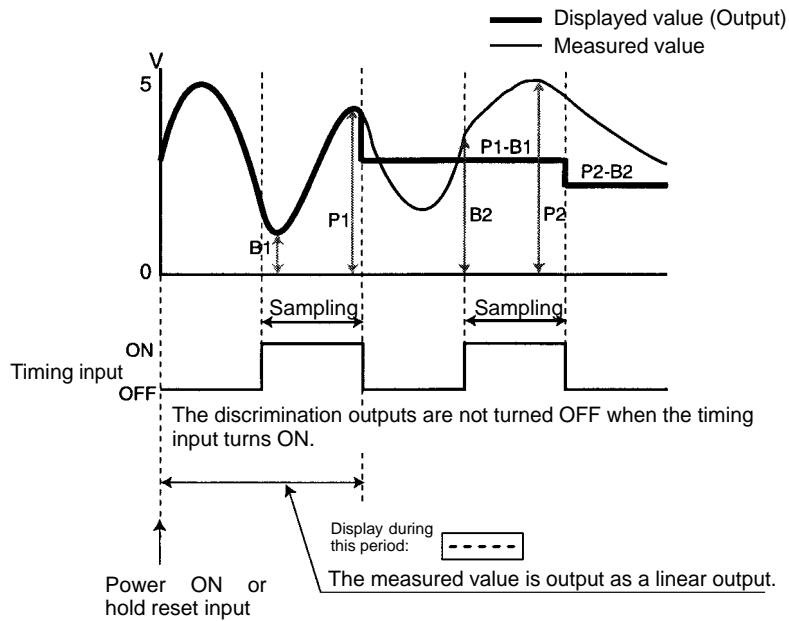

**Self-peak Hold and Self-bottom Hold**

The maximum value (self-peak hold) or the minimum value (self-bottom hold) while the measured value is equal to or greater than the trigger level (self-peak hold), or is equal to or smaller than the trigger level (self-bottom hold), is displayed, output, and held. The discrimination outputs are controlled according to the displayed value and output value.

**Note:** No sampling is performed when the timing input is ON.

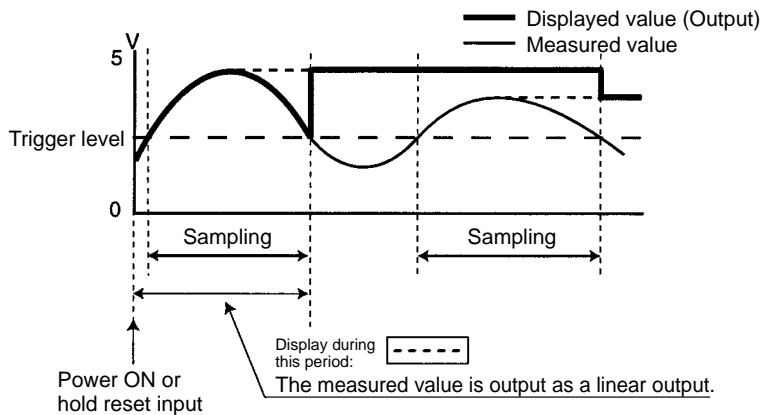

**I/O Stage Circuit Diagrams**

**NPN Models**

**Standard Model:**

**Z4LB-CV2**

**High-precision Models:**

**Z4LB-A□□V2**

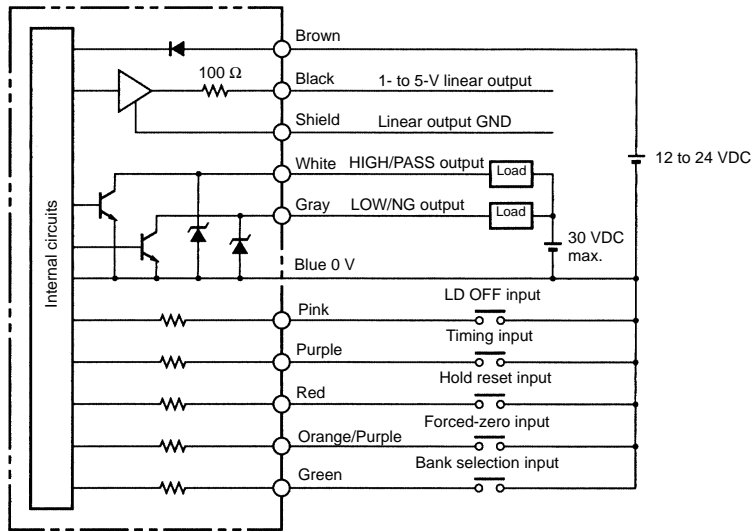

**PNP Models**

**Standard Model:**

**Z4LB-CPV2**

**High-precision Models:**

**Z4LB-A□□PV2**

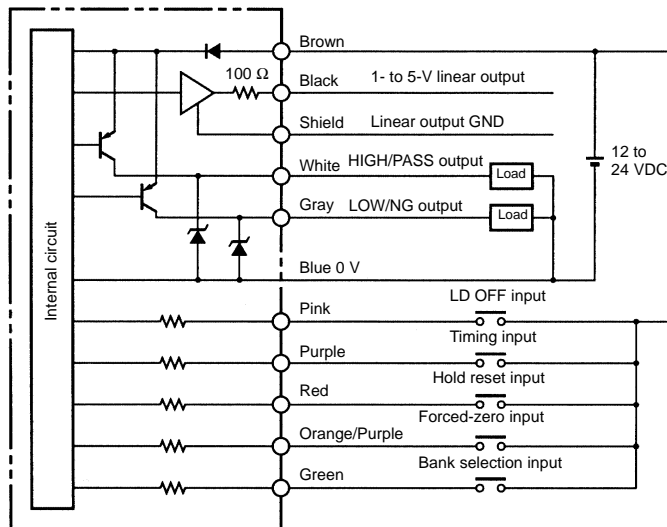

# Dimensions

Note: All units are in millimeters unless otherwise indicated.

## Sensor Z4LB-S10V2

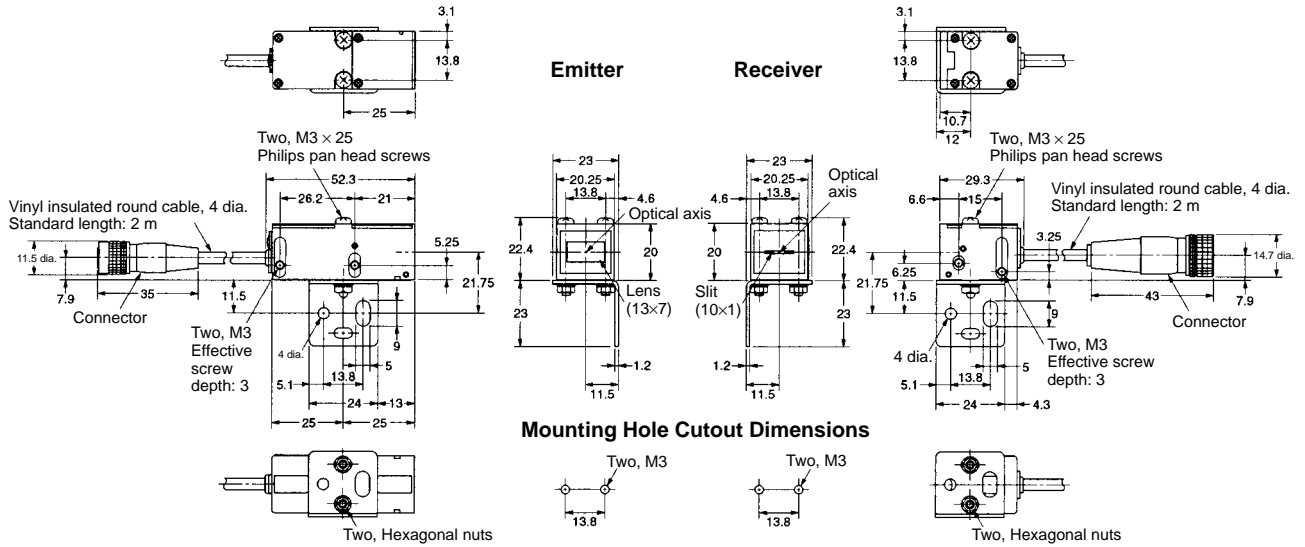
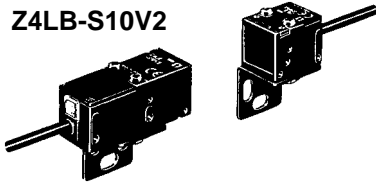

## Sensor Z4LB-A1040□V2

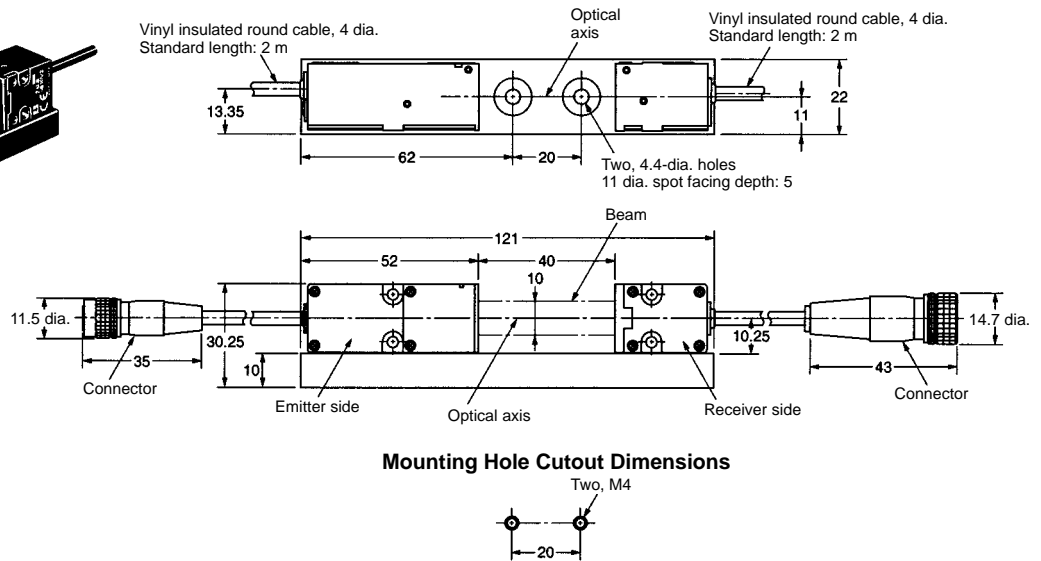
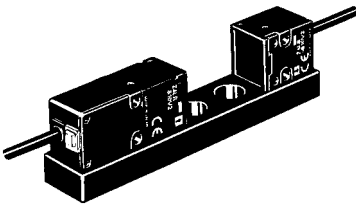

**Sensor**  
**Z4LB-S30V2**

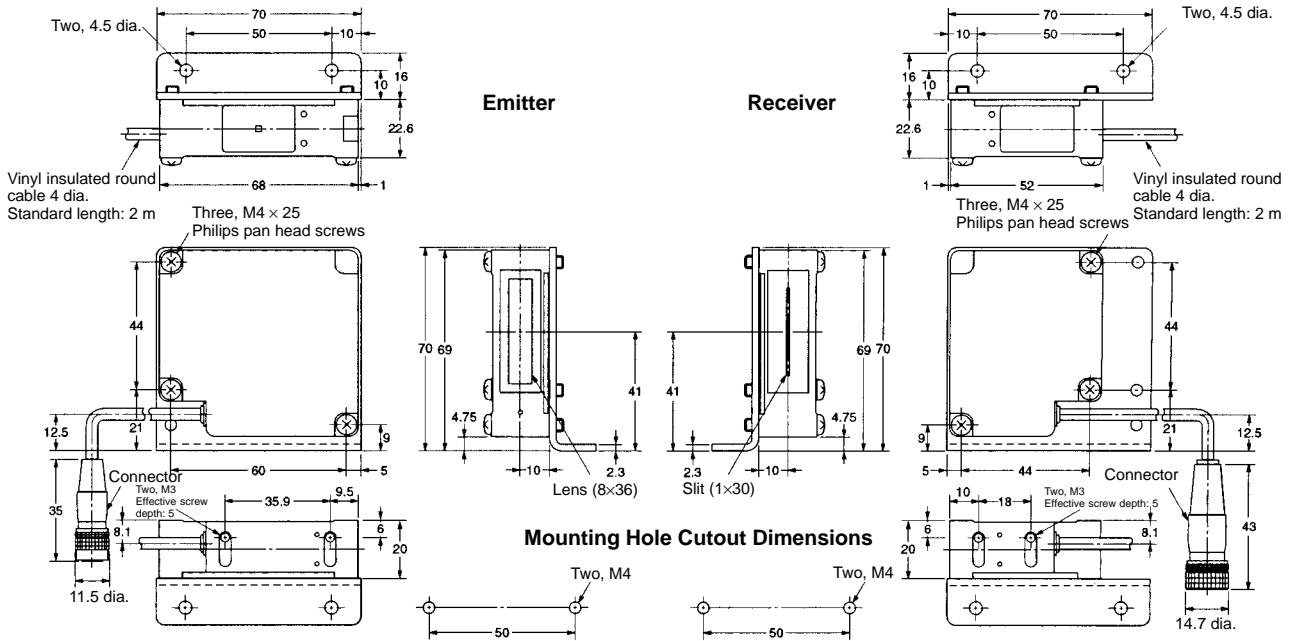
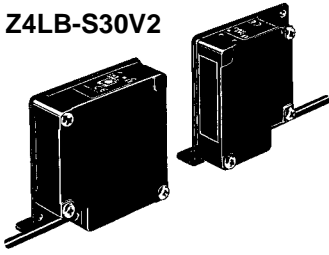

**Sensor**  
**Z4LB-A3040 V2**

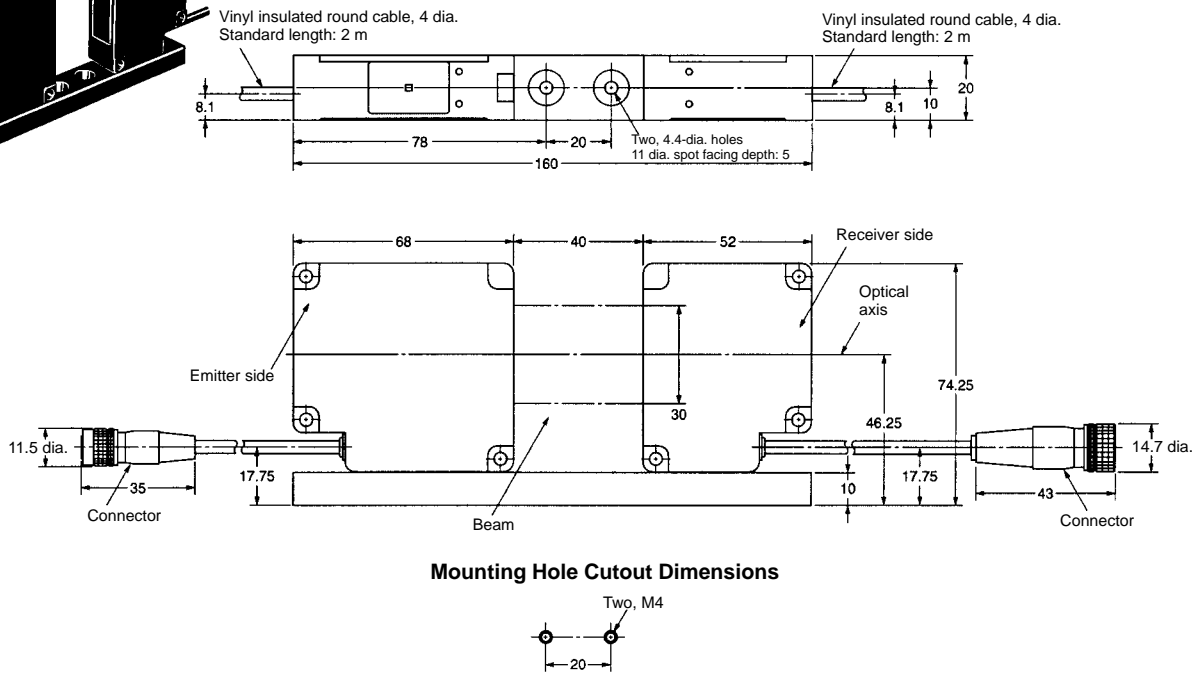
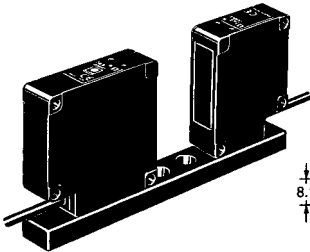

**Amplifier**

Z4LB-C□V2  
 Z4LB-A1040□V2  
 Z4LB-A3040□V2

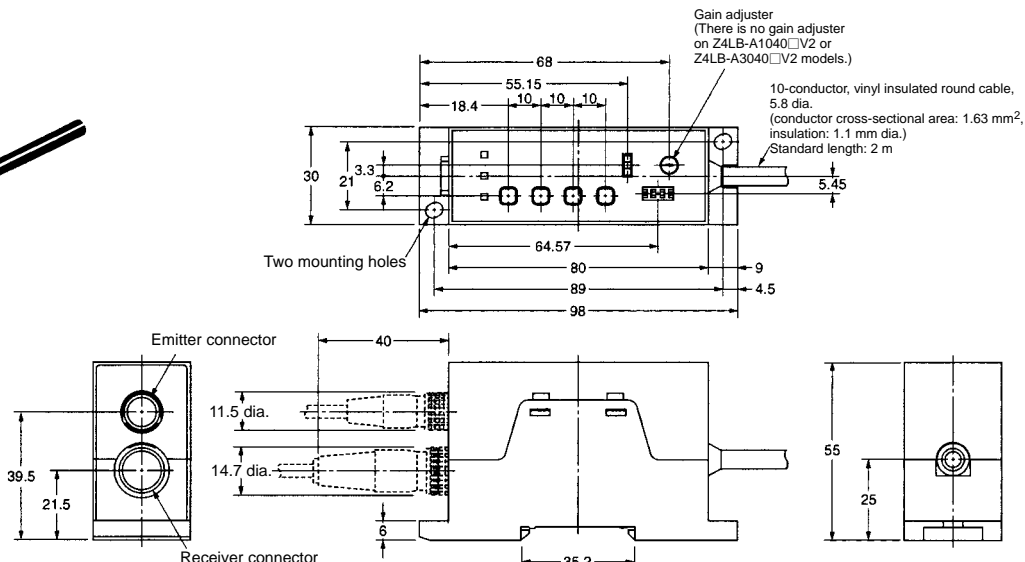
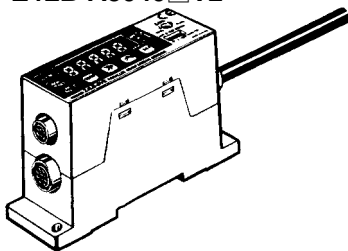

**Mounting Hole Cutout Dimensions**

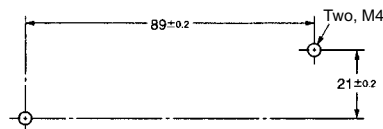

**Side-view Attachment  
 Vertical Beam  
 Z49-F2L (For Emitter)**

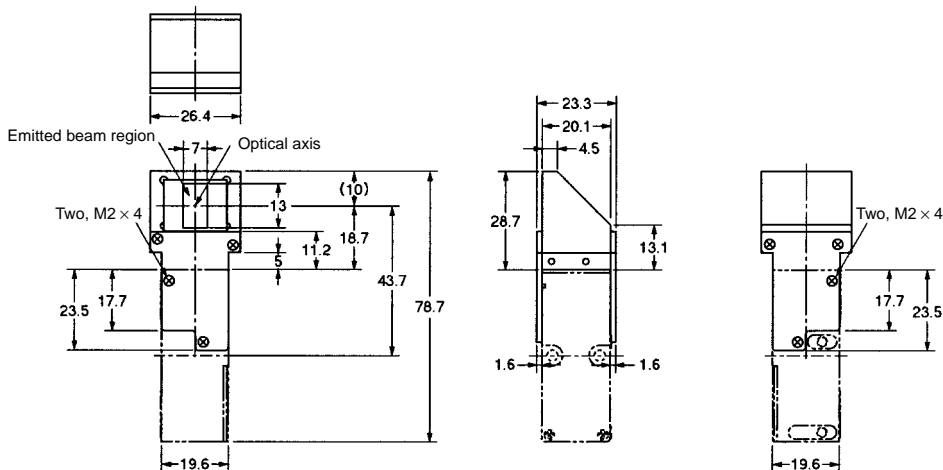

**Side-view Attachment  
 Vertical Beam  
 Z49-F2D (For Receiver)**

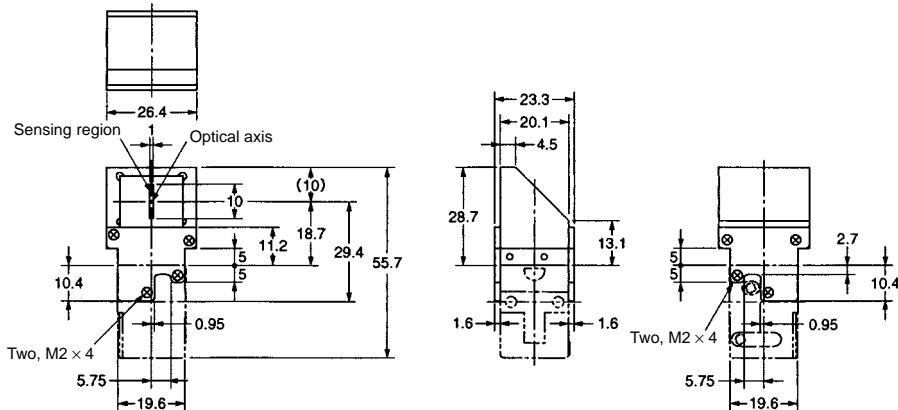

**Side-view Attachment  
Horizontal Beam  
Z49-F3L (For Emitter)**

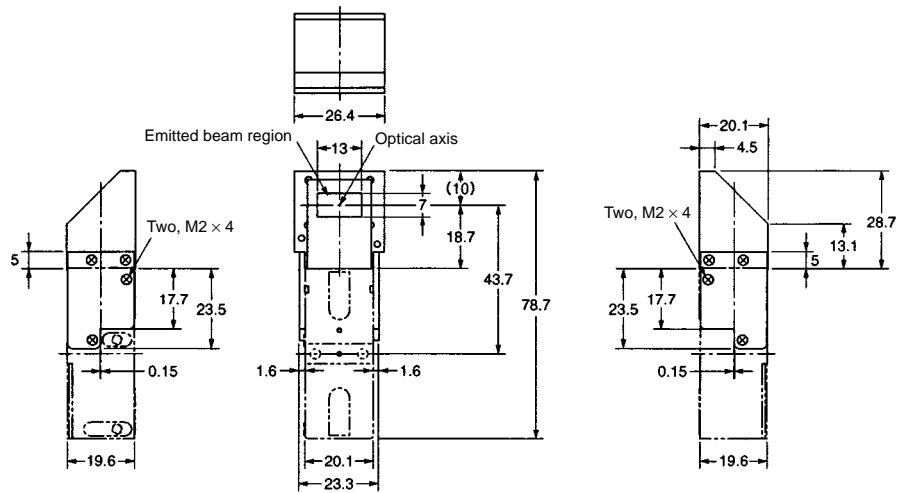

**Side-view Attachment  
Horizontal Beam  
Z49-F3D (For Receiver)**

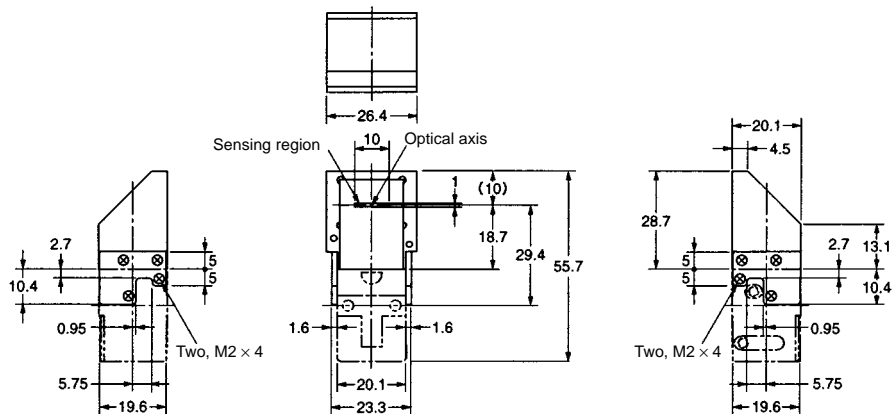

**Installation**

■ **Wiring**

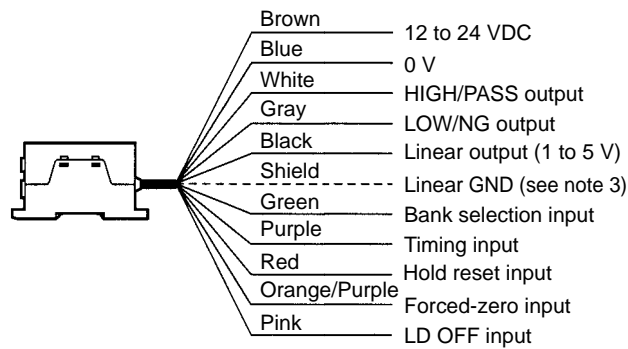

- Note:**
1. When particularly high resolutions are required, prepare a separate, stable power supply.
  2. Perform wiring correctly. Failure to do so may result in damage to the Sensor. In particular, ensure that the wire for linear output does not come into contact with other wires.
  3. 0 V (blue) and linear GND (shield) are connected internally passing through a resistance. Use the blue one (0 V) to supply power, and use the shielded wire (linear GND) together with the black wire (linear output) for linear output.



# Precautions

## ■ Designing the Setup

### Compatibility

There is general compatibility between Sensors and Amplifiers for standard models. However, the emitters and the receivers are inspected as sets before delivery. Operation is possible using the emitters or the receivers from other sets, but in order to satisfy specifications, the serial number of the emitter and the receiver must be the same.

With high-precision models, the Sensor and the Amplifier are adjusted as a set. Only use combinations with the same serial number.

### Mutual Interference

Operation is possible with two or more Sensors mounted together, but operation is not possible with two or more beams in close proximity. If the Sensor is used in this way, it may cause malfunction.

## ■ Wiring Precautions

### Wiring and Power Supply

Do not impose voltage exceeding the rated voltage, otherwise the Sensor may be damaged.

When supplying power to the Sensor, make sure that the polarity of the power is correct, otherwise, the Sensor may be damaged.

Do not short-circuit the load supplied with open collector output, otherwise the Sensor may be damaged.

Do not lay a power supply cable for the Z4LB V2 together with high-voltage lines or power lines to prevent interference, damage, and malfunction.

The Z49-C13 Extension cable (3 or 8 m in length) can be connected to the Sensor cable or Amplifier cable. The total length of the Sensor cable or Amplifier cable, however, must be 10 m or less. Use a shielded cable to extend the Amplifier cable, in which case, a shielded cable that is the same as that of the Amplifier cable must be used.

Use an isolation transformer for the power supply of the Z4LB V2 as shown in the following. Do not use an autotransformer (single-winding transformer).

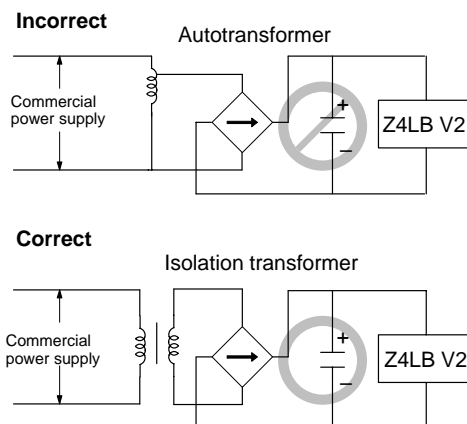

## ■ Other Precautions

### Maintenance

Install the Sensor in a clean environment and keep the filter on the front panel of the Sensor free from oil and dust. If affected by oil or dust, clean the filter as follows:

1. Use a blower brush (used to clean camera lenses) to blow large dust particles from the surface. Do not blow the dust away with your mouth.
2. Use a soft cloth (for lenses) with a small amount of alcohol to remove the remaining dust.

**Note:** Do not use a scrubbing action when cleaning as scratches on the filter could result in the Sensor malfunctioning.

## Environment

Do not use the Sensor in strong electromagnetic fields or in an environment where the operation of the Sensor is subject to the reflection of intense light (such as other laser beams or electric arc-welding machines.)

The Sensor may not be able to accurately detect objects of certain materials or shapes.

## Mounting the Side-view Attachment

### Handling Precautions

Do not apply excessive shock to the Attachment. Doing so may result in damage.

The Attachment can be used attached to either the emitter or the receiver, but not both.

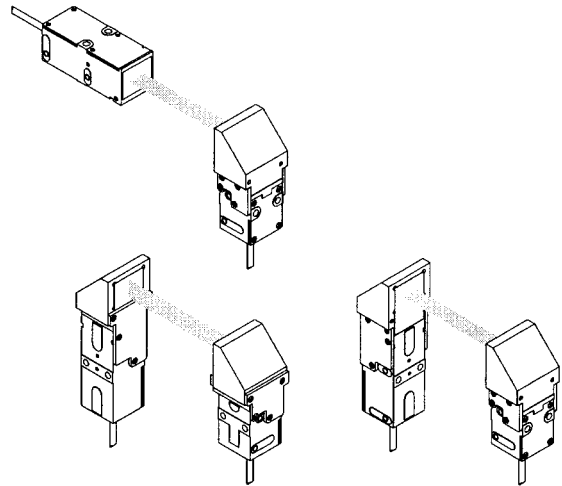

### Mounting Precautions

Do not touch any internal parts when mounting. Dirt inside the Attachment may affect the high-performance reflective mirror inside and cause malfunction.

When mounting the Attachment, tighten the mounting screws to a torque not exceeding 0.2 N • m.

# Laser Safety

The Z4LB V2 Parallel Beam Linear Sensor, is a Class 1 Laser Product according to EN60825-1 (IEC825-1) and a Class II Laser Product according to FDA (21 CFR1040.10) (see note). The Z4LB V2 is meant to be built into final system equipment. Pay special attention to the following precautions for the safe use of the product:

**Note:** Europe: Class 1 of EN60825-1: 1994 = IEC825-1: 1993  
U.S.A.: Class II of FDA (21 CFR1040.10)

1. Use this product as specified in this datasheet. Otherwise, you may be exposed to hazardous laser radiation.
2. Be careful not to expose your eyes directly to the laser radiation or indirectly to laser radiation reflected from mirror or shiny surfaces.
3. To avoid exposure to hazardous laser radiation, do not displace nor remove the protective housing during operation, maintenance, and any other servicing.
4. The user should return the product to OMRON for all repair and servicing.
5. As for other countries, observe the regulations and standards specified by each country.



## ■ Requirements from Regulations and Standards

### EN60825-1 “Safety of Laser Products, Equipment Classification, Requirements and User’s Guide”

#### Summary of Manufacturer’s Requirements

Requirements; Sub-clause	Classification				
	Class 1	Class 2	Class 3A	Class 3B*	Class 4
Description of hazard class	Safe under reasonably foreseeable conditions	Low power; eye protection normally afforded by aversion responses	Same as Class 2. Direct intrabeam viewing with optical aids may be hazardous	Direct intrabeam viewing may be hazardous	High power; diffused reflection may be hazardous
Protective housing	Required for each laser product; limits access necessary for performance of functions of the products				
Safety interlock in protective housing	Designed to prevent removal of the panel until accessible emission values are below the AEL for the class assigned				
Remote control	Not required			Permits easy addition of external interlock in laser installation	
Key control	Not required			Laser inoperative when key is removed	
Emission warning device	Not required			Gives audible or visible warning when laser is switched on or if capacitor bank of pulsed laser is being charged	
Attenuator	Not required			Gives means beside ON/OFF switch to temporarily block beam	
Location controls	Not required		Controls so located that there is no danger of exposure to AEL (see note 2) above Classes 1 or 2 when adjustments are made.		
Viewing optics	Emission from all viewing systems must be below Class 1 AEL's as applicable				
Scanning	Scan failure shall not cause product to exceed its classification				
Class label	Required wording	Figures A and B and specified wording			
Aperture label	Not required			Specified wording required	
Service entry label	Required as appropriate to the class of accessible radiation				
Override interlock label	Required under certain conditions as appropriate to the class of laser used				
User information	Operation manuals must contain instructions for safe use				
Purchasing and service information	Promotion brochures must reproduce classification labels; service manuals must contain safety information				
Medical products	Special calibration instructions required			Special calibration instructions, means for measurement and target-indicator required	
Fibre optic	Cable service connections require tool to disconnect if disconnection breaks protective housing and permits access above Class 1				

\* With respect to the requirements of remote interlock connector, key control, emission warning and attenuator, Class 3B laser products not exceeding five times the AEL of Class 2 in the wavelength range of 400 nm to 700 nm are to be treated as Class 3A laser products.

**Note:** 1. This table is intended to provide a convenient summary of requirements. See text of this standard for complete requirements.

2. AEL: Accessible Emission Limit  
The maximum accessible emission level permitted within a particular class.  
For your reference, see ANSI Z136.1-1993, Section 2.

Symbol and border: black  
Background: yellow

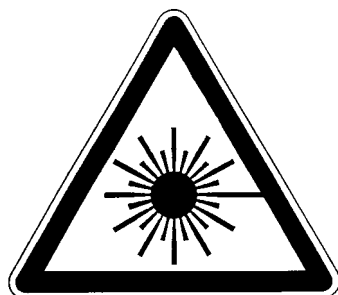

Figure A Warning label – Hazard symbol

Legend and border: black  
Background: yellow



Figure B Explanatory label

FDA (Compliance Guide for Laser Products, 1985, according to 21 CFR1040.10)

Requirements	Class (see note 1)					
	I	Ila	II	IIla	IIlb	IV
<b>Performance (all laser products)</b>						
Protective housing	R (see note 2)	R (see note 2)	R (see note 2)	R (see note 2)	R (see note 2)	R (see note 2)
Safety interlock	R (see notes 3, 4)	R (see notes 3, 4)	R (see notes 3, 4)	R (see notes 3, 4)	R (see notes 3, 4)	R (see notes 3, 4)
Location of controls	N/A	R	R		R	R
Viewing optics	R	R	R	R	R	R
Scanning safeguard	R	R	R	R	R	R
<b>Performance (laser systems)</b>						
Remote control connector	N/A	N/A	N/A	N/A	R	R
Key control	N/A	N/A	N/A	N/A	R	R
Emission indicator	N/A	N/A	R	R	R (see note 10)	R (see note 10)
Beam attenuator	N/A	N/A	R	R	R	R
Reset	N/A	N/A	N/A	N/A	N/A	R (see note 13)
<b>Performance (specific purpose products)</b>						
Medical	S	S	S	S (see note 8)	S (see note 8)	S (see note 8)
Surveying, leveling, alignment	S	S	S	S	NP	NP
Demonstration	S	S	S	S	S (see note 11)	(see note 11)
<b>Labeling (all laser products)</b>						
Certification & identification	R	R	R	R	R	R
Protective housing	D (see note 5)	D (see note 5)	D (see note 5)	D (see note 5)	D (see note 5)	D (see note 5)
Aperture	N/A	N/A	R	R	R	R
Class warning	N/A	R (see note 6)	R (see note 7)	R (see note 9)	R (see note 12)	R (see note 12)
<b>Information (all laser products)</b>						
User information	R	R	R	R	R	R
Product literature	N/A	R	R	R	R	R
Service information	R	R	R	R	R	R

Abbreviations:

R: Required.

N/A: Not applicable.

S: Requirements: Same as for other products of that Class.  
Also see footnotes.

NP: Not permitted.

D: Depends on level of interior radiation.

Footnotes:

1. Based on highest level accessible during operation.
2. Required wherever & whenever human access to laser radiation above Class I limits is not needed for product to perform its function.
3. Required for protective housings opened during operation or maintenance, if human access thus gained is not always necessary when housing is open.
4. Interlock requirements vary according to Class of internal radiation.
5. Wording depends on level & wavelength of laser radiation within protective housing.

6. Warning statement label.
7. CAUTION logotype.
8. Requires means to measure level of laser radiation intended to irradiate the body.
9. CAUTION if  $2.5 \text{ mW cm}^2$  or less, DANGER if greater than  $2.5 \text{ mW cm}^{-2}$ .
10. Delay required between indication & emission.
11. Variance required for Class IIb or IV demonstration laser products and light shows.
12. DANGER logotype.
13. Required after August 20, 1986.

## Use Precautions

### EN60825-1

Requirements; Sub-clause	Classification				
	Class 1	Class 2	Class 3A	Class 3B*	Class 4
Remote interlock	Not required			Connect to room or door circuits	
Key control	Not required			Remove key when not in use	
Beam attenuator	Not required			When in use prevents inadvertent exposure	
Emission indicator device	Not required			Indicates laser is energized	
Warning signs	Not required			Follow precautions on warning signs	
Beam path	Not required	Terminate beam at end of useful length			
Specular reflection	No requirements			Prevent unintentional reflections	
Eye protection	No requirements		Required if engineering and administrative procedures not practicable and MPE exceeded		
Protective clothing	No requirements			Sometimes required	Specific requirements
Training	No requirements		Required for all operator and maintenance personnel		

\* With respect to the requirements of remote interlock connector, key control, beam attenuator, and emission indicator, Class 3B laser products not exceeding five times the AEL of Class 2 in the wavelength range of 400 nm to 700 nm are to be treated as Class 3A laser products.

**Note:** This table is intended to provide a convenient summary of requirements. See text of this standard for complete precautions.

### ANSI Z136.1:1993 "American National Standard for the Safe Use of Lasers" Control Measures for the Four Laser Classes

Control measures	Classification					
	1	2a	2	3a	3b	4
Engineering Controls	X	X	X	X	X	X
Protective Housing (4.3.1)	X	X	X	X	X	X
Without Protective Housing (4.3.1.1)	LSO (see note 2) shall establish Alternate Controls					
Interlocks on Protective Housing (4.3.2)					X	X
Service Access Panel (4.3.3)					X	X
Key Control (4.3.4)	---	---	---	---	•	X
Viewing Portals (4.3.5.1)	---	---	MPE	MPE	MPE	MPE
Collecting Optics (4.3.5.2)	MPE	MPE	MPE	MPE	MPE	MPE
Totally Open Beam Path (4.3.6.1)	---	---	---	---	X NHZ	X NHZ
Limited Open Beam Path (4.3.6.2)	---	---	---	---	X NHZ	X NHZ
Enclosed Beam Path (4.3.6.3)	None is required if 4.3.1 and 4.3.2 fulfilled					
Remote Interlock Connector (4.3.7)	---	---	---	---	•	X
Beam Stop or Attenuator (4.3.8)	---	---	---	---	•	X
Activation Warning Systems (4.3.9)	---	---	---	---	•	X
Emission Delay (4.3.9.1)	---	---	---	---	---	X
Indoor Laser Controlled Area (4.3.10)	---	---	---	---	X NHZ	X NHZ
Class 3b Laser Controlled Area (4.3.10.1)	---	---	---	---	X	---
Class 4 Laser Controlled Area (4.3.10.2)	---	---	---	---	---	X
Laser Outdoor Controls (4.3.11)	---	---	---	---	X NHZ	X NHZ
Laser in Navigable Airspace (4.3.11.2)	---	---	---	•	•	•

Control measures	Classification					
	MPE	MPE	MPE	MPE	---	---
Temporary Laser Controlled Area (4.3.12)	MPE	MPE	MPE	MPE	---	---
Remote Firing & Monitoring (4.3.13)	---	---	---	---	---	•
Labels (4.3.14 and 4.7)	X	X	X	X	X	X
Area Posting (4.3.15)	---	---	---	•	X NHZ	X NHZ
Administrative & Procedural Controls	1	2a	2	3a	3b	4
Standard Operating Procedures (4.4.1)	---	---	---	---	•	X
Output Emission Limitations (4.4.2)	---	---	---	LSO Determination		
Education and Training (4.4.3)	---	---	•	•	X	X
Authorized Personnel (4.4.4)	---	---	---	---	X	X
Alignment Procedures (4.4.5)	---	---	X	X	X	X
Protective Equipment (4.4.6)	---	---	---	---	•	X
Spectator (4.4.7)	---	---	---	---	•	X
Service Personnel (4.4.8)	MPE	MPE	MPE	MPE	X	X
Demonstration with General Public (4.5.1)	MPE	---	X	X	X	X
Laser Optical Fiber Systems (4.5.2)	MPE	MPE	MPE	MPE	X	X
Laser Robotic Installations (4.5.3)	---	---	---	---	X NHZ	X NHZ
Eye Protection (4.6.2)	---	---	---	---	• MPE	X MPE
Protective Windows (4.6.3)	---	---	---	---	X NHZ	X NHZ
Protective Barriers and Curtains (4.6.4)	---	---	---	---	•	•
Skin Protection (4.6.5)	---	---	---	---	X MPE	X MPE
Other Protective Equipment (4.6.5)	Use may be required					
Warning Signs and Labels (4.7) (Design Requirements)	---	---	•	•	X NHZ	X NHZ
Service and Repairs (4.8)	LSO Determination					
Modification of Laser Systems (4.9)	LSO Determination					

**Note:** 1. LEGEND

- X: Shall
- : Should
- : No requirement
- : Shall if enclosed Class 3b or Class 4
- MPE: Shall if MPE is exceeded
- NHZ: Nominal Hazard Zone analysis required
- : Applicable only to UV and IR Lasers (4.5.1.2)

## 2. LSO: Laser Safety Officer

An individual shall be designated the Laser Safety Officer with the authority and responsibility to monitor and enforce the control of laser hazards, and to effect the knowledgeable evaluation and control of laser hazards. For your reference, see ANSI Z136.1-1993, Section 1.3.

## ■ Laser Product Classifications

### EN

Class	Description
<b>Class 1</b>	Lasers which are safe under reasonably foreseeable conditions of operation.
<b>Class 2</b>	Lasers emitting visible radiation in the wavelength range from 400 nm to 700 nm. Eye protection is normally afforded by aversion responses including the blink reflex.
<b>Class 3A</b>	Lasers which are safe for viewing with the unaided eye. For laser emitting in the wavelength range from 400 nm to 700 nm, protection is afforded by aversion responses including the blink reflex. For other wavelengths the hazard to the unaided eye is no greater than for Class 1. Direct intrabeam viewing of Class 3A lasers with optical aides (e.g., binoculars, telescopes, microscopes) may be hazardous.
<b>Class 3B</b>	Direct intrabeam viewing of these lasers is always hazardous. Viewing diffuse reflections is normally safe (see note).
<b>Class 4</b>	Lasers which are also capable of producing hazardous diffuse reflections. They may cause skin injuries and could also constitute a fire hazard. Their use requires extreme caution.

**Note:** Conditions for safe viewing of diffuse reflections for Class 3B visible lasers are: minimum viewing distance of 13 cm between screen and cornea and a maximum viewing time of 10 s. Other viewing conditions require a comparison of the diffuse reflection exposure with the MPE.

**Comparison of Classifications between FDA and ANSI**

Class	FDA definition	ANSI description
<b>Class I/1</b>	Limits applicable to devices that have emissions in the ultraviolet, visible, and infrared spectra, and limits below which biological hazards have not been established.	A Class 1 laser is considered to be incapable of producing damaging radiation levels during operation and maintenance and is, therefore, exempt from any control measures or other forms of surveillance.
<b>Class IIa/2a</b>	Limits applicable to products whose visible emission does not exceed Class I limits for emission durations of 1,000 seconds or less and are not intended for viewing.	Class 2 lasers are divided into two subclasses, 2 and 2a. A Class 2 laser emits in the visible portion of the spectrum (0.4 to 0.7 μm) and eye protection is normally afforded by the aversion response including the blink reflex.
<b>Class II/2</b>	Limits applicable to products that have emissions in the visible spectrum (400 to 710 nm) for emission durations in excess of 0.25 second, providing that emissions for other durations and/or wavelengths do not exceed the Class I limits. Class II products are considered hazardous for direct long-term ocular exposure.	
<b>Class IIIa/3a</b>	Limits to products that have emissions in the visible spectrum and that have beams where the total collectable radiant power does not exceed 5 milliwatts.	Class 3 lasers are divided into two subclasses, 3a and 3b. A Class 3 laser may be hazardous under direct and specular reflection viewing conditions, but the diffuse reflection is usually not a hazard.
<b>Class IIIb/3b</b>	Limits applicable to devices that emit in the ultraviolet, visible, and infrared spectra. Class IIIb products include laser systems ranging from 5 to 500 milliwatts in the visible spectrum. Class IIIb emission levels are ocular hazards for direct exposure throughout the range of the Class, and skin hazards at the higher levels of the Class.	
<b>Class IV/4</b>	Exceeding the limits of Class IIIb and are a hazard for scattered reflection as well as for direct exposure.	A Class 4 laser is a hazard to the eye or skin from the direct beam and sometimes from a diffuse reflection and also can be fire hazard. Class 4 lasers may also produce laser-generated air contaminants and hazardous plasma radiation.

**Label Indications**

EN



**Note:** Use of controls, adjustments, or procedures other than those specified herein may result in hazardous radiation exposure.  
FDA

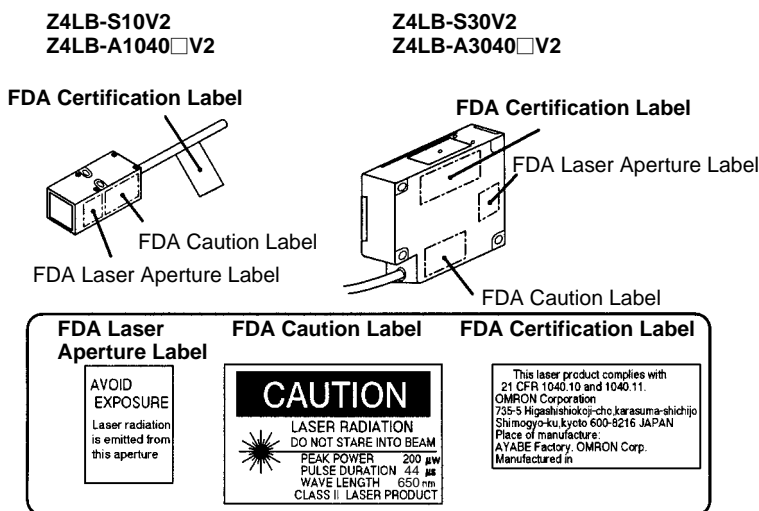

**Note:** Use of controls, adjustments, or procedures other than those specified herein may result in hazardous radiation exposure.



The product has been produced at OMRON Ayabe which obtained ISO9001-approval for its quality system and ISO14001-approval for its environmental management system from international certification bodies.

**ALL DIMENSIONS SHOWN ARE IN MILLIMETERS.**

To convert millimeters into inches, multiply by 0.03937. To convert grams into ounces, multiply by 0.03527.

Cat. No. F051-E1-1A **In the interest of product improvement, specifications are subject to change without notice.**

---

**OMRON Corporation**

Industrial Automation Company

Industrial Sensors Division  
Sensing Devices and Components Division H.Q.  
28th Fl., Crystal Tower Bldg.,  
1-2-27, Shiromi, Chuo-ku,  
Osaka 540-6028 Japan  
Tel: (81)6-6949-6012/Fax: (81)6-6949-6021

Printed in Japan  
0400-1M (1099) Ⓐ