

**Frequency
Inverter**

FR-F 540L EC

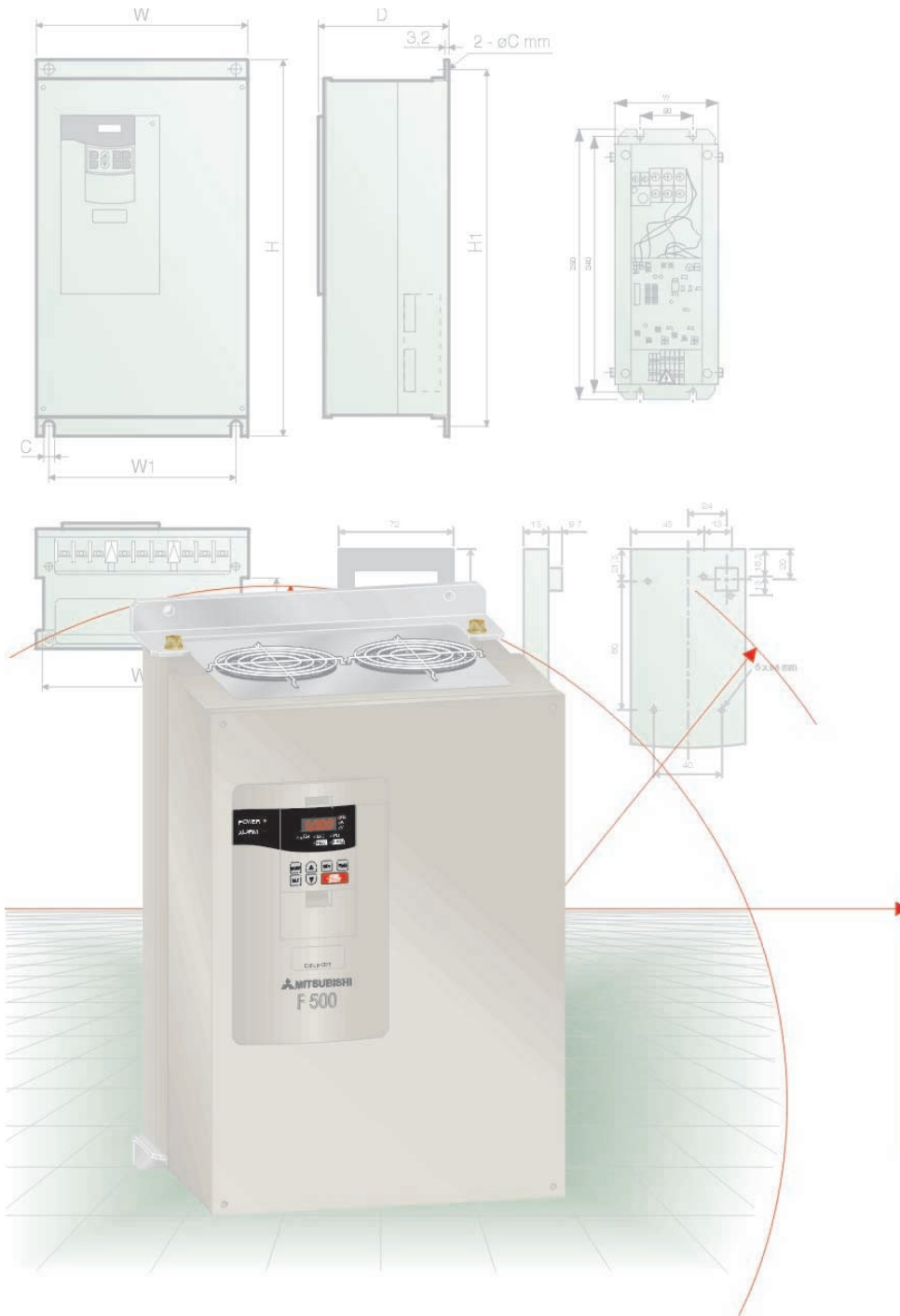

Technical Catalogue

The New Frequency Inverter Series FR-F 540 EC

The Power-Saving Inverter

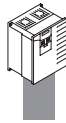

The new FR-F 540L EC frequency inverters are available with outputs between 75 and 530 kW. They are ideal for high-load applications like pumps and ventilator fans.

These units use a 3-phase AC power supply and have an output frequency range from 0.5 – 120 Hz.

Further Publications within the Factory Automation Range

Technical Catalogues

Technical catalogues FR-E 500, FR-A 500 and FR-S 500

Product catalogue for frequency inverters and accessories of the FR-E 500, FR-F 500 and FR-S 500 series

Technical catalogues MELSERVO and Motion Controllers

Product catalogues for MR-J2S series amplifiers, servo motors and motion controllers with SSCNET connection

Technical catalogues PLC and HMI

Product catalogues for programmable logic controllers, operator terminals, software, and accessories of the MELSEC PLC series

Networks Technical Catalogue

Product catalogue for Master and Slave modules as well as accessories for the use of programmable logic controllers and frequency inverters in open networks and MELSEC networks (art. no. 136730)

Additional services

You will find current information on updates, alterations, new items, and technical support on MITSUBISHI ELECTRIC's web pages (www.mitsubishi-automation.com).

The products section of the MITSUBISHI home site includes various documentations of the whole product range by MITSUBISHI ELECTRIC as well as the current version of this catalogue on hand. All manuals and catalogues can be downloaded.

The content is updated daily and to date is provided in German and English.

About this product catalogue

This catalogue is periodically updated due to product range enlargement, technical changes or new or changed features.

Texts, figures and diagrams shown in this product catalogue are intended exclusively for explanation and assistance in planning and ordering the frequency inverter series FR-F 500L EC and the associated accessories. Only the manuals supplied with the devices are relevant for installation, commissioning and handling of the devices and the accessories. The information given in these manuals must be read before installation and commissioning of the devices or software.

Should questions arise with regard to the planning of devices described in this product catalogue, do not hesitate to contact MITSUBISHI ELECTRIC EUROPE B.V. in Ratingen (Germany) or one of its distributors (see cover page).

© MITSUBISHI ELECTRIC EUROPE B.V. 08/2003 (1st edition - version A)

FREQUENCY INVERTER FR-F 540L EC

SYSTEM DESCRIPTION

- ◆ Introduction to the FR-F series 4
- ◆ Energy conservation mode 5
- ◆ Control functions, standards, communications and operation 6
- ◆ Specifications 8
- ◆ Terminal assignment 10



OPERATION

- ◆ Control panel FR-DU04 12
- ◆ Control panel FR-PU04 13



PARAMETERS

- ◆ Overview 15



PROTECTIVE FUNCTIONS

- ◆ Overview of protective functions 19
- ◆ Resetting methods 21

APPLICATIONS

- ◆ Sample applications 22



ACCESSORIES

- ◆ Overview of internal and external options 24
- ◆ Noise filters 26
- ◆ DC reactors 26
- ◆ Brake units 27
- ◆ External brake resistors 27



DIMENSIONS

- ◆ Control panels 28
- ◆ Frequency inverters 29
- ◆ Chokes 31
- ◆ Filters 32
- ◆ Brake resistors 33
- ◆ Brake units 33

APPENDIX

- ◆ Order form 34
- ◆ Index 35

The Frequency Inverter FR-F 540L EC

The FR-F 540L EC is suitable for a very broad spectrum of applications in the high power range. With its excellent power-conservation capabilities it is ideal for pumps, ventilation fans and applications with reduced overload requirements, such as:

- Air conditioning systems, e.g. in building services
- Air extraction systems
- Fans and blowers
- Hydraulics systems
- Compressors
- Sewage and drains systems
- Ground water pumps
- Heat pumps
- Drive systems with a high idling percentage

In addition to their outstanding performance and power delivery these units are also very user-friendly.

The FR-F 540L EC inverters are available with outputs from 75 – 530kW. All the inverters are designed for connection to 3~ 380-480V (50/60Hz) power supplies.

The output frequency ranges from 0.5 to 120 Hz.

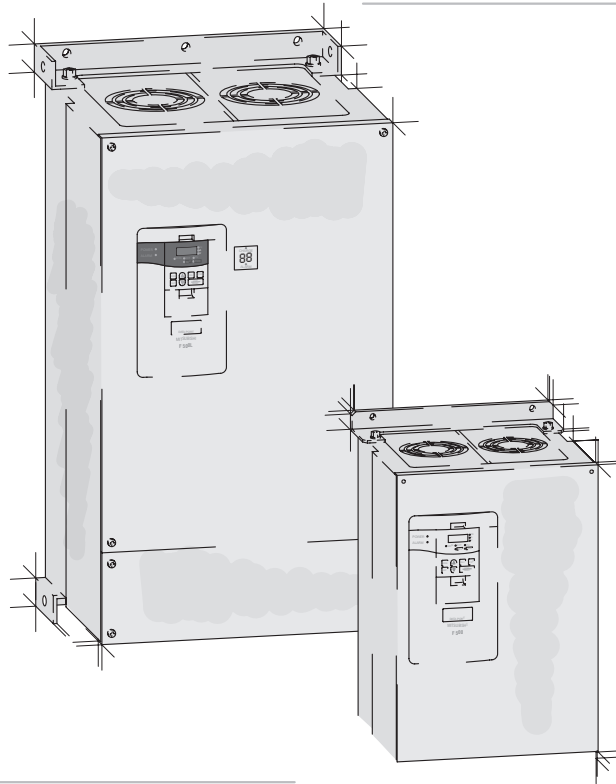

Proven Technology with New, Optimised Capabilities

High-tech processor technology

The general design of the FR-F540 L EC family is based on the successful FR-A 540 (L-G). Just like the FR-A series, the FR-F 540 uses advanced ASIC components, state-of-the-art IGBT power semiconductors and advanced signal processors.

Active current limiting

Tried and tested capabilities like the active current limiting feature have been retained. However, the response characteristics of the current limiting have been further improved to prevent unwanted triggering of the overcurrent protection. Transient current surges like those generated when a motor coasting in reverse is started or when an input contactor is closed will no longer trigger the current limiter.

Optimum excitation control mode

The "optimum excitation control mode" enables additional power savings that are not possible with other types of inverters designed for pump and fan systems.

The graph below shows a typical example of the performance improvement that can be achieved with this control mode.

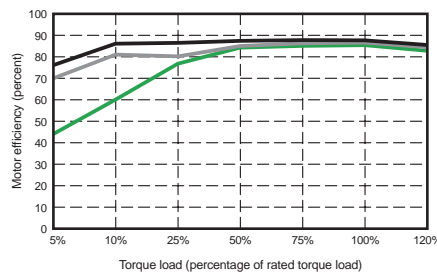

- Optimum excitation control mode
- Standard inverter
- No excitation control

Innovative performance optimisation

The drive characteristics of the FR-F540L-series have been optimised for the special needs of pump and fan applications. These drive systems are characterised by a load torque that increases by the cube of the motor speed (variable curve). However, the units can also be used to power other drive types with reduced loads combined with lower overload demands and no extreme torque requirements at low frequencies – the FR-F540L provides many benefits for such applications. Of course, you can also power standard applications with "constant" curves and maximum overloads of 150 %.

The inverters also include all the following outstanding features:

- Power-saving mode
- Extended PID control
- PID control with multi-motor switching function
- Disable defined frequency ranges
- 2nd parameter set selectable for different load characteristics
- Switch motor to direct mains operation

Intelligent Technology that Cuts Power Consumption

Saving power with Mitsubishi frequency converters

Reducing consumption and optimising the utilisation of our valuable energy resources is one of the greatest global environmental challenges of our age.

Energy conservation mode is a standard feature of the intelligent controller. It dynamically adjusts the voltage to motor requirements, eliminating unnecessary power losses, which helps to further reduce power consumption. Frequency inverters are particularly effective at conserving energy when they are used to control pumps and fans.

The amount of energy conservation (hysteresis) depends on the speed/torque fluctuations. The graph below provides an impressive example of the results of intelligent control in a fan system.

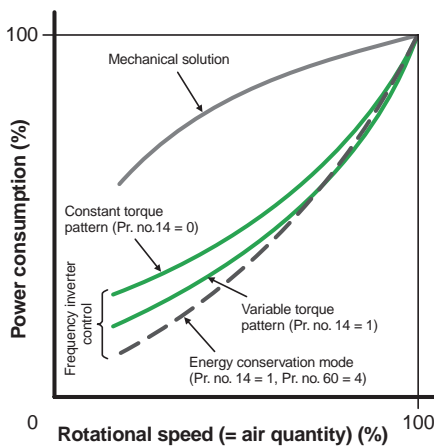

How do frequency inverters conserve energy?

The illustration at the bottom of the page shows a blower system in which the air flow is regulated by controlling the motor with a frequency inverter instead of with a damper on the exhaust side.

The graph below compares the motor power consumption of the frequency inverter and damper solutions. At a flow rate of 60% the curve shows that the frequency inverter system consumes a full 60% less power than the motor with the damper system.

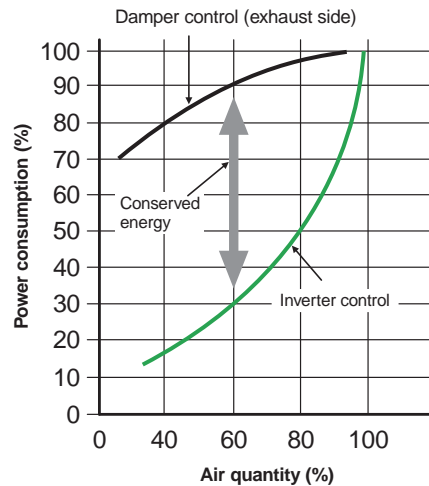

Potential savings

In addition to the ecological benefits frequency inverters can also save a great deal of money by radically cutting power consumption.

Example:

Based on the graph on the left and an electricity price of 14 cents per kWh, the following savings can be achieved with a system using a 75 kW motor:

- **Conventional mechanical solution**
At an air throughput of 60 % the power consumption is 90 %, resulting in the following annual costs:

$$75 \text{ kW} \times 0.9 \times 0.14 \text{ €} \times 24 \text{ h} \times 365 \text{ days} = 82,782 \text{ €}$$

- **Frequency inverter solution**
At an air throughput of 60 % the power consumption is 30 %, resulting in the following annual costs:

$$75 \text{ kW} \times 0.3 \times 0.14 \text{ €} \times 24 \text{ h} \times 365 \text{ days} = 27,594 \text{ €}$$

This means that the inverter solution saves € 55,188 per year compared to the conventional mechanical system!

Clearly, a frequency inverter will pay for itself in a very short time – and one must also remember that the potential savings increase with the power ratings of the motors used.

Application with potential for power savings

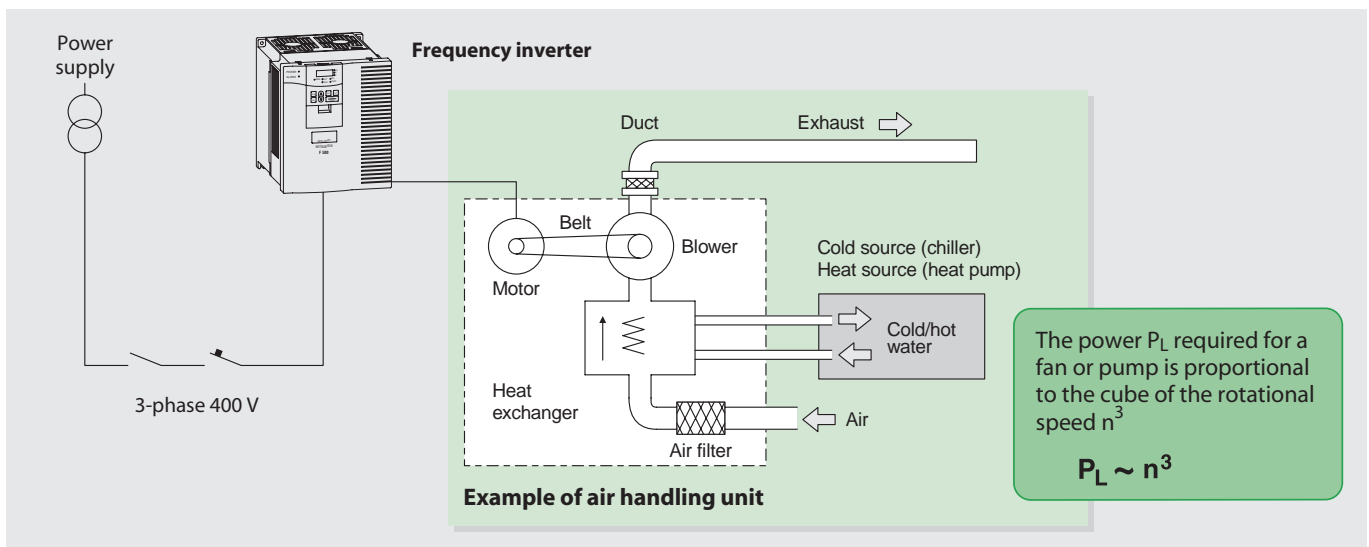

Intelligent Motor Control Functions

Extended PID control

The FR-F500L supports extended PID control. This feature makes it possible to connect the process status signal to the frequency inverter as a voltage signal (0–10 V DC) or a current signal (0/4–20 mA DC) and then use the analog input calibration function of the inverter to compensate minor controller-related fluctuations.

In addition to this the frequency inverter can also control up to four motors successively. This function is programmable; for example, you can program it so that only one motor is frequency-controlled and the others are switched on and off under direct mains power as required, or you can alternate between direct mains power and frequency control for all four motors.

The graph on the right illustrates this multi-motor switching function with a typical example.

When implementing an application like this you must plan the necessary number of magnetic power contactors and the required number of output signal terminals on the inverter. Care must also be taken to ensure that the mains power is never switched to the inverter output.

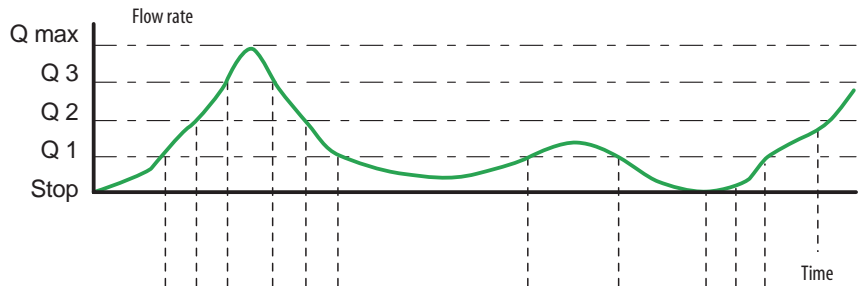

Standard mode

Motor 1 (M1)	●	●	●	●	●	●	●	●	●	●	●
Motor 2 (M2)	—	○	○	○	○	○	—	○	—	—	○
Motor 3 (M3)	—	—	○	○	○	—	—	—	—	—	—
Motor 4 (M4)	—	—	—	○	—	—	—	—	—	—	—

Alternating mode*

Motor 1 (M1)	●	●	●	●	●	●	●	●	●	●	●
Motor 2 (M2)	—	○	○	○	○	○	—	○	—	●	●
Motor 3 (M3)	—	—	○	○	○	—	—	—	—	—	○
Motor 4 (M4)	—	—	—	○	—	—	—	—	—	—	—

Direct mode

Motor 1 (M1)	●	○	○	○	—	—	—	●	●	●	○
Motor 2 (M2)	—	●	○	○	○	—	—	—	—	—	●
Motor 3 (M3)	—	—	●	○	○	○	—	—	—	—	—
Motor 4 (M4)	—	—	—	●	●	●	●	○	—	—	—

- VFD controlled operation
- Conventional operation
- Stop

* After switching the magnetic contactor the motor start sequence switches from M1->M2->M3 to M2->M3->M1

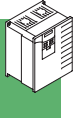

Electromagnetic compatibility

The FR-F 540L EC conforms to the EMC standards of the European Community. To meet the requirements in your application you must install an input EMC filter.

The EMC filters are available for inverters of all performance ranges. Refer to page 24 for further details.

The frequency inverters of the FR-F 540L EC series include a DC link reactor as standard equipment, and the reactor must be used with these models.



World-standard specifications

The units of the FR-A 540(L-G) EC product line are designed to be used world-wide without further effort or certifications.

- World-wide CE, UL, cUL standard compliant
- Selectable sink or source logic. The logic for input and output signals can be freely selected. The result is a flexible and easy customisation of the units to the needs of the world market.
- Extended rated input voltage 3~ 380–480 V; 50 Hz / 60 Hz Tolerance: –15 %; +10 %
- Multiple language parameter unit
- Compatible to several world-wide common communications standards
- MS-Windows compatible world-wide standardised multi-language parameterising software

The FR-F 540L EC therefore is a world product complying with all relevant standards and easily adopting to the according needs of a country.

Communications

For the integration in an automation plant a serial interface RS485 is included as standard equipment. Through this interface up to 32 inverters can be linked up. Open communications with standardised industrial bus systems like Profibus/DP, CANopen (Europe), DeviceNet (USA), and CC-Link (Asia) can be realised easily via optional interface cards. This enables the integration of the inverter in entire automation concepts.

User-friendly Operation

Easy operation via control panel or via software

The **FR-DU04** control panel is included as standard equipment of all inverters. It features a clear and easy operation of the inverter and displays several operational and alarm signals. The integrated copy function makes it possible to read out the entire stored parameter set and transfer it to another frequency inverter, or compare the parameters with the settings in the other inverter. The control panel can also be connected remotely via an extension cable.

The **FR-PU04** control panel is optionally available. It provides a long-life back-light LC-display. Operational data is directly input on the numeric keypad. Eight different selectable languages are supported on the display. This control panel too can be installed either directly on the inverter or connected remotely with a cable. You can define user groups with which you can activate or change sets of user-definable parameters for specific applications.

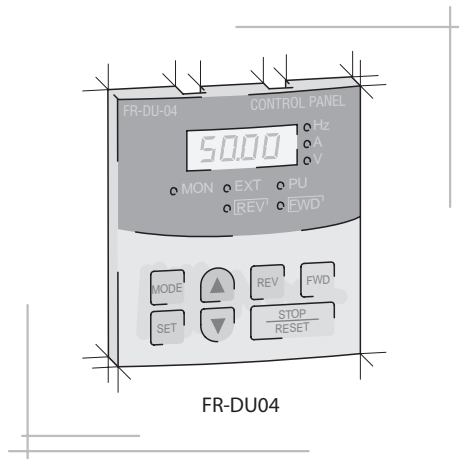

FR-DU04

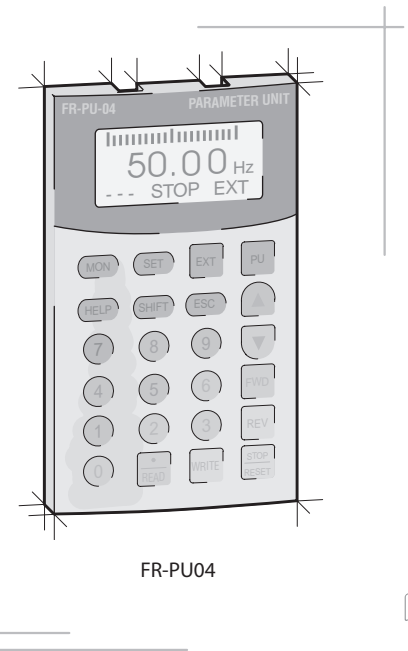

FR-PU04

The integrated copy function transfers the entire parameter settings to other inverters and thus shortens the initialisation time significantly.

In addition to control panel operation the frequency inverter can also be connected to a standard PC via an RS-485 port and operated from the PC with the optional VFD setup software package. Version 2.4 and above of this package run under Windows® 95, 98, Me and XP and also

under Windows® NT and 2000. Using this software you can configure, operate and monitor multiple frequency inverters in a network or directly from a single PC or notebook computer.



User-friendly Maintenance and Handling

Easy access to cooling fans

The easily accessible cooling fans can be replaced quickly and easily if required. The lifetime of the cooling fans can be extended significantly through a selective ON/OFF control specified by parameter 244.

Easy installation and maintenance

Simple installation and removal of the control terminal block makes installation and maintenance easier.

Easy transfer of parameter settings via control panel

Once the parameter settings are specified, they can be transferred from one inverter to the other via the control panel.

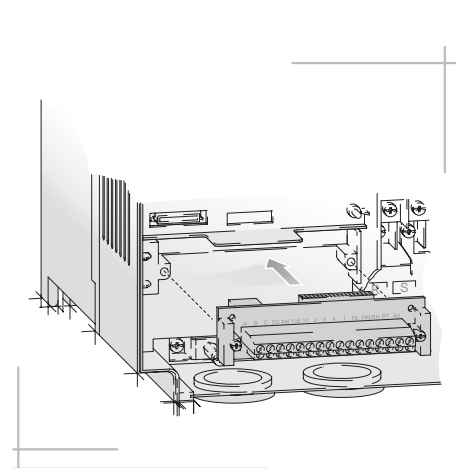
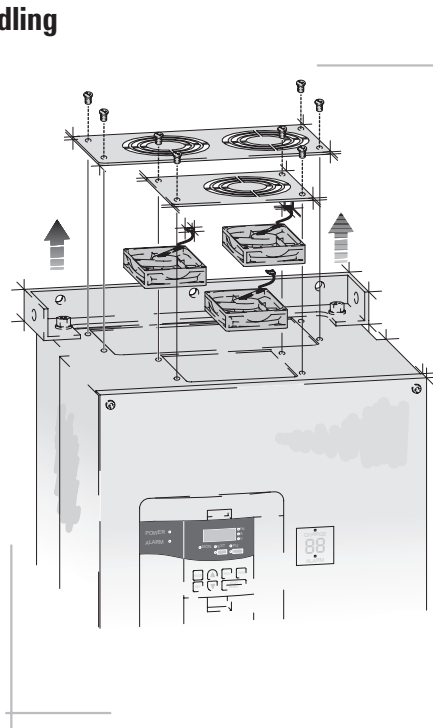

Specifications FR-F 540L EC

Product line		FR-F 540L											
		75 k	90k	110 k	132 k	160 k	185 k	220 k	280 k	375 k	450 k	530 k	
Output	Rated motor capacity [kW] ^①	120 % overload capacity ^①	75	90	132	160	185	220	250	315	400	530	530
		150 % overload capacity ^②	75	90	110	132	160	185	220	280	375	450	530
	Rated current [A]	120 % overload capacity ^①	144	180	260	302	360	432	477	610	750	1010	1010
		150 % overload capacity ^②	144	180	216	260	302	360	432	547	722	866	1010
	Rated output capacity [kVA]	120 % overload capacity ^①	110	137	198	230	274	329	417	464	571	770	770
		150 % overload capacity ^②	110	137	165	198	230	274	329	417	550	660	770
	Overload current rating ^① ^②		120 % of rated motor capacity for 0,5 s; 110 % for 1 min. (max. ambient temperature = 40 °C); typical e.g. for pumps and fans										
			150 % of rated motor capacity for 0,5 s; 120 % for 1 min. (max. ambient temperature = 50 °C); typical e.g. for conveyor belts/centrifuges										
	Voltage ^③		3-phase, 0 V up to power supply voltage ^⑤										
	Frequency range		0,5–120 Hz										
Control method		High carrier frequency PWM control (V/F control), optimum excitation control											
Modulation control		Sine evaluated PWM, Soft PWM											
Carrier frequency		0.7 kHz / 1 kHz / 2.5 kHz (user adjustable)											
Input	Power supply voltage	3-phase, 380–480 V AC, 15 % / +10 %											
	Input voltage range	323–528 V AC at 50 / 60 Hz											
	Power supply frequency	50 / 60 Hz ± 5 %											
	Rated input capacity [kVA] ^④	120 % overload capacity ^①	110	137	198	230	274	329	364	464	571	770	770
150 % overload capacity ^②		110	137	165	198	230	274	329	417	550	660	770	
Control specifications	Frequency setting values	Analog input	0.015 Hz / 50 Hz (connecting terminal 2: 12 bits / 0–10 V; 11 bits / 0–5 V, connecting terminal 1: 12 bits / -10–+10 V; 11 bits / -5–+5 V)										
		Digital input	0.01 Hz										
	Frequency precision	±0.2 % of max. output frequency (temperature range 25 °C±10 °C) during analog input; ±0.01 % of max. output frequency during digital input											
	Voltage / frequency characteristics	Base frequency adjustable from 0 to 120 Hz; constant torque or variable torque selectable; optional flexible 5-point V/f characteristics											
	Acceleration / deceleration time	0; 0.1 to 3600 s individual settings											
	Acceleration / deceleration characteristics	Linear or S-form course, user selectable											
	DC braking	Braking time and braking moment adjustable; Operating frequency: 0–120 Hz, operating time: 0–10 s, voltage: 0–30 % (adjustable externally)											
	Torque boost	Manual and automatic torque boost											
Stall prevention	Response threshold 0–150 %, user adjustable, also via analog input												
Motor protection	Electronic motor protection relay (rated current user adjustable)												
Control signals for operation	Frequency setting values	Analog input	0–5 V DC, 0–10 V DC, 0–±10 V DC, 0/4–20 mA										
		Digital input	From control panel or optional circuit board										
	Starting signal	Forward and reverse rotation, start signal automatic self-holding input (3-wire input) can be selected.											
	Multi-speed selection	Up to 7 speeds can be selected. (Each speed can be set between 0 and 120 Hz, running speed can be changed during operation from the control unit (FR-DU04/FR-PU04))											
	2nd/3rd acceleration / deceleration time	0 – 3600 seconds (acceleration and deceleration time can be set individually)											
	JOG operation	Jog operation via control panel or special JOG terminal											
	Current input selection	Frequency setting via current input signal 0/4 to 20 mA DC											
	Automatic restart	Selection of whether automatic restart is made or not after an instantaneous power failure											
	External thermal relay	Thermal relay contact input when the thermal relay provided externally is used to stop the inverter											
	MT-HC connection	Inverter operation enable input and instantaneous power failure detection input											
	External DC dynamic brake	External input for DC dynamic braking start											
	PID control valid	Selection for exercising PID control											
	PU <-> external operation	External selection between PU and external operation											
	PU operation external interlock	External interlock switch-over of PU operation											
Output stop	Instantaneous shut-off of inverter output (frequency, voltage)												
Error message reset	Alarm retained at the activation of protective function is reset												

Product line		FR-F 540L											
		75 k	90 k	110 k	132 k	160 k	185 k	220 k	280 k	375 k	450 k	530 k	
Control signals for operation	Output signals	Operation state	5 different signals can be selected from inverter running, up to frequency, instantaneous power failure (undervoltage), frequency detection, second frequency detection, during PU operation, overload alarm, electronic overcurrent protection pre-alarm, zero current detection, PID lower limit, PID upper limit, PID forward/reverse rotation, commercial power supply-inverter switch-over MC1, 2, 3, operation ready, fan fault and fin overheat pre-alarm minor fault. Open collector output.										
		Alarm functions	Relay output ... contactor (230 V AC / 0.3 A , 30 V DC/ 0.3 A) Open collector output ... error message through alarm code (4 bits)										
		Analog signal or pulse train	One of the following output types can be selected: Output frequency, motor current (constant or peak value), output voltage, frequency setting value, motor speed, converter output voltage (constant or peak value), electronic thermal relay load rate, input power, output power, load meter, motor excitation current and reference voltage output. Pulse train output (1440 Hz / full scale), or analog output (0 to 10 VDC).										
Display options	Displayed on control panel (FR-PU04/FR-DU04)	Operating state	Output frequency, motor current (constant or peak value), output voltage, frequency setting value, motor speed, overload, converter output voltage (constant or peak value), electronic thermal relay load rate, input power, output power, load meter, cumulative power ON time, current operation time, cumulative power, regenerative brake duty, and motor load rate.										
		Alarm display	Error details are displayed after a protective function is activated. Up to 8 error codes can be stored.										
	Additional displays on control panel FR-PU04	Operating state	Signal status of input and output terminals, indication of installed options, indication of terminal assignment state.										
		Alarm display	Output voltage, output current, output frequency, cumulative power ON time before activation of protective function.										
		Interactive operating guide	Interactive guide for operation and troubleshooting via help function.										
Protection	Functions	Overcurrent cutoff (during acceleration, deceleration, constant speed), regenerative overvoltage cutoff, undervoltage, instantaneous power failure, overload cutoff (electronic thermal relay), ground fault overcurrent, output short circuit, overheating of main circuit, stall prevention, overload warning, fan overheating, fan error, option error, parameter error, PU connection error, retry count exceeded, output phase error, CPU error, 24 V DC power output short circuit, operation panel power supply short circuit; output of group error message via relay contact (220 V AC / 0.3 A; 30 V DC / 0.3 A)											
	Protection	IP 00											
Others	Cooling	Fan-cooling											
	Power loss [kW]	120 % overload capacity ①	2.25	2.75	4.12	4.80	5.55	6.75	7.50	9.45	12.0	10.6	10.6
		150 % overload capacity ②	2.25	2.75	3.375	4.12	4.80	5.55	6.75	8.59	11.25	9.0	10.6
	Inverter weight [kg]	41	57	66	66	68	120	120	220	235	560	560	
Choke weight [kg]	14	18	19	22	22	29	36	48	57	100	100		
Order information		Art. no.	141045	141046	141047	141048	141049	141050	141051	141052	141053	142587	142588

- ① The performance values of the rated motor capacity are based on a 400 V motor voltage. At 120 % rating a maximum ambient temperature of 40 °C is allowed.
- ② The overload capacity indicated in % is the ratio of the overload current to the inverter's rated current. For repeated duty, allow time for the inverter and motor to return to or below the temperatures under 100% load.
- ③ The maximum output voltage cannot exceed the power supply voltage. The maximum output voltage may be set as desired below the power supply voltage.
- ④ The power supply capacity changes with the values of the power supply side inverter impedances (including those of the input reactor and cables).
- ⑤ It is not possible to connect 1-phase motors.

General Operating Conditions

Item	Specifications
Ambient temperature in operation	-10 °C to +50 °C (non-freezing) For selection of the load characteristics with a 120 % overload rating the max. temperature is 40 °C.
Storage temperature	-20 – +65 °C
Ambient humidity	Max. 90 % RH (non-condensing)
Altitude	Max. 1000 m above NN
Protection rating	Up to 22kW: IP 20 / from 30 kW: IP00
Shock resistance	10 G (3 times each in 3 directions)
Vibration resistance	2 G: resistance to vibrations from 10 to 55 Hz for 2 hours along all 3 axes
Ambience conditions	For indoor use only, avoid environments containing corrosive gases, install in a dust-free location.
Certifications	UL / CSA / CE / EN

Block Diagram

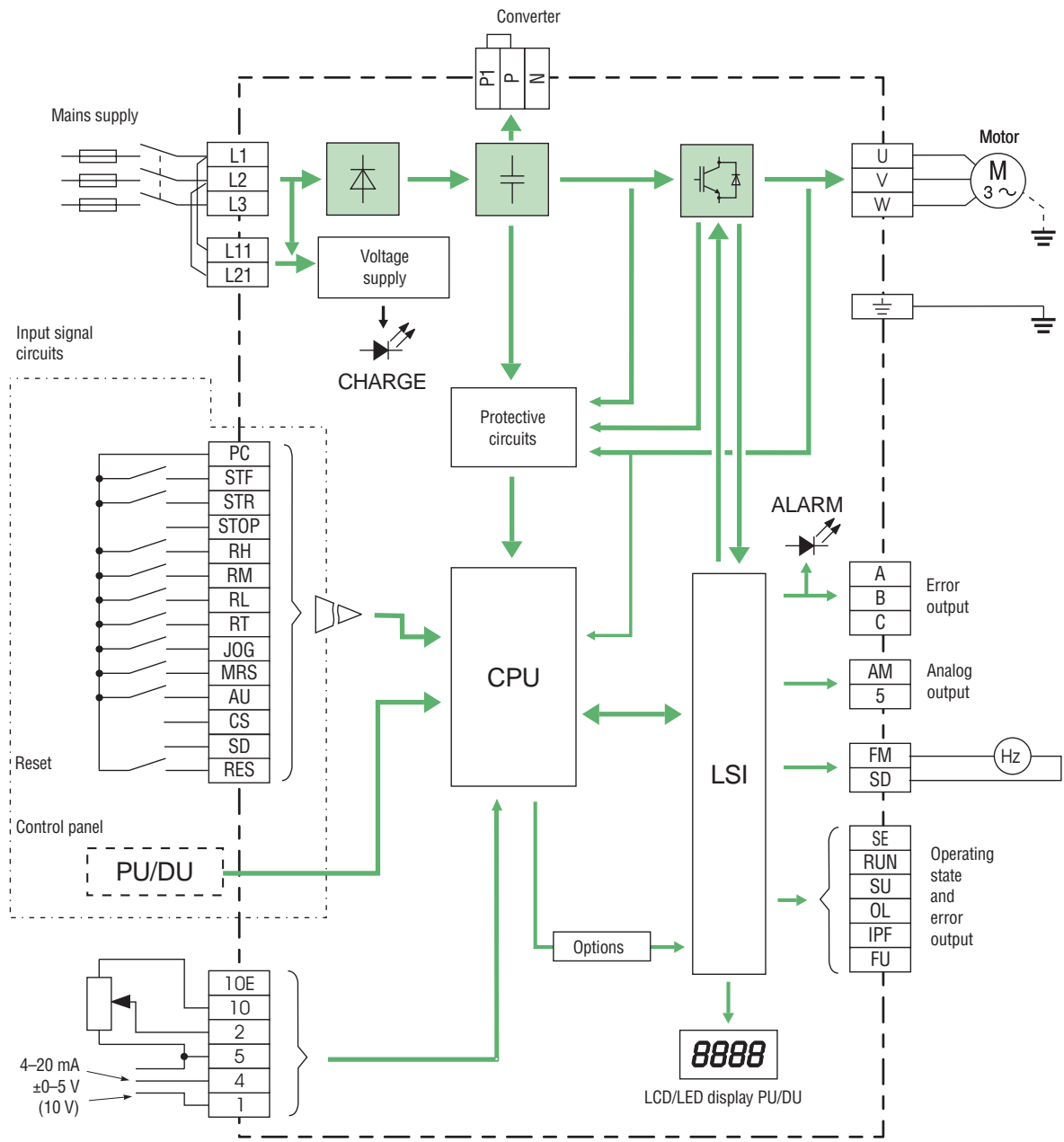

Terminal Assignment of Main Circuit Terminals

Function	Terminal	Designation	Description
Main circuit connection	L1, L2, L3	Mains supply connection	Mains power supply of the inverter (380–480 V AC, 50/60 Hz)
	P, N	External brake unit connection	An optional external brake resistor can be connected to the terminals P and N (up to 375 k) or you can connect the optional high power factor converter (MT-HC) or the power regenerative converter (MT-RC).
	P1, P (P0, P1)	Converter choke coil connection	An optional choke coil can be connected to the terminals P1 and P (up to 375 k) or P0 and P1 (450 k and 530 k). For all FR-F 540L inverters the supplied choke coil has to be installed to the mentioned terminals.
	U, V, W	Motor connection	Voltage output of the inverter (3-phase, 0 V up to power supply voltage, 0.5–120 Hz)
	L11, L21	Control circuit mains supply connection	External power supply input for a separate supply of the control circuit
	⏏	PE	Protective earth connection of inverter

Terminal Assignment of Signal Terminals

Function	Terminal	Terminal name	Description
Control connection	STF	Forward rotation start	The motor rotates forward, if a signal is applied to terminal STF
	STR	Reverse rotation start	The motor rotates reverse, if a signal is applied to terminal STR
	STOP	Start self-retaining selection	The start signals are self-retaining, if a signal is applied to terminal STOP
	RH, RM, RL	Multi-speed selection	Preset of 7 different output frequencies
	JOG	JOG mode selection	The JOG mode is selected, if a signal is applied to terminal JOG (factory setting). The inverters FR-A 540L-G 375 k and 450 k are not equipped with a JOG terminal. The start signals STF and STR determine the rotation direction.
	RT	Second parameter settings	A second set of parameter settings is selected, if a signal is applied to terminal RT.
	MRS	Output stop	The inverter lock stops the output frequency without regard to the delay time. By changing a parameter the pulsed voltage of the DC braking is output as long as the inverter lock is active.
	RES	RESET input	An activated protective circuit is reset, if a signal is applied to the terminal RES ($t > 0,1$ s).
	AU	Current input selection	Only, if the AU signal is ON, the inverter can be operated with the 4–20 mA frequency setting signal.
	CS	Automatic restart after power failure selection	The inverter restarts automatically after a power failure, if a signal is applied to the terminal CS.
Common	SD	Common sink for contact input/reference potential	A determined control function is activated, if the corresponding terminal is connected to the terminal SD. The SD terminal is isolated from the digital circuits via optocouplers. Reference potential for the pulse output FM. The terminal is isolated from the reference potential of the control circuit. Common reference potential for 24 V DC/0.1 A output (PC terminal).
	PC	24 V DC output	24 V DC/0.1 A output. Internal power supply source logic.
Setting value specification	10 E	Voltage output for potentiometer	Output voltage 10 V DC. Max. output current 10 mA. Recommended potentiometer: 1 k Ω , 2 W linear
	10		Output voltage 5 V DC. Max. output current 10 mA. Recommended potentiometer: 1 k Ω , 2 W linear
	2	Input for frequency setting value signal	The voltage setting value 0–5 (10) V is applied to this terminal. The voltage range is preset to 0–5 V. The input resistance is 10 k Ω .
	5	Reference point for frequency setting value signal	Terminal 5 is the reference point for all analog setting values and for the analog output signal AM. The terminal is not isolated from the reference potential of the control circuit and must not be earthed .
	1	Auxiliary input for frequency setting value signal 0– \pm 5 (10) V DC	An additional voltage setting value signal of 0– \pm 5 (10) V DC can be applied to terminal 1. The voltage range is preset to 0– \pm 10 V DC. The input resistance is 10 k Ω .
	4	Input for current setting value signal DC 4–20 mA	The current setting value signal (DC 0/4–20 mA) is applied to this terminal. The input resistance is 250 Ω .
Signal outputs	A, B, C	Potential free alarm output	The alarm is output via relay contacts. The block diagram shows the normal operation and voltage free status. If the protective function is activated, the relay picks up. The maximum contact load is 200 V AC / 0,3 A or 30 V DC / 0,3 A.
	RUN	Signal output for motor operation	The output is switched low, if the inverter output frequency is equal to or higher than the starting frequency. The output is switched high, if no frequency is output or the DC brake is in operation.
	SU	Signal output for frequency setting value / current value comparison	The SU output supports a monitoring of frequency setting value and frequency current value. The output is switched low, once the frequency current value (output frequency of the inverter) approaches the frequency setting value (determined by the setting value signal) within a preset range of tolerance.
	IPF	Signal output for instantaneous power failure	The output is switched low for a temporary power failure within a range of $15 \text{ ms} \leq t_{IPF} \leq 100 \text{ ms}$ or for under voltage.
	OL	Signal output for overload alarm	The OL is switched low, if the output current of the inverter exceeds the current limit preset in parameter 22 and the stall prevention is activated. If the output current of the inverter falls below the current limit preset in parameter 22, the signal at the OL output is switched high.
	FU	Signal output for monitoring output frequency	The output is switched low once the output frequency exceeds a value preset in parameter 42 (or 43). Otherwise the FU output is switched high.
	SE	Reference potential for signal outputs	Reference potential for the signals RUN, SU, OL, IPF, and FU. This terminal is isolated from the reference potential of the control circuit P24.
	FM	Pulse output	One of 16 monitoring functions can be selected, e.g. external frequency output. FM and AM output can be used simultaneously. The functions are determined by parameters. Either a moving coil gauge (measuring range: 1 mA) or a pulse counter with an initial setting of 1440 pulses/s at 60 Hz output frequency (internal resistance of load min. 10 k Ω).
	AM	Analog output	One of 16 monitoring functions can be selected, e.g. external frequency output. FM and AM output can be used simultaneously. The functions are determined by parameters. A DC voltmeter can be connected. The max. output voltage is 10 V.
Interface	—	Connection of control panel (RS485)	Communications via RS485 I/O standard: RS485, Multi-Drop operation, max. 19200 Baud



Control Panel FR-DU04 (Standard)

The control panel FR-DU04 is the standard control panel of the inverter FR-F 540L EC and is included as standard equipment.

The control panel supports the input and display of several control variables (parameters) and a monitoring and output of current operational data. The data is displayed on a 4-digit LED display.

Besides a display and setting of parameters all operating states of the inverter and motor can be monitored. Faults are indicated by error codes.

The control panel can alternatively be attached directly on the inverter or via cable connection mounted remotely, e.g. in a control cabinet.

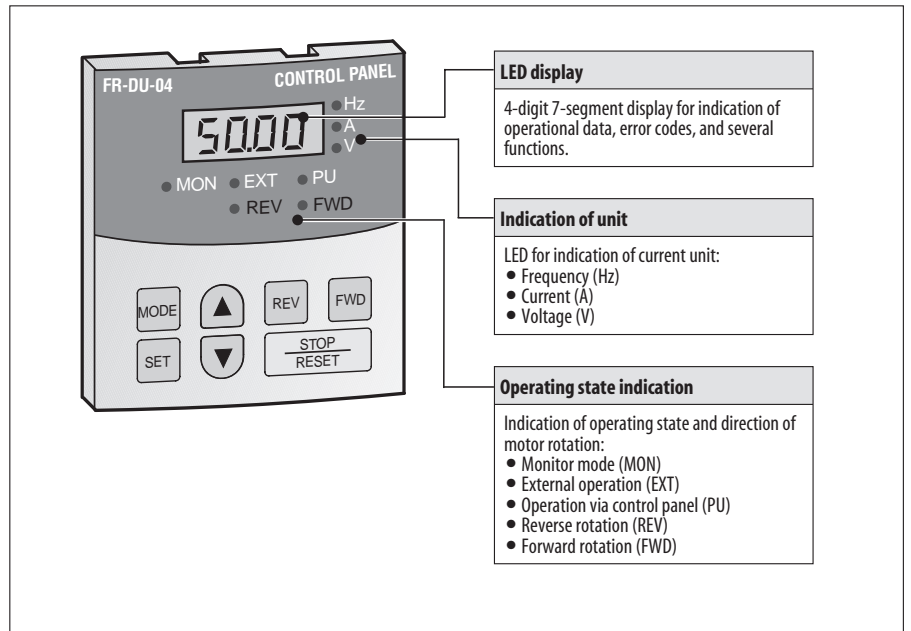

Menu Guide to the Control Panel FR-DU04

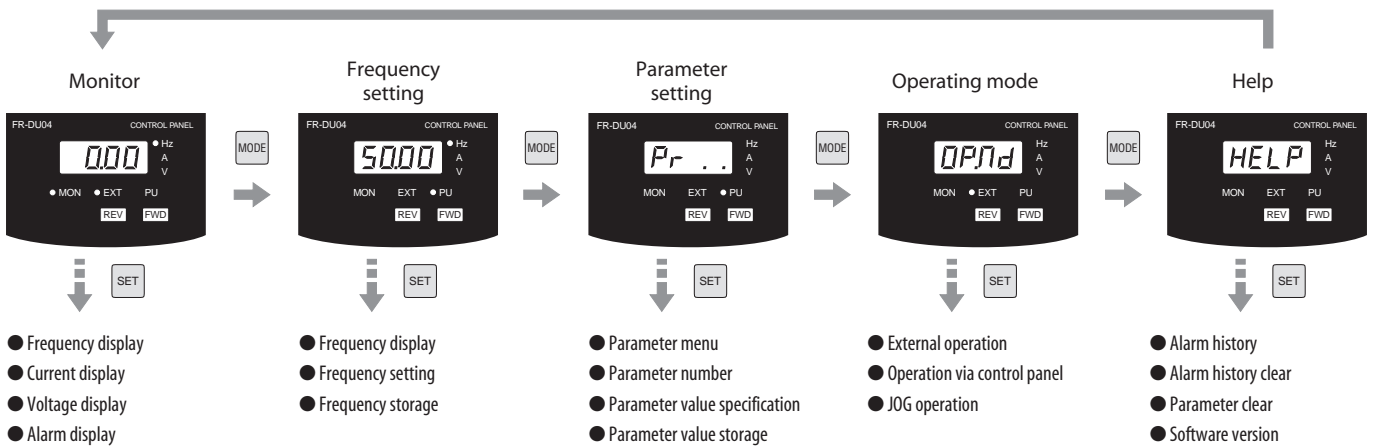

Copying parameters

Via the control panel parameters can be transferred from one inverter to another. For that purpose first read out the parameter settings from the source inverter, then connect the control panel to the destination inverter and transfer the parameters. Initialising and setting times are reduced significantly that way.

The example besides illustrates the procedure of copying parameters via the control panel FR-DU04.

① Press the MODE key twice and the ▼ key twice

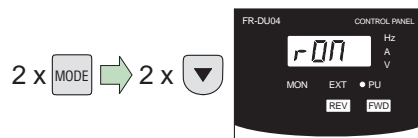

② Press and hold the SET key for 1.5 s, to read all parameter values



③ Press the ▲ key, then press and hold the SET key for 1.5 s, to write all values to the destination inverter



④ Press the ▲ key, then press and hold the SET key for 1.5 s, to verify values



Control Panel FR-PU04 (Optional)

The control panel FR-PU04 with extended functions is available as optional accessory. This control panel provides a 10-key keypad for a direct entering of numerical values. A 4-row LC display returns operational data, parameter names or status and error messages in uncoded text. The control panel displays text in the following selectable languages: English, German, French, Spanish, Swedish, Italian, Finnish, and Japanese.

In addition to the functions of the standard control panel the FR-PU04 displays and monitors 21 different values and states in total.

The control unit FR-PU04 is used instead of the standard control unit FR-DU04 and can be replaced by this after use.

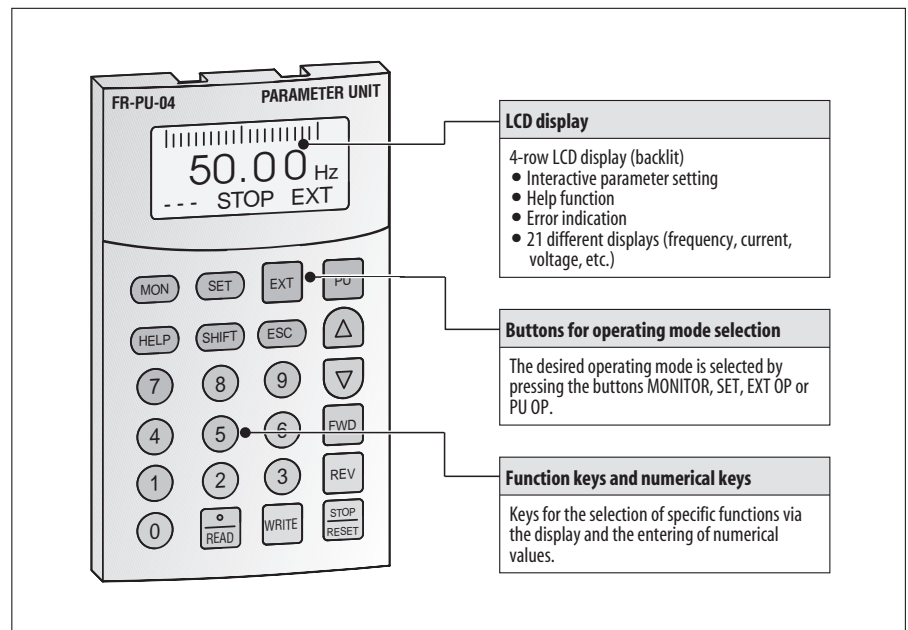

Menu Guide to the Control Panel FR-PU04

Displaying the parameter list

Press the SET key to enter the parameter setting menu. Then press the HELP key to display the parameter lists. After pressing the READ key, the according parameter value will be read in.

Copying parameters

Press the SET key and then the ▲ key to enter the copy mode. Now you find three choices:

- Press the READ key to read out all parameters from the inverter.
- Press the WRITE key to write parameters to the inverter.
- Press the ▼ key to verify the values stored in the control panel and the inverter.

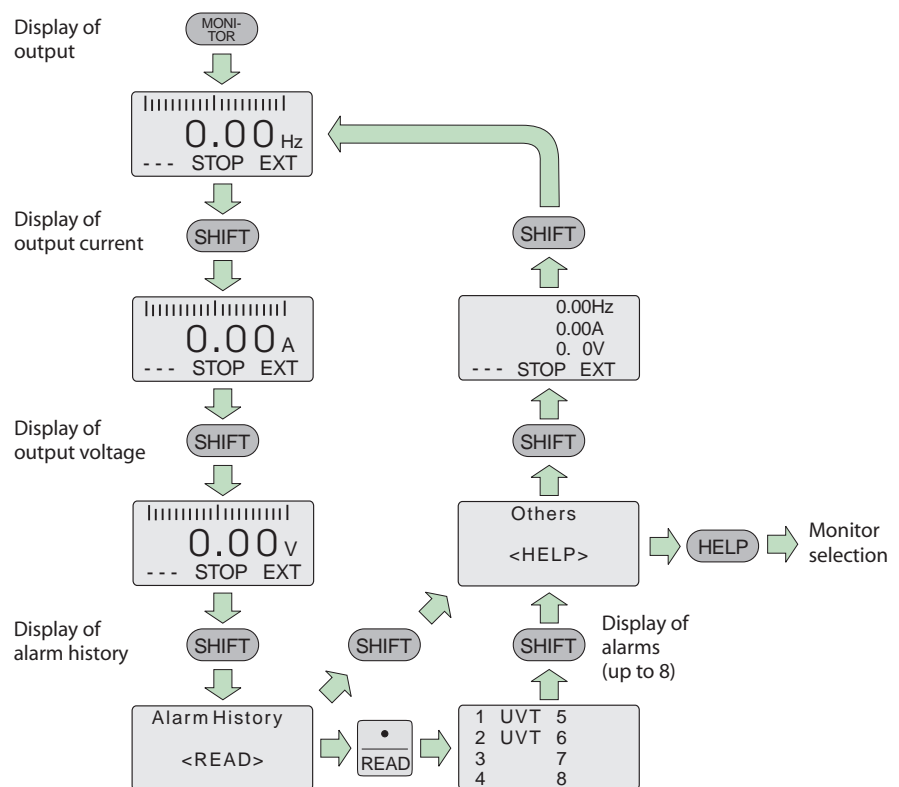

Operating Modes

The inverter can alternatively be operated via external signals or directly via the control panels FR-DU04 or FR-PU04.

The operating mode on the control panel FR-DU04 is selected in the operating mode menu or on the control panel FR-PU04 by pressing the EXT OP key for external signal operation and PU OP for control panel operation.

Sample connection

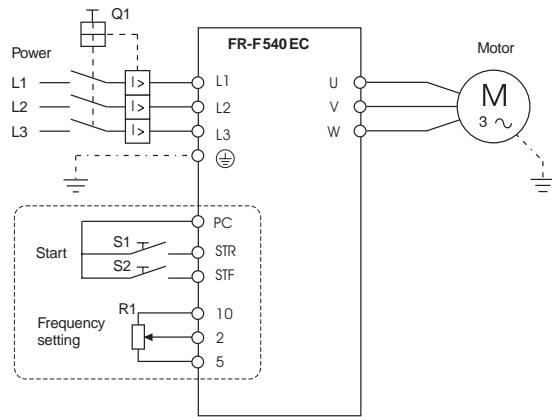

These connections are required for combined operation or operation by external signals.

Operation from the control panel

The direction of rotation and frequency setting of the inverter are controlled from the control panel.

The setting of the output frequency is increased or decreased via the ▲ and ▼ keys.

① Press the MODE key



② Set frequency with SET key



③ Start motor



or

④ Stop motor



Operation by external signals

The direction of rotation and frequency setting of the inverter are controlled by external signals. The following figure shows the display on the control panel FR-DU04 for forward rotation of the motor and a frequency of 50 Hz.



Combined operation

In addition to the operation by external signals and the operation from the control panel (FR-DU04 / FR-PU04) the inverter can be operated in combined operation mode.





- Setting value preset from the control panel and external starting signal.
- External setting value signal and starting signal from the control panel.

Parameter Overview

Function	Parameter	Meaning	Setting range	Default setting	
Basic parameters	0	Torque boost (manual)	0–30 %	1 %	
	1	Maximum output frequency	0–120 Hz	60 Hz	
	2	Minimum output frequency	0–120 Hz	0 Hz	
	3	V/f characteristics (base frequency)	0–120 Hz	50 Hz	
	4	1. Multispeed (high) preset - RH ^②	0–120 Hz	60 Hz	
	5	2. Multispeed (high) preset - RM ^②	0–120 Hz	30 Hz	
	6	3. Multispeed (high) preset - RL ^②	0–120 Hz	10 Hz	
	7	Acceleration time	0–360 s / 0–3600 s	15 s	
	8	Deceleration time	0–360 s / 0–3600 s	30 s	
Parameters for standard drive operation	9	Electronic thermal overload relay (motor protection)	0–3600 A	Rated current	
	10	DC injection brake (initial frequency)	0–120 Hz / 9999	3 Hz	
	11	DC injection brake (operation time)	0–10 s / 8888	0.5 s	
	12	DC injection brake (voltage)	0–30 %	1 %	
	13	Starting frequency	0–60 Hz	0.5 Hz	
	14	Selection of load pattern	0 / 1	1	
	15	JOG frequency	0–120 Hz	5 Hz	
	16	JOG acceleration and deceleration time	0–360 s / 0–3600 s	0.5 s	
	17	MRS input selection	0, 2	0	
	19	Maximum output voltage	0–1000 V / 8888 / 9999	8888	
	20	Acceleration / deceleration reference frequency	1–120 Hz	50 Hz	
	21	Acceleration / deceleration time increments	0 / 1	0	
	22	Stall prevention operation level ^⑦	0–150 % / 9999	120 %	
	23	Stall prevention operation at double speed	0–200 % / 9999	9999	
	24	Multispeed preset (speed 4) ^⑦	0–120 Hz / 9999	9999	
	25	Multispeed preset (speed 5) ^⑦	0–120 Hz / 9999	9999	
	26	Multispeed preset (speed 6) ^⑦	0–120 Hz / 9999	9999	
	27	Multispeed preset (speed 7) ^⑦	0–120 Hz / 9999	9999	
	28	Multi-speed input compensation	0 / 1	0	
	29	Acceleration / deceleration pattern	0 / 1 / 2 / 3	0	
	30	Regenerative function selection	0 / 2	0	
	31	Frequency jump 1A	0–120 Hz / 9999	9999	
	32	Frequency jump 1B	0–120 Hz / 9999	9999	
	33	Frequency jump 2A	0–120 Hz / 9999	9999	
	34	Frequency jump 2B	0–120 Hz / 9999	9999	
	35	Frequency jump 3A	0–120 Hz / 9999	9999	
	36	Frequency jump 3B	0–120 Hz / 9999	9999	
	37	Speed display	0 / 1–9998	0	
	38	Automatic torque boost	0–200 %	0	
	39	Automatic torque boost operation starting current	0–3600 A	0	
	Settings of control outputs	41	Setting value / current value comparison (SU output)	0–100 %	10 %
		42	Output frequency monitoring (FU output)	0–120 Hz	6 Hz
		43	Output frequency monitoring / reverse rotation	0–120 Hz / 9999	9999
	2nd parameter settings	44	2. Acceleration / deceleration time	0–360 s / 0–3600 s	5 s
		45	2. Deceleration time	0–360 s / 0–3600 s / 9999	9999
		46	2. Manual torque boost	0–30 % / 9999	9999
		47	2. V/f characteristics (base frequency)	0–120 Hz / 9999	9999
		48	2. Stall prevention operation current	0–150 %	120 %
		49	2. Stall prevention operation frequency	0–120 Hz / 9999	0 Hz
50		2. Output frequency monitoring	0–120 Hz	30 Hz	

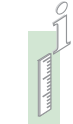

PARAMETERS

Function	Parameter	Meaning	Setting range	Default setting
 Display functions	52	LCD main display on control panel ②	0 / 5 / 6 / 8 / 10–14 / 17 / 20 / 23 / 24 / 25 / 100	0
	53	Bar graph in LCD display ②	0–3 / 5 / 6 / 8 / 10–14 / 17	1
	54	FM terminal function selection ②	1–3 / 5 / 6 / 8 / 10–14 / 17 / 21	1
	55	Frequency monitoring reference ②	0–120 Hz	50 Hz
	56	External current monitoring reference ②	0–3600 A	Rated current
Restart	57	Restart coasting time after power failure	0–30 s / 9999	9999
	58	Restart cushion time before automatic synchronisation	0–60 s	1 s
Aux. functions	59	Selection of digital motor potentiometer	0 / 1 / 2	0
 Operation settings	60	Intelligent mode selection	0 / 3 / 4 / 9	0
	61	Rated current for intelligent mode	0–3600 A / 9999	9999
	62	Current limit for intelligent mode (acceleration)	0–150 % / 9999	9999
	63	Current limit for intelligent mode (deceleration)	0–150 % / 9999	9999
	65	Selection of protective function for automatic restart	0–5	0
	66	Starting frequency for stall prevention at boost frequency	0–120 Hz	50 Hz
	67	Number of restart retries	0–10 / 101–110	0
	68	Waiting time for automatic restart retry	0–10 s	1 s
	69	Counting of automatic restart retries	0	0
	70	Special regenerative brake duty	0–100 %	0 %
	71	Applied motor	0 / 1 / 2	0
	72	PWM frequency selection ②	0 / 1 / 2	1
	73	Specification of setting value input data	0–5 / 10–15	1
	74	Setting value signal filter	0–8	1
	75	Reset condition / connection error / stop ②	0–3 / 14–17	14
	76	Coded alarm output	0 / 1 / 2	0
	77	Write protection for parameters ②	0 / 1 / 2	0
	78	Prevention of reverse rotation	0 / 1 / 2	0
	79	Operation mode selection	0–4 / 6–8	0
	 VF 5 points adjustable	100	V/f1 frequency ①	0–120 Hz / 9999
101		V/f1 voltage ①	0–1000 V	0
102		V/f2 frequency ①	0–120 Hz / 9999	9999
103		V/f2 voltage ①	0–1000 V	0
104		V/f3 frequency ①	0–120 Hz / 9999	9999
105		V/f3 voltage ①	0–1000 V	0
106		V/f4 frequency ①	0–120 Hz / 9999	9999
107		V/f4 voltage ①	0–1000 V	0
108		V/f5 frequency ①	0–120 Hz / 9999	9999
109		V/f5 voltage ①	0–1000 V	0
 Communications functions	117	Station number	0–31	0
	118	Communication speed	48 / 96 / 192	192
	119	Stop bit length/data length	0 / 1 data length 8; 10 / 11 data length 7	1
	120	Parity check presence/absence	0 / 1 / 2	2
	121	Number of communication retries	0–10 / 9999	1
	122	Communication check time interval	0–999.8 s / 9999	9999
	123	Wait time setting	0–150 ms / 9999	9999
 PID control	124	CR / LF absence/presence selection	0 / 1 / 2	1
	128	PID action selection	10 / 11 / 20 / 21	10
	129	PID proportional band	0.1–1000 % / 9999	100 %
	130	PID integral time	0.1–3600 s / 9999	1 s
	131	Upper limit for actual value	0–100 % / 9999	9999
	132	Lower limit for actual value	0–100 % / 9999	9999
	133	PID action set point via parameter	0–100 %	0 %
	134	PID differential time	0.01–10.00 s / 9999	9999

Function	Parameter	Meaning	Setting range	Default setting	
Commercial power supply switch-over	135	Switch-over sequence output terminal selection	0 / 1	0	
	136	MC switch-over interlock time at alarm occurrence	0–100 s	1 s	
	137	Start waiting time	0–100 s	0.5 s	
	138	Selection of MCs at alarm occurrence	0 / 1	0	
	139	Response frequency of MCs	0–60 Hz / 9999	9999	
Backlash	140	Backlash acceleration stopping frequency ^①	0–120 Hz	1 Hz	
	141	Backlash acceleration stopping time ^①	0–360 s	0.5 s	
	142	Backlash deceleration stopping frequency ^①	0–120 Hz	1 Hz	
	143	Backlash deceleration stopping time ^①	0–360 s	0.5 s	
Display	144	Speed setting switchover	0 / 2 / 4 / 6 / 8 / 10 / 102 / 104 / 106 / 108 / 110	4	
	145	Language selection	0–7	1	
Auxiliary functions	148	Stall prevention level at 0 V input	0–150 %	120 %	
	149	Stall prevention level at 10 V input	0–150 %	150 %	
Output current detection	152	Zero current detection level	0–200 %	5 %	
	153	Zero current detection period	0–1 s	0.5 s	
Help functions	154	Voltage reduction selection during stall prevention operation	0 / 1	1	
	155	RT activated condition	0 / 10	0	
	156	Stall prevention operation selection	0–31 / 100 / 101	0	
	157	OL signal waiting time	0–25 s	0	
	158	AM terminal function selection	1–3 / 5 / 6 / 8 / 10–14 / 17 / 21	1	
Aux. function	160	User group read selection ^②	0 / 1 / 10 / 11 / 9999	9999	
Restart	162	Automatic restart after instantaneous power failure selection	0 / 1 / 10 / 11	0	
	163	First cushion time for automatic restart	0–20 s	0 s	
	164	First cushion voltage for automatic restart	0–100 %	0 %	
	165	Restart stall prevention operation level	0–150 %	120 %	
Aux. functions	168	Parameters set by the manufacturer. Do not set!	—	—	
	169		—	—	
Initial monitor	170	Watt-hour meter clear	0	0	
	171	Current operation hour meter clear	0	0	
User functions	173	User group 1 parameter registration	0–999	0	
	174	User group 1 parameter deletion	0–999 / 9999	0	
	175	User group 2 parameter registration	0–999	0	
	176	User group 2 parameter deletion	0–999 / 9999	0	
Terminal functions selection	180	RL terminal function selection	0–7 / 10–14 / 16 / 9999	0	
	181	RM terminal function selection		1	
	182	RH terminal function selection		2	
	183	RT terminal function selection		3	
	184	AU terminal function selection		4	
	185	JOG terminal function selection		5	
	186	CS terminal function selection		6	
	190	RUN terminal function selection		0	
	191	SU terminal function selection		0–5 / 8 / 10 / 11 / 13–19 / 25 / 26 / 98–105 / 108 / 110 / 111 / 113–116 / 125 / 126 / 198 / 199 / 9999	1
	192	IPF terminal function selection		2	
	193	OL terminal function selection		3	
	194	FU terminal function selection		4	
	195	ABC terminal function selection		99	
Aux. function	199	User's initial value setting	0–999 / 9999	0	
Help functions	240	Soft-PWM setting ^②	0 / 1	1	
	244	Cooling fan operation selection	0 / 1	0	
Aux. functions	251	Output phase failure protection selection	0 / 1	1	
	252	Gain overlay for setting voltage	0–200 %	50 %	
	253	Offset overlay for setting voltage	0–200 %	150 %	

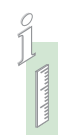
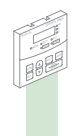

PARAMETERS

Function	Parameter	Meaning	Setting range	Default setting
Special functions	300 – 337	Parameters for inboard options (optional selectable if appropriate option board is installed)	Refer to the options instruction manual for further details.	Refer to the options instruction manual for further details.
Communi- cations functions	338	Operation command write	0 / 1	0
	339	Speed command write	0 / 1	0
	340	Link start mode selection	0 / 1 / 2	0
	341	CR LF precense/absent selection	0 / 1 / 2	1
Aux. functions	342	E ² PROM write selection	0 / 1	0
Advanced PID control	500	Auxiliary motor operation selection	0 / 1 / 2 / 3	0
	501	Motor switch-over selection	0 / 1 / 2	0
	502	MC switching interlock time	0–100 s	1 s
	503	Start waiting time	0–100 s	1 s
	504	Auxiliary motor connection-time deceleration time	0–3600 s	1 s
	505	Auxiliary motor disconnection-time acceleration time	0–3600 s / 9999	1 s
	506	Output stop detection time	0–3600 s / 9999	9999
	507	Output stop detection level	0–120 Hz	0 Hz
	508	Output stop cancel process value level	0–100 %	100 %
	509	Auxiliary motor 1 starting frequency	0–120 Hz	50 Hz
	510	Auxiliary motor 2 starting frequency	0–120 Hz	50 Hz
	511	Auxiliary motor 3 starting frequency	0–120 Hz	50 Hz
	512	Auxiliary motor 1 stopping frequency	0–120 Hz	0 Hz
	513	Auxiliary motor 2 stopping frequency	0–120 Hz	0 Hz
	514	Auxiliary motor 3 stopping frequency	0–120 Hz	0 Hz
	515	Auxiliary motor start delay frequency	0–3600 s	5 s
516	Auxiliary motor stop delay frequency	0–3600 s	5 s	
Calibration functions	571	Starting frequency holding time	0–10 s / 9999	9999
	900	FM terminal calibration ^②	Calibration range	—
	901	AM terminal calibration ^②	Calibration range	—
	902	Frequency setting voltage bias	0–60 Hz / [0–10 V]	0 Hz / [0 V]
	903	Frequency setting voltage gain	1–120 Hz / [0–10 V]	50 Hz / [5 V]
	904	Frequency setting current bias	0–60 Hz / [0–20 mA]	0 Hz / [4 mA]
	905	Frequency setting current gain	1–120 Hz / [0–20 mA]	50 Hz / [20 mA]
Auxiliary functions	990	Buzzer control for keyboard	0 / 1	1
	991	Calibration for the LC display of the parameter unit	0–63	53

Remarks to the table:

- ① Can only be accessed, if parameter 29 is set to the value 3.
- ② These parameters allow their settings to be changed during operation if 0 (factory setting) has been set in Pr. 77. (Note that the Pr. 72 and Pr. 240 settings cannot be changed during external operation.). Whether a parameter can be changed during operation depends also on the setting of parameter 160. This parameter is factory set to "9999" which means that a parameter setting is not possible before this parameter 160 is changed. For more detailed informations please refer to the FR-F500 users manual.

Protective Functions Overview

The frequency inverter FR-F 540L EC provides a large number of protective functions that protect the drive and the inverter against damage in case of any malfunction.

If an error occurs, the output of the inverter is suspended and the control panel returns an error message.

Display on control panel FR-DU04	Meaning	Description	Remedy
E.OC1	Overcurrent 1 (acceleration)	A) The output current of the inverter has reached or exceeded 200 % of the rated current during the acceleration, deceleration, or at constant speed. B) The temperature of the main circuits of the inverter rises rapidly.	The cause for the activation of the protective function is a short circuit or a ground fault across the main outputs, an exceeding moment of inertia of the load (GD^2), too short acceleration / deceleration time presets, restart during a motor idling phase, operation of a motor with an exceeding capacity. Overheating due to insufficient cooling (defective cooling fan or choked heat sink).
E.OC2	Overcurrent 2 (const. speed)		
E.OC3	Overcurrent 3 (deceleration)		
E.OV1	Overvoltage 1 (acceleration)	The converter voltage has increased highly due to regenerative energy. The overvoltage limit was exceeded during acceleration, deceleration, or at constant speed.	In most cases the protective function is activated due to a too short deceleration time preset or a regenerative overload. Remedy by increasing the deceleration time of connecting an external brake unit. An overvoltage in the mains power supply activates this protective function as well.
E.OV2	Overvoltage 2 (constant speed)		
E.OV3	Overvoltage 3 (deceleration)		
E.THM	Overload (motor)	The electronic overload protection for the motor or inverter was activated. The electronic motor protection switch continually detects the motor current and the output frequency of the inverter. If a self-cooling motor operates over a long period at low speed but high torque, the motor is thermally overloaded and the protective function is activated.	Decrease the motor load to avoid an activation. Check whether the performance range of the motor and inverter correspond.
E.THT	Overload (inverter)	If several motors are operated by one inverter the motor protection switch will not operate properly. In this case deactivate the motor protection and replace it by external protection switches.	
E.IPF	Instantaneous power failure protection	The output of the inverter is suspended and the alarm message returned, if the power supply fails for more than 15 ms. If the power supply fails for more than 100 ms, the inverter shuts down completely. In this case after restoring the power supply the inverter is in the power ON state. If the power failure stays below 15 ms, the operation is proceeded normally.	Check the power supply.
E.UVT	Undervoltage	The input voltage of the inverter has fallen below the minimum value. The protective function is activated, if the input voltage falls below the minimum value.	An undervoltage can occur, if the capacity of the mains transformer is not sufficient or if a high capacity motor is turned ON connected to the same mains supply circuit.
E.FIN	Overheating of heat sink	In case of an overheating of the heat sink the temperature sensor responds and the inverter is stopped.	Check ambient temperature.
E.GF	Ground failure	An overcurrent occurred due to a ground failure upon the inverter output (load).	Check load connections (motor circuit).
E.OHT	Activation of an external motor protection relay (thermal contact)	An external motor protective switch was activated. If an external motor protective switch for thermal monitoring is used, this switch can activate the protective function of the inverter.	Check motor load and drive.
E.OLT	Stall prevention overload	A long lasting excess of the current limit (OL display) shut down the inverter.	Reduce the load. Check the preset values for the current limit (parameter 22) and the stall prevention selection (parameter 156).
E.OPT	Error in an optional unit	A dedicated inboard option does not operate properly. The protective function is activated, if an internal option is improperly installed or connected.	Check connections and connectors of the optional unit.
E.OP1 bis E.OP3	Error in combination with an option board	The protective function is activated for a fault (e.g. transmission error) of an internal optional unit.	Check the function settings of the optional unit.
E.PE	Memory error	Error on access of the data memory of the inverter.	Please contact your nearest MITSUBISHI ELECTRIC representative if the error occurs repeatedly.
E.PUE	Control panel connection error	A connection error between inverter and control panel occurred during operation. This alarm is only returned, if parameter 75 is set to "2", "3", "16", or "17".	Check the connection of control panel.



Display on control panel FR-DU04	Meaning	Description	Remedy
E.RET	Automatic restart retry exceeded	After activation of a protective function the inverter failed to be restarted automatically within the number of retries specified in parameter 67.	Remedy the actual cause of the originary protective function.
E.CPU	CPU error	Scan time of CPU was exceeded.	Restart the inverter. Contact the customer service if the error occurs again.
E.E6	CPU error	Communication error with the built-in CPU	Restart the inverter. Contact the customer service if the error occurs again.
E.E7	CPU error		
Err	Error	CPU error	Please contact your nearest MITSUBISHI ELECTRIC representative if the error occurs repeatedly.
E.LF	Open output phase protection	One of the phases (U, V, W) is not connected.	Check the connections.
E.P24	24 V DC power output short circuit	The 24 V DC output at the PC terminal is short circuited.	Eliminate short circuit.
E.CTE	Short circuit in the control panel	The power supply of the control unit is short circuited.	Eliminate short circuit. Check the control panel and the connecting cable.
PS	Inverter was stopped via control panel	STOP key on the control panel was pressed during external operating mode.	Check the parameter 77.
OL	Overcurrent during acceleration	If a current of more than 120% ^② of the rated inverter current flows in the motor, this function stops the increase in frequency until the overload current reduces to prevent the inverter from resulting in overcurrent shut-off. When the overload current has reduced below 120%, this function increases the frequency again.	Increase the stall prevention operation level with Pr. 22 "stall prevention operation level" or disable stall prevention with Pr. 156 "stall prevention operation selection".
	Overcurrent during constant speed operation	If a current of more than 120% ^② of the rated inverter current flows in the motor, this function lowers the frequency until the overload current reduces to prevent overcurrent shut-off. When the overload current has reduced below 120%, this function increases the frequency up to the set value.	
	Overcurrent during deceleration	If a current of more than 120% ^② of the rated inverter current flows in the motor, this function stops the decrease in frequency until the overload current reduces to prevent the inverter from resulting in overcurrent shut-off. When the overload current has reduced below 120%, this function decreases the frequency again.	
oL	Overvoltage during deceleration	If the regenerative energy of the motor increases too much to exceed the brake capability, this function stops the decrease in frequency to prevent overvoltage shut-off. As soon as the regenerative energy has reduced, deceleration resumes.	Increase the deceleration time with Pr. 8 "deceleration time".
E.15 ^①	Main circuit failure	The heat sink of brake unit is overheated.	Reduce the load moment or brake frequency; clean the heat sink; replace the cooling fan
		DC fuse is blown.	Eliminate the short-circuit and replace the fuse
		The control board is overheated.	Replace the cooling fan; check the ambient temperature
		An overcurrent on the output has occurred.	Eliminate the short-circuit or short to ground; replace the motor; increase the brake time; reduce the load fluctuations, increase the acceleration time; check the brake operation
		Power supply for cooling fan fails.	Eliminate the short-circuit; replace the power supply for cooling fan; replace the fuse
		General overcurrent	Eliminate the short-circuit and replace the fuse; eliminate the short-circuit on output or short to ground; replace the motor and reduce the load
		The heat sink is overheated.	Clean or replace the heat sink; check the ambient temperature
A gate power supply failure has occurred.	Eliminate the short-circuit; replace the gate power supply		

^① Please refer to the FR-F500 user's manual for a detailed description of the error message E.15.

^② The stall prevention operation current may be set as desired (Pr. 22). It is factory-set to 120%

Resetting Methodes

When a protective function is activated, the output of the inverter is switched off. The motor coasts to a halt. The output remains switched off until the error cause is eliminated and the inverter reset. The inverter can be reset following three different methods:

- Switch the power supply OFF and ON again.
- Switch the reset signal ON for at least 0.1 s.
- Press the RESET key on the control panel.

If the reset signal is ON continuously, the control panel FR-DU04 returns an error message while the control unit FR-PU04 indicates that the reset procedure is in progress.

When a protective function is activated, the control panel FR-DU04 returns an error code as listed in the table above. The control panel FR-PU04 returns error messages in clear.

If on occurrence of an error the input protection contactor is toggled the error message cannot be retained, since there is no power supply for the control circuit. If the error message is intended to be retained in spite of an activation of the protective contactor, the control circuit has to be supplied by a separate power supply.

Separate power supply for the control circuit

The figure on the right shows the connection of the separate 380-480 V AC (-15%/+10%) power supply for the control circuit. The current consumption is 2 A.

Prior to the connection remove the two short bars upon L11 and L21 on the inverter.

Please refer to the according manual for a precise description of the connection.

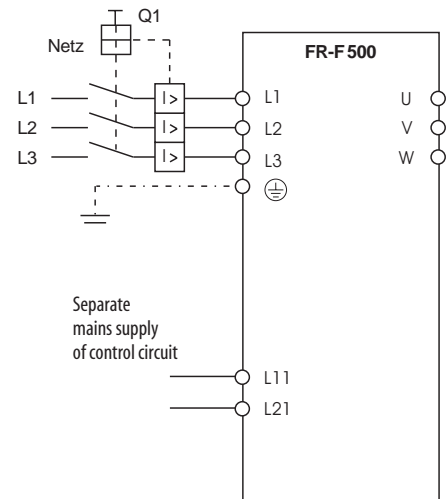

Application Examples

Moulding machine

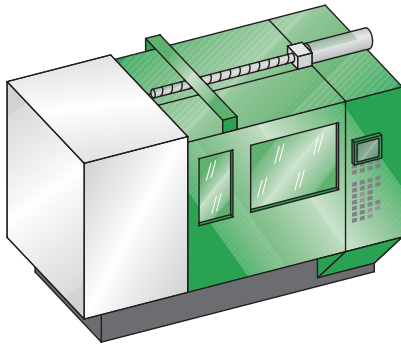

Hydraulic injection moulding machines are used in many factories for producing plastic components. The hydraulic pumps are powered by electric motors – usually asynchronous 3-phase AC motors – which are frequently very powerful.

In some steps of the manufacturing process the power consumption of the injection moulding machines is considerably lower than the peak value. Frequency inverters make it possible to save power in the periods when loads are low, and they can easily be retrofitted at any time.

Specifications

- Injection moulding machine with 200 tons injection pressure
- Drive system with 6-pole motor, 75 kW
- Frequency inverter: FR-F 540L
- Acceleration/braking times setting: 2 s
- Control with 2 preset frequencies
- Operation modes: 60 Hz during the injection sequence, 20 Hz the rest of the time
- Injection moulding machine power consumption per cycle in normal mode: 8.5 kWh
- Injection moulding machine power consumption per cycle with frequency inverter control: 3.2 kWh

Benefits

- Energy savings
Reducing the hydraulic pump motor frequency by 20 – 30 Hz during the cooling sequence brings energy savings of 20 – 40 %.
- Simple installation
Frequency inverters can be retrofitted to existing systems quickly and easily. No time-consuming modifications are required.
- Less wear
Installing a frequency inverter reduces the oil temperature and extends the service life of the system.
- Improved environmental conditions
Reducing motor speed in low-load phases cuts noise levels and the vibration caused by the machine.
- Flux optimisation mode
The FR-F 540L frequency inverter can also dynamically optimise the voltage to motor requirements, thus maximising motor efficiency.

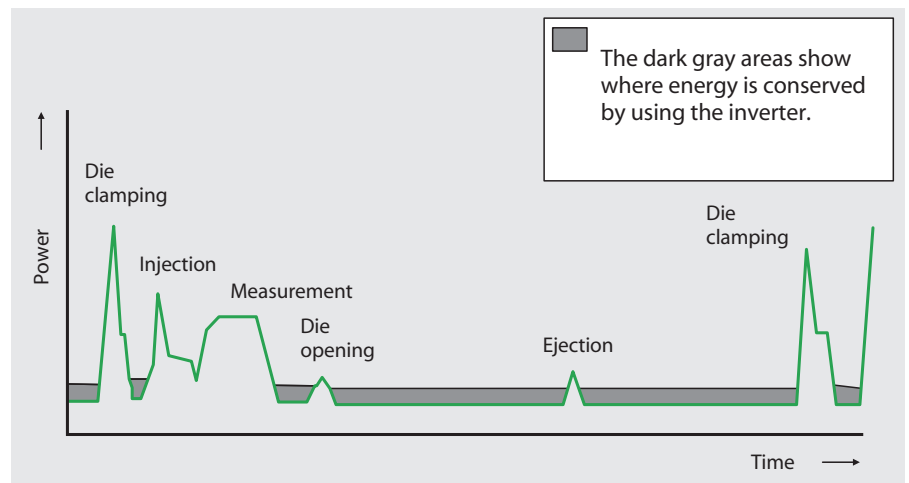

Stamping press
(small metal parts production)

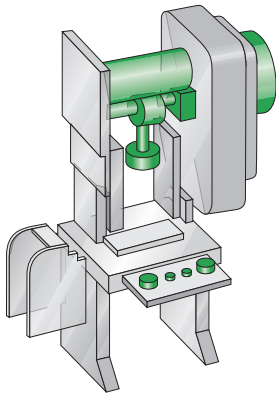

Retrofitting this stamping press with the FR-F 540L frequency inverter brought significant energy savings. The secret is the FR-F 540L's intelligent Flux Optimisation mode. During the phase of the stamping sequence with low overload requirements Flux Optimisation mode quickly reduces the motor voltage.

The rapid Flux Optimisation response time is the key to success – after the low-load phase the voltage is increased again just as quickly for the next stamping sequence.

Specifications

- Manually-operated stamping press with 400 tons stamping pressure
- Powered by a 4-pole motor (55 kW)
- Frequency inverter: FR-F 540L-75k
- Operation: The press is operated with the motor running at constant speed. During the stamping sequence the power required for punching out the metal components is transferred briefly to the punch by engaging a magnetic clutch coupling.
- Power consumption: As the graphs below show, the power consumption of the press is identical for both pressing operations.

However, the low load cycle power consumption (magnetic clutch disengaged) drops when a frequency inverter is used:

Normal operation of the stamping press: 7.8 kW

Stamping press operated with frequency inverter: 5.3 kW

- Depending on the design of the drive system used it may also be necessary to use an (optional) brake resistor in applications like this.

Benefits

- Energy savings
Flux optimisation mode prevents unnecessary power consumption. Energy is conserved in every phase of the cycle when the motor load is less than 100 %.
- Simple installation
Retrofitting applications like this stamping press with a frequency inverter is very quick and trouble-free.
- Enhanced precision
The option of variable motor speed provides better control over your application and thus improves manufacturing precision and product quality.

Normal operation without Flux Optimisation

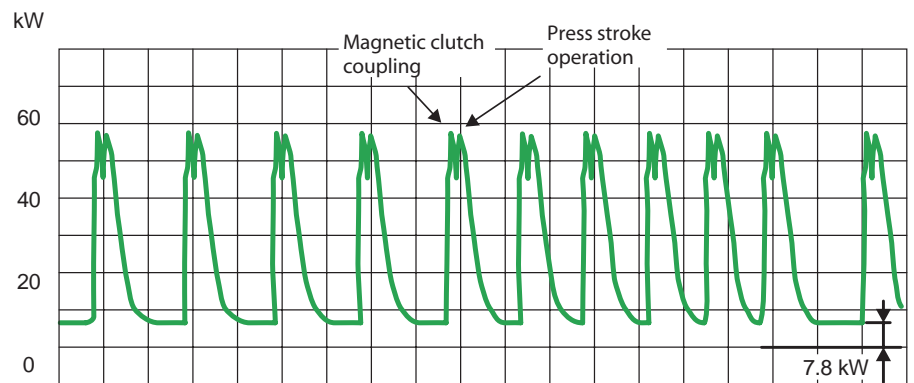

Operation of the press with Flux Optimisation

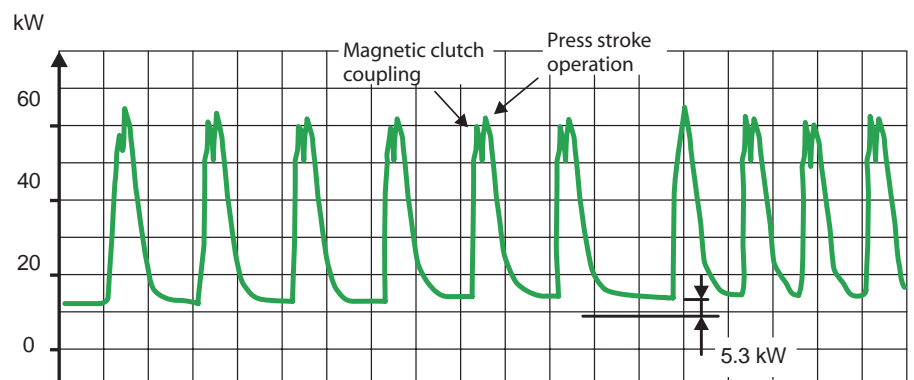

Internal and External Options

A large number of options allows an individual adoption of the inverter to the according task. The options can be installed quickly and easily. Detailed information on installation and functions is included in the manual of the options.

The options can be divided into two major categories:

- internal options
- external options

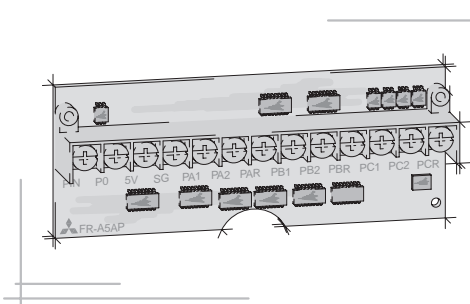

Internal options

The internal options comprise input and output extensions as well as communications options supporting the operation of the inverter within a network or connected to a personal computer or PLC. The optional connection of a PLG supports a position control and via a feedback loop a precise speed control.

Option	Type	Description	Remarks / specifications	Art. no.		
Internal options	12-bit digital input	FR-A5AX	Interface for the input of the frequency setting via 3-digit BCD or 12-bit binary code, setting of gain and bias supported.	Input: 24 V DC; 5 mA; open collector or switching signal, sink or source logic	68039	
	Digital output	FR-A5AY	Selectable 7 of 27 standard output signals of the inverter can be output at the open collector.	Output load: 24V DC; 0,1 A, sink or source logic	68040	
	Expansion analog output		Selectable 2 of 16 additional signals (e.g. output frequency, output voltage, output current) can be output and indicated at the FM / AM output. Display on measuring gauge: 20 mA DC or 5 V (10 V) DC	Output: max. 0 – 10 V DC; 0 – 20 mA; Resolution: 3 mV at voltage output, 1 μA at current output, accuracy: ±10 %		
	Relay output	FR-A5AR	Selectable 3 of 27 standard output signals of the inverter can be output through relay terminals.	Switching load: 230 V AC/0.3 A, 30 V DC/0.3 A	68038	
	PTC monitor	OI-FR-APTC	The PTC board is a device that is capable to give an overtemperature alarm by detecting the ohmic value of one PTC resistance.	Connection of PTC resistors series KTY	147224	
	Communications	Computer link	FR-A5NR	Via this additional RS422 or RS485 compatible interface the operation, display functions, and parameter settings can be controlled by a computer (PC etc.). For minimum noise use twisted pair cables for the connection.	EIA RS485 and RS422, Multi-Drop operation, max. 19.200 Baud; max. 500 m, connection of up to 32 inverters supported	68046
		Profibus/DP	FR-A5NPA	Option board for the integration of a frequency inverter into a Profibus/DP network. The operation, display functions, and parameter settings can be controlled by a computer (PC etc.) or a PLC.	Connection of up to 126 inverters supported. Maximum transfer rate: 12 MBaud	141680
		DeviceNet™	FR-A5ND	Option board for the integration of a frequency inverter into a DeviceNet. The operation, display functions, and parameter settings can be controlled by a computer (PC etc.) or a PLC.	Maximum transfer rate: 10 MBaud	68043
		CC-Link	FR-A5NC	Option board for the integration of a frequency inverter into a CC-Link network. The operation, display functions, and parameter settings can be controlled by a PLC.	Maximum transfer distance: 1200 m (at 156 x 10 kBaud)	68042
		Modbus Plus	FR-A5NM	The operation, display functions, and parameter settings can be controlled by a computer (PC etc.) or a PLC.	Maximum transfer distance: 100 m (at 10 kBaud)	68044
	CANopen	FR-A5NCO	Option board for the integration of a frequency inverter into a CANopen network. The operation, display functions, and parameter settings can be controlled by a computer (PC etc.) or a PLC.	Maximum transfer rate: 1 MBaud	139377	
Accessories	PCMCIA communications card	SioCard	Connection between mobile PC (PCMCIA) and frequency inverter RS485 (RJ45); no external power supply necessary	Length 3 m; for parametrization and programming of the frequency inverter; it can be used for example with the VFD setup software	69946	
	Connection cable	SC-FR PC	Connection between PC (RS232) and frequency inverter RS485 (RJ45); no external power supply necessary		88426	

External Options

Besides the control panel FR-PU04 that provides an interactive control of the inverter the external options comprise noise filters complying with the EMC directives,

power chokes improving the efficiency as well as brake units and brake resistors.

Option	Type	Description	Remarks/Specifications	Art. no.	
External options	Control panel (8 languages)	FR-PU04	Interactive control panel with LCD display.	Refer to p.13 for detailed description	67735
	Connecting cable for control panel	FR-A5 CBL	Cable for a remote connection of the control panel FR-DU04 or FR-PU04.	Available length: 1; 2.5 and 5 m	1 m: 70727 2,5 m: 70728 5 m: 70729
	Connection cable	SC-FR PC	Communications cable for RS232 or RS485 interface to connect an external personal computer	Length 3 m; can be used for example with the VFD setup software	88426
	VFD setup software	FR-SW0-SETUP-W□	Parameterization and setup software for the whole FR-F 500 series as well as all other Mitsubishi inverter series.	English / German	149718
	EMC noise filter	FN 3359-□□□	Noise filter for compliance with EMC directives.	Refer to p.26 for detailed description	see p. 26
	DC converter circuit choke coil	MT-BEL ①	For an increased efficiency and compensation of voltage fluctuations.	Refer to p.26 for detailed description	—
	Brake units	MT-BU 5, BU-UFS	For an improvement of the brake capacity. For loads with high moment of inertia or negative loads. Used in combination with a resistor unit.	Refer to p.27 for detailed description	see p. 27
External brake resistors	MT-BR 5, RUFC	To improve the brake capacity of the inverter; is used in combination with a brake unit	Refer to p.27 for detailed description	see p. 27	

① The DC converter circuit choke coil is standard equipment of the FR-F 540L EC type inverters. This choke coil is required for the operation of the inverter.

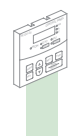

Mounting examples for internal and external options

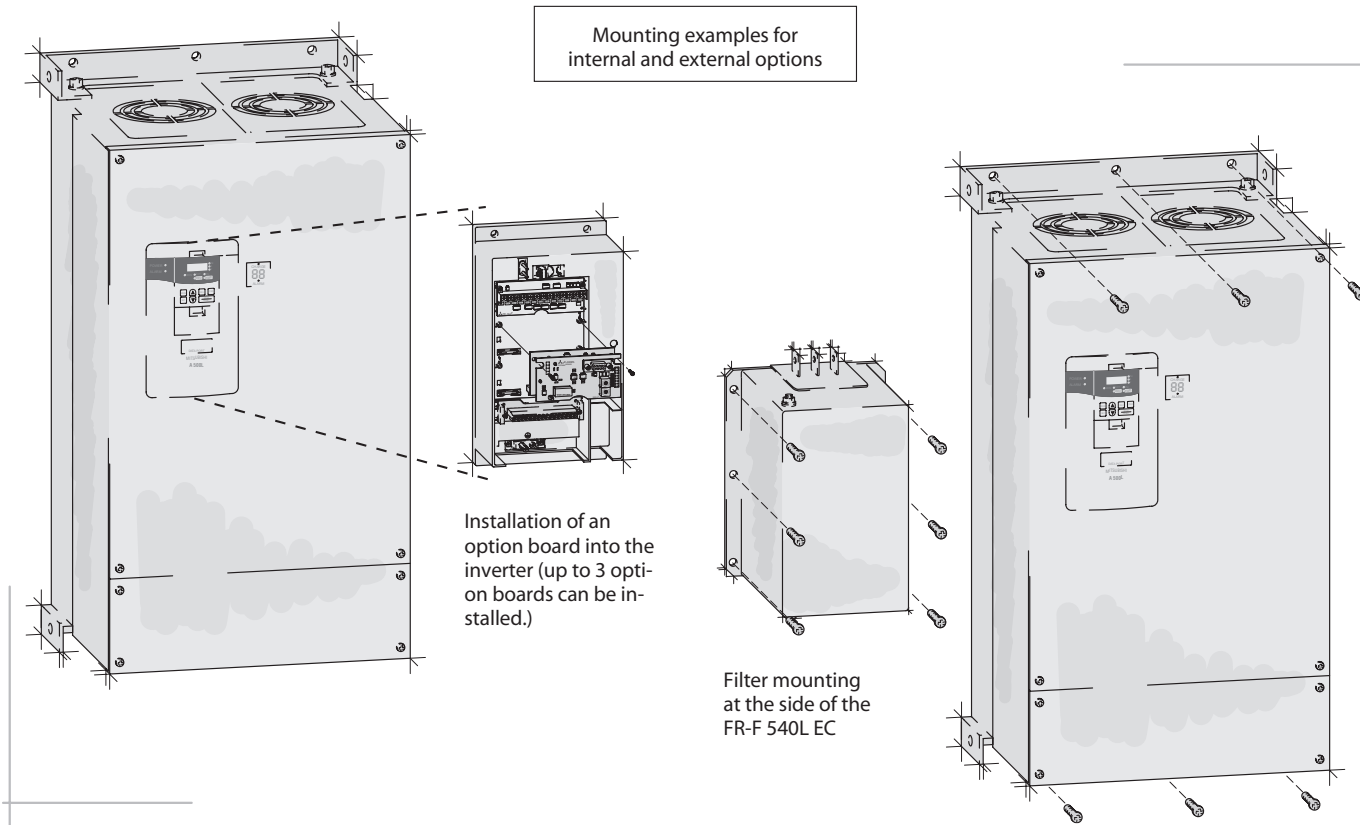

■ Noise Filters

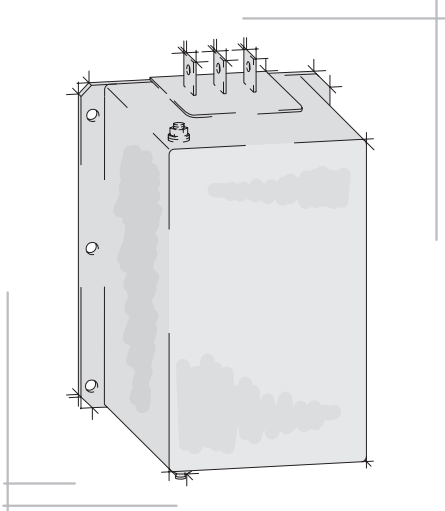

Noise filters for high capacities

The extremely compact line of FN 3359 filters provides the user with an efficient noise suppression at low room requirements.

The FN 3359 filters are suitable for noise suppression conforming to EN 61800-3.

These filters make it possible to stay within the Environment 2 interference limits for variable-speed electrical power drive systems (corresponds to EN 5011 Class A) with motor power cables up to 100 m long (shielded).

Filter	Inverter FR-F 540 L EC	Power loss [W]	Class	Leakage current [mA]	Weight [kg]	Art. no.
FN 3359-180-28	75 k–90 k	34	A	< 6	6.5	141097
FN 3359-250-28	110 k	38	A	< 6	7	104663
FN 3359-400-99	132 k–185 k	51	A	< 6	10.5	104664
FN 3359-600-99	220 k–280 k	65	A	< 6	11	104665
FN3359-1000-99	375 k–450 k	84	A	< 6	18	104666
FN3359-1600-99	530 k	130	A	< 6	27	130229

■ DC Reactors

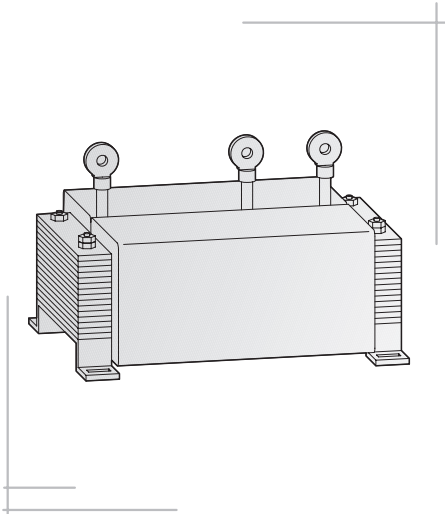
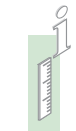

DC link reactors

A DC link reactor is included as standard equipment with the FR-F540L EC frequency inverters. This reactor is essential for the operation of the inverter and must be installed.

The function of these reactors corresponds to that of the three-phase mains supply chokes described above.

Application (inverter)	Power loss [W]		Weight [kg]	Art. no.
	at 120 %*	at 150 %*		
FR-F 540L-75 k	133	133	14	A DC link reactor is included as standard equipment with the respective frequency inverter.
FR-F 540L-90 k	146	146	18	
FR-F 540L-110 k	192	166	19	
FR-F 540L-132 k	202	192	22	
FR-F 540L-160 k	214	202	22	
FR-F 540L-185 k	253	214	29	
FR-F 540L-220 k	260	253	36	
FR-F 540L-280 k	312	276	48	
FR-F 540L-375 k	396	372	57	
FR-F 540L-450 k	530	450	100	
FR-F 540L-530 k	530	530	100	

*Overload capacity

Brake Units

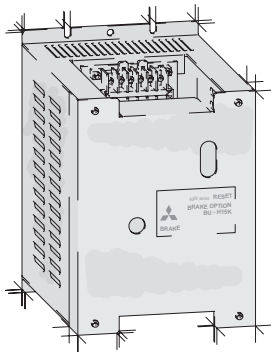

The capacitors in the converter circuit provide a braking torque of approx. 20 % of the rated motor torque. If a higher braking torque or is required, an external brake unit is required.

Brake resistors (see below) are to be provided application related. Regarding the selection of a suitable brake resistor you should contact MITSUBISHI ELECTRIC. The brake unit and brake resistor are connected according to the connecting diagram on the left.

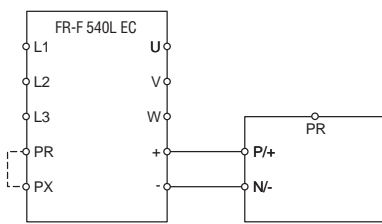

Brake unit

Inverter	Brake unit	Number of required units for inverter	Braking torque	Art. no.
FR-F 540L	MT-BU5-H75 k	1 x MT-BR5-H75 k	100 %, 10 % ED	125700
	MT-BU5-H150 k	2 x MT-BR5-H75 k	100 %, 10 % ED	125701
	MT-BU5-H220 k	3 x MT-BR5-H75 k	100 %, 10 % ED	125702
	MT-BU5-H280 k	4 x MT-BR5-H75 k	100 %, 10 % ED	125703
	MT-BU5-H375 k	5 x MT-BR5-H75 k	100 %, 10 % ED	125705

Inverter	Brake unit	Max. peak current [W]	Max. instantaneous power [kW]	Max. duty cycle	Art. no.
FR-F 540L	BU-UFS110	140	105	5 %	127950

External Brake Resistor MT-BR for Brake Unit MT-BU

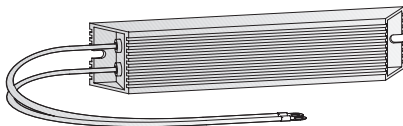

The brake resistor MT-BR5 for the frequency inverters FR-F 540L EC is used exclusively in combination with a brake unit (see above).

- Prior to the connection of the external brake resistor remove the short bar across terminals PR and PX, then connect it to terminals PR and +.

- The regenerative brake duty should be set at levels below the permissible brake duty specified in the table.
- Since the temperature of the brake resistor may exceed 300 °C take care to provide a sufficient heat dissipation.

Brake resistor	Regenerative brake duty	Resistance [Ω]	Art. no.
MT-BR5-H75 k	6 %	6.5	125699

Brake Resistors RUFC for Brake Unit BU-UFS

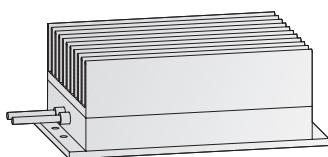

The brake resistors RUFC for the frequency inverters FR-F 540L EC are designed for the exclusive use in combination with a brake unit BU-UFS.

Please, note the specifications for the allowed duty cycle (ED max.) included in the instruction manual for the brake unit!

Type	Application	Regenerative brake duty	Resistance [Ω]	Capacity [W]	Art. no.
RUFC110 (Set)	BU-UFS 110	10 %	4 x 6.8	2000	129631

DIMENSIONS

Control Panel FR-DU04

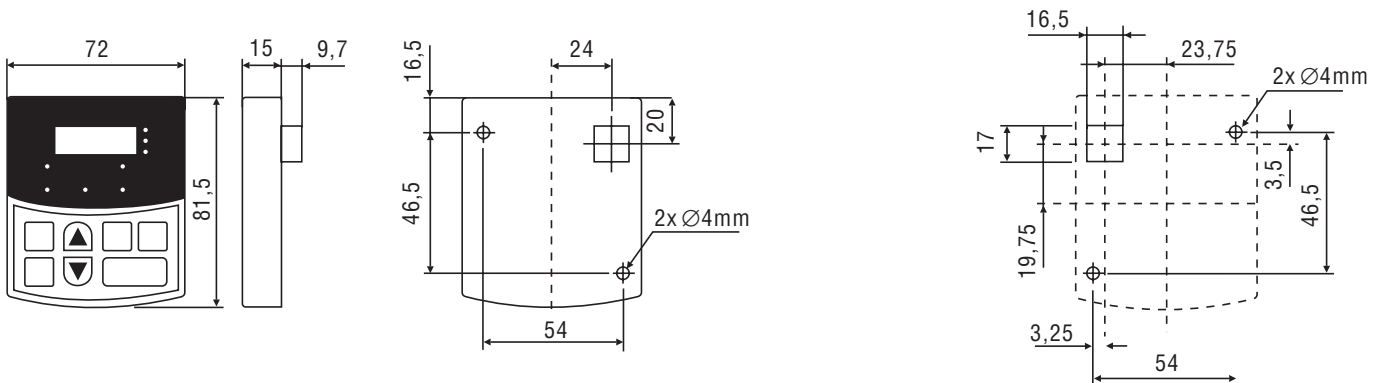

All dimensions in mm

Control Panel FR-PU04

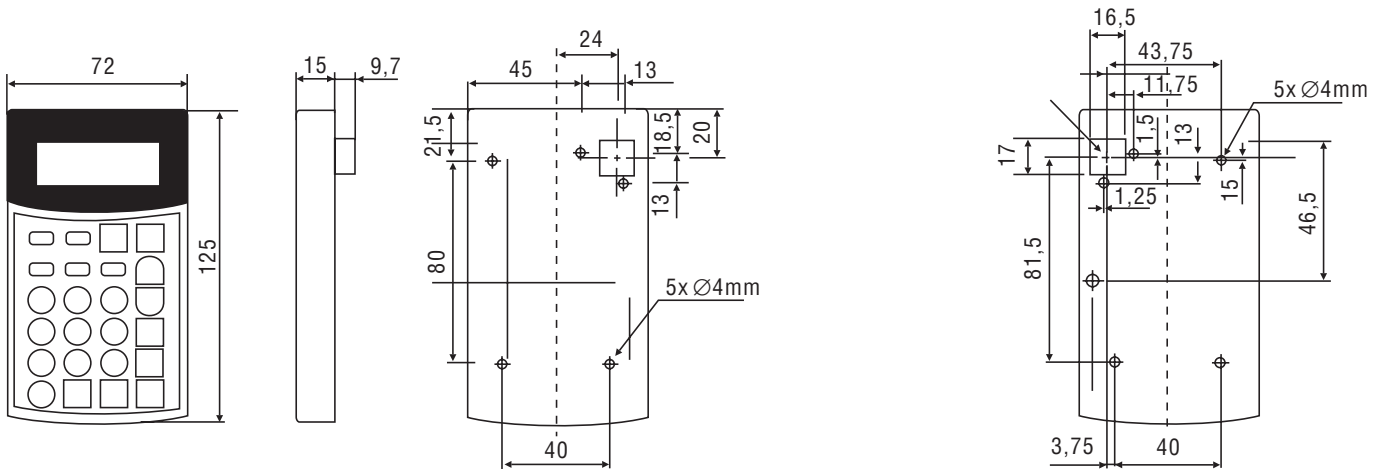

All dimensions in mm

Connection of the control panel

The control panel can be attached on the inverter after removing the protective cover. The control panel can be connected to the inverter remotely via the connecting cable type FR-A5-CBL (1m; 2.5m; 5m). You must only use the original MITSUBISHI ELECTRIC cable. This cable is available as optional accessory. Plug the cable in the according connectors on the control panel and the inverter.

The figure besides shows the pin assignment of the connector plugs.

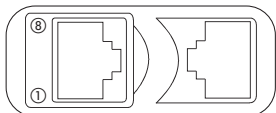

- ① SG
- ② P5S
- ③ RDA
- ④ SDB
- ⑤ SDA
- ⑥ RDB
- ⑦ SG
- ⑧ P5S

Never connect fax modems or modular telephone plugs with the connectors. Otherwise, the inverter might be damaged.

The connection of the control panel can be done with the communications cable SC-FR PC. A connection of the control panel to a personal computer is possible too.

FR-F 540L EC 75 k to 160 k

Type	A	A1	A2	B	B1	C	D
FR-F 540L-75 k	360	260	336	610	584	360	160
FR-F 540L-90 k FR-F 540L-160 k	480	400	456	740	714	360	160

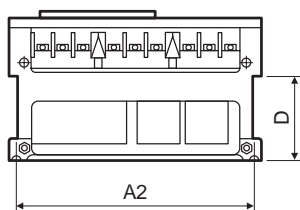
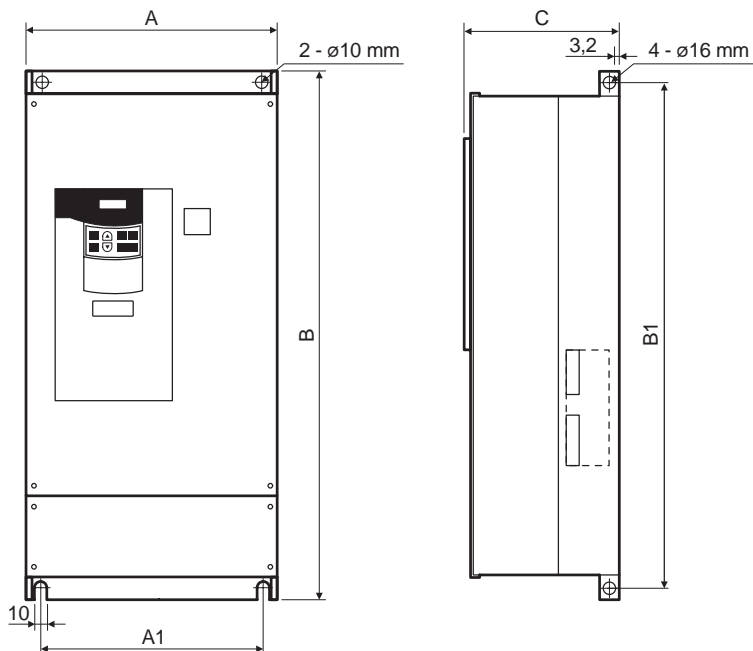

All dimensions in mm

FR-F 540L EC 185 k to 375 k

Type	A	A1	A2	B	B1	C	D	E
FR-F 540L-185 k	498	200	474	1010	984	380	185	10
FR-F 540L-220 k	498	200	474	1010	984	380	185	10
FR-F 540L-280 k	680	300	656	1010	984	380	185	10
FR-F 540L-375 k	790	316	766	1330	1300	440	196	12

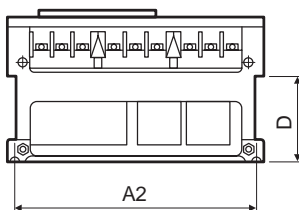
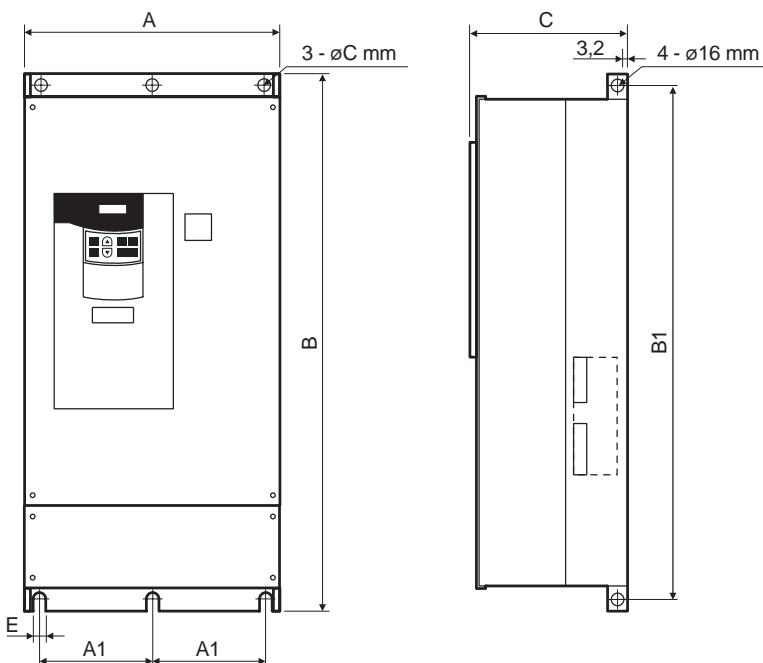

All dimensions in mm

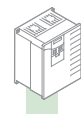

DIMENSIONS

FR-F 540L EC 450 k and 530 k

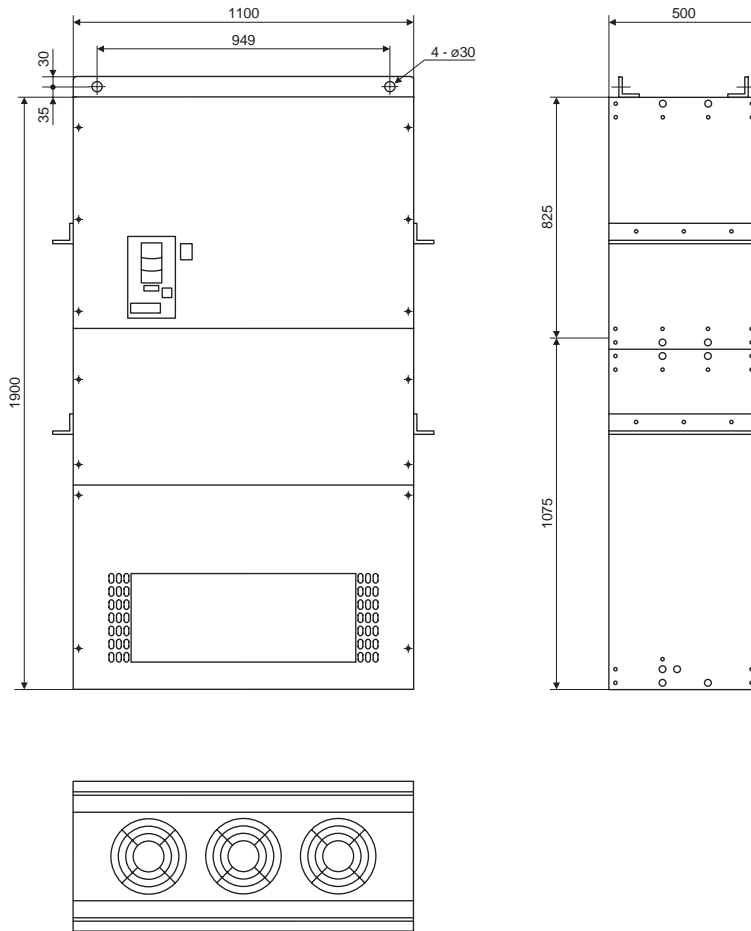

All dimensions in mm

Converter Chokes for Frequency Inverters FR-F 540L-75 k–110 k

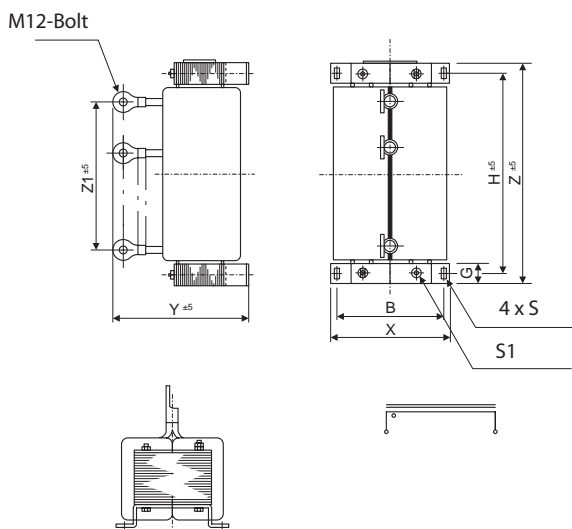

Inverter	X	Y	Z	Z1	B	H	G	S	S1	∅	Weight [kg]
FR-F 540L 75 k	140	170	320	230	130	295	25	M6	M6	M10	14
FR-F 540L 90 k	150	175	337	265	130	310	25	M6	M6	M12	18
FR-F 540L 110 k	150	180	337	255	130	310	25	M6	M6	M12	19

All dimensions in mm

Converter Chokes for Frequency Inverters FR-F 540L-132 k–220 k

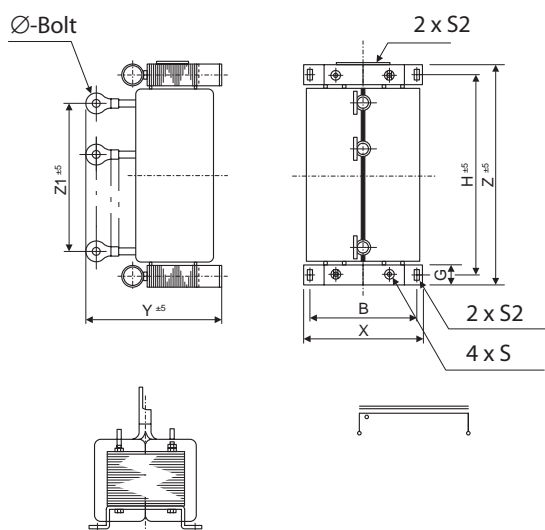

Inverter	X	Y	Z	Z1	B	H	G	S	S1	S2	∅	Weight [kg]
FR-F 540L 132 k	175	185	400	300	150	365	32	M8	M6	—	M12	22
FR-F 540L 160 k	175	190	400	315	150	365	32	M8	M6	—	M12	22
FR-F 540L 185 k	175	225	400	285	150	365	32	M8	M6	—	M12	29
FR-F 540L 220 k	190	225	438	305	165	400	38	M8	M8	M8	M12	36

All dimensions in mm

Converter Chokes for Frequency Inverters FR-F 540L-280 k–375 k

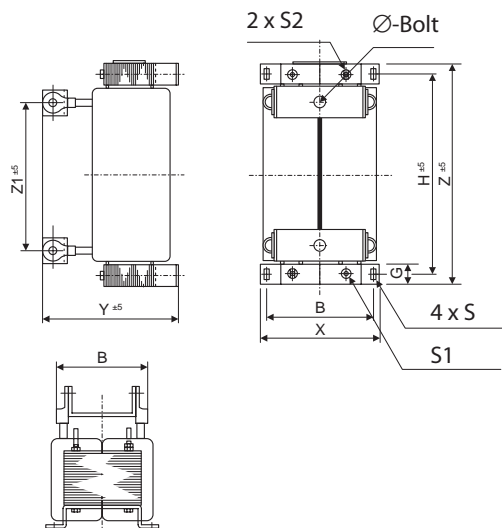

Inverter	X	Y	Z	Z1	B	H	G	S	S1	S2	∅	Weight [kg]
FR-F 540L 280 k	210	235	495	380	185	450	44	M10	M8	M8	M16	48
FR-F 540L 375 k	220	250	495	380	195	450	44	M10	M8	M8	M16	57

All dimensions in mm

DIMENSIONS

■ Converter Choke for Frequency Inverters FR-A 540L-G 375 k und 450 k

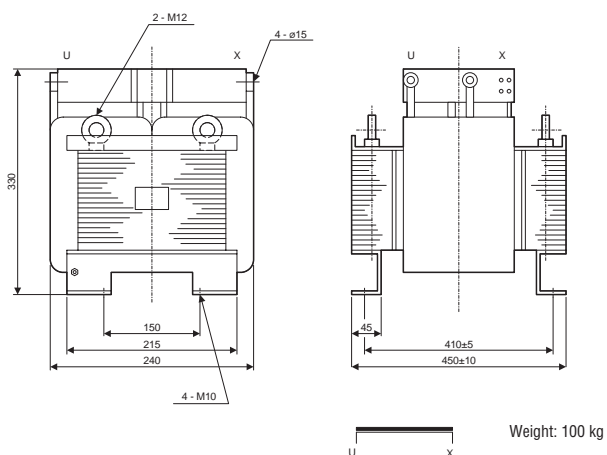

■ Noise Filters

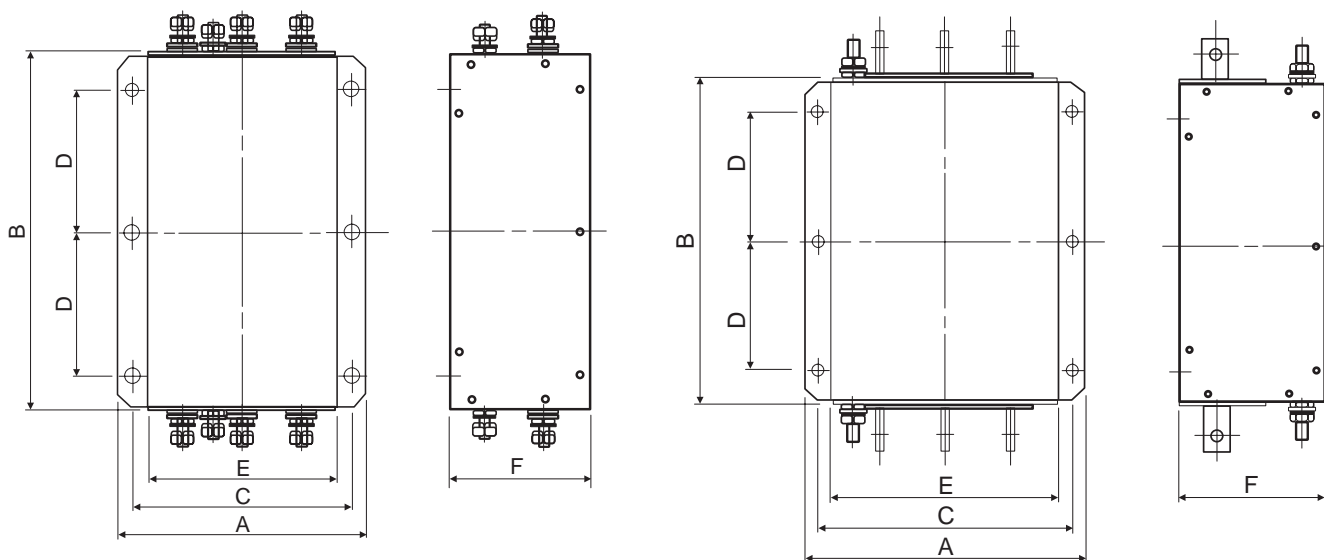

Filter	Inverter	A	B	C	D	E	F	Weight [kg]
	FR-F 540 L							
FN 3359-180-28	75 k–90 k	210	300	185	120	160	120	6.5
FN 3359-250-28	110 k	230	300	205	120	180	125	7

All dimensions in mm

Filter	Inverter	A	B	C	D	E	F	Weight [kg]
	FR-F 540 L							
FN 3359-400-99	132 k–185 k	260	306	235	120	210	115	10.5
FN 3359-600-99	220 k–280 k	260	306	235	120	210	135	11
FN 3359-1000-99	375 k–450 k	280	356	255	145	230	170	18
FN3359-1600-99	530 k	300	406	275	170	250	160	27

All dimensions in mm

■ Brake Units MT-BU5

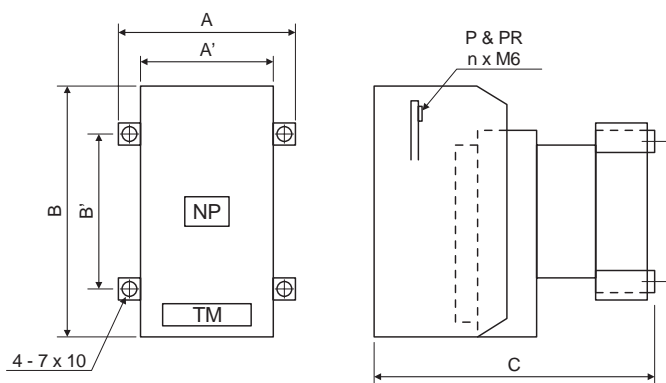

Brake unit	A	A'	B	B'	C	Weight [kg]
MT-BU5-H75K	118	90	200	100	256.5	1.5
MT-BU5-H150K	188	160	200	100	256.5	3.0
MT-BU5-H220K	258	230	200	100	256.5	4.5
MT-BU5-H280K	328	300	200	100	256.5	6.0
MT-BU5-H375K	398	370	200	100	256.5	7.5

All dimensions in mm

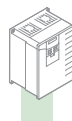

■ Brake Units BU-UFS

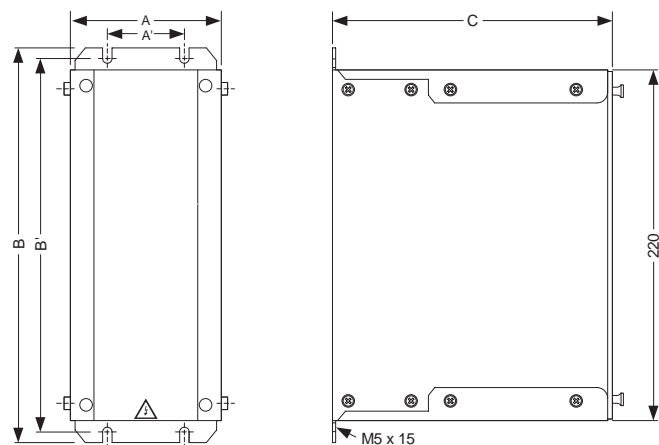

Brake unit	A	A'	B	B'	C	Weight [kg]
BU-UFS110	107	50	250	240	195	3.9

All dimensions in mm



■ External Brake Resistor MT-BR5

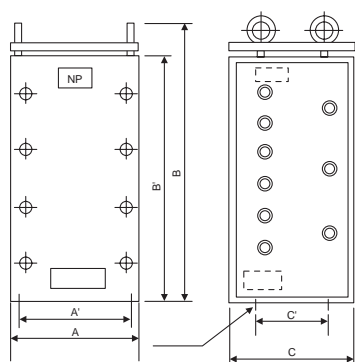

Brake resistor	A	A'	B	B'	C	C'	Weight [kg]
MT-BR5-H75 k	510	480	885	800	465	300	70

All dimensions in mm



■ External Brake Resistor RUFC

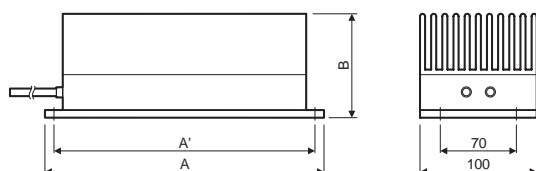

Brake resistor	A	A'	B	Weight [kg]
RUFC110	365	350	75	18.8

All dimensions in mm

A		I	
Ambient conditions	9	Internal options	24
Application examples	22	M	
Application range	4	Maintenance	7
B		Mains supply	
Block diagram	10	Frequency inverter	10
Brake units		Control circuit	21
Dimensions	33	Menu guide	
Description	27	FR-DU04 standard parameter unit	12
Brake resistors		FR-PU04 optional parameter unit	13
Dimensions	33	Motor control functions	6
Description	27	N	
C		Noise filter	
Communications possibilities	6	Dimensions	32
Converter chokes		Description	26
Description	26	O	
Dimensions	31	Operation	7
Connection		Operating conditions	9
Control units	28	Operating modes	14
Frequency inverter	10	Option boards	24
Control unit		P	
Dimensions	28	Parameter	15
FR-DU04 description	12	PID control	6
FR-PU04 description	13	Protective functions	19
D		R	
Dimensions		RESET function	21
Brake units/brake resistors	33	Resetting methods	21
Chokes	31	S	
Control units	28	Separate power supply	21
Frequency inverter	29	Signal terminals	11
Noise filter	32	Specifications	
E		Brake resistors/brake units	27
Error messages	19	Frequency inverter	8
EMC compliance	6	Noise filter	26
Energy conservation	5	Options	24
Example applications	22	System description	4
External brake resistors		T	
Description	27	Terminal designation	10
Dimensions	33		
External options	25		
F			
FR-DU04	12		
FR-PU04	13		
Frequency inverter			
Dimensions	29		
Specifications	8		
Functions			
Inverter	8		
Parameter	15		
H			
Handling			
Control units	12		
Frequency inverter	7		

HEADQUARTERS

MITSUBISHI ELECTRIC EUROPE
EUROPE B.V.
German Branch
Gothaer Straße 8
D-40880 Ratingen
Phone: +49 (0)2102 486-0
Fax: +49 (0)2102 486-1120
e mail: megfamail@meg.mee.com

MITSUBISHI ELECTRIC EUROPE B.V.
FRANCE
French Branch
25, Boulevard des Bouvets
F-92741 Nanterre Cedex
Phone: +33 1 55 68 55 68
Fax: +33 1 55 68 56 85
e mail: factoryautomation@fra.mee.com

MITSUBISHI ELECTRIC EUROPE B.V.
IRELAND
Irish Branch
Westgate Business Park, Ballymount
IRL-Dublin 24
Phone: +353 (0) 1 / 419 88 00
Fax: +353 (0) 1 / 419 88 90
e mail: sales.info@meir.mee.com

MITSUBISHI ELECTRIC EUROPE B.V.
ITALY
Italian Branch
Via Paracelso 12
I-20041 Agrate Brianza (MI)
Phone: +39 039 60 53 1
Fax: +39 039 60 53 312
e mail: factoryautomation@it.mee.com

MITSUBISHI ELECTRIC EUROPE B.V.
SPAIN
Spanish Branch
Carretera de Rubí 76-80
E-08190 Sant Cugat del Vallés
Phone: +34 9 3 565 3131
Fax: +34 9 3 589 2948
e mail: industrial@sp.mee.com

MITSUBISHI ELECTRIC EUROPE B.V.
UK
UK Branch
Travellers Lane
GB-Hatfield Herts. AL10 8 XB
Phone: +44 (0) 1707 / 27 61 00
Fax: +44 (0) 1707 / 27 86 95
e mail: automation@meuk.mee.com

MITSUBISHI ELECTRIC CORPORATION
JAPAN
Office Tower "Z" 14 F
8-12,1 chome, Harumi Chuo-Ku
Tokyo 104-6212
Phone: +81 3 622 160 60
Fax: +81 3 622 160 75

MITSUBISHI ELECTRIC AUTOMATION
USA
500 Corporate Woods Parkway
Vernon Hills, IL 60061
Phone: +1 847 478 21 00
Fax: +1 847 478 22 83

EUROPEAN REPRESENTATIVES

GEVA AUSTRIA
Wiener Straße 89
A-2500 Baden
Phone: +43 (0)2252 / 85 55 20
Fax: +43 (0)2252 / 488 60
e mail: office@geva.at

TEHNIKON BELARUS
Oktjabrskaya 16/5, Ap 704
BY-220030 Minsk
Phone: +375 (0)17 / 2275704
Fax: +375 (0)17 / 2276669
e mail: tehnikon@belsonet.net

Getronics b.v. BELGIUM
Control Systems
Pontbeeklaan 43
B-1731 Asse-Zellik
Phone: +32 (0)2 / 467 17 51
Fax: +32 (0)2 / 467 17 45
e mail: infoautomation@getronics.com

TELECON CO. BULGARIA
4, A. Ljapchev Blvd.
BG-1756 Sofia
Phone: +359 (0)2 / 97 44 058
Fax: +359 (0)2 / 97 44 061
e mail: —

INEA CR d.o.o. CROATIA
Drvinje 63
HR-10000 Zagreb
Phone: +385 (0)1 / 3667140
Fax: +385 (0)1 / 3667140
e mail: —

AutoCont CZECH REPUBLIC
Control Systems s.r.o.
Nemocnicni 12
CZ-70200 Ostrava 2
Phone: +420 59 / 6152 111
Fax: +420 59 / 6152 562
e mail: info@autocont.cz

louis poulsen DENMARK
industri & automation
Geminivej 32
DK-2670 Greve
Phone: +45 (0)43 / 95 95 95
Fax: +45 (0)43 / 95 95 91
e mail: lpia@lpmail.com

UTU Elektrotehnika AS ESTONIA
Pärnu mnt.160i
EE-10621 Tallinn
Phone: +372 6 / 51 72 80
Fax: +372 6 / 51 72 88
e mail: utu@utu.ee

UTU POWEL OY FINLAND
Box 236
FIN-28101 Pori
Phone: +358 (0)2 / 550 800
Fax: +358 (0)2 / 550 8841
e mail: tehoelektroniikka@urhotuominen.fi

UTECO A.B.E.E. GREECE
5, Mavrogenous Str.
GR-18542 Piraeus
Phone: +302 (0)10 / 42 10 050
Fax: +302 (0)10 / 42 12 033
e mail: uteco@uteco.gr

Meltrade Automatika Kft. HUNGARY
55, Harmat St.
HU-1105 Budapest
Phone: +36 (0)1 / 2605 602
Fax: +36 (0)1 / 2605 602
e mail: office@meltrade.hu

EUROPEAN REPRESENTATIVES

SIA POWEL LATVIA
Lienes iela 28
LV-1009 Riga
Phone: +371 784 2280
Fax: +371 784 2281
e mail: utu@utu.lv

UAB UTU POWEL LITHUANIA
Savanoriu Pr. 187
LT-2053 Vilnius
Phone: +370 (0)52323-101
Fax: +370 (0)52322-980
e mail: powel@utu.lt

Intehsis Srl MOLDOVA
Cuza-Voda 36/1-81
MD-2061 Chisinau
Phone: +373 (0)2 / 562 263
Fax: +373 (0)2 / 562 263
e mail: intehsis@mdl.net

Getronics b.v. NETHERLANDS
Control Systems
Donauweg 2 B
NL-1043 AJ Amsterdam
Phone: +31 (0)20 / 587 6700
Fax: +31 (0)20 / 587 6839
e mail: info.gja@getronics.com

Motion Control NETHERLANDS
Automation b.v.
Markenweg 5
NL-7051 HS Varsseveld
Phone: +31 (0)315 / 257 260
Fax: +31 (0)315 / 257 269
e mail: —

Beijer Electronics AS NORWAY
Teglverksveien 1
N-3002 Drammen
Phone: +47 (0)32 / 24 30 00
Fax: +47 (0)32 / 84 85 77
e mail: info@beijer.no

MPL Technology Sp. z o.o. POLAND
ul. Sliczna 36
PL-31-444 Kraków
Phone: +48 (0)12 / 632 28 85
Fax: +48 (0)12 / 632 47 82
e mail: krakow@mpl.pl

Sirius Trading & Services srl ROMANIA
Bd. Lacul Tei nr. 1 B
RO-72301 Bucuresti 2
Phone: +40 (0)21 / 201 7147
Fax: +40 (0)21 / 201 7148
e mail: sirius_t_s@fx.ro

ACP Autocomp a.s. SLOVAKIA
Chalupkova 7
SK-81109 Bratislava
Phone: +421 (0)7 592 22 54
Fax: +421 (0)7 592 22 48
e mail: info@acp-autocomp.sk

INEA d.o.o. SLOVENIA
Stegne 11
SI-1000 Ljubljana
Phone: +386 (0)1 513 8100
Fax: +386 (0)1 513 8170
e mail: inea@inea.si

Beijer Electronics AB SWEDEN
Box 426
S-20124 Malmö
Phone: +46 (0)40 / 35 86 00
Fax: +46 (0)40 / 35 86 02
e mail: info@beijer.de

EUROPEAN REPRESENTATIVES

ECONOTEC AG SWITZERLAND
Postfach 282
CH-8309 Nürensdorf
Phone: +41 (0)1 / 838 48 11
Fax: +41 (0)1 / 838 48 12
e mail: info@econotec.ch

GTS TURKEY
Darülaceze Cad. No. 43A KAT: 2
TR-80270 Okmeydani-Istanbul
Phone: +90 (0)212 / 320 1640
Fax: +90 (0)212 / 320 1649
e mail: gts@turk.net

CSC Automation UKRAINE
15, M. Raskovoyi St., Fl. 10, Off. 1010
U-02002 Kiev
Phone: +380 (0)44 / 238 83 16
Fax: +380 (0)44 / 238 83 17
e mail: csc-a@csc-a.kiev.ua

EURASIAN REPRESENTATIVE

CONSYS RUSSIA
Promyshlennaya St. 42
RU-198099 St Petersburg
Phone: +7 812 / 325 36 53
Fax: +7 812 / 325 36 53
e mail: consys@consys.spb.ru

ELEKTROSTYLE RUSSIA
ul. Garschina 11
RU-140070 Moscow Oblast
Phone: +7 095 / 557 9756
Fax: +7 095 / 746 8880
e mail: mjuly@elektrostyle.ru

ICOS RUSSIA
Ryazanskij Prospekt, 8A, Office 100
RU-109428 Moscow
Phone: +7 095 / 232 0207
Fax: +7 095 / 232 0327
e mail: mail@icos.ru

STC Drive Technique RUSSIA
Poslannikov per., 9, str.1
RU-107005 Moscow
Phone: +7 095 / 786 21 00
Fax: +7 095 / 786 21 01
e mail: info@privod.ru

MIDDLE EAST REPRESENTATIVE

SHERF Motion Techn. LTD ISRAEL
Rehov Hamerkava 19
IL-58851 Holon
Phone: +972 (0)3 / 559 54 62
Fax: +972 (0)3 / 556 01 82
e mail: —

AFRICAN REPRESENTATIVE

CBI Ltd SOUTH AFRICA
Private Bag 2016
ZA-1600 Isando
Phone: +27 (0)11 / 928 2000
Fax: +27 (0)11 / 392 2354
e mail: cbi@cbi.co.za

AUDIN

Composants & systèmes d'automatisme
7 bis rue de Tinquieux - 51100 Reims - France
Tel. +33(0)326042021 • Fax +33(0)326042820
http://www.audin.fr • e-mail info@audin.fr