



Bonfiglioli

Riduttori

série VF-W

Réducteurs a vis sans fin

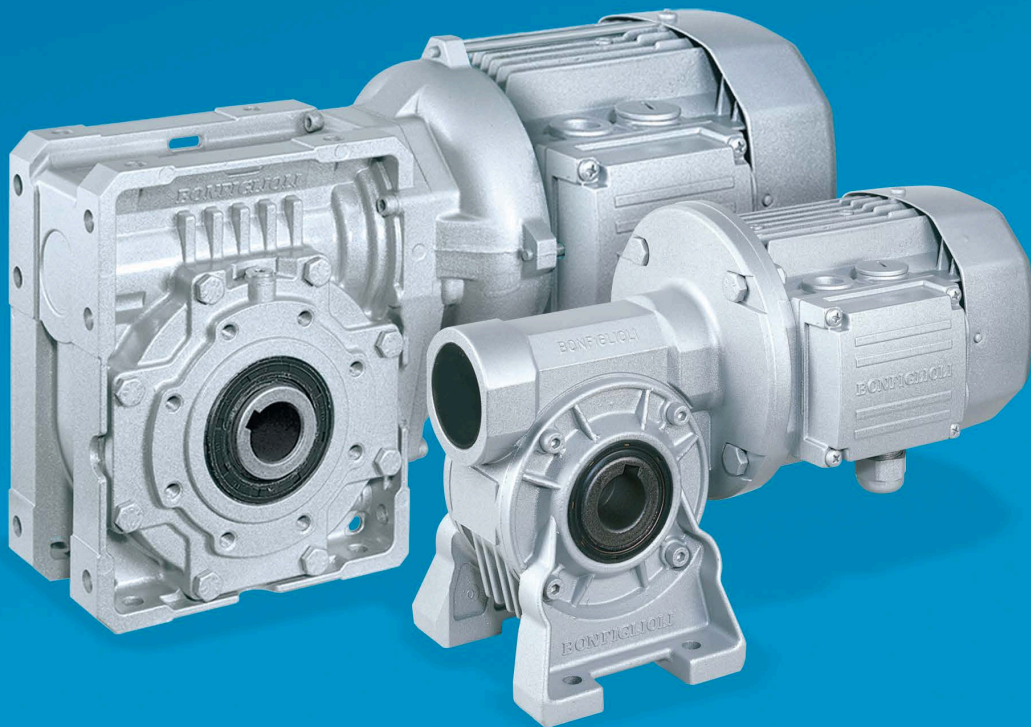

Bonfiglioli

power, control and green solutions



Parag.	Description	Page	Parag.	Description	Page
INFORMATIONS GENERALES			VF-EP / W-EP - RÉDUCTEURS ET MOTORÉDUCTEURS POUR LES ENVIRONNEMENTS CORROSIFS ET ASEPTIQUES		
		2			180
1	Symboles et unités de mesure	2	31	Les avantages de l'exécution EP pour l'industrie alimentaire	180
2	Definitions	3	32	Désignation	182
3	Entretien	6	33	Options réducteurs	184
4	Sélection	6	34	Options moteurs	184
5	Vérifications	9	35	Autres informations concernant les réducteurs et motoréducteurs	185
6	Installation	9	36	Les accessoires de la série EP	185
7	Stockage	11			
8	Conditions de livraison	11			
REDUCTEURS A VIS SANS FIN			DISPOSITIF DE FIN DE COURSE RVS		
		13			187
9	Caractéristiques de construction	13	37	Informations generales	187
10	Formes de construction	14	38	References pour la commande	188
11	Execution de montage	15	39	Désignation	189
12	Désignation	18	40	Tableaux selection motoreducteur	190
13	Options reducteurs	20	41	Dimensions	193
14	Lubrification	23	42	Options	197
15	Positions de montage et orientation boite a borne	24			
16	Charges radiales	33	MOTEURS ELECTRIQUES		
17	Charges axiales	34			198
18	Rendement	37	M1	Symboles et unités de mesure	198
19	Irréversibilité	37	M2	Caractéristiques générales	199
20	Jeux angulaires	39	M3	Caractéristiques mécaniques	204
21	Données techniques motoréducteurs	40	M4	Caractéristiques électriques	206
22	Données techniques réducteurs	71	M5	Moteurs frein asynchrones	213
23	Combinaisons des rapport réducteurs série VF/VF, VF/W, W/VF	93	M6	Moteurs frein en c.c. type BN et M_FD	214
24	Prédispositions moteur	94	M7	Moteurs frein en c.c. type BN et M_AFD	219
25	Moment d'inertie	97	M8	Moteurs frein en c.a. type BN et M_FA	224
26	Dimensions motoréducteur et rëducteur prédisposé pour liaison a moteur IEC	109	M9	Moteurs frein en c.a. type BN_BA	224
27	Dimensions réducteur avec arbre rapide cylindrique	169	M10	Systemes de débloccage frein	230
28	Accessoires	173	M11	Options	232
29	Arbre machine	175	M12	Données techniques des moteurs	245
30	Limiter de couple	176	M13	Dimensions moteurs	261

Révisions

Le sommaire de révision du catalogue est indiqué à la page 272.

Sur le site www.bonfiglioli.com des catalogues avec les dernières révisions sont disponibles.



INFORMATIONS GENERALES

1 SYMBOLES ET UNITES DE MESURE

Symboles	Unités de mesure	Description	Symboles	Unités de mesure	Description
$A_{N 1,2}$	[N]	Charge axiale nominale	$n_{1,2}$	[min ⁻¹]	Vitesse
f_s	–	Facteur de service	$P_{1,2}$	[kW]	Puissance
f_T	–	Facteur thermique	$P_{N 1,2}$	[kW]	Puissance nominale
f_{TP}	–	Facteur de température	$P_{R 1,2}$	[kW]	Puissance nécessaire
i	–	Rapport de réduction	$R_{C 1,2}$	[N]	Charge radiale de calcul
l	–	Rapport d'intermittence	$R_{N 1,2}$	[N]	Charge radiale nominale
J_C	[Kgm ²]	Moment d'inertie de la charge	S	–	Facteur de sécurité
J_M	[Kgm ²]	Moment d'inertie du moteur	t_a	[°C]	Température ambiante
J_R	[Kgm ²]	Moment d'inertie du réducteur	t_f	[min]	Temps de fonctionnement à charge constante
K	–	Facteur d'accélération des masses	t_r	[min]	Temps de repos
K_r	–	Constante de transmission	η_d	–	Rendement dynamique
$M_{1,2}$	[Nm]	Couple	η_s	–	Rendement statique
$M_{c 1,2}$	[Nm]	Couple de calcul			
$M_{n 1,2}$	[Nm]	Couple nominal			
$M_{r 1,2}$	[Nm]	Couple nécessaire			

₁ valeurs pour l'arbre rapide

₂ valeurs pour l'arbre lent



Ce symbole indique des situations de grave danger. Elles ne doivent pas être négligées pour garantir la santé et la sécurité des personnes.



Ce symbole présente les références angulaires pour l'indication de la direction de la charge radiale (l'arbre est vu de face).



Le symbole identifie la page à laquelle l'on peut trouver l'information.



Symbole se référant aux poids des réducteurs et des motoréducteurs. Les valeurs indiquées dans les tableaux des motoréducteurs comprennent tant le poids du moteur à 4 pôles que le poids du lubrifiant contenu, lorsque prévu par BONFIGLIOLI RIDUTTORI.

2 DEFINITIONS

2.1 COUPLE

Couple nominal M_{n2} [Nm]

C'est le couple transmissible en sortie avec une charge continue uniforme se référant à la vitesse en entrée n_1 et à celle correspondante en sortie n_2 . Il est calculé sur la base d'un facteur de service $f_s = 1$.

Couple requis M_{r2} [Nm]

Il représente le couple requis par l'application et devra toujours être inférieur ou égal au couple en sortie nominal M_{n2} du réducteur choisi.

Couple de calcul M_{c2} [Nm]

C'est la valeur de couple à utiliser pour la sélection du réducteur en considérant le couple requis M_{r2} et le facteur de service f_s et s'obtient avec la formule :

$$M_{c2} = M_{r2} \times f_s \leq M_{n2} \quad (1)$$

2.2 PUISSANCE

Puissance en entrée P_{n1} [kW]

Dans les tableaux de sélection des réducteurs, c'est la puissance applicable en entrée se rapportant à la vitesse n_1 et en considérant un facteur de service $F_s = 1$.



2.3 RENDEMENT

Rendement dynamique [η_d]

Il est donné par le rapport entre la puissance en sortie P_2 et celle en entrée P_1 :

$$\eta_d = \frac{P_2}{P_1} \quad (2)$$

En particulier, il est opportun de rappeler que les caractéristiques de couple M_{n2} du catalogue ont été calculées sur la base du rendement dynamique η_d que l'on obtient sur les groupes fonctionnant en régime après rodage. Après une période de rodage on constate également une réduction et finalement la stabilisation de la température de fonctionnement.

La température en charge est influencée par le type de service et par la température ambiante et peut atteindre des valeurs, mesurées sur le carter au niveau de l'axe de la vis sans fin, qui avoisinent 80-100°C, sans que cela porte aucun préjudice à la mécanique du réducteur. S'il y a lieu que la température de fonctionnement puisse atteindre la limite supérieure – dans l'ordre de 90-100°C – il est conseillé d'équiper le réducteur de bagues d'étanchéité en Elastomère fluoré, en rappelant sur la commande l'option **PV**.

Rendement statique [η_s]

C'est le rendement que l'on obtient au démarrage du réducteur et, s'il peut être négligé pour les réducteurs à engrenages, il doit être pris en considération dans le choix des motorisations avec réducteurs à vis sans fin destinés aux applications caractérisées par un type de service intermittent (ex. Levages).

2.4 RAPPORT DE REDUCTION [i]

Le rapport de réduction est identifiée par la lettre [i] et son calcul s'effectue à partir de la vitesse d'entrée n_1 et de la vitesse de sortie n_2 en utilisant la relation suivante :

$$i = \frac{n_1}{n_2} \quad (3)$$

2.5 MOMENT D'INERTIE J_r [kgm²]

Les moments d'inertie indiqués dans le catalogue se réfèrent à l'axe d'entrée du réducteur par conséquent, dans le cas d'accouplement direct, ils se rapportent déjà à la vitesse du Moteur.



2.6 FACTEUR DE SERVICE [f_s]

Le facteur de service est le paramètre qui traduit en une valeur numérique la difficulté du service que le réducteur est appelé à effectuer en tenant compte, avec une approximation inévitable, du fonctionnement journalier, de la variabilité de la charge et des éventuelles surcharges liées à l'application spécifique du réducteur.

Sur le graphique ci-dessous, le facteur de service peut être trouvé, après avoir sélectionné la colonne relative aux heures de fonctionnement journalier, à l'intersection entre le nombre de démarrages horaires et l'une des courbes K1, K2 et K3.

Les courbes K_ sont associées à la nature du service (approximativement : uniforme, moyen et difficile) au moyen du facteur d'accélération des masses K, lié au rapport entre les inerties des masses conduites et le moteur.

Indépendamment de la valeur du facteur de service ainsi trouvée, nous signalons qu'il existe des applications parmi lesquelles, à titre d'exemple, les levages, pour lesquels la rupture d'un organe du réducteur pourrait exposer le personne opérant à proximité immédiate à des risques de lésion.

En cas de doute concernant les risques éventuels de l'application, nous vous conseillons de contacter préalablement notre Service Technique.

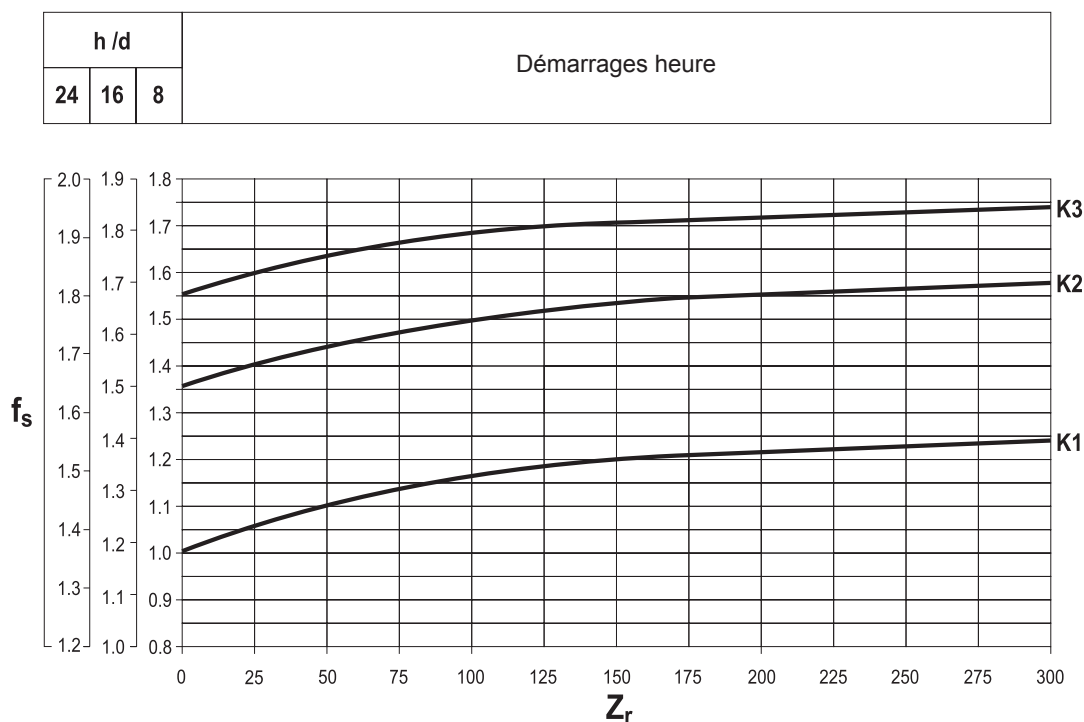

Facteur d'accélération des masses, [K]

Le paramètre sert à sélectionner la courbe relative au type de charge particulier. La valeur est obtenue par l'équation :

$$K = \frac{J_c}{J_m} \quad (4)$$



$$K = \frac{J_c}{J_m} \rightarrow$$

J_c = Moment of inertia of driven masses referred to motor drive shaft

J_m = Motor moment of inertia

$K \leq 0,25$	→ K1	Uniform load
$0,25 < K \leq 3$	→ K2	Moderate shock load
$3 < K \leq 10$	→ K3	Heavy shock load
$K > 10$	→	nous vous conseillons de contacter notre Service Technique

3 ENTRETIEN

Les réducteurs fournis avec lubrification permanente n'ont besoin d'aucun remplacement périodique de huile. Pour les autres, nous conseillons d'effectuer une première vidange du lubrifiant après les 300 premières heures de fonctionnement en réalisant un lavage soigné à l'intérieur du groupe avec des produits détergents appropriés. Eviter de mélanger les huiles à base minérale avec des huiles synthétiques. Contrôler périodiquement le niveau du lubrifiant en effectuant les vidanges conformément aux intervalles indiqués dans le tableau.

Température huile [°C]	Intervalle de lubrification [h]	
	huile minérale	huile synthétique
< 65	8000	25000
65 - 80	4000	15000
80 - 95	2000	12500

4 SELECTION

4.1 Sélection des motoréducteurs

- Déterminez le facteur de service f_s comme autrefois indiqué.
- Déterminez la puissance requise à l'entrée du réducteur

$$P_{r1} = \frac{M_{r2} \times n_2}{9550 \times \eta_d} \quad [\text{kW}] \quad (5)$$

- Rechercher parmi les tableaux données techniques motoréducteurs celui correspondant à une puissance P_n :

$$P_n \geq P_{r1} \quad (6)$$



Sauf indication contraire la puissance P_n des moteurs indiquée dans le catalogue se réfère à un service continu S1.

Pour les moteurs utilisés dans des conditions différentes du service S1, il sera nécessaire d'identifier le type de service prévu en se référant aux normes CEI 2-3/IEC 34-1. En particulier, pour les services de type S2 à S8 ou pour les tailles de moteurs égales ou inférieures à 132 il est possible d'obtenir une majoration de la puissance par rapport à celle prévue pour le service continu. Par conséquent, la condition à satisfaire sera :

$$P_n \geq \frac{P_{r1}}{f_m} \quad (7)$$

Le facteur de majoration f_m peut être obtenu en consultant le tableau Suivante.

Rapport d'intermittence

$$I = \frac{t_f}{t_f + t_r} \times 100 \quad (8)$$

t_f = temps de fonctionnement à charge constante

t_r = temps de repos

	SERVICE						Nous contacter
	S2			S3*			
	Durée du cycle [min]			Rapport d'intermittence (I)			
	10	30	60	25%	40%	60%	
f_m	1.35	1.15	1.05	1.25	1.15	1.1	

* La durée du cycle devra être égale ou inférieure à 10 minutes. Si supérieure, contacter notre Service Technique.

Dans la section relative à la puissance installée P_n sélectionner enfin le motoréducteur qui développe la vitesse de fonctionnement la plus proche à la vitesse n_2 désirée et pour lequel le facteur de sécurité S soit pareil, ou supérieur, au facteur de service f_s .

$$S \geq f_s \quad (9)$$

Le facteur de sécurité est défini ainsi :

$$S = \frac{M_{n2}}{M_2} = \frac{P_{n1}}{P_1} \quad (10)$$



Dans les tableaux de sélection des motoréducteurs les accouplements sont développés avec moteurs à 2, 4 et 6 poles alimentés à 50 Hz. Pour vitesses de commande différentes à celles- ci, sélectionner suite aux données nominales fournies par les réducteurs.

4.2 Sélection des réducteurs

a) Déterminer le facteur de service f_s .

b) Procédez à la définition du couple de calcul :

$$M_{c2} = M_{r2} \times f_s \quad (11)$$

c) Calculez le rapport de réduction :

$$i = \frac{n_1}{n_2} \quad (12)$$

d) Dans le chapitre « Données techniques réducteurs » sélectionner la taille qui, pour la vitesse d'entrée n_1 et pour le rapport $[i]$ est la plus proche, et offre un couple nominal satisfaisant à la condition suivante :

$$M_{n2} \geq M_{c2} \quad (13)$$

Vérifier la possible adaptation du moteur électrique en consultant le tableau des prédispositions possibles.



5 VERIFICATIONS

Une fois effectuée la sélection du réducteur, ou motoréducteur, il faut procéder aux suivantes Vérifications :

a) Couple maximum

Généralement, le couple maximum (à considérer comme une pointe de charge instantanée) applicable au réducteur ne doit pas dépasser les 300% du couple nominal M_{n2} . Vérifier par conséquent que cette limite ne soit pas dépassée en adoptant, si nécessaire, des dispositifs adaptés pour limiter le couple. Pour les moteurs triphasés à double polarité, il est nécessaire de prêter une attention particulière au couple de commutation instantané qui est généré lors du passage de la grande à la petite vitesse étant donné qu'il peut être considérablement plus élevé que le couple maximum lui-même. Une méthode simple et économique pour réduire ce couple consiste à alimenter seulement deux phases du moteur pendant la commutation (la durée d'alimentation sur deux phases peut être réglée au moyen d'un relais temporisateur) :

Couple de commutation	
$Mg_2 = 0.5 \times Mg_3$	
Mg_2	Couple de commutation en alimentant deux phases
Mg_3	Couple de commutation en alimentant trois phases

b) Charges radiales

Vérifier que les charges radiales agissant sur les arbres d'entrée et/ou de sortie se situent dans les valeurs de catalogue admises. Si elles sont supérieures, choisir la taille du réducteur supérieure ou modifier la reprise de charge. Rappelons que toutes les valeurs indiquées dans le catalogue se réfèrent à des charges agissant au milieu de la longueur disponible de l'arbre contrôlé. Par conséquent, en phase de vérification, il est indispensable de prendre en considération cette condition en déterminant, si nécessaire, avec les formules appropriées, la charge admissible à la distance x désirée. Se rapporter à ce propos aux paragraphes relatifs aux charges Radiales.

c) Charges axiales

Les éventuelles charges axiales devront être comparées avec les valeurs admissibles.

Si l'on est en présence de charges axiales très élevées ou combinées avec des charges radiales, nous conseillons d'interpeller notre Service Technique.

d) Démarrages/heure

Pour les services différents de S1, avec un nombre important d'insertions/heure, il faudra prendre en considération un facteur Z (déterminé à l'aide des informations reportées dans le chapitre des moteurs) qui définit le nombre maximum de démarrages spécifique pour l'application concernée.

6 INSTALLATION

6.1 Instructions générales

a) S'assurer que la fixation du réducteur soit stable afin d'éviter toute vibration.

En cas de chocs, de surcharges prolongées ou de blocages installer des coupleurs hydrauliques, des embrayages, des limiteurs de couple etc...



- b) En phase de peinture, il faudra protéger les plans usinés et le bord extérieur des bagues d'étanchéité pour éviter que la peinture ne dessèche le caoutchouc, ce qui risque de nuire à l'efficacité du joint.
- c) Les organes qui sont calés sur les arbres de sortie du réducteur doivent être réalisés avec une tolérance ISO H7 pour éviter les accouplements trop serrés qui, en phase de montage, pourraient endommager irrémédiablement le réducteur. En outre, pour le montage et le démontage de ces organes, nous conseillons d'utiliser un outillage et des extracteurs appropriés en utilisant le trou taraudé situé en extrémité d'arbre.
- d) Les surfaces de contact devront être propres et traitées avec des produits de protections appropriés avant le montage afin d'éviter l'oxydation et par suite le blocage des pièces.
- e) Avant la mise en service du réducteur, vérifier que la machine où il est monté est conforme aux normes de la Directive Machines 2006/42/CE et ses mises à jour.
- f) Avant la mise en marche de la machine, s'assurer que la position du niveau du lubrifiant soit conforme à la position de montage du réducteur et que la viscosité soit appropriée.
- g) En cas d'installation en plein air, il est nécessaire d'appliquer des protections et/ou des caches appropriés de façon à éviter l'exposition directe aux agents atmosphériques et aux rayonnements solaires.

6.2 Mise en service des réducteurs série W

Les groupes W63, W75 et W86 sont fournis avec un couvercle latéral orientable, équipé d'un bouchon fermé pour le transport.

Avant la mise en service de l'appareil, celui-ci doit être remplacé par le reniflard fourni avec chaque unité. Voir la figure :

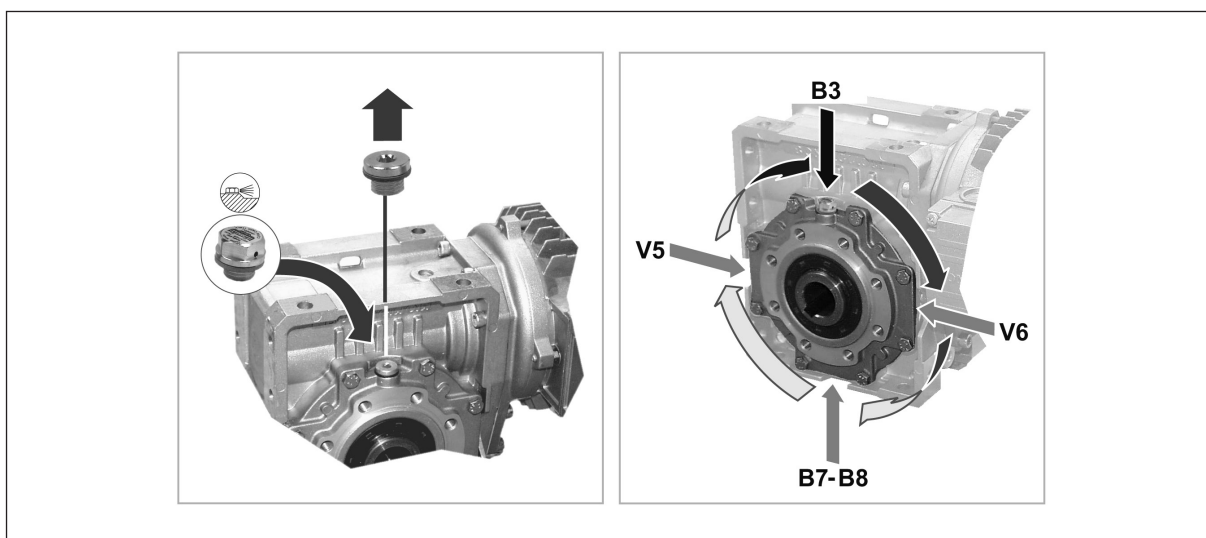

En revanche, en ce qui concerne l'orientation B6, le bouchon fermé NE doit PAS être remplacé par le bouchon de purge.



7 STOCKAGE

Un correct stockage des produits nécessite de respecter les règles suivantes:

- a) Exclure les zones à ciel ouvert, les zones exposées aux intempéries ou avec humidité Excessive.
- b) Interposer dans tous les cas entre le plancher et les produits des planches de bois ou des supports d'autre nature empêchant le contact direct avec le sol.
- c) Pour une stockage de long durée il faut protéger les surfaces d'accouplement (brides, arbres, manchon d'accouplement) avec produit anti oxydant (Mobilarma 248 ou equivalent).
Dans ce cas les réducteurs devront être placés avec bouchon reniflard vers le haut et complètement repli d'huile.
Avant de la mise en service du réducteur, la bon quantité d'huile devra être rétabli selon la quantité indiqué sur le catalogue.

8 CONDITIONS DE LIVRAISON

Les réducteurs sont livrés comme suit :

- a) déjà prédisposés pour être installés dans la position de montage comme défini en phase de commande ;
- b) testés selon les spécifications internes ;
- c) les surfaces de liaison ne sont pas peintes ;
- d) équipés d'écrous et de boulons pour le montage des moteurs normalisés pour la version IEC ;
- e) embouts de protections en plastique sur les arbres ;
- f) dotés d'un crochet de levage (quand cela est prévu).

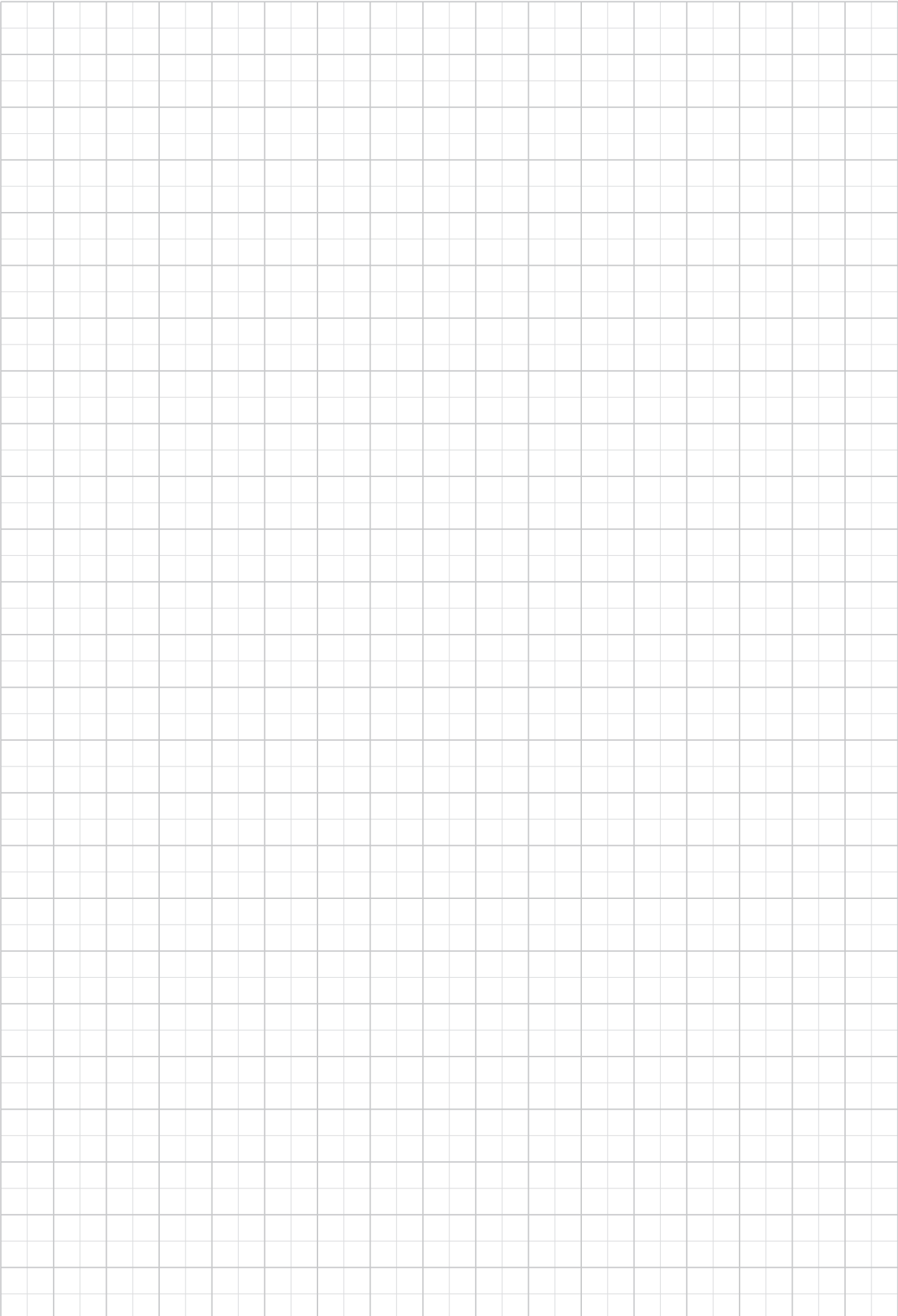

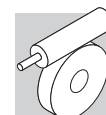

REDUCTEURS A VIS SANS FIN

9 CARACTERISTIQUES DE CONSTRUCTION

9.1 Les principales caractéristiques des réducteurs à roue et vis sans fin Bonfiglioli

- Arbre lent creux symétrique pour une fixation aisée sur chaque face du réducteur, ainsi que pour les arbres lents rapportés (disponibles comme accessoires).
- La rectification de la vis sans fin et les usinages de précision autorisent des rendements élevés ainsi qu'un grand silence de fonctionnement.
- Nombreuses possibilités de fixation du réducteur comme la configuration à pattes, à bride ou pendulaire (bras de réaction en option).
- Possibilité de personnalisation étendue grâce à la liste d'options disponibles.

9.2 Les caractéristiques spécifiques aux groupes du type VF

- Carters en aluminium moulé sous pression pour les VF27, VF30, VF44 e VF49. Carters en fonte pour les VF130 à VF250. Ces derniers sont recouverts d'une peinture epoxy thermodurcissable

9.3 Les caractéristiques spécifiques aux groupes du type W

- Carter monobloc en Aluminium.
- Grande versatilité et flexibilité d'utilisation, permises par la forme cubique et par les nombreuses surfaces usinées pour la fixation du réducteur, et des accessoires.
- La configuration avec moteur intégré est particulièrement compacte, légère et économique.
- La bague à lèvres de l'arbre rapide des groupes W63, W75 et W86 est en position interne, et est faite en Elastomère fluoré afin d'améliorer les conditions de fonctionnement et la durée de vie.

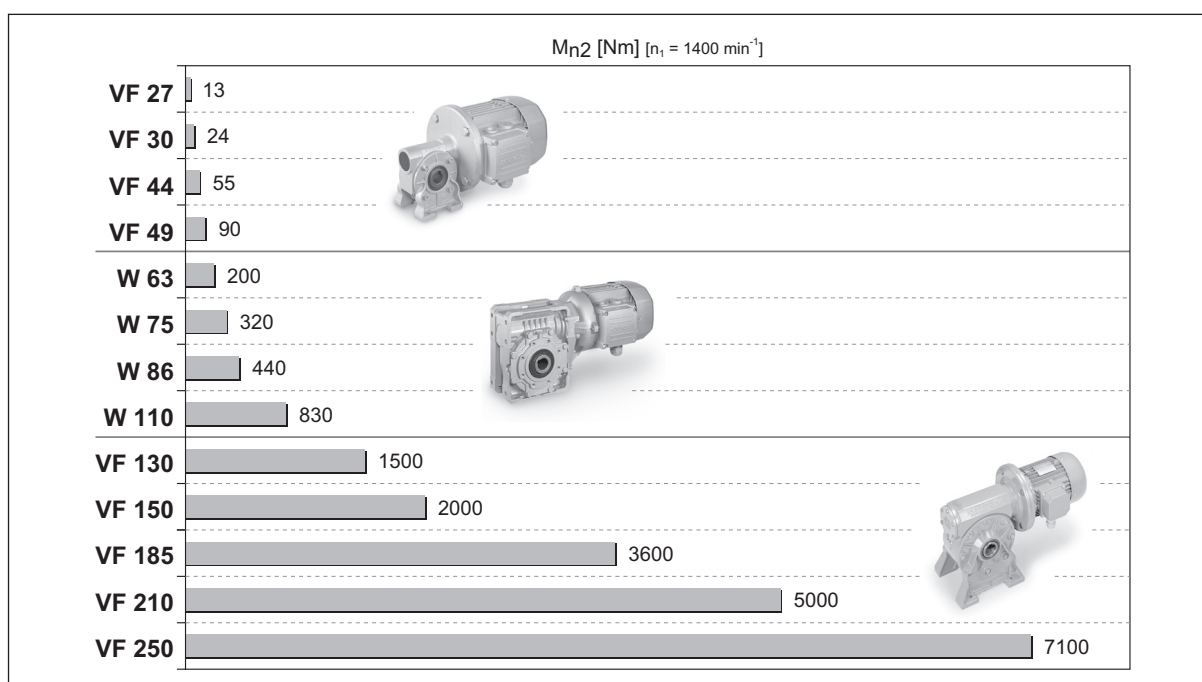

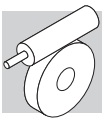

10 FORMES DE CONSTRUCTION

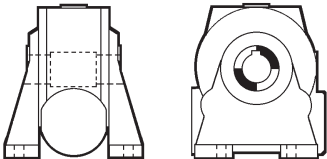
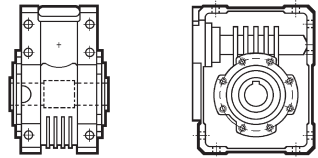
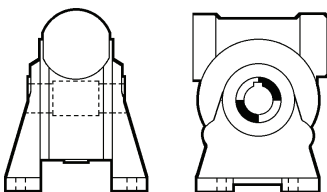
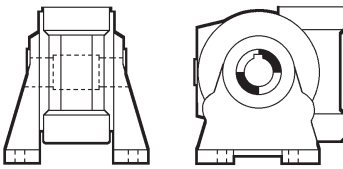
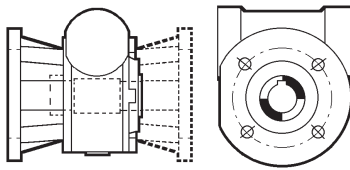
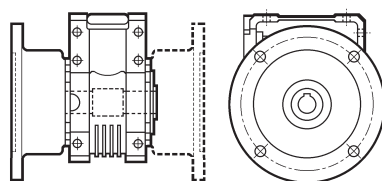
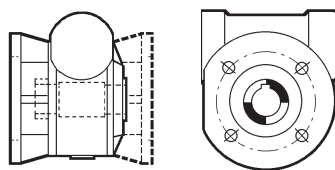
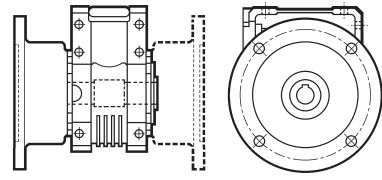
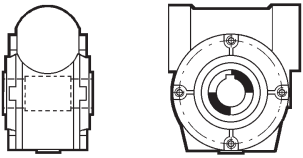
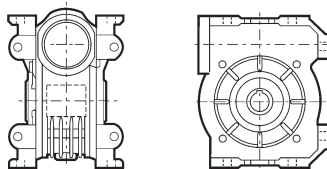
VF_	W_
 <p>N VF 27 ... VF 250 Pattes et vis horizontale en bas</p>	 <p>U W 63 ... W 110 Carter universel</p>
 <p>A VF 27 ... VF 250 Pattes et vis horizontale en haut</p>	
 <p>V VF 27 ... VF 250 Pattes et vis verticale</p>	
 <p>F VF 27 ... VF 185 Bride standard</p> <p>FA VF 44 ... VF 49 Bride haute</p> <p>F 1 F 2 FA 1 FA 2</p>	 <p>UF W 63 ... W 110 Bride standard</p> <p>UF 1 UF 2</p>
 <p>FC VF 130 ... VF 185 Bride courte</p> <p>FR VF 130 ... VF 185 Bride courte et roulements renforcés</p> <p>FC 1 FC 2 FR 1 FR 2</p>	 <p>UFC W 63 ... W 110 Bride reduit en longueur</p> <p>UFCR W 75 Bride reduit en longueur et diametre</p> <p>UFC 1 UFC 2 UFCR 1 UFCR 2</p>
 <p>P VF 30 ... VF 250 Bride pendulaire</p> <p>P1 = P2 VF 30 ... VF 49 VF 210, VF 250</p> <p>P 1 P 2 (VF 30...VF 250) (VF 130...VF 185)</p>	
 <p>U VF 30 ... VF 49 Carter à pattes monobloc</p>	

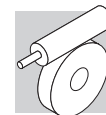

11 EXECUTION DE MONTAGE

Les réducteurs combinés, si rien n'est spécifié lors de la commande, seront configurés suivant l'exécution de montage en gris dans les tableaux ci-dessous.

	CW1	CCW1	CW2	CCW2	CW3	CCW3	CW4	CCW4
U								
UF_ UFC_ UFR1_								
N								
A								
V								
F1 FA1 FC1 FR1								
F2 FA2 FC2 FR2								
P1								
P2								

Couvercle pour fixation pendulaire

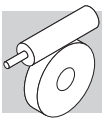

Dans la configuration HS (réducteur, il est possible d'obtenir toutes les exécutions de montage présentées.

Dans la configuration P (IEC), certaines exécutions de montage ne peuvent être obtenues qu'en utilisant des brides CEI (B5 ou B14) de taille inférieure ou égale aux tailles indiquées dans le tableau suivante.

		CW1 CCW1	CW2 CCW2	CW3	CCW3	CW4 CCW4
VF/VF30/44	A, N, V, P1	63B14	63B14	63B14	63B14	63B14
	F-FA					
VF/VF30/49	A, N, V, P1	63B14	63B14	63B14	63B14	63B14
	F-FA					
VF/W30/63	U	63B5-63B14	63B5-63B14	63B5-63B14	63B5-63B14	63B5-63B14
	UF-UFC					
VF/W44/75	U	71B5-71B14	71B5-71B14	71B5-71B14	71B5-71B14	71B5-71B14
	UF-UFC-UFCR					
VF/W44/86	U	71B5-71B14	71B5-71B14	71B5-71B14	71B5-71B14	71B5-71B14
	UF-UFC					
VF/W49/110	U	80B5-80B14	80B5-80B14	80B5-80B14	80B5-80B14	80B5-80B14
	UF-UFC					
W/VF63/130	N	71B5-90B14	90B5-90B14	71B5-90B14	71B5-90B14	71B5-90B14
	A	90B5-90B14	71B5-90B14	90B5-90B14	90B5-90B14	90B5-90B14
	V		90B5-90B14			—
	F1	90B5-90B14	71B5-90B14	90B5-90B14	71B5-90B14	90B5-90B14
	FC1-FR1				90B5-90B14	
	P1				90B5-90B14	
	F2	90B5-90B14	71B5-90B14	71B5-90B14	90B5-90B14	90B5-90B14
	FC2-FR2			90B5-90B14		
P2	90B5-90B14					
W/VF86/150	N	112B5-112B14	112B5-112B14	71B5-112B14	71B5-112B14	71B5-112B14
	A	112B5-112B14	90B5-112B14	112B5-112B14	112B5-112B14	112B5-112B14
	V	112B5-90B14	112B5-90B14			71B5-112B14
	F1	112B5-112B14	71B5-90B14	112B5-112B14	71B5-90B14	112B5-112B14
	FC1-FR1		90B5-112B14		112B5-112B14	
	P1		90B5-112B14		112B5-112B14	
	F2	112B5-112B14	71B5-90B14	71B5-90B14	112B5-112B14	112B5-112B14
	FC2-FR2		90B5-112B14	112B5-112B14		
P2	90B5-112B14		112B5-112B14			
W/VF86/185	N	112B5-112B14	112B5-112B14	90B5-112B14	90B5-112B14	90B5-112B14
	A	90B5-112B14	112B5-112B14	112B5-112B14	112B5-112B14	112B5-112B14
	V	112B5-90B14				90B5-112B14
	F1	112B5-112B14	90B5-112B14	112B5-112B14	90B5-112B14	112B5-112B14
	FC1-FR1				112B5-112B14	
	P1				112B5-112B14	
	F2	112B5-112B14	90B5-112B14	90B5-112B14	112B5-112B14	112B5-112B14
	FC2-FR2			112B5-112B14		
P2	112B5-112B14					
VF/VF130/210	N	#	132B5	#	#	#
	A	132B5	#	132B5	132B5	132B5
	V					
	P					
VF/VF130/250	N	#	132B5	#	#	#
	A	132B5	#	132B5	132B5	132B5
	V		132B5			
	P		#			

Consulter notre Service Technico-Commercial

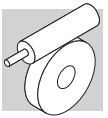

11.1 Orientation boîte à bornes

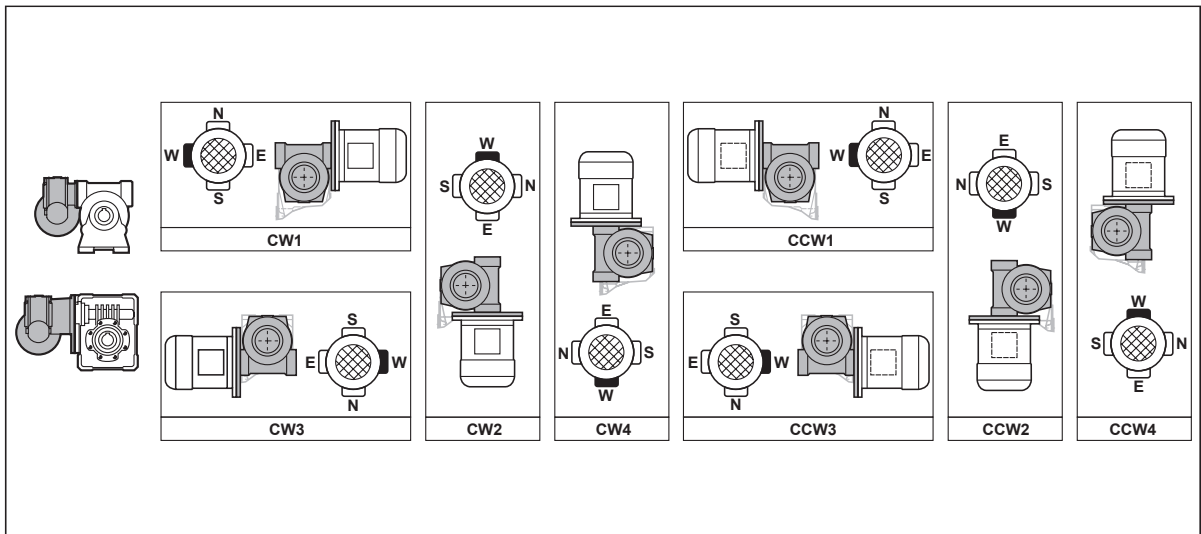

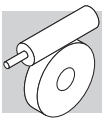

12 DÉSIGNATION

REDUCTEUR

W 63 L1 UF1 — 24 S2 — B3

OPTIONS

20

ASSEMBLAGE

VF/VF, VF/W, W/VF	CW (1, 2, 3, 4) CCW (1, 2, 3, 4)
-------------------	---

15

POSITION DE MONTAGE

VF 27...VF 49 VFR 44, VFR 49	B3
W, WR VF 130...VF 250 VFR 130...VFR 250	B3 (default), B6, B7, B8, V5, V6
VF/VF VF/W W/VF	B3 (default), B6, B7, B8, V5, V6

24

FORME DE CONSTRUCTION DU MOTEUR

B5	(VF 30...VF 250, VFR 49...VFR 250, W, WR)
B14	(VF 30...VF 49, W)

94
95

DESIGNATION ENTREE

	VF	VFR	W	WR	VF/VF	VF/W	W/VF
P(IEC)	 P27 (VF 27 only), P56...P225	 P63, P80...P160	 P71...P132	 P63...P112	 P56, P63, P90...P132	 P56...P80	 P71...P112
S_		 S44 (VFR 44 only)	 S1...S3				 S1...S3
HS							

94
95

95

169
172

RAPPORT DE REDUCTION

DIAMETRE ARBRE LENT

W 75 VF/W 44/75	D30 (default), D28 (sur demande)
--------------------	---

FORME DE CONSTRUCTION

14

LIMITEUR DE COUPLE

VF, VFR W, WR	L1, L2	VF/VF	LF
------------------	---------------	-------	-----------

176

TAILLE REDUCTEUR

VF	27, 30, 44, 49, 130, 150, 185, 210, 250	VF/VF	30/44, 30/49, 130/210, 130/250
VFR	44, 49, 130, 150, 185, 210, 250	VF/W	30/63, 44/75, 44/86, 49/110
W, WR	63, 75, 86, 110	W/VF	63/130, 86/150, 86/185

TYPE REDUCTEU

VF, W	Réducteur a vis sans fin
VFR, WR	Réducteur avec pré-étage
VF/VF, VF/W, W/VF	Réducteur combiné

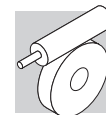

MOTEUR

FREIN

BN 63A 4 230/400-50 IP54 CLF W FD 3.5 R SB 220 SA

OPTIONS

ALIMENTATION
FREIN



TYPE REDRESSEUR
AC/DC
NB, SB, NBR, SBR



LEVIER DE DEBLOCAGE FREIN
R, RM



COUPLE FREIN

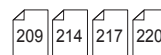

TYPE DE FREIN
FD, AFD (frein c.c.)
FA, BA (frein c.a.)

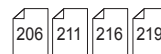

POSITION BOITE A BORNES
W (default), **N, E, S**



FORME DE CONSTRUCTION
— (moteur compact)
B5, B14 (moteur IEC)

CLASSE ISOLATION
CL F standard
CL H option



DEGRE DE PROTECTION
IP55 standard (IP54 - moteur frein)



TENSION - FREQUENCE



Nbre POLES
2, 4, 6, 2/4, 2/6, 2/8, 2/12, 4/6, 4/8

TAILLE MOTEUR
1SC ... 3LB (moteur compact)
56A ... 225M (moteur IEC) BN 27, BN 44 (moteurs speciaux)

TYPE MOTEUR
M = 3 phase compact
BN = 3 phase IEC

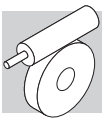

13 OPTIONS REDUCTEURS

SO

Les réducteurs VF 30 ... VF 49, W 63 ... W 86, habituellement fourni avec lubrifiant, sont livrés sans huile.

LO

Les réducteurs VF 130...VF 250 et W 110, habituellement dépourvus de lubrifiants, sont demandés avec huile synthétique du type couramment utilisé par BONFIGLIOLI RIDUTTORI et remplis conformément à la position de montage demandée.

L'applicabilité de l'option LO est décrite dans le tableau suivant.

	LO					
	Position de montage					
	B3	B6	B7	B8	V5	V6
W 110 U-UF-UFC	X	X	X	X	●	●
VF 130 A-N-P-F-FC	X	X	X	X	●	●
VF 130 V	●	X	X	●	X	X
VF 130 FR	X	●	●	X	●	●
VF 150 A-N-P-F-FC	X	X	X	X	●	●
VF 150 V	●	X	X	●	X	X
VF 150 FR	X	●	●	X	●	●
VF 185 A-N-P-F-FC	X	X	X	X	●	●
VF 185 V	●	X	X	●	X	X
VF 185 FR	X	●	●	X	●	●
VF 210 A-N-P	X	●	●	X	●	●
VF 210 V	●	●	●	●	X	X
VF 250 A-N-P	X	●	●	X	●	●
VF 250 V	●	●	●	●	X	X

RB

Vis saillante sur le côté opposé commande (sauf VF 27).

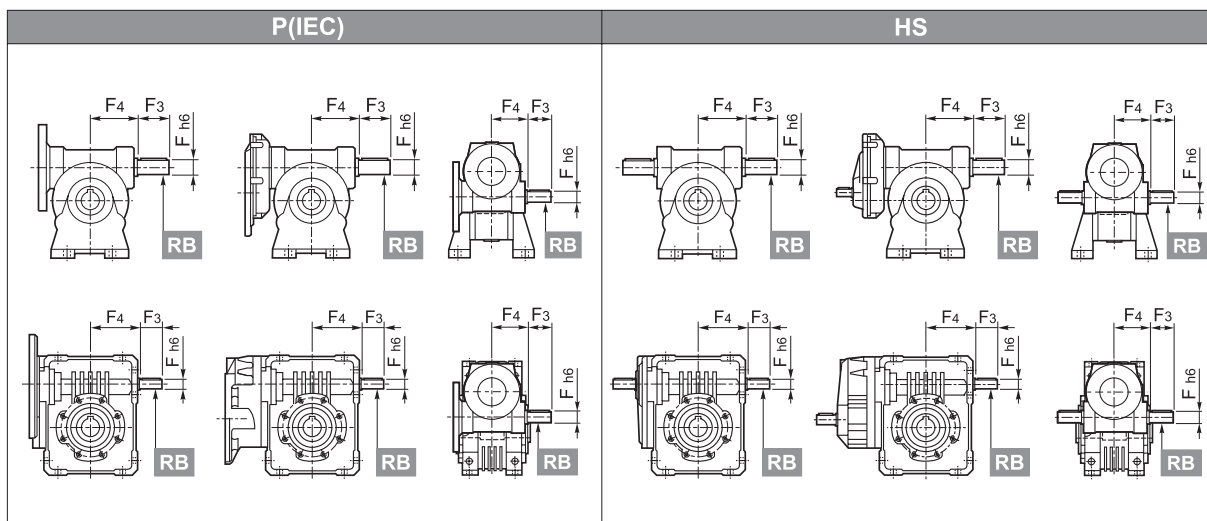

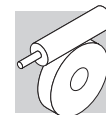

RBO

Vis saillante sur le 2ème réducteur (seulement pour les exécutions combinées).

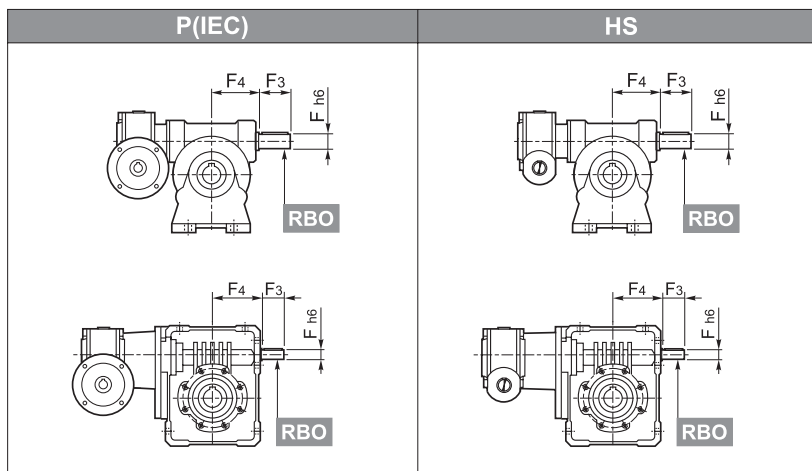

Dimensions arbre sortant (options RB et RBO)								
		F	F1	F2	F3	F4	V	
	VF	30	9	10.2	3	20	—	
	VFR	44	11	12.5	4	30	—	
	VF/VF	49	16	18	5	40	M6	
	W	63	18	20.5	6	40	74	M6
		75	19	21.5	6	40	88.5	M6
		WR	86	25	28	8	50	101.5
	VF/W	110	25	28	8	60	127.5	M8
		130	30	33	8	60	160	M8
	VF	150	35	38	10	65	185	M8
		VFR	185	40	43	12	70	214.5
W/VF		210	48	51.5	14	82	185	M16x40
	250	55	59	16	82	228	M16x40	

Sur les projets **A** et **P** on monte d'habitude les ventilateurs de refroidissement qui n'est pas prévue avec l'option **RB**.

VV

Bague d'étanchéité en Elastomère fluoré sur arbre rapide. Disponible pour W110 et pour groupes VF, a l'exclusion de VF 30 avec option RB et VF 30_HS.

PV

Les réducteurs sont équipées de bagues d'étanchéité en Elastomère fluoré soit sur l'arbre de sortie que sur l'arbre d'entrée, a l'exclusion de VF 30 avec option RB et VF 30_HS.

KA

Kit pieds pour interchangeabilité avec groupe équivalent type VF_A.

KV

Kit pieds pour interchangeabilité avec groupe équivalent type VF_V (a l'exclusion de W avec option RB).

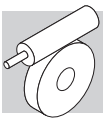

AO

Arbre coté opposé par rapport au standard (VF 27).

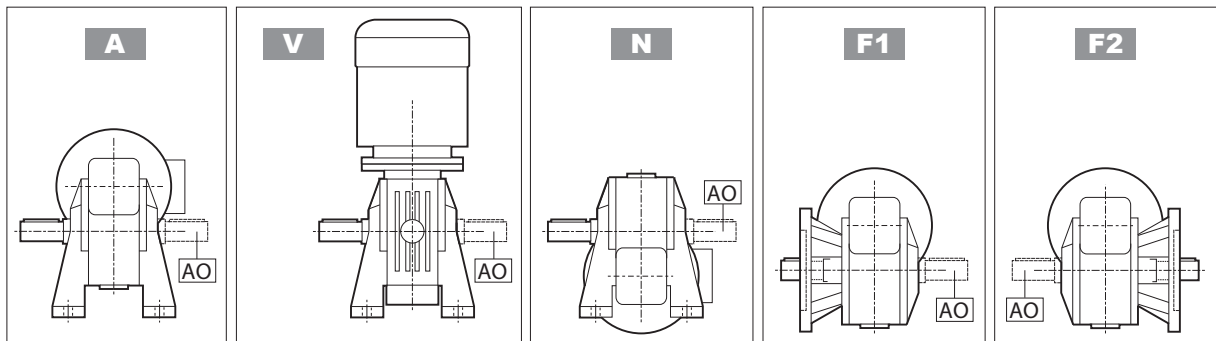

PROTECTION DE SURFACE

Lorsque qu'aucune classe de protection n'est requise, les surfaces (ferreuses) des réducteurs fournissent une protection minimale de classe C2 (UNI EN ISO 12944-2). Afin d'améliorer la résistance à la corrosion atmosphérique, les réducteurs peuvent être fournis avec une protection de surface **C3** et **C4**, obtenue par recouvrement complet.

PROTECTION DE SURFACE	Environnements typiques	Température maximum de surface	Classe de corrosivité en accord avec UNI EN ISO 12944-2
C3	Environnement urbains et industriels avec jusqu'à 100% d'humidité relative (pollution de l'air moyenne)	120°C	C3
C4	Zones industrielles, zones côtières, usines chimiques, avec jusqu'à 100% d'humidité relative (pollution de l'air élevée)	120°C	C4

Les réducteurs avec une protection optionnelle en classes **C3** ou **C4** sont disponibles dans plusieurs teintes. Si aucune teinte spécifique n'est requise (voir l'option "PEINTURE"), les réducteurs seront réalisés en RAL 7042. Les réducteurs peuvent également être fournis avec une protection de surface pour une corrosivité en classe **C5** en accord avec UNI EN ISO 12944-2. Contacter notre Service Technique pour plus de détails.

PEINTURE

Les réducteurs avec une protection optionnelle en classe C3 ou C4 sont disponibles dans les teintes indiquées dans la table suivante.

PEINTURE	Couleur	RAL numéro
RAL7042*	Gris trafic A	7042
RAL5010	Bleu gentiane	5010
RAL9005	Noir foncé	9005
RAL9006	Aluminium blanc	9006
RAL9010	Blanc pur	9010

* Les réducteurs sont fournis dans cette teinte standard si rien n'est spécifié.

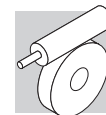

NOTE – Les options “PEINTURE” peuvent seulement être spécifiées en accord avec les options “PROTECTION DE SURFACE”.

PREUVES DOCUMENTAIRES

AC - Certificat de conformité

Document dont la délivrance atteste de la conformité du produit à la commande et de la construction de celui-ci conformément aux procédures standard de traitement et de contrôle prévues par le système de Qualité Bonfiglioli Riduttori.

CC - Certificat de réception

La spécification implique la réalisation de vérifications de conformité à la commande, des contrôles visuels généraux et des vérifications instrumentales des dimensions d'accouplement. En outre, des contrôles généraux de fonctionnement à vide et des vérifications de la fonctionnalité des joints d'étanchéité sont réalisés en modalité statique et en fonctionnement. La vérification s'applique à un échantillon statistique du lot d'expédition.

Options moteurs

Pour plus d'informations sur les options, consulter les chapitres correspondants dans la section Moteurs électriques.

14 LUBRIFICATION

14.1 Lubrification réducteurs serie W et VF

Les groupes VF 27 ... VF 49, W 63 ... W 86 sont normalement livrés par l'usine, ou par le réseau de vente officiel, avec une charge de lubrifiant synthétique. Sur demande les mêmes réducteurs peuvent être fournis sans lubrifiant, en spécifiant l'option SO. L'applicabilité de l'option est décrite dans le chapitre « OPTIONS REDUCTEURS ».

Les groupes VF 130 ... VF 250 et W 110 sont normalement fournis sans lubrifiant, le remplissage précédent la mise en service sera à la charge de l'utilisateur. En précisant l'option LO lors de la commande, ces groupes seront remplis d'huile synthétique en usine, avec la quantité correspondant à la position de montage. L'applicabilité de l'option est décrite dans le chapitre « OPTIONS REDUCTEURS ».

Les réducteurs combinés séries VF/VF, VF/W et W/VF sont constitués de deux unités dont la lubrification est distincte.

Pour les tableaux de référence pour le placement des bouchons de service et la quantité de lubrifiant, se référer au Manuel d'Installation, Utilisation et Entretien (disponible sur www.bonfiglioli.com).

Le lubrifiant “long life” ; fourni de série est de nature synthétique et, à moins de contamination par l'extérieur, il ne demande pas des remplacements périodiques pour toute la durée de vie du réducteur. Le même lubrifiant permet de fonctionner à des températures ambiantes $0 \leq t_a \leq 50$ °C.

Le fonctionnement des réducteurs est admis pour des températures ambiantes comprises entre -20°C et +40°C.

Pour des températures ambiantes comprises entre -20°C et -10°C le démarrage du réducteur est admis seulement après un préchauffage progressif et homogène, ou avec un fonctionnement « à vide », sans charge appliquée. La charge pourra être ensuite appliquée à l'arbre du réducteur quand celui-ci aura atteint une température de -10°C, ou supérieure.

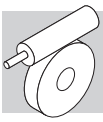

14.2 Type de lubrifiant

Enfin, si le lubrifiant utilisé n'est pas de type SHELL comme conseillé, Bonfiglioli recommande qu'il soit de composition équivalente du point de vue de la nature synthétique et de la viscosité, de plus, il doit comporter des additifs anti-mousse.

Pour le tableau des lubrifiants recommandés/permis, se référer au Manuel d'Installation, Utilisation et Entretien (disponible sur www.bonfiglioli.com).

			Position de montage	
			B3 - B6 - B7 - B8 - V5	V6
	Précouple hélicoïdal	WR 63...WR 86	OMALA S4 WE 320	GADUS S5 V142W 00
		VFR 44...VFR 250 WR 110	OMALA S4 WE 320	
	Réducteurs à vis sans fin	W 63...W 110 VF 44...VF 250	OMALA S4 WE 320	
	Réducteur avec limiteur de couple	W 63...W 110 VF 44...VF 49	OMALA S4 WE 460	

15 POSITIONS DE MONTAGE ET ORIENTATION BOITE A BORNE

Les orientations des boîtes à bornes des moteurs sont définies en regardant le moteur du côté ventilateur. L'orientation standard est indiquée en noir (W).

Les positions de la boîte à bornes ne sont pas valables pour VFR 44. Se reporter à la page 19 et aux pages 114-115 pour la désignation et l'identification de la forme de construction.

Position angulaire levier déblocage frein.

Dans les moteurs freins, ce levier (si requis) aura l'orientation standard de 90° par rapport à la boîte à bornes (position AB); spécifier avec options relatives si l'orientation désirée est différente.

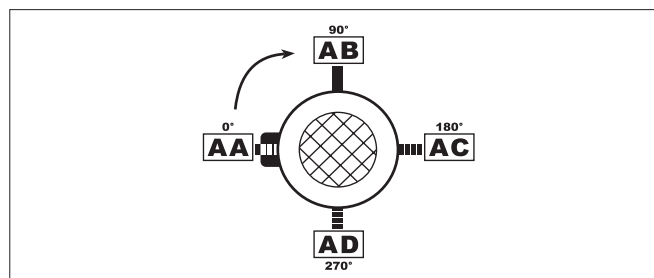

Dans les pages suivantes sont décrites les positions de montage des réducteurs de type VF et W.

Pour les réducteurs combinés de type VF/VF, VF/W et W/VF, les positions de montage se réfèrent au second réducteur (côté machine) ; pour le premier réducteur (côté entrée), consulter le chapitre « Exécution du montage ».

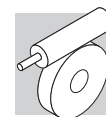

VF 27 _ ... VF 49 _

VFR 44 _ , VFR 49 _

_HS

_S - _P (IEC)

	_HS			_S - _P (IEC)			
A	B3	B7	V5				← VF
	B6	B8	V6				← VFR
N	B3	B7	V5				← VF
	B6	B8	V6				← VFR
V	B3	B7	V5	← VF	← VF		← VFR
	B6	B8	V6	← VFR			
P	B3	B7	V5				← VF
	B6	B8	V6				← VFR
F	B3	B7	V5				← VF
	B6	B8	V6				← VFR
U	B3	B7	V5				← VF
	B6	B8	V6				← VFR

Position de montage de base.

Les réducteurs sont marqués exclusivement dans la position de montage de base (B3) mais ils peuvent être installés également dans des positions dérivées (B6, B7, B8, V5, V6). Après l'installation, la position de montage ne peut pas être modifiée

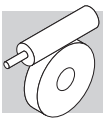

W 63 U ... W 110 U

WR 63 U ... WR 110 U

_HS

_S - _P (IEC)

B3

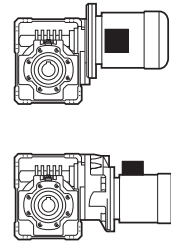
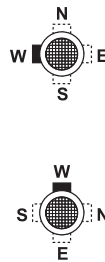
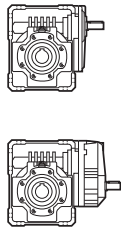
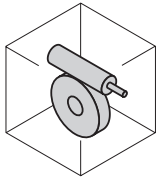

B6

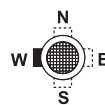
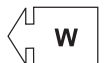
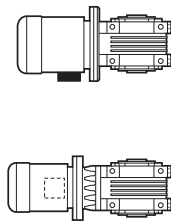
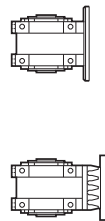
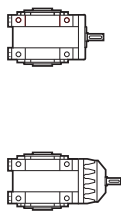
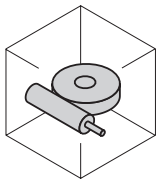

B7

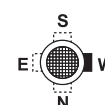
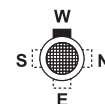
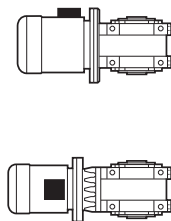
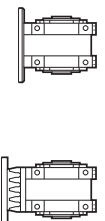
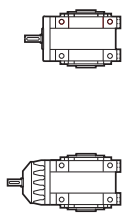
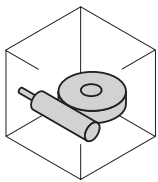

B8

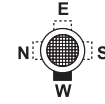
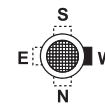
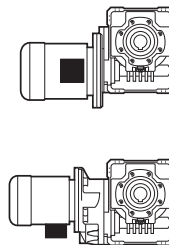
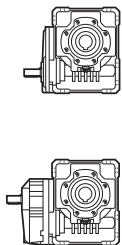
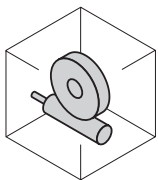

V5

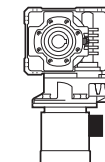
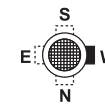
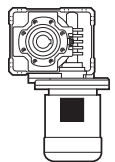
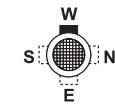
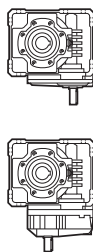
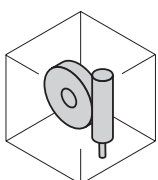

V6

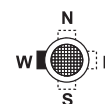
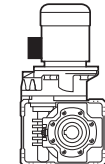
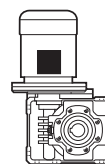
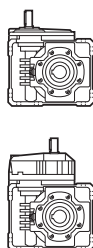
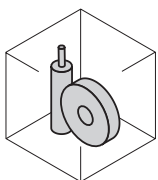

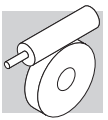

W 63 UF/UFC ... W 110 UF/UFC WR 63 UF/UFC ... WR 110 UF/UFC

_HS

_S - _P (IEC)

B3

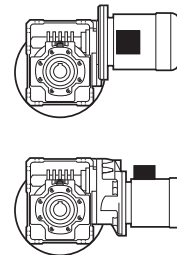
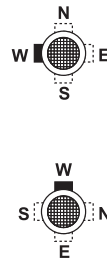
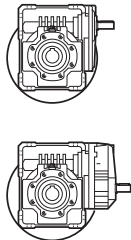
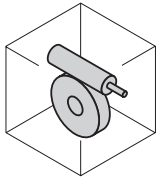

B6

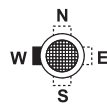
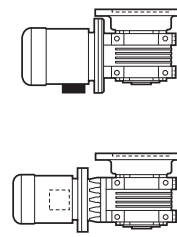
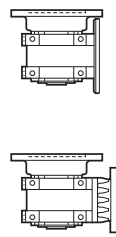
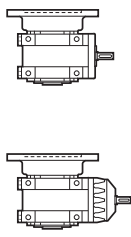
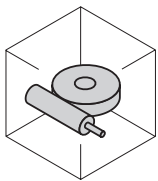

B7

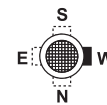
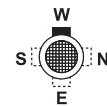
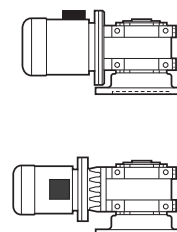
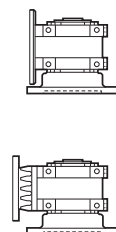
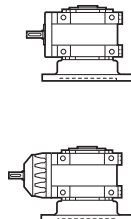
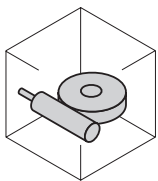

B8

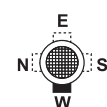
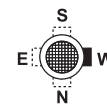
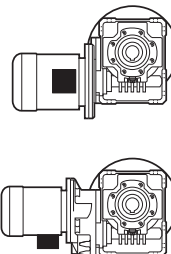
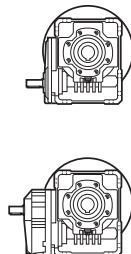
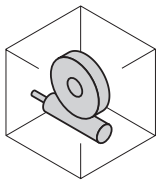

V5

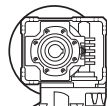
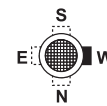
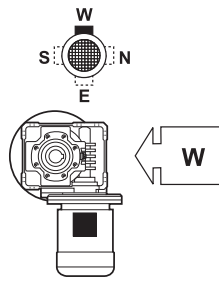
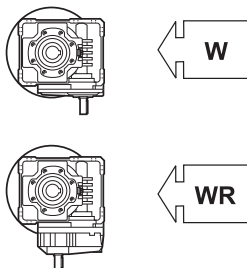
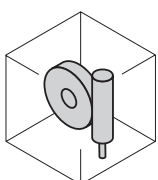

V6

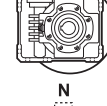
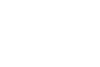
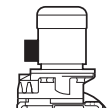
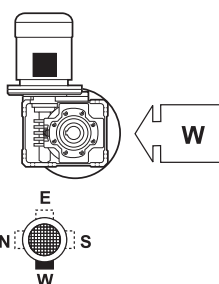
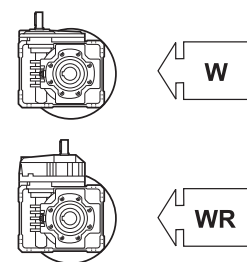
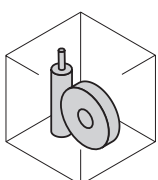

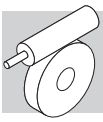

VF 130 A ... VF 250 A

VFR 130 A ... VFR 250 A

_HS

_P (IEC)

B3

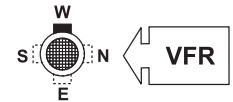
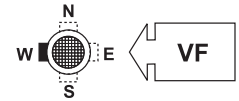
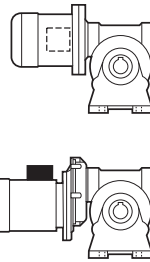
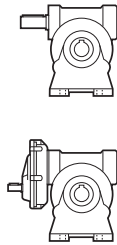
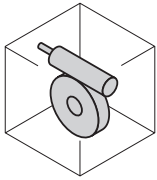

B6

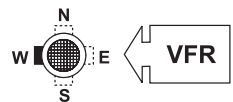
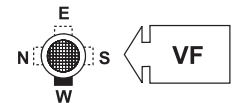
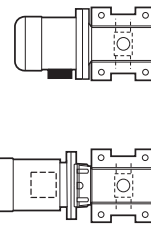
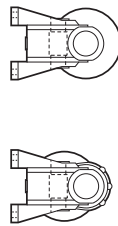
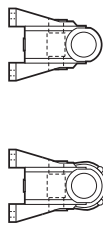
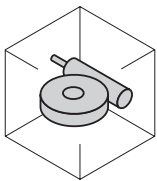

B7

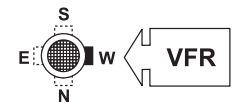
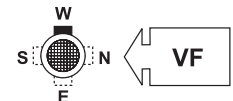
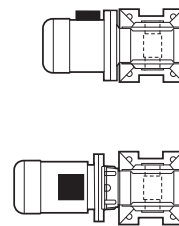
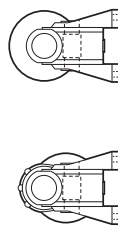
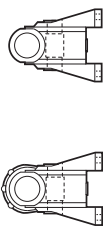
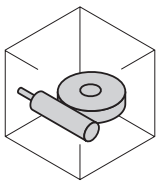

B8

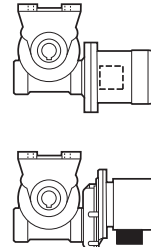
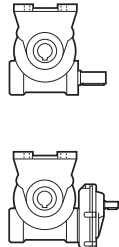
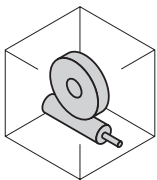

V5

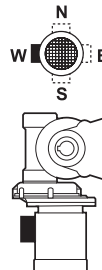
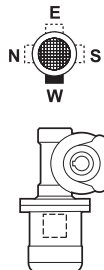
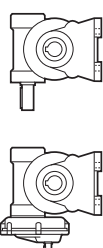
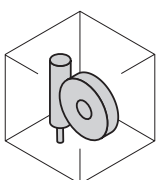

V6

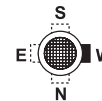
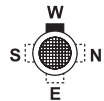
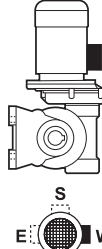
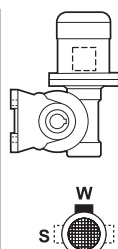
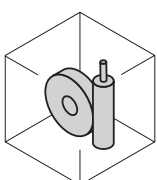

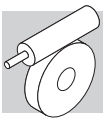

VF 130 N ... VF 250 N VFR 130 N ... VFR 250 N

	_HS		_P (IEC)	
B3				
B6				
B7				
B8				
V5		 	 	
V6		 	 	

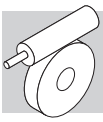

VF 130 V ... VF 250 V

VFR 130 V ... VFR 250 V

_HS

_P (IEC)

B3

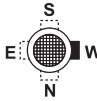
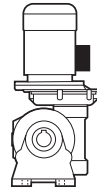
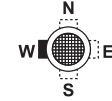
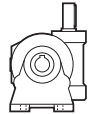
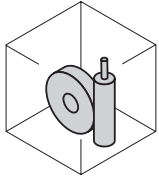

B6

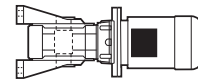
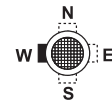
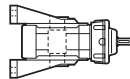
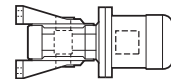
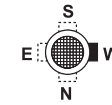
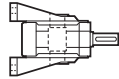
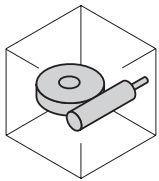

B7

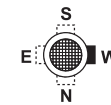
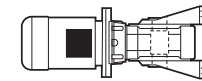
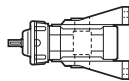
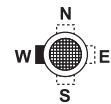
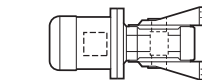
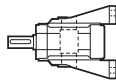
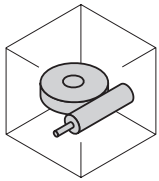

B8

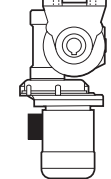
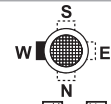
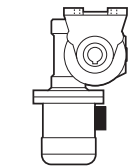
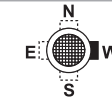
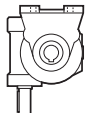
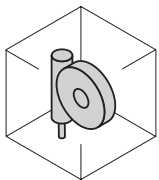

V5

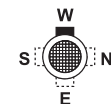
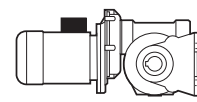
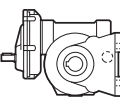
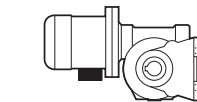
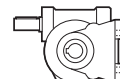
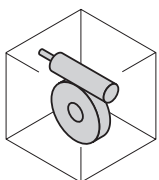

V6

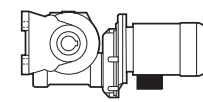
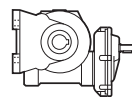
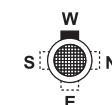
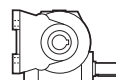
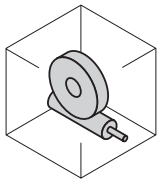

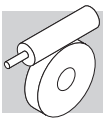

VF 130 P ... VF 250 P VFR 130 P ... VFR 250 P

_HS

_P (IEC)

B3

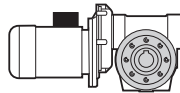
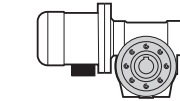
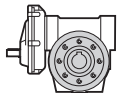
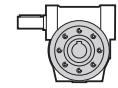
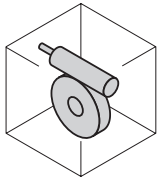

B6

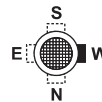
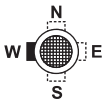
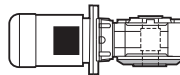
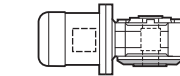
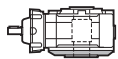
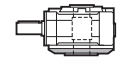
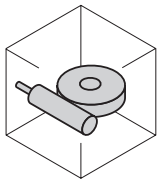

B7

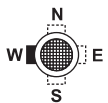
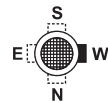
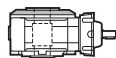
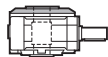
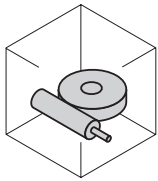

B8

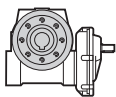
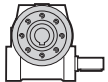
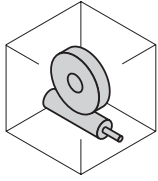

V5

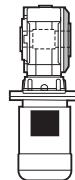
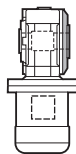
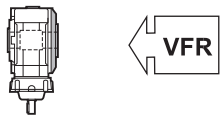
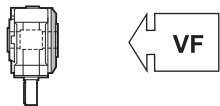
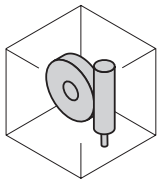

V6

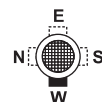
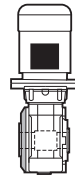
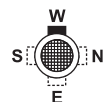
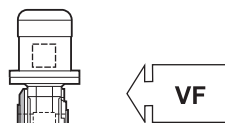
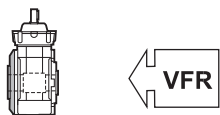
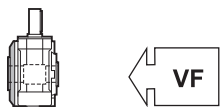
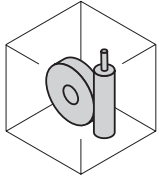

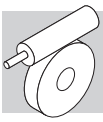

VF 130 F ... VF 250 F

VFR 130 F ... VFR 250 F

_HS

_P (IEC)

B3

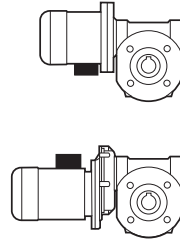
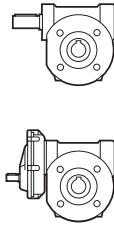
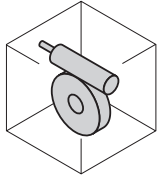

B6

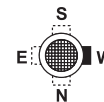
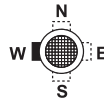
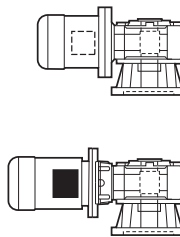
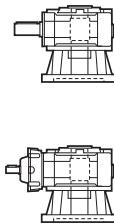
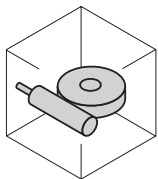

B7

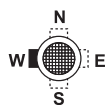
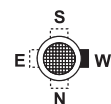
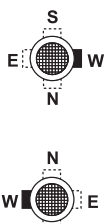
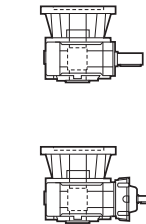
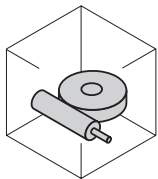

B8

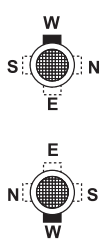
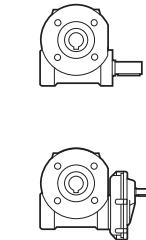
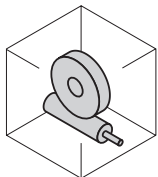

V5

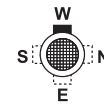
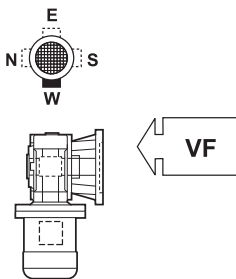
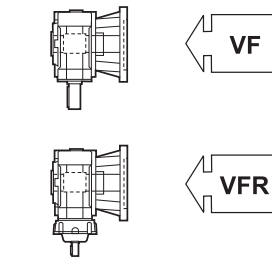
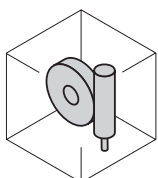

V6

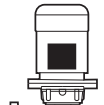
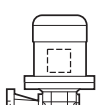
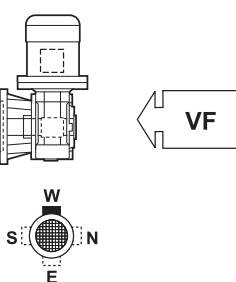
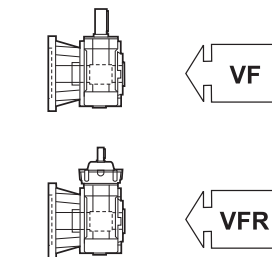
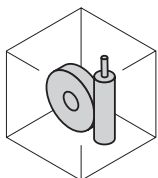

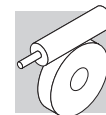

16 CHARGES RADIALES

16.1 Calcul de la force résultant

Les organes de transmission calés sur les arbres d'entrée et/ou de sortie du réducteur génèrent des forces dont la résultante agit sur l'arbre dans le sens radial.

L'entité de ces charges doit être compatible avec la capacité d'endurance du système arbre-roulements du réducteur.

Plus particulièrement, la valeur absolue de la charge appliquée (R_{c1} pour l'arbre d'entrée, R_{c2} pour l'arbre de sortie) doit être inférieure à la valeur nominale (R_{n1} pour l'arbre d'entrée, R_{n2} pour l'arbre de sortie) indiquée dans les tableaux des données techniques.

Dans les formules qui suivent, l'indice (1) se réfère à des tailles relatives à l'arbre rapide, l'indice (2) concerne l'arbre lent.

La charge générée par une transmission extérieure peut être calculée, avec une bonne approximation, au moyen de la formule suivante:

$$R_c = \frac{2000 \times M \times K_r}{d}$$

$K_r = 1$		M [Nm]	
$K_r = 1.25$		d [mm]	
$K_r = 1.5 - 2.0$			

16.2 Vérification de la charge axiale

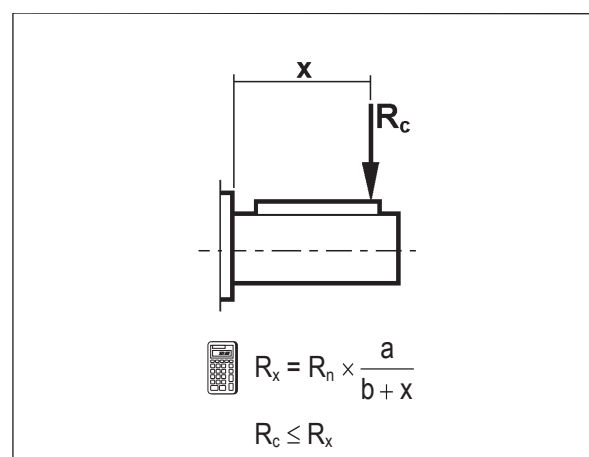
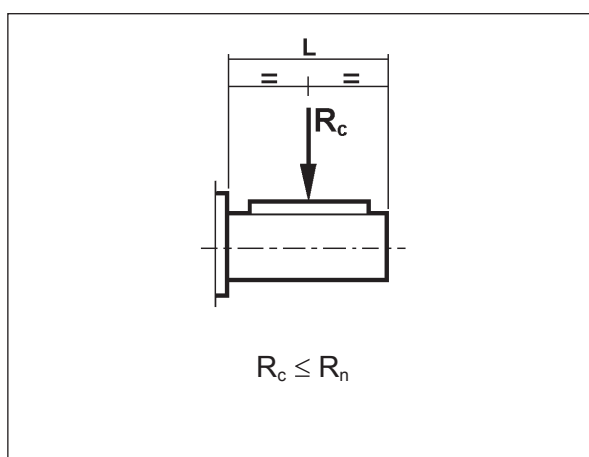

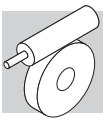

16.3 Constantes du réducteur

	Arbre lent		$R_{n2} \text{ max}$ [N]
	a	b	
VF 27	56	44	600
VF 30	60	45	1700
VF 44 - VFR 44 - VF/VF 30/44	71	51	2500
VF 49 - VFR 49 - VF/VF 30/49	99	69	3450
W 63 - WR 63 - VF/W 30/63	132	102	5000
W 75 - WR 75 - VF/W 44/75	139	109	6200
W 86 - WR 86 - VF/W 44/86	149	119	7000
W 110 - WR 110 - VF/W 49/110	173	136	8000
VF 130 - VFR 130 - W/VF 63/130	182	142	13800
VF 150 - VFR 150 - W/VF 86/150	198	155	16000
VF 185 - VFR 185 - W/VF 86/185	220	170	19500
VF 210 - VFR 210 - W/VF 130/210	268	203	34500
VF 250 - VFR 250 - W/VF 130/250	334	252	52000

17 CHARGES AXIALES

Les valeurs de charge axiale admissible sur les arbres rapides $[A_{n1}]$ et lent $[A_{n2}]$ peuvent être calculées, en se référant à la valeur de charge radiale correspondante $[R_{n1}]$ et $[R_{n2}]$ au moyen des formules suivantes :

$$\begin{aligned} A_{n1} &= R_{n1} \times 0,2 \\ A_{n2} &= R_{n2} \times 0,2 \end{aligned} \quad (14)$$

Les valeurs de charge axiale admissible ainsi calculées se réfèrent au cas de forces axiales agissant en même temps que les charges radiales nominales. Dans le seul cas la valeur de la charge radiale agissant sur l'arbre soit nul, l'on peut considérer la charge axiale admissible $[A_n]$ égale à 50% de la valeur de la charge radiale admissible $[R_n]$ sur le même arbre. En présence de charges axiales excédant la valeur admissible, ou de forces axiales fortement supérieures aux charges radiales, il est conseillé de contacter le Service Technique Bonfiglioli Riduttori pour une vérification.

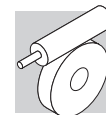

17.1 Charges axiales maximales admises dans la version FR

Pour les applications nécessitant des charges axiales très élevées, nous fournissons la version FR dans les tailles 130, 150, 185. Cette version, dont les dimensions externes sont identiques à celles de la version FC, peut supporter les charges axiales (considérablement supérieures aux charges admises par les versions standard) indiquées dans le tableau suivant se référant au rapport de transmission [i] et au sens de rotation +/- de l'arbre de sortie.

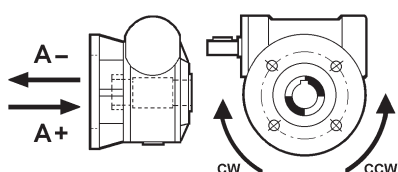

A+ = Charge axiale en compression

A- = Charge axiale en traction

CW = Rotation horaire

CCW = Rotation anti-horaire

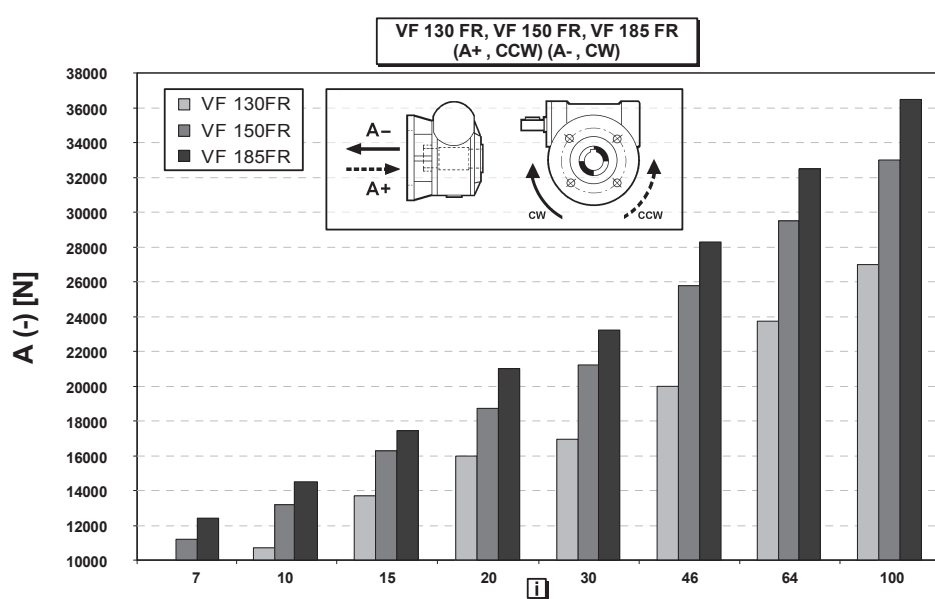
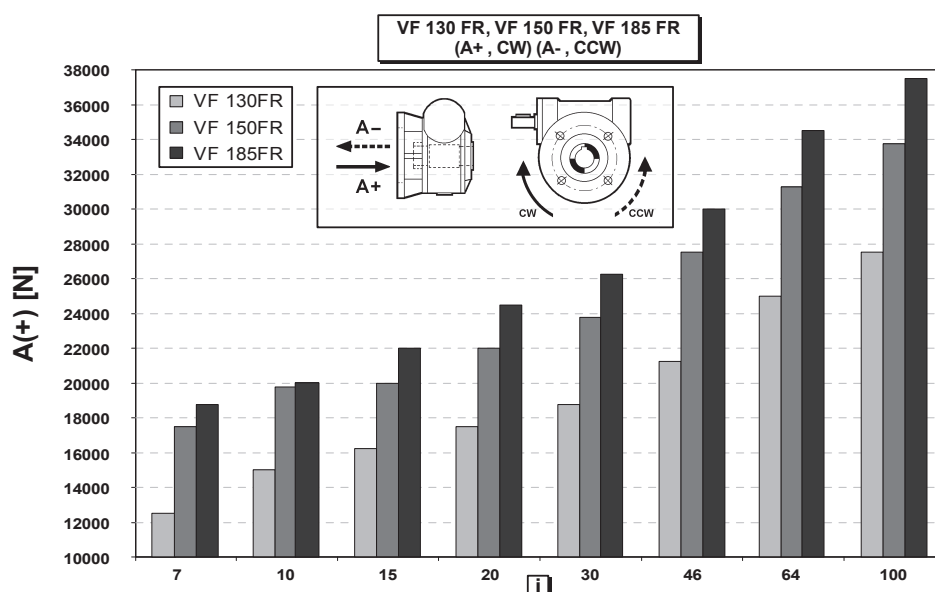

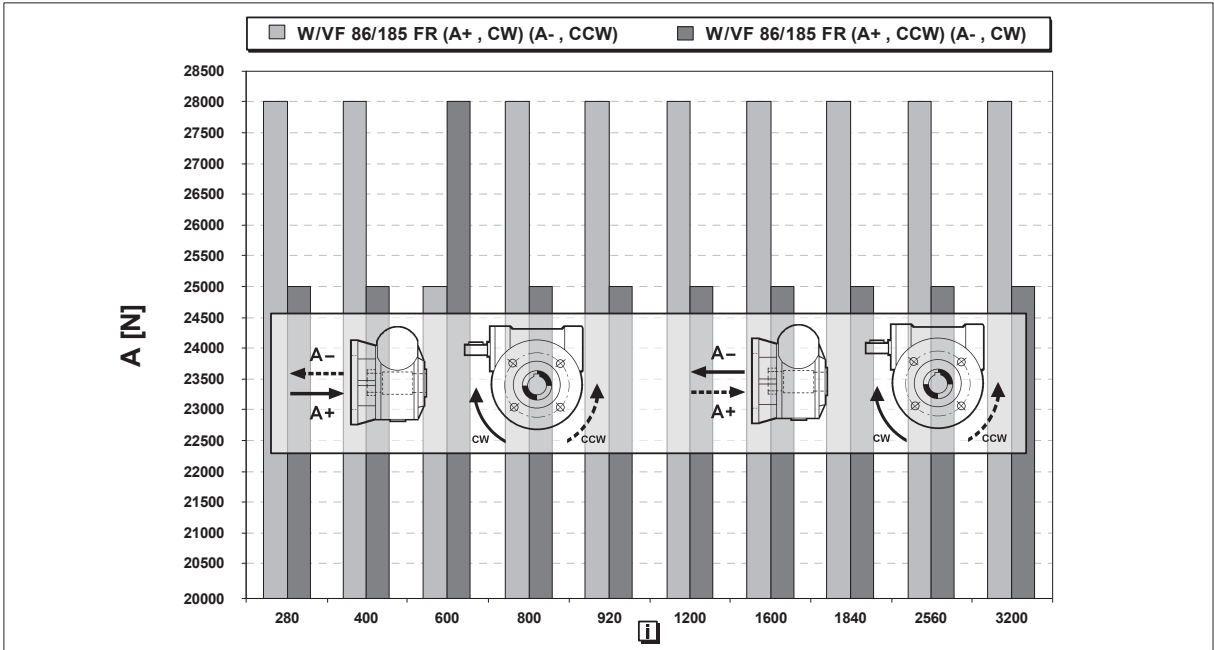
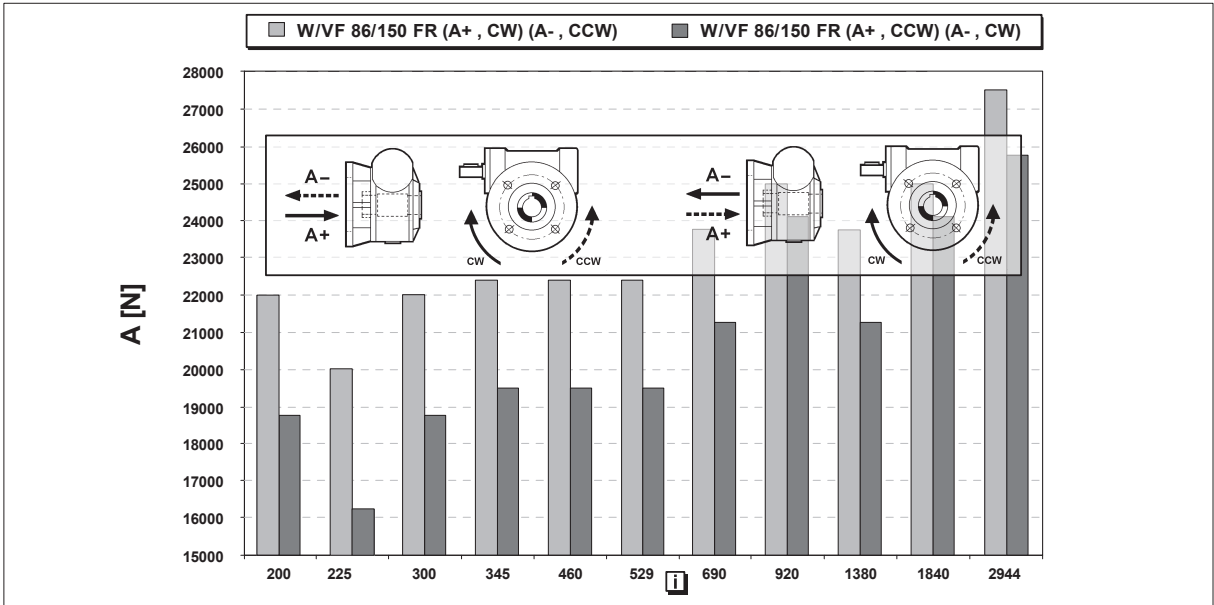
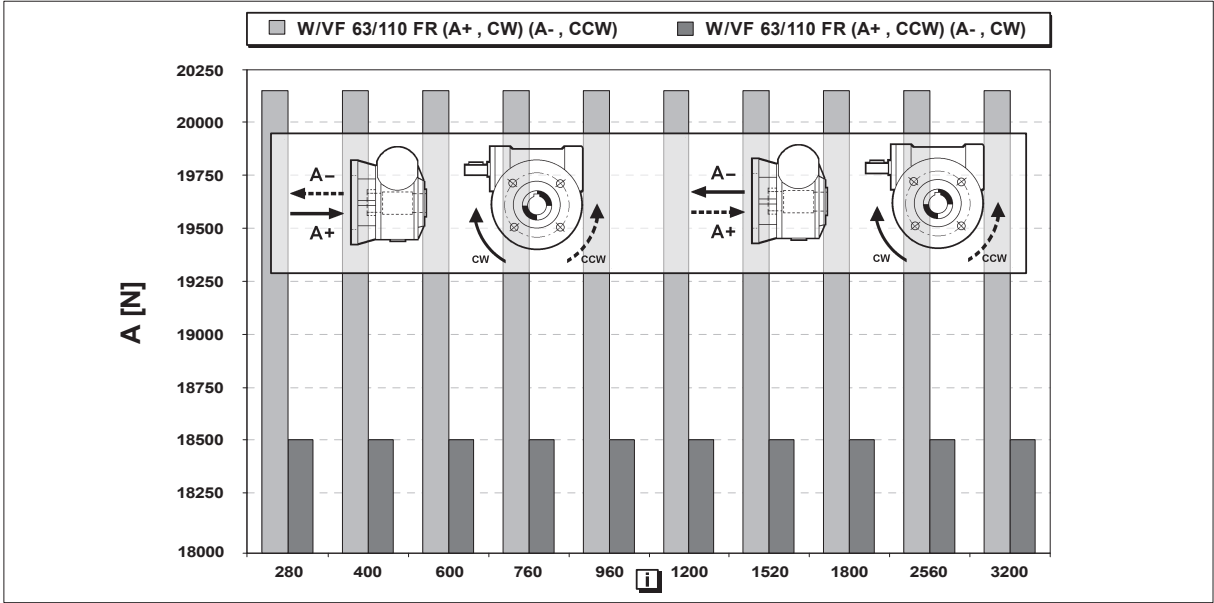
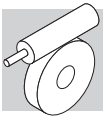

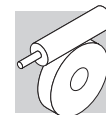

18 RENDEMENT

Le rendement $[\eta]$ dépend des paramètres suivants :

- angle d'hélice de l'engrenage
- vitesse d'entrée
- rodage de l'engrenage

Rappelons à ce sujet que la valeur optimale se manifeste au bout de quelques heures de rodage et est atteinte ensuite sur les réducteurs fonctionnant à plein régime de la façon indiquée dans le tableau suivante, si bien que pour les applications prévoyant un service intermittent (levage, actionnement etc.), il faut augmenter de façon appropriée la puissance du moteur, afin de compenser le faible rendement du réducteur au démarrage.

Les valeurs de couple M_{n2} indiquées dans le catalogue sont calculées en tenant compte du rendement des réducteurs à régime hd.

Le tableau fournit, à titre indicatif, le temps nécessaire pour atteindre la valeur maximum de rendement dynamique.

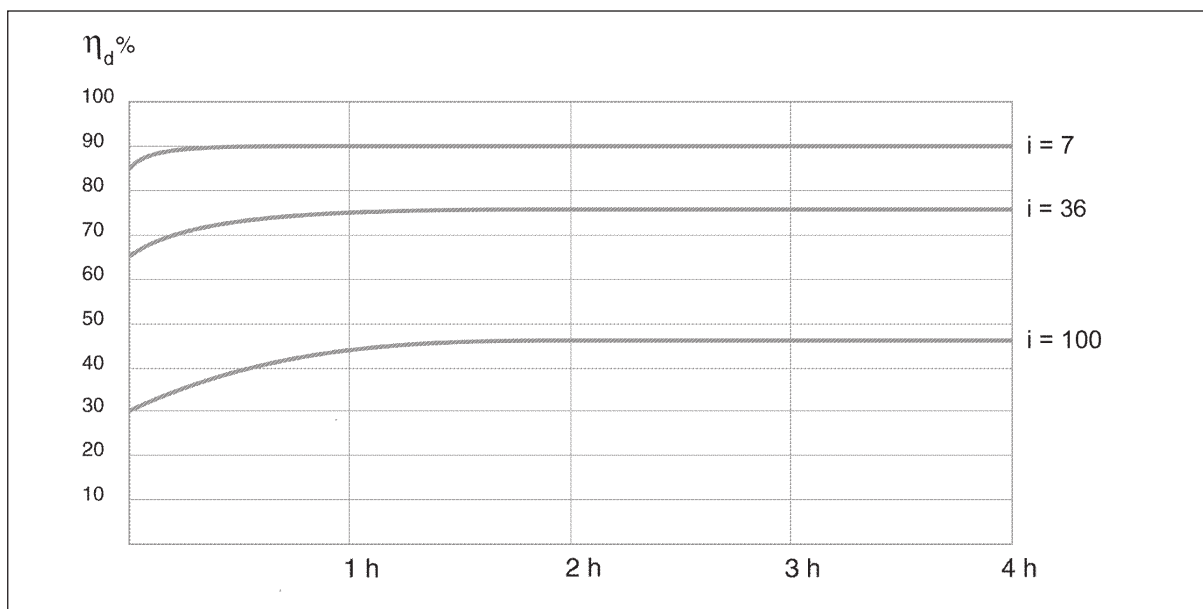

19 IRRÉVERSIBILITÉ

Certaines applications peuvent occasionnellement comporter la transmission du mouvement au moyen de l'arbre lent tandis que d'autres impliquent que la charge soit retenue en position par le motoréducteur, même en l'absence d'alimentation électrique.

Certains groupes à vis sans fin présentent la caractéristique d'être irréversibles et le paramètre qui influence le plus cette performance est leur rendement. Plus particulièrement, le rendement statique η_s est responsable de l'irréversibilité statique (passage à travers une position de repos), tandis que le rendement dynamique η_d est responsable de l'éventuelle irréversibilité dynamique (mouvement continu dans la même direction). L'irréversibilité peut s'exprimer différemment avec des rapports plus longs ($i=64$ et plus) afin d'offrir une irréversibilité supérieure.

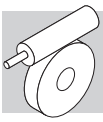

19.1 Irréversibilité statique

Cette condition n'exclut pas le retour lent lorsque le groupe est soumis à des vibrations. La condition théorique pour que se vérifie l'irréversibilité statique est la suivante:

$$\eta_s < 0.4 - 0.5 \quad (15)$$

où η_s est le rendement statique (valeur indiquée dans les tableaux des données techniques des réducteurs). De même pour satisfaire la condition inverse, c'est à dire une réversibilité statique, il faut:

$$\eta_s > 0.5 \quad (16)$$

19.2 Irréversibilité dynamique

C'est la condition la plus difficile à réaliser car elle est influencée directement par la vitesse de rotation, le rendement et les vibrations dues à la charge. Elle est caractérisée par un arrêt instantané du mouvement de rotation quand la vis n'est plus entraînée.

Elle est soumise à la condition théorique suivante:

$$\eta_d < 0.5 \quad (17)$$

où η_d est le rendement dynamique du réducteur dans les conditions réelles de fonctionnement (valeur indiquée dans les tableaux des données techniques des réducteurs). La condition inverse, c'est-à-dire une réversibilité dynamique est réalisée avec:

$$\eta_d > 0.5 \quad (18)$$

Le tableau suivant propose, à titre indicatif, les différents degrés de réversibilité en fonction du type de réducteur et du rapport de réduction (données se référant au couple vis-couronne).

Il va de soi que ces données n'ont de valeur qu'indicative car on peut avoir une irréversibilité plus ou moins accentuée du fait de l'influence des facteurs mentionnés ci-dessus.



Puisque il est pratiquement impossible de réaliser et de garantir une irréversibilité totale, il faudra, là où cela est nécessaire, prévoir un frein extérieur suffisant pour empêcher le démarrage sous l'effet des vibrations.

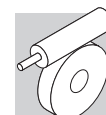

		Degreé de reversibilité												
		VF				W				VF				
Réversibilité statique	Réversibilité dynamique	27	30	44	49	63	75	86	110	130	150	185	210	250
oui	oui	—	—	7	7	7	7	7	7	7	7	7	7	7
oui	oui	7 10	7 10	10 14	10 14	10 12 15	10 15	10 15 20 23	10 15 20 23	10 15 20 23	10 15 20 23	10 15 20 23	10 15 20 23	
incertaine	oui	15 20 30	15 20 30	20 28 35	18 24 28 36	19 24 30 38	20 25 30 40	30 40 46 56	30 40 46 56	30 40 46 56 64	30 40 46 56 64	30 40 50 60	30 40 50 60	
no	mauvaise	40 60	40 60	46 60 70	45 60 70	45 64 80	50 60 80	64 80 100	64 80 100	80 100	80 100	80 100	60 80 100	80 100
no	no	70	70	100	80 100	100	100	—	—	—	—	—	—	—

20 JEUX ANGULAIRES

Le tableau suivant contient les valeurs indicatives du jeu angulaire se référant à l'arbre lent, donc avec arbre rapide bloqué.





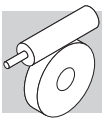

La mesure est effectuée en appliquant un couple de 5 Nm à l'arbre lent.

Jeux angulaires (arbre d'entrée bloqué)		
	$\Delta\gamma$ [']	$\Delta\gamma$ [rad]
VF 30	33' ± 10'	0.00873 ± 0.00291
VF 44	25' ± 7'	0.00728 ± 0.00145
VFR 44	30' ± 10'	0.00873 ± 0.00291
VF 49	22' ± 7'	0.00728 ± 0.00145
VFR 49	30' ± 10'	0.00873 ± 0.00291
W 63	20' ± 4'	0.00582 ± 0.00145
WR 63	25' ± 5'	0.00728 ± 0.00145
W 75	18' ± 4'	0.00582 ± 0.00145
WR 75	22' ± 5'	0.00640 ± 0.00145
W 86	15' ± 4'	0.00436 ± 0.00145
WR 86	20' ± 5'	0.00582 ± 0.00145
W 110	9' ± 2'	0.00436 ± 0.00145
WR 110	18' ± 5'	0.00524 ± 0.00145
VF 130	12' ± 3'	0.00349 ± 0.00087
VFR 130	15' ± 3'	0.00436 ± 0.00087
VF 150	12' ± 3'	0.00349 ± 0.00087
VFR 150	15' ± 3'	0.00436 ± 0.00087
VF 185	10' ± 3'	0.00291 ± 0.00087
VFR 185	13' ± 3'	0.00378 ± 0.00087
VF 210	Nous contacter	
VFR 210		
VF 250		
VFR 250		









21 DONNEES TECHNIQUES MOTOREDUCTEURS







0.04 kW

n ₂ min-1	M ₂ Nm	S	i	Rn ₂ N						IEC 	
19.3	9	1.0	70	600	—	—	—	VF 27_70	P27	BN27A4	109
22.5	8	1.1	60	600	—	—	—	VF 27_60	P27	BN27A4	109
34	6	1.4	40	600	—	—	—	VF 27_40	P27	BN27A4	109
45	5	1.7	30	600	—	—	—	VF 27_30	P27	BN27A4	109
68	4	2.2	20	600	—	—	—	VF 27_20	P27	BN27A4	109
90	3	2.8	15	600	—	—	—	VF 27_15	P27	BN27A4	109
135	2	3.8	10	600	—	—	—	VF 27_10	P27	BN27A4	109
193	2	5.5	7	600	—	—	—	VF 27_7	P27	BN27A4	109

0.06 kW





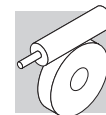

n ₂ min-1	M ₂ Nm	S	i	Rn ₂ N						IEC 	
0.59	203	1.0	2280	5000	—	—	—	VF/W 30/63_2280	P56	BN56A4	127
0.89	155	1.4	1520	5000	—	—	—	VF/W 30/63_1520	P56	BN56A4	127
1.1	122	1.7	1200	5000	—	—	—	VF/W 30/63_1200	P56	BN56A4	127
1.5	115	1.8	900	5000	—	—	—	VF/W 30/63_900	P56	BN56A4	127
1.9	113	1.9	720	5000	—	—	—	VF/W 30/63_720	P56	BN56A4	127
2.5	85	1.1	540	3450	—	—	—	VF/VF 30/49_540	P56	BN56A4	122
2.8	50	1.0	500	5000	—	—	—	VFR 44_500	S44	BN44B4	114
3.2	73	1.3	420	3450	—	—	—	VF/VF 30/49_420	P56	BN56A4	122
4.0	54	1.0	350	5000	—	—	—	VFR 44_350	S44	BN44B4	114
4.3	53	1.8	315	3450	—	—	—	VF/VF 30/49_315	P56	BN56A4	122
4.5	59	1.0	300	2500	—	—	—	VFR 44_300	S44	BN44B4	114
5.8	50	1.2	230	2500	—	—	—	VFR 44_230	S44	BN44B4	114
7.7	42	1.5	175	2500	—	—	—	VFR 44_175	S44	BN44B4	114
9.6	36	1.4	140	2500	—	—	—	VFR 44_140	S44	BN44B4	114
13.4	29	1.8	100	2500	—	—	—	VFR 44_100	S44	BN44B4	114
19.1	22	1.8	70	2500	—	—	—	VFR 44_70	S44	BN44B4	114
19.3	14	1.1	70	1600	—	—	—	VF 30_70	P56	BN56A4	110
22.5	13	1.5	60	1600	—	—	—	VF 30_60	P56	BN56A4	110
34	10	0.9	40	600	—	—	—	VF 27_40	P27	BN27B4	109
34	10	1.9	40	1650	—	—	—	VF 30_40	P56	BN56A4	110
45	8	1.1	30	600	—	—	—	VF 27_30	P27	BN27B4	109
45	8	2.4	30	1340	—	—	—	VF 30_30	P56	BN56A4	110
68	6	1.5	20	600	—	—	—	VF 27_20	P27	BN27B4	109
68	6	2.9	20	1180	—	—	—	VF 30_20	P56	BN56A4	110
90	5	1.9	15	600	—	—	—	VF 27_15	P27	BN27B4	109
90	5	3.7	15	1080	—	—	—	VF 30_15	P56	BN56A4	110
135	4	2.6	10	595	—	—	—	VF 27_10	P27	BN27B4	109
135	3	4.7	10	950	—	—	—	VF 30_10	P56	BN56A4	110
193	2	3.6	7	533	—	—	—	VF 27_7	P27	BN27B4	109
193	2	6.4	7	840	—	—	—	VF 30_7	P56	BN56A4	110

0.09 kW

n ₂ min-1	M ₂ Nm	S	i	Rn ₂ N						IEC 	
0.31	574	1.8	2800	8000	—	—	—	VF/W 49/110_2800	P63	BN63A6	139
0.42	579	1.0	2116	7000	—	—	—	VF/W 44/86_2116	P63	BN63A6	135
0.43	505	2.1	2070	8000	—	—	—	VF/W 49/110_2070	P63	BN63A6	139
0.48	503	1.1	1840	7000	—	—	—	VF/W 44/86_1840	P63	BN63A6	135
0.53	485	2.2	1656	8000	—	—	—	VF/W 49/110_1656	P63	BN63A6	139
0.64	377	1.5	1380	7000	—	—	—	VF/W 44/86_1380	P63	BN63A6	135
0.65	369	2.8	1350	8000	—	—	—	VF/W 49/110_1350	P63	BN63A6	139







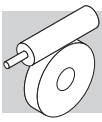

0.09 kW







n ₂ min-1	M ₂ Nm	S	i	R _{n2} N						IEC 	
0.73	363	1.1	1200	5750	—	—	—	VF/W 44/75_1200	P63	BN63A6	131
0.81	316	3.3	1080	8000	—	—	—	VF/W 49/110_1080	P63	BN63A6	139
0.89	232	0.9	1520	5000	—	—	—	VF/W 30/63_1520	P56	BN56B4	127
0.96	323	1.2	920	5750	—	—	—	VF/W 44/75_920	P63	BN63A6	131
0.96	332	1.7	920	7000	—	—	—	VF/W 44/86_920	P63	BN63A6	135
0.98	255	0.9	900	5000	—	—	—	VF/W 30/63_900	P63	BN63A6	127
1.1	183	1.1	1200	5000	—	—	—	VF/W 30/63_1200	P56	BN56B4	127
1.2	225	1.0	720	5000	—	—	—	VF/W 30/63_720	P63	BN63A6	127
1.3	267	1.5	700	5750	—	—	—	VF/W 44/75_700	P63	BN63A6	131
1.3	253	2.2	700	7000	—	—	—	VF/W 44/86_700	P63	BN63A6	135
1.5	172	1.2	900	5000	—	—	—	VF/W 30/63_900	P56	BN56B4	127
1.7	210	1.9	525	5750	—	—	—	VF/W 44/75_525	P63	BN63A6	131
1.7	200	2.8	525	7000	—	—	—	VF/W 44/86_525	P63	BN63A6	135
1.9	170	1.2	720	5000	—	—	—	VF/W 30/63_720	P56	BN56B4	127
2.2	164	2.4	400	5750	—	—	—	VF/W 44/75_400	P63	BN63A6	131
2.2	160	3.4	400	7000	—	—	—	VF/W 44/86_400	P63	BN63A6	135
2.4	145	1.4	570	5000	—	—	—	VF/W 30/63_570	P56	BN56B4	127
2.9	111	1.2	300	5000	—	—	—	WR 63_300	P63	BN63A6	126
2.9	120	1.7	300	6200	—	—	—	WR 75_300	P63	BN63A6	130
2.9	132	2.4	300	7000	—	—	—	WR 86_300	P63	BN63A6	134
3.0	117	1.8	450	5000	—	—	—	VF/W 30/63_450	P56	BN56B4	127
3.2	110	0.9	420	3450	—	—	—	VF/VF 30/49_420	P56	BN56B4	122
3.7	101	1.4	240	5000	—	—	—	WR 63_240	P63	BN63A6	126
3.7	105	2.1	240	6200	—	—	—	WR 75_240	P63	BN63A6	130
3.7	117	2.6	240	7000	—	—	—	WR 86_240	P63	BN63A6	134
4.2	84	0.9	210	3450	—	—	—	VFR 49_210	P63	BN63A6	120
4.3	80	1.2	315	3450	—	—	—	VF/VF 30/49_315	P56	BN56B4	122
4.3	84	2.5	315	5000	—	—	—	VF/W 30/63_315	P56	BN56B4	127
4.6	88	1.7	192	5000	—	—	—	WR 63_192	P63	BN63A6	126
4.9	79	0.9	180	3450	—	—	—	VFR 49_180	P63	BN63A6	120
4.9	90	3.1	180	6200	—	—	—	WR 75_180	P63	BN63A6	130
5.2	94	4.2	168	7000	—	—	—	WR 86_168	P63	BN63A6	134
5.5	62	1.0	245	2500	—	—	—	VF/VF 30/44_245	P56	BN56B4	116
6.5	66	1.2	135	3450	—	—	—	VFR 49_135	P63	BN63A6	120
6.5	71	2.5	135	5000	—	—	—	WR 63_135	P63	BN63A6	126
7.7	63	1.0	175	2900	—	—	—	VFR 44_175	S44	BN44C4	114
7.7	65	3.1	114	5000	—	—	—	WR 63_114	P63	BN63A6	126
8.1	58	1.4	108	3450	—	—	—	VFR 49_108	P63	BN63A6	120
8.8	41	1.3	100	3300	—	—	—	VF 49_100	P63	BN63A6	118
9.6	54	0.9	140	2900	—	—	—	VFR 44_140	S44	BN44C4	114
9.8	55	3.8	90	5000	—	—	—	WR 63_90	P63	BN63A6	126
10.5	48	1.9	84	3450	—	—	—	VFR 49_84	P63	BN63A6	120
11.0	37	1.6	80	3300	—	—	—	VF 49_80	P63	BN63A6	118
12.2	45	1.8	72	3450	—	—	—	VFR 49_72	P63	BN63A6	120
12.2	48	4.0	72	5000	—	—	—	WR 63_72	P63	BN63A6	126
12.6	35	1.1	70	2300	—	—	—	VF 44_70	P63	BN63A6	112
12.6	34	1.8	70	3300	—	—	—	VF 49_70	P63	BN63A6	118
13.4	43	1.2	100	2900	—	—	—	VFR 44_100	S44	BN44C4	114
14.7	32	1.4	60	2300	—	—	—	VF 44_60	P63	BN63A6	112
14.7	34	1.7	60	3300	—	—	—	VF 49_60	P63	BN63A6	118
16.3	36	2.2	54	3450	—	—	—	VFR 49_54	P63	BN63A6	120
19.1	33	1.2	70	2900	—	—	—	VFR 44_70	S44	BN44C4	114
19.1	27	1.8	46	2300	—	—	—	VF 44_46	P63	BN63A6	112
19.6	26	2.7	45	3300	—	—	—	VF 49_45	P63	BN63A6	118
21.0	30	2.8	42	3360	—	—	—	VFR 49_42	P63	BN63A6	120
22.0	22	0.9	40	1560	—	—	—	VF 30_40	P63	BN63A6	110
22.5	19	1.0	60	1600	—	—	—	VF 30_60	P56	BN56B4	110
24.4	22	3.4	36	3300	—	—	—	VF 49_36	P63	BN63A6	118
25.1	22	2.2	35	2300	—	—	—	VF 44_35	P63	BN63A6	112
29.3	18	1.2	30	1440	—	—	—	VF 30_30	P63	BN63A6	110
31	18	2.7	28	2300	—	—	—	VF 44_28	P63	BN63A6	112
34	15	1.2	40	1410	—	—	—	VF 30_40	P56	BN56B4	110
44	14	1.5	20	1230	—	—	—	VF 30_20	P63	BN63A6	110
44	14	3.1	20	2300	—	—	—	VF 44_20	P63	BN63A6	112
45	12	1.6	30	1290	—	—	—	VF 30_30	P56	BN56B4	110
59	11	1.8	15	1170	—	—	—	VF 30_15	P63	BN63A6	110
68	9	1.9	20	1140	—	—	—	VF 30_20	P56	BN56B4	110
69	9	1.0	20	600	—	—	—	VF 27_20	P27	BN27C4	109
88	8	2.3	10	1050	—	—	—	VF 30_10	P63	BN63A6	110
90	7	2.5	15	1050	—	—	—	VF 30_15	P56	BN56B4	110
92	7	1.3	15	600	—	—	—	VF 27_15	P27	BN27C4	109



0.09 kW





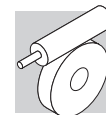

n ₂ min-1	M ₂ Nm	S	i	R _{n2} N						IEC 	
126	6	3.2	7	920	—	—	—	VF 30_7	P63	BN63A6	110
135	5	3.1	10	920	—	—	—	VF 30_10	P56	BN56B4	110
138	5	1.7	10	565	—	—	—	VF 27_10	P27	BN27C4	109
193	4	4.3	7	820	—	—	—	VF 30_7	P56	BN56B4	110
197	4	2.5	7	510	—	—	—	VF 27_7	P27	BN27C4	109

0.12 kW







n ₂ min-1	M ₂ Nm	S	i	R _{n2} N						IEC 	
0.31	775	1.4	2800	8000	—	—	—	VF/W 49/110_2800	P63	BN63B6	139
0.47	588	1.7	2800	8000	—	—	—	VF/W 49/110_2800	P63	BN63A4	139
0.53	654	1.6	1656	8000	—	—	—	VF/W 49/110_1656	P63	BN63B6	139
0.62	518	1.0	2116	7000	—	—	—	VF/W 44/86_2116	P63	BN63A4	135
0.63	507	2.0	2070	8000	—	—	—	VF/W 49/110_2070	P63	BN63A4	139
0.71	483	1.0	1840	7000	—	—	—	VF/W 44/86_1840	P63	BN63A4	135
0.79	435	2.3	1656	8000	—	—	—	VF/W 49/110_1656	P63	BN63A4	139
0.95	386	1.3	1380	7000	—	—	—	VF/W 44/86_1380	P63	BN63A4	135
0.97	354	2.8	1350	8000	—	—	—	VF/W 49/110_1350	P63	BN63A4	139
1.2	293	3.4	1080	8000	—	—	—	VF/W 49/110_1080	P63	BN63A4	139
1.4	322	1.1	920	5750	—	—	—	VF/W 44/75_920	P63	BN63A4	131
1.4	322	1.6	920	7000	—	—	—	VF/W 44/86_920	P63	BN63A4	135
1.5	236	0.9	900	5000	—	—	—	VF/W 30/63_900	P63	BN63A4	127
1.8	233	0.9	720	5000	—	—	—	VF/W 30/63_720	P63	BN63A4	127
1.9	257	1.4	700	5750	—	—	—	VF/W 44/75_700	P63	BN63A4	131
1.9	239	2.1	700	7000	—	—	—	VF/W 44/86_700	P63	BN63A4	135
2.3	199	1.1	570	5000	—	—	—	VF/W 30/63_570	P63	BN63A4	127
2.5	202	1.8	525	5750	—	—	—	VF/W 44/75_525	P63	BN63A4	131
2.5	193	2.6	525	7000	—	—	—	VF/W 44/86_525	P63	BN63A4	135
2.9	150	0.9	300	5000	—	—	—	WR 63_300	P63	BN63B6	126
2.9	162	1.2	300	6200	—	—	—	WR 75_300	P63	BN63B6	130
2.9	178	1.7	300	7000	—	—	—	WR 86_300	P63	BN63B6	134
2.9	161	1.3	450	5000	—	—	—	VF/W 30/63_450	P63	BN63A4	127
3.3	161	2.3	400	5750	—	—	—	VF/W 44/75_400	P63	BN63A4	131
3.3	143	3.5	400	7000	—	—	—	VF/W 44/86_400	P63	BN63A4	135
3.6	136	1.0	240	5000	—	—	—	WR 63_240	P63	BN63B6	126
3.6	142	1.5	240	6200	—	—	—	WR 75_240	P63	BN63B6	130
3.6	142	1.6	240	5000	—	—	—	VF/W 30/63_240	P63	BN63B6	127
3.6	158	2.0	240	7000	—	—	—	WR 86_240	P63	BN63B6	134
4.2	110	0.9	315	3450	—	—	—	VF/VF 30/49_315	P63	BN63A4	122
4.2	116	1.8	315	5000	—	—	—	VF/W 30/63_315	P63	BN63A4	127
4.4	108	1.2	300	5000	—	—	—	WR 63_300	P63	BN63A4	126
4.4	115	1.6	300	6200	—	—	—	WR 75_300	P63	BN63A4	130
4.4	129	2.1	300	7000	—	—	—	WR 86_300	P63	BN63A4	134
4.4	134	2.8	300	5750	—	—	—	VF/W 44/75_300	P63	BN63A4	131
4.8	121	2.3	180	6200	—	—	—	WR 75_180	P63	BN63B6	130
5.2	126	3.1	168	7000	—	—	—	WR 86_168	P63	BN63B6	134
5.2	125	3.0	250	5750	—	—	—	VF/W 44/75_250	P63	BN63A4	131
5.5	94	1.0	240	3450	—	—	—	VF/VF 30/49_240	P63	BN63A4	122
5.5	97	1.4	240	5000	—	—	—	WR 63_240	P63	BN63A4	126
5.5	103	2.1	240	6200	—	—	—	WR 75_240	P63	BN63A4	130
5.5	99	2.1	240	5000	—	—	—	VF/W 30/63_240	P63	BN63A4	127
5.5	111	2.7	240	7000	—	—	—	WR 86_240	P63	BN63A4	134
5.8	109	2.9	150	6200	—	—	—	WR 75_150	P63	BN63B6	130
6.4	89	0.9	135	3300	—	—	—	VFR 49_135	P63	BN63B6	120
6.4	96	1.9	135	5000	—	—	—	WR 63_135	P63	BN63B6	126
6.8	86	1.8	192	5000	—	—	—	WR 63_192	P63	BN63A4	126
7.3	76	0.9	180	3300	—	—	—	VFR 49_180	P63	BN63A4	120
7.3	87	2.7	180	6200	—	—	—	WR 75_180	P63	BN63A4	130
8.7	55	0.9	100	3300	—	—	—	VF 49_100	P63	BN63B6	118
9.7	64	1.4	135	3450	—	—	—	VFR 49_135	P63	BN63A4	120
9.7	68	2.5	135	5000	—	—	—	WR 63_135	P63	BN63A4	126
10.9	50	1.2	80	3300	—	—	—	VF 49_80	P63	BN63B6	118
11.5	61	3.0	114	5000	—	—	—	WR 63_114	P63	BN63A4	126
12.1	55	1.5	108	3450	—	—	—	VFR 49_108	P63	BN63A4	120
13.1	41	1.2	100	3150	—	—	—	VF 49_100	P63	BN63A4	118
14.5	43	1.1	60	2300	—	—	—	VF 44_60	P63	BN63B6	112



0.12 kW





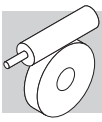

n ₂ min-1	M ₂ Nm	S	i	R _{n2} N						IEC 	
15.3	53	3.6	57	5000	—	—	—	WR 63_57	P63	BN63B6	126
15.6	46	1.9	84	3450	—	—	—	VFR 49_84	P63	BN63A4	120
16.4	36	1.5	80	3150	—	—	—	VF 49_80	P63	BN63A4	118
18.2	42	1.8	72	3430	—	—	—	VFR 49_72	P63	BN63A4	120
18.7	34	0.9	70	3300	—	—	—	VF 44_70	P63	BN63A4	112
18.7	33	1.7	70	3150	—	—	—	VF 49_70	P63	BN63A4	118
21.8	30	1.3	60	2300	—	—	—	VF 44_60	P63	BN63A4	112
21.8	30	1.9	60	3150	—	—	—	VF 49_60	P63	BN63A4	118
24.3	34	2.2	54	3140	—	—	—	VFR 49_54	P63	BN63A4	120
28.5	25	1.5	46	2300	—	—	—	VF 44_46	P63	BN63A4	112
29.0	24	0.9	30	1360	—	—	—	VF 30_30	P63	BN63B6	110
29.1	25	2.6	45	3040	—	—	—	VF 49_45	P63	BN63A4	118
31	27	2.9	42	2920	—	—	—	VFR 49_42	P63	BN63A4	120
33	21	0.9	40	1360	—	—	—	VF 30_40	P63	BN63A4	110
36	21	3.3	36	2830	—	—	—	VF 49_36	P63	BN63A4	118
37	21	1.9	35	2300	—	—	—	VF 44_35	P63	BN63A4	112
44	17	1.2	30	1250	—	—	—	VF 30_30	P63	BN63A4	110
47	17	2.2	28	2300	—	—	—	VF 44_28	P63	BN63A4	112
58	15	1.4	15	1130	—	—	—	VF 30_15	P63	BN63B6	110
62	14	2.7	14	2150	—	—	—	VF 44_14	P63	BN63B6	112
66	13	1.4	20	1110	—	—	—	VF 30_20	P63	BN63A4	110
66	13	2.9	20	2100	—	—	—	VF 44_20	P63	BN63A4	112
87	10	1.8	15	1020	—	—	—	VF 30_15	P63	BN63A4	110
94	10	2.9	14	1870	—	—	—	VF 44_14	P63	BN63A4	112
124	8	2.4	7	900	—	—	—	VF 30_7	P63	BN63B6	110
131	7	2.3	10	900	—	—	—	VF 30_10	P63	BN63A4	110
138	6	1.1	20	560	—	—	—	VF 27_20	P27	BN27C2	109
138	7	2.2	20	840	—	—	—	VF 30_20	P56	BN56B2	110
183	5	1.4	15	520	—	—	—	VF 27_15	P27	BN27C2	109
187	5	3.1	7	810	—	—	—	VF 30_7	P63	BN63A4	110
275	4	2.0	10	460	—	—	—	VF 27_10	P27	BN27C2	109
275	4	3.4	10	740	—	—	—	VF 30_10	P56	BN56B2	110
393	3	2.8	7	410	—	—	—	VF 27_7	P27	BN27C2	109
393	3	4.7	7	660	—	—	—	VF 30_7	P56	BN56B2	110

0.18 kW

n ₂ min-1	M ₂ Nm	S	i	R _{n2} N						IEC 	
0.28	978	1.9	3200	13800	—	—	—	W/VF 63/130_3200	P71	BN71A6	145
0.28	1345	3.3	3200	19500	—	—	—	W/VF 86/185_3200	P71	BN71A6	157
0.31	1406	1.9	2944	16000	—	—	—	W/VF 86/150_2944	P71	BN71A6	151
0.35	1027	1.8	2560	13800	—	—	—	W/VF 63/130_2560	P71	BN71A6	145
0.35	1320	3.3	2560	19500	—	—	—	W/VF 86/185_2560	P71	BN71A6	157
0.47	875	1.1	2800	8000	—	—	—	VF/W 49/110_2800	P63	BN63B4	139
0.49	1265	2.1	1840	16000	—	—	—	W/VF 86/150_1840	P71	BN71A6	151
0.50	894	2.1	1800	13800	—	—	—	W/VF 63/130_1800	P71	BN71A6	145
0.54	949	1.1	1656	8000	—	—	—	VF/W 49/110_1656	P71	BN71A6	139
0.59	871	2.1	1520	13800	—	—	—	W/VF 63/130_1520	P71	BN71A6	145
0.64	755	1.3	2070	8000	—	—	—	VF/W 49/110_2070	P63	BN63B4	139
0.65	1054	2.6	1380	16000	—	—	—	W/VF 86/150_1380	P71	BN71A6	151
0.75	733	2.5	1200	13800	—	—	—	W/VF 63/130_1200	P71	BN71A6	145
0.80	647	1.5	1656	8000	—	—	—	VF/W 49/110_1656	P63	BN63B4	139
0.94	642	2.9	960	13800	—	—	—	W/VF 63/130_960	P71	BN71A6	145
0.98	527	1.9	1350	8000	—	—	—	VF/W 49/110_1350	P63	BN63B4	139
0.98	756	3.6	920	16000	—	—	—	W/VF 86/150_920	P71	BN71A6	151
1.2	537	3.4	760	13800	—	—	—	W/VF 63/130_760	P71	BN71A6	145
1.2	436	2.3	1080	8000	—	—	—	VF/W 49/110_1080	P63	BN63B4	139
1.4	479	1.0	920	7000	—	—	—	VF/W 44/86_920	P63	BN63B4	135
1.7	391	1.4	525	7000	—	—	—	VF/W 44/86_525	P71	BN71A6	135
1.8	375	2.7	720	8000	—	—	—	VF/W 49/110_720	P63	BN63B4	139
1.9	356	1.4	700	7000	—	—	—	VF/W 44/86_700	P63	BN63B4	135
2.3	321	1.2	400	5750	—	—	—	VF/W 44/75_400	P71	BN71A6	131
2.3	313	1.8	400	7000	—	—	—	VF/W 44/86_400	P71	BN71A6	135
2.3	344	3.1	400	8000	—	—	—	VF/W 49/110_400	P71	BN71A6	139
2.4	288	3.5	540	8000	—	—	—	VF/W 49/110_540	P63	BN63B4	139







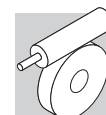

0.18 kW







n ₂ min-1	M ₂ Nm	S	i	R _{n2} N						IEC 		
2.5	301	1.2	525	5750	—	—	—	—	VF/W 44/75_525	P63	BN63B4	131
2.5	287	1.7	525	7000	—	—	—	—	VF/W 44/86_525	P63	BN63B4	135
3.0	258	1.2	300	7000	—	—	—	—	WR 86_300	P71	BN71A6	134
3.0	264	1.5	300	5750	—	—	—	—	VF/W 44/75_300	P71	BN71A6	131
3.0	275	2.1	300	8000	—	—	—	—	WR 110_300	P71	BN71A6	138
3.0	241	2.3	300	7000	—	—	—	—	VF/W 44/86_300	P71	BN71A6	135
3.0	269	3.9	300	8000	—	—	—	—	VF/W 49/110_300	P71	BN71A6	139
3.3	240	1.5	400	5750	—	—	—	—	VF/W 44/75_400	P63	BN63B4	131
3.3	214	2.3	400	7000	—	—	—	—	VF/W 44/86_400	P63	BN63B4	135
3.8	206	1.1	240	6200	—	—	—	—	WR 75_240	P71	BN71A6	130
3.8	229	1.4	240	7000	—	—	—	—	WR 86_240	P71	BN71A6	134
3.8	243	2.4	240	8000	—	—	—	—	WR 110_240	P71	BN71A6	138
3.9	233	2.4	230	7000	—	—	—	—	VF/W 44/86_230	P71	BN71A6	135
4.2	172	1.2	315	5000	—	—	—	—	VF/W 30/63_315	P63	BN63B4	127
4.4	172	1.0	300	6200	—	—	—	—	WR 75_300	P63	BN63B4	130
4.4	191	1.4	300	7000	—	—	—	—	WR 86_300	P63	BN63B4	134
4.4	199	1.9	300	5750	—	—	—	—	VF/W 44/75_300	P63	BN63B4	131
4.4	176	2.8	300	7000	—	—	—	—	VF/W 44/86_300	P63	BN63B4	135
4.7	202	1.9	192	7000	—	—	—	—	WR 86_192	P71	BN71A6	134
5.0	175	1.6	180	6200	—	—	—	—	WR 75_180	P71	BN71A6	130
5.3	186	2.0	250	5750	—	—	—	—	VF/W 44/75_250	P63	BN63B4	131
5.4	183	2.1	168	7000	—	—	—	—	WR 86_168	P71	BN71A6	134
5.5	144	0.9	240	5000	—	—	—	—	WR 63_240	P63	BN63B4	126
5.5	153	1.4	240	6200	—	—	—	—	WR 75_240	P63	BN63B4	130
5.5	147	1.4	240	5000	—	—	—	—	VF/W 30/63_240	P63	BN63B4	127
5.5	166	1.8	240	7000	—	—	—	—	WR 86_240	P63	BN63B4	134
5.7	162	3.1	230	7000	—	—	—	—	VF/W 44/86_230	P63	BN63B4	135
6.0	158	2.0	150	6200	—	—	—	—	WR 75_150	P71	BN71A6	130
6.5	161	2.7	138	7000	—	—	—	—	WR 86_138	P71	BN71A6	134
6.9	128	1.2	192	5000	—	—	—	—	WR 63_192	P63	BN63B4	126
6.9	145	2.3	192	7000	—	—	—	—	WR 86_192	P63	BN63B4	134
7.3	129	1.8	180	6200	—	—	—	—	WR 75_180	P63	BN63B4	130
7.5	138	2.4	120	6200	—	—	—	—	WR 75_120	P71	BN71A6	130
7.9	131	2.7	168	7000	—	—	—	—	WR 86_168	P63	BN63B4	134
7.9	126	1.6	114	5000	—	—	—	—	WR 63_114	P71	BN71A6	126
8.8	113	2.3	150	6200	—	—	—	—	WR 75_150	P63	BN63B4	130
9.0	88	1.4	100	5000	W 63_100	S1	M1SC6	124	W 63_100	P71	BN71A6	125
9.0	96	1.7	100	6200	W 75_100	S1	M1SC6	128	W 75_100	P71	BN71A6	129
9.0	105	2.4	100	7000	W 86_100	S1	M1SC6	132	W 86_100	P71	BN71A6	133
9.8	102	1.7	135	5000	—	—	—	—	WR 63_135	P63	BN63B4	126
10.0	107	1.9	90	5000	—	—	—	—	WR 63_90	P71	BN71A6	126
11.0	98	3.1	120	6200	—	—	—	—	WR 75_120	P63	BN63B4	130
11.3	79	1.6	80	5000	W 63_80	S1	M1SC6	124	W 63_80	P71	BN71A6	125
11.3	83	2.4	80	6200	W 75_80	S1	M1SC6	128	W 75_80	P71	BN71A6	129
11.3	90	3.1	80	7000	W 86_80	S1	M1SC6	132	W 86_80	P71	BN71A6	133
11.6	91	2.0	114	5000	—	—	—	—	WR 63_114	P63	BN63B4	126
12.0	100	3.3	75	6200	—	—	—	—	WR 75_75	P71	BN71A6	130
12.2	82	1.0	108	3450	—	—	—	—	VFR 49_108	P63	BN63B4	120
14.7	75	2.5	90	5000	—	—	—	—	WR 63_90	P63	BN63B4	126
15.0	61	1.1	60	3000	—	—	—	—	VF 49_60	P71	BN71A6	118
15.0	60	1.1	180	3300	—	—	—	—	VFR 49_180	P63	BN63A2	120
15.7	68	1.3	84	3420	—	—	—	—	VFR 49_84	P63	BN63B4	120
16.5	54	1.0	80	3150	—	—	—	—	VF 49_80	P63	BN63B4	118
18.3	63	1.2	72	3270	—	—	—	—	VFR 49_72	P63	BN63B4	120
18.3	66	2.8	72	5000	—	—	—	—	WR 63_72	P63	BN63B4	126
18.9	49	1.1	70	3150	—	—	—	—	VF 49_70	P63	BN63B4	118
20.0	50	1.4	135	3280	—	—	—	—	VFR 49_135	P63	BN63A2	120
20.0	54	2.9	45	5000	W63_45	S1	M1SC6	124	W 63_45	P71	BN71A6	125
22.0	45	0.9	60	2300	—	—	—	112	VF 44_60	P63	BN63B4	112
22.0	45	1.3	60	3150	—	—	—	—	VF 49_60	P63	BN63B4	118
23.2	54	3.3	57	4910	—	—	—	—	WR 63_57	P63	BN63B4	126
24.4	50	1.5	54	3010	—	—	—	—	VFR 49_54	P63	BN63B4	120
28.7	38	1.0	46	2500	—	—	—	—	VF 44_46	P63	BN63B4	112
29.3	37	1.8	45	2300	—	—	—	—	VF 49_45	P63	BN63B4	118
31	40	1.9	42	2810	—	—	—	—	VFR 49_42	P63	BN63B4	120
32	36	1.4	28	2290	—	—	—	—	VF 44_28	P71	BN71A6	112
37	31	2.2	36	2760	—	—	—	—	VF 49_36	P63	BN63B4	118
38	31	1.3	35	2430	—	—	—	—	VF 44_35	P63	BN63B4	112
47	26	1.5	28	2270	—	—	—	—	VF 44_28	P63	BN63B4	112



0.18 kW





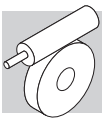

n ₂ min-1	M ₂ Nm	S	i	Rn ₂ N						IEC 	
47	26	2.9	28	2560	—	—	—	VF 49_28	P63	BN63B4	118
55	23	2.7	24	2430	—	—	—	VF 49_24	P63	BN63B4	118
66	19	0.9	20	1040	—	—	—	VF 30_20	P63	BN63B4	110
66	20	1.9	20	2040	—	—	—	VF 44_20	P63	BN63B4	112
73	18	3.2	18	2230	—	—	—	VF 49_18	P63	BN63B4	118
77	16	1.8	35	1970	—	—	—	VF 44_35	P63	BN63A2	112
88	15	1.2	15	960	—	—	—	VF 30_15	P63	BN63B4	110
94	15	2.0	14	1830	—	—	—	VF 44_14	P63	BN63B4	112
132	11	1.5	10	860	—	—	—	VF 30_10	P63	BN63B4	110
132	11	2.7	10	1640	—	—	—	VF 44_10	P63	BN63B4	112
189	8	2.1	7	770	—	—	—	VF 30_7	P63	BN63B4	110
193	7	2.9	14	1470	—	—	—	VF 44_14	P63	BN63A2	112
270	5	2.2	10	710	—	—	—	VF 30_10	P63	BN63A2	110
386	4	3.1	7	640	—	—	—	VF 30_7	P63	BN63A2	110

0.25 kW

n ₂ min-1	M ₂ Nm	S	i	Rn ₂ N						IEC 	
0.28	1358	1.4	3200	13800	—	—	—	W/VF 63/130_3200	P71	BN71B6	145
0.28	1868	2.4	3200	19500	—	—	—	W/VF 86/185_3200	P71	BN71B6	157
0.31	1952	1.4	2944	16000	—	—	—	W/VF 86/150_2944	P71	BN71B6	151
0.43	945	1.9	3200	13800	—	—	—	W/VF 63/130_3200	P71	BN71A4	145
0.43	1334	3.1	3200	19500	—	—	—	W/VF 86/185_3200	P71	BN71A4	157
0.47	1380	1.9	2944	16000	—	—	—	W/VF 86/150_2944	P71	BN71A4	151
0.49	1562	2.8	1840	19500	—	—	—	W/VF 86/185_1840	P71	BN71B6	157
0.54	1022	1.8	2560	13800	—	—	—	W/VF 63/130_2560	P71	BN71A4	145
0.54	1289	3.3	2560	19500	—	—	—	W/VF 86/185_2560	P71	BN71A4	157
0.65	1464	1.8	1380	16000	—	—	—	W/VF 86/150_1380	P71	BN71B6	151
0.66	1006	1.0	2070	8000	—	—	—	VF/W 49/110_2070	P71	BN71A4	139
0.75	1214	2.1	1840	16000	—	—	—	W/VF 86/150_1840	P71	BN71A4	151
0.75	1019	1.8	1200	13800	—	—	—	W/VF 63/130_1200	P71	BN71B6	145
0.76	875	2.1	1800	13800	—	—	—	W/VF 63/130_1800	P71	BN71A4	145
0.83	863	1.2	1656	8000	—	—	—	VF/W 49/110_1656	P71	BN71A4	139
0.90	845	2.1	1520	13800	—	—	—	W/VF 63/130_1520	P71	BN71A4	145
0.98	1049	2.6	920	16000	—	—	—	W/VF 86/150_920	P71	BN71B6	151
1.0	1006	2.6	1380	16000	—	—	—	W/VF 86/150_1380	P71	BN71A4	151
1.0	703	1.4	1350	8000	—	—	—	VF/W 49/110_1350	P71	BN71A4	139
1.1	708	2.5	1200	13800	—	—	—	W/VF 63/130_1200	P71	BN71A4	145
1.2	746	2.5	760	13800	—	—	—	W/VF 63/130_760	P71	BN71B6	145
1.3	581	1.7	1080	8000	—	—	—	VF/W 49/110_1080	P71	BN71A4	139
1.3	860	3.1	690	16000	—	—	—	W/VF 86/150_690	P71	BN71B6	151
1.4	617	2.9	960	13800	—	—	—	W/VF 63/130_960	P71	BN71A4	145
1.7	544	1.9	540	8000	—	—	—	VF/W 49/110_540	P71	BN71B6	139
1.7	543	1.0	525	7000	—	—	—	VF/W 44/86_525	P71	BN71B6	135
1.8	515	3.5	760	13800	—	—	—	W/VF 63/130_760	P71	BN71A4	145
1.9	500	2.0	720	8000	—	—	—	VF/W 49/110_720	P71	BN71A4	139
2.0	474	1.1	700	7000	—	—	—	VF/W 44/86_700	P71	BN71A4	135
2.5	384	2.6	540	8000	—	—	—	VF/W 49/110_540	P71	BN71A4	139
2.6	383	1.3	525	7000	—	—	—	VF/W 44/86_525	P71	BN71A4	135
3.0	366	1.1	300	5750	—	—	—	VF/W 44/75_300	P71	BN71B6	131
3.0	382	1.5	300	8000	—	—	—	WR 110_300	P71	BN71B6	138
3.0	374	2.8	300	8000	—	—	—	VF/W 49/110_300	P71	BN71B6	139
3.4	319	1.2	400	5750	—	—	—	VF/W 44/75_400	P71	BN71A4	131
3.4	285	1.8	400	7000	—	—	—	VF/W 44/86_400	P71	BN71A4	135
3.4	313	3.2	400	8000	—	—	—	VF/W 49/110_400	P71	BN71A4	139
3.8	318	1.0	240	7000	—	—	—	WR 86_240	P71	BN71B6	134
3.8	337	1.7	240	8000	—	—	—	WR 110_240	P71	BN71B6	138
3.9	323	1.7	230	7000	—	—	—	VF/W 44/86_230	P71	BN71B6	135
3.9	311	3.4	230	8000	—	—	—	VF/W 49/110_230	P71	BN71B6	139
4.6	255	1.1	300	7000	—	—	—	WR 86_300	P71	BN71A4	134
4.6	266	1.4	300	5750	—	—	—	VF/W 44/75_300	P71	BN71A4	131
4.6	266	2.1	300	8000	—	—	—	WR 110_300	P71	BN71A4	138
4.6	234	2.1	300	7000	—	—	—	VF/W 44/86_300	P71	BN71A4	135
4.7	280	1.4	192	7000	—	—	—	WR 86_192	P71	BN71B6	134







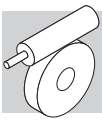

0.25 kW

n ₂ min-1	M ₂ Nm	S	i	R _{n2} N						IEC 		
5.5	247	1.5	250	5750	—	—	—	—	VF/W 44/75_250	P71	BN71A4	131
5.7	204	1.1	240	6200	—	—	—	—	WR 75_240	P71	BN71A4	130
5.7	221	1.4	240	7000	—	—	—	—	WR 86_240	P71	BN71A4	134
5.7	233	2.4	240	8000	—	—	—	—	WR 110_240	P71	BN71A4	138
6.0	216	2.3	230	7000	—	—	—	—	VF/W 44/86_230	P71	BN71A4	135
6.0	219	1.4	150	6200	—	—	—	—	WR 75_150	P71	BN71B6	130
6.7	193	0.9	135	5000	—	—	—	—	WR 63_135	P71	BN71B6	126
7.2	193	1.7	192	7000	—	—	—	—	WR 86_192	P71	BN71A4	134
7.2	200	3.1	192	8000	—	—	—	—	WR 110_192	P71	BN71A4	138
7.6	172	1.4	180	6200	—	—	—	—	WR 75_180	P71	BN71A4	130
7.9	175	1.1	114	5000	—	—	—	—	WR 63_114	P71	BN71B6	126
8.2	175	2.0	168	7000	—	—	—	—	WR 86_168	P71	BN71A4	134
9.0	122	1.0	100	5000	W 63_100	S1	M1SD6	124	—	—	—	—
9.0	133	1.2	100	6200	W 75_100	S1	M1SD6	128	W 75_100	P71	BN71B6	129
9.0	146	1.7	100	7000	W 86_100	S1	M1SD6	132	W 86_100	P71	BN71B6	133
9.2	151	1.7	150	6200	—	—	—	—	WR 75_150	P71	BN71A4	130
10.0	151	2.7	138	7000	—	—	—	—	WR 86_138	P71	BN71A4	134
10.0	160	2.3	90	6200	—	—	—	—	WR 75_90	P71	BN71B6	130
10.2	136	1.3	135	5000	—	—	—	—	WR 63_135	P71	BN71A4	126
11.3	110	1.1	80	5000	W 63_80	S1	M1SD6	124	—	—	—	—
11.3	115	1.7	80	6200	W 75_80	S1	M1SD6	128	W 75_80	P71	BN71B6	129
11.3	125	2.2	80	7000	W 86_80	S1	M1SD6	132	W 86_80	P71	BN71B6	133
11.5	131	2.3	120	6200	—	—	—	—	WR 75_120	P71	BN71A4	130
11.5	138	2.8	120	7000	—	—	—	—	WR 86_120	P71	BN71A4	134
12.1	121	1.5	114	5000	—	—	—	—	WR 63_114	P71	BN71A4	126
13.8	89	1.3	100	5000	—	—	—	—	W 63_100	P71	BN71A4	125
13.8	96	1.6	100	6200	—	—	—	—	W 75_100	P71	BN71A4	129
13.8	102	2.2	100	7000	—	—	—	—	W 86_100	P71	BN71A4	133
15.3	100	1.9	90	5000	—	—	—	—	WR 63_90	P71	BN71A4	126
15.3	108	3.0	90	6200	—	—	—	—	WR 75_90	P71	BN71A4	130
17.2	78	1.5	80	5000	—	—	—	—	W 63_80	P71	BN71A4	125
17.2	82	2.2	80	6200	—	—	—	—	W 75_80	P71	BN71A4	129
17.2	89	2.9	80	7000	—	—	—	—	W 86_80	P71	BN71A4	133
18.3	95	3.1	75	6200	—	—	—	—	WR 75_75	P71	BN71A4	130
19.1	88	2.1	72	5000	—	—	—	—	WR 63_72	P71	BN71A4	126
20.0	70	1.0	45	3150	—	—	—	—	—	—	—	—
21.5	68	1.8	64	5000	—	—	—	—	W 63_64	P71	BN71A4	125
22.0	63	0.9	60	3150	—	—	—	—	—	—	—	—
22.9	68	3.0	60	6200	—	—	—	—	W 75_60	P71	BN71A4	129
24.1	72	2.5	57	4780	—	—	—	—	WR 63_57	P71	BN71A4	126
29.3	51	1.3	45	2850	—	—	—	—	—	—	—	—
31	52	2.8	45	4550	—	—	—	—	W 63_45	P71	BN71A4	125
31	59	3.0	45	4460	—	—	—	—	WR 63_45	P71	BN71A4	126
32	50	1.0	28	2300	—	—	—	—	VF 44_28	P71	BN71B6	112
36	46	3.4	38	4320	—	—	—	—	W 63_38	P71	BN71A4	125
37	44	1.6	36	2670	—	—	—	—	VF 49_36	P71	BN71A4	118
38	43	0.9	35	2300	—	—	—	—	VF 44_35	P71	BN71A4	112
38	49	3.3	36	4160	—	—	—	—	WR 63_36	P71	BN71A4	126
45	39	1.1	20	2190	—	—	—	—	VF 44_20	P71	BN71B6	112
47	36	1.1	28	2190	—	—	—	—	VF 44_28	P71	BN71A4	112
47	36	2.1	28	2480	—	—	—	—	VF 49_28	P71	BN71A4	118
55	33	1.9	24	2360	—	—	—	—	VF 49_24	P71	BN71A4	118
64	29	1.3	14	1980	—	—	—	—	VF 44_14	P71	BN71B6	112
64	29	2.5	14	2260	—	—	—	—	VF 49_14	P71	BN71B6	118
66	28	1.4	20	1970	—	—	—	—	VF 44_20	P71	BN71A4	112
73	25	2.3	18	2170	—	—	—	—	VF 49_18	P71	BN71A4	118
77	23	1.3	35	1930	—	—	—	—	VF 44_35	P63	BN63B2	112
90	22	1.8	10	1780	—	—	—	—	VF 44_10	P71	BN71B6	112
90	22	2.9	10	2040	—	—	—	—	VF 49_10	P71	BN71B6	118
94	21	1.4	14	1770	—	—	—	—	VF 44_14	P71	BN71A4	112
94	21	3.2	14	2010	—	—	—	—	VF 49_14	P71	BN71A4	118
113	17	2.8	24	1930	—	—	—	—	VF 49_24	P63	BN63B2	118
129	16	2.5	7	1590	—	—	—	—	VF 44_7	P71	BN71B6	112
132	15	1.9	10	1590	—	—	—	—	VF 44_10	P71	BN71A4	112
135	14	1.0	20	840	—	—	—	—	VF 30_20	P63	BN63B2	110
180	11	1.3	15	780	—	—	—	—	VF 30_15	P63	BN63B2	110
189	11	2.7	7	1420	—	—	—	—	VF 44_7	P71	BN71A4	112
270	8	1.6	10	690	—	—	—	—	VF 30_10	P63	BN63B2	110







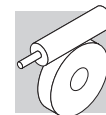

0.37 kW







n ₂ min-1	M ₂ Nm	S	i	R _{n2} N						IEC 		
7.1	287	1.1	192	7000	—	—	—	—	WR 86_192	P71	BN71B4	134
7.1	297	2.1	192	8000	—	—	—	—	WR 110_192	P71	BN71B4	138
7.6	294	1.5	120	7000	—	—	—	—	WR 86_120	P80	BN80A6	134
7.6	303	2.9	120	8000	—	—	—	—	WR 110_120	P80	BN80A6	138
7.6	255	0.9	180	6200	—	—	—	—	WR 75_180	P71	BN71B4	130
8.2	260	1.4	168	7000	—	—	—	—	WR 86_168	P71	BN71B4	134
8.2	273	2.6	168	8000	—	—	—	—	WR 110_168	P71	BN71B4	138
9.1	214	1.2	100	7000	W 86_100	S1	M1LA6	132	W 86_100	P80	BN80A6	133
9.1	224	1.2	150	6200	—	—	—	—	WR 75_150	P71	BN71B4	130
9.9	224	1.8	138	7000	—	—	—	—	WR 86_138	P71	BN71B4	134
9.9	235	3.0	138	8000	—	—	—	—	WR 110_138	P71	BN71B4	138
10.1	234	1.6	90	6200	—	—	—	—	WR 75_90	P80	BN80A6	130
11.4	168	1.2	80	6200	W 75_80	S1	M1LA6	128	W 75_80	P80	BN80A6	129
11.4	183	1.5	80	7000	W 86_80	S1	M1LA6	132	W 86_80	P80	BN80A6	133
11.4	195	1.6	120	6200	—	—	—	—	WR 75_120	P71	BN71B4	130
11.4	204	1.9	120	7000	—	—	—	—	WR 86_120	P71	BN71B4	134
12.0	179	1.0	114	5000	—	—	—	—	WR 63_114	P71	BN71B4	126
12.1	204	1.6	75	6200	—	—	—	—	WR 75_75	P80	BN80A6	130
13.2	196	2.0	69	7000	—	—	—	—	WR 86_69	P80	BN80A6	134
13.7	142	1.1	100	6200	W 75_100	S1	M1SD4	128	W 75_100	P71	BN71B4	129
13.7	152	1.5	100	7000	W 86_100	S1	M1SD4	132	W 86_100	P71	BN71B4	133
14.2	139	1.0	64	5000	W 63_64	S1	M1LA6	124	W 63_64	P80	BN80A6	125
15.2	140	1.5	60	6200	W 75_60	S1	M1LA6	128	W 75_60	P80	BN80A6	129
15.2	149	1.3	90	5000	—	—	—	—	WR 63_90	P71	BN71B4	126
15.2	160	2.0	90	6200	—	—	—	—	WR 75_90	P71	BN71B4	130
15.2	156	2.8	90	7000	—	—	—	—	WR 86_90	P71	BN71B4	134
16.3	144	2.3	56	7000	W 86_56	S1	M1LA6	132	W 86_56	P80	BN80A6	133
17.1	116	1.0	80	5000	W 63_80	S1	M1SD4	124	W 63_80	P71	BN71B4	125
17.1	122	1.5	80	6200	W 75_80	S1	M1SD4	128	W 75_80	P71	BN71B4	129
17.1	132	1.9	80	7000	W 86_80	S1	M1SD4	132	W 86_80	P71	BN71B4	133
18.3	141	2.1	75	6200	—	—	—	—	WR 75_75	P71	BN71B4	130
19.0	130	1.4	72	4830	—	—	—	—	WR 63_72	P71	BN71B4	126
19.9	133	2.8	69	7000	—	—	—	—	WR 86_69	P71	BN71B4	134
20.2	136	2.6	45	6200	—	—	—	—	WR 75_45	P80	BN80A6	130
21.4	101	1.2	64	4870	W 63_64	S1	M1SD4	124	W 63_64	P71	BN71B4	125
21.4	112	2.5	64	7000	W 86_64	S1	M1SD4	132	W 86_64	P71	BN71B4	133
22.8	101	2.0	60	6200	W 75_60	S1	M1SD4	128	W 75_60	P71	BN71B4	129
22.8	119	2.5	60	6200	—	—	—	—	WR 75_60	P71	BN71B4	130
22.8	119	3.2	60	7000	—	—	—	—	WR 86_60	P71	BN71B4	134
24.0	107	1.7	57	4540	—	—	—	—	WR 63_57	P71	BN71B4	126
24.5	101	3.0	56	7000	W 86_56	S1	M1SD4	132	W 86_56	P71	BN71B4	133
27.4	88	2.5	50	6200	W 75_50	S1	M1SD4	128	W 75_50	P71	BN71B4	129
30	73	0.9	45	2680	—	—	—	—	VF 49_45	P71	BN71B4	118
30	78	1.9	45	4400	W 63_45	S1	M1SD4	124	W 63_45	P71	BN71B4	125
30	88	2.0	45	4250	—	—	—	—	WR 63_45	P71	BN71B4	126
30	93	3.2	45	5885	—	—	—	—	WR 75_45	P71	BN71B4	130
34	74	3.4	40	5820	W 75_40	S1	M1SD4	128	W 75_40	P71	BN71B4	129
36	69	2.3	38	4180	W 63_38	S1	M1SD4	124	W 63_38	P71	BN71B4	125
38	62	1.1	36	2530	—	—	—	—	VF 49_36	P71	BN71B4	118
38	73	2.2	36	3980	—	—	—	—	WR 63_36	P71	BN71B4	126
46	57	2.8	30	3900	W 63_30	S1	M1SD4	124	W 63_30	P71	BN71B4	125
49	51	1.4	28	2360	—	—	—	—	VF 49_28	P71	BN71B4	118
57	46	1.4	24	2250	—	—	—	—	VF 49_24	P71	BN71B4	118
57	48	3.2	24	3650	W 63_24	S1	M1SD4	124	W 63_24	P71	BN71B4	125
65	42	1.7	14	1940	—	—	—	—	VF 49_14	P80	BN80A6	118
69	40	1.0	20	1870	—	—	—	—	VF 44_20	P71	BN71B4	112
72	40	3.8	19	3400	W 63_19	S1	M1SD4	124	W 63_19	P71	BN71B4	125
76	36	1.6	18	2080	—	—	—	—	VF 49_18	P71	BN71B4	118
79	33	0.9	35	1860	—	—	—	—	VF 44_35	P71	BN71A2	112
91	32	2.0	10	1930	—	—	—	—	VF 49_10	P80	BN80A6	118
98	29	1.0	14	1690	—	—	—	—	VF 44_14	P71	BN71B4	112
98	29	2.2	14	1940	—	—	—	—	VF 49_14	P71	BN71B4	118
117	24	2.0	24	1880	—	—	—	—	VF 49_24	P71	BN71A2	118
137	22	1.3	10	1520	—	—	—	—	VF 44_10	P71	BN71B4	112
137	22	2.7	10	1750	—	—	—	—	VF 49_10	P71	BN71B4	118



0.37 kW





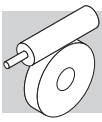

n ₂ min-1	M ₂ Nm	S	i	Rn ₂ N						IEC 	
138	21	1.4	20	1570	—	—	—	VF 44_20	P71	BN71A2	112
153	19	2.3	18	1720	—	—	—	VF 49_18	P71	BN71A2	118
196	16	1.9	7	1360	—	—	—	VF 44_7	P71	BN71B4	112
196	16	3.5	7	1570	—	—	—	VF 49_7	P71	BN71B4	118
275	11	2.0	10	1260	—	—	—	VF 44_10	P71	BN71A2	112
393	8	2.8	7	1120	—	—	—	VF 44_7	P71	BN71A2	112

0.55 kW

n ₂ min-1	M ₂ Nm	S	i	Rn ₂ N						IEC 	
0.29	4019	1.1	3200	19500	—	—	—	W/VF 86/185_3200	P80	BN80B6	157
0.36	3946	1.1	2560	19500	—	—	—	W/VF 86/185_2560	P80	BN80B6	157
0.43	2902	1.4	3200	19500	—	—	—	W/VF 86/185_3200	P80	BN80A4	157
0.47	3004	0.9	2944	16000	—	—	—	W/VF 86/150_2944	P80	BN80A4	151
0.50	3362	1.3	1840	19500	—	—	—	W/VF 86/185_1840	P80	BN80B6	157
0.54	2805	1.5	2560	19500	—	—	—	W/VF 86/185_2560	P80	BN80A4	157
0.76	2642	1.0	1840	16000	—	—	—	W/VF 86/150_1840	P80	BN80A4	151
0.76	2364	1.8	1840	19500	—	—	—	W/VF 86/185_1840	P80	BN80A4	157
0.77	1905	0.9	1800	13800	—	—	—	W/VF 63/130_1800	P80	BN80A4	145
0.87	2116	2.0	1600	19500	—	—	—	W/VF 86/185_1600	P80	BN80A4	157
0.91	1838	1.0	1520	13800	—	—	—	W/VF 63/130_1520	P80	BN80A4	145
1.0	1996	2.2	920	19500	—	—	—	W/VF 86/185_920	P80	BN80B6	157
1.0	2190	1.2	1380	16000	—	—	—	W/VF 86/150_1380	P80	BN80A4	151
1.2	1542	1.2	1200	13800	—	—	—	W/VF 63/130_1200	P80	BN80A4	145
1.2	1542	2.7	1200	19500	—	—	—	W/VF 86/185_1200	P80	BN80A4	157
1.3	1852	1.5	690	16000	—	—	—	W/VF 86/150_690	P80	BN80B6	151
1.4	1342	1.3	960	13800	—	—	—	W/VF 63/130_960	P80	BN80A4	145
1.5	1564	1.7	920	16000	—	—	—	W/VF 86/150_920	P80	BN80A4	151
1.5	1460	2.9	920	19500	—	—	—	W/VF 86/185_920	P80	BN80A4	157
1.5	1473	3.0	600	19500	—	—	—	W/VF 86/185_600	P80	BN80B6	157
1.7	1300	3.2	800	19500	—	—	—	W/VF 86/185_800	P80	BN80A4	157
1.7	1570	1.7	529	16000	—	—	—	W/VF 86/150_529	P80	BN80B6	151
1.8	1120	1.6	760	13800	—	—	—	W/VF 63/130_760	P80	BN80A4	145
2.0	1304	2.0	690	16000	—	—	—	W/VF 86/150_690	P80	BN80A4	151
2.3	1028	1.0	400	8000	—	—	—	VF/W 49/110_400	P80	BN80B6	139
2.3	907	2.0	600	13800	—	—	—	W/VF 63/130_600	P80	BN80A4	145
2.6	837	1.2	540	8000	—	—	—	VF/W 49/110_540	P80	BN80A4	139
2.6	1099	2.4	529	16000	—	—	—	W/VF 86/150_529	P80	BN80A4	151
3.0	956	2.7	460	16000	—	—	—	W/VF 86/150_460	P80	BN80A4	151
3.1	839	1.2	300	13800	—	—	—	VFR 130_300	P80	BN80B6	142
3.1	805	1.3	300	8000	—	—	—	VF/W 49/110_300	P80	BN80B6	139
3.5	680	1.5	400	8000	—	—	—	VF/W 49/110_400	P80	BN80A4	139
3.5	665	2.7	400	13800	—	—	—	W/VF 63/130_400	P80	BN80A4	145
3.8	740	1.6	240	13800	—	—	—	VFR 130_240	P80	BN80B6	142
4.0	670	1.6	230	8000	—	—	—	VF/W 49/110_230	P80	BN80B6	139
4.0	756	3.4	345	16000	—	—	—	W/VF 86/150_345	P80	BN80A4	151
4.6	578	0.9	300	8000	—	—	—	WR 110_300	P80	BN80A4	138
4.6	601	1.5	300	13800	—	—	—	VFR 130_300	P80	BN80A4	142
4.6	544	1.8	300	8000	—	—	—	VF/W 49/110_300	P80	BN80A4	139
4.8	625	1.1	192	8000	—	—	—	WR 110_192	P80	BN80B6	138
5.0	529	3.4	280	13800	—	—	—	W/VF 63/130_280	P80	BN80A4	145
5.8	508	1.1	240	8000	—	—	—	WR 110_240	P80	BN80A4	138
5.8	517	2.2	240	13800	—	—	—	VFR 130_240	P80	BN80A4	142
6.0	452	2.2	230	8000	—	—	—	VF/W 49/110_230	P80	BN80A4	139
6.7	504	3.0	138	13800	—	—	—	VFR 130_138	P80	BN80B6	142
7.2	435	1.4	192	8000	—	—	—	WR 110_192	P80	BN80A4	138
7.2	443	2.7	192	13800	—	—	—	VFR 130_192	P80	BN80A4	142
7.7	432	1.0	120	7000	—	—	—	WR 86_120	P80	BN80B6	134
8.3	381	0.9	168	7000	—	—	—	WR 86_168	P80	BN80A4	134
8.3	400	1.8	168	8000	—	—	—	WR 110_168	P80	BN80A4	138
8.3	406	3.0	168	13800	—	—	—	VFR 130_168	P80	BN80A4	142







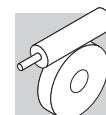

0.55 kW

n ₂ min-1	M ₂ Nm	S	i	R _{n2} N						IEC 		
9.2	325	1.5	100	8000	W 110_100	S2	M2SA6	136	W 110_100	P80	BN80B6	137
10.1	329	1.2	138	7000	—	—	—	—	WR 86_138	P80	BN80A4	134
10.1	344	2.1	138	8000	—	—	—	—	WR 110_138	P80	BN80A4	138
10.2	344	1.1	90	6200	—	—	—	—	WR 75_90	P80	BN80B6	130
11.5	269	1.0	80	7000	W 86_80	S2	M2SA6	132	W 86_80	P80	BN80B6	133
11.6	286	1.1	120	6200	—	—	—	—	WR 75_120	P80	BN80A4	130
11.6	299	1.3	120	7000	—	—	—	—	WR 86_120	P80	BN80A4	134
11.6	308	2.6	120	8000	—	—	—	—	WR 110_120	P80	BN80A4	138
12.3	300	1.1	75	6200	—	—	—	—	WR 75_75	P80	BN80B6	130
13.3	288	1.4	69	7000	—	—	—	—	WR 86_69	P80	BN80B6	134
13.3	295	2.5	69	8000	—	—	—	—	WR 110_69	P80	BN80B6	138
13.8	225	1.0	100	7000	W 86_100	S1	M1LA4	132	W 86_100	P80	BN80A4	133
15.4	235	1.4	90	6200	—	—	—	—	WR 75_90	P80	BN80A4	130
15.4	228	1.9	90	7000	—	—	—	—	WR 86_90	P80	BN80A4	134
15.4	238	3.5	90	8000	—	—	—	—	WR 110_90	P80	BN80A4	138
16.4	211	1.5	56	7000	W 86_56	S2	M2SA6	132	W 86_56	P80	BN80B6	133
17.3	180	1.0	80	6200	W 75_80	S1	M1LA4	128	W 75_80	P80	BN80A4	129
17.3	195	1.3	80	7000	W 86_80	S1	M1LA4	132	W 86_80	P80	BN80A4	133
18.5	207	1.4	75	6200	—	—	—	—	WR 75_75	P80	BN80A4	130
20.1	196	1.9	69	7000	—	—	—	—	WR 86_69	P80	BN80A4	134
20.1	201	3.2	69	8000	—	—	—	—	WR 110_69	P80	BN80A4	138
20.4	162	1.0	45	4540	W 63_45	S2	M2SA6	124	W 63_45	P80	BN80B6	125
21.6	166	1.7	64	7000	W 86_64	S1	M1LA4	132	W 86_64	P80	BN80A4	133
23.0	148	1.3	60	6200	W 75_60	S1	M1LA4	128	W 75_60	P80	BN80A4	129
23.0	162	2.2	40	7000	W 86_40	S2	M2SA6	132	W 86_40	P80	BN80B6	133
23.2	175	1.7	60	6040	—	—	—	—	WR 75_60	P80	BN80A4	130
23.2	175	2.2	60	7000	—	—	—	—	WR 86_60	P80	BN80A4	134
24.2	143	1.2	38	4340	W 63_38	S2	M2SA6	124	W 63_38	P80	BN80B6	125
24.6	149	2.0	56	7000	W 86_56	S1	M1LA4	132	W 86_56	P80	BN80A4	133
27.6	129	1.7	50	5960	W 75_50	S1	M1LA4	128	W 75_50	P80	BN80A4	129
30	128	2.7	46	7000	W 86_46	S1	M1LA4	132	W 86_46	P80	BN80A4	133
31	115	1.3	45	4140	W 63_45	S1	M1LA4	124	W 63_45	P80	BN80A4	125
31	136	2.2	45	5580	—	—	—	—	WR 75_45	P80	BN80A4	130
31	133	2.9	45	7000	—	—	—	—	WR 86_45	P80	BN80A4	134
35	110	2.3	40	5610	W 75_40	S1	M1LA4	128	W 75_40	P80	BN80A4	129
35	114	2.9	40	7000	W 86_40	S1	M1LA4	132	W 86_40	P80	BN80A4	133
36	101	1.5	38	3950	W 63_38	S1	M1LA4	124	W 63_38	P80	BN80A4	125
40	105	3.3	23	7000	W 86_23	S2	M2SA6	132	W 86_23	P80	BN80B6	133
46	84	1.9	30	3700	W 63_30	S1	M1LA4	124	W 63_30	P80	BN80A4	125
46	88	3.1	30	5150	W 75_30	S1	M1LA4	128	W 75_30	P80	BN80A4	129
46	95	2.9	30	4950	—	—	—	—	WR 75_30	P80	BN80A4	130
49	76	1.0	28	2170	—	—	—	—	VF 49_28	P80	BN80A4	118
55	76	3.3	25	4880	W 75_25	S1	M1LA4	128	W 75_25	P80	BN80A4	129
58	69	0.9	24	2080	—	—	—	—	VF 49_24	P80	BN80A4	118
58	71	2.2	24	3480	W 63_24	S1	M1LA4	124	W 63_24	P80	BN80A4	125
66	62	1.1	14	1960	—	—	—	—	VF 49_14	P80	BN80B6	118
73	59	2.6	19	3260	W 63_19	S1	M1LA4	124	W 63_19	P80	BN80A4	125
77	53	1.1	18	1930	—	—	—	—	VF 49_18	P80	BN80A4	118
92	47	1.4	10	1800	—	—	—	—	VF 49_10	P80	BN80B6	118
92	47	3.2	15	3050	W 63_15	S1	M1LA4	124	W 63_15	P80	BN80A4	125
99	43	1.5	14	1810	—	—	—	—	VF 49_14	P80	BN80A4	118
115	39	3.6	12	2850	W 63_12	S1	M1LA4	124	W 63_12	P80	BN80A4	125
117	35	1.3	24	1800	—	—	—	—	VF 49_24	P71	BN71B2	118
131	35	3.7	7	2700	W 63_7	S2	M2SA6	124	W 63_7	P80	BN80B6	125
138	32	1.8	10	1650	—	—	—	—	VF 49_10	P80	BN80A4	118
141	30	1.0	20	1490	—	—	—	—	VF 44_20	P71	BN71B2	112
156	28	1.6	18	1650	—	—	—	—	VF 49_18	P71	BN71B2	118
197	23	2.4	7	1480	—	—	—	—	VF 49_7	P80	BN80A4	118
281	16	1.4	10	1210	—	—	—	—	VF 44_10	P71	BN71B2	112
281	16	2.7	10	1390	—	—	—	—	VF 49_10	P71	BN71B2	118
401	12	1.9	7	1080	—	—	—	—	VF 44_7	P71	BN71B2	112







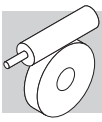

0.75 kW







n ₂ min-1	M ₂ Nm	S	i	R _{n2} N						IEC 		
0.29	4983	1.3	3200	34500	—	—	—	VF/VF 130/210_3200	P90	BN90S6	162	
0.29	4733	1.9	3200	52000	—	—	—	VF/VF 130/250_3200	P90	BN90S6	168	
0.36	4783	1.4	2560	34500	—	—	—	VF/VF 130/210_2560	P90	BN90S6	162	
0.36	4584	2.0	2560	52000	—	—	—	VF/VF 130/250_2560	P90	BN90S6	168	
0.44	3929	1.1	3200	19500	—	—	—	W/VF 86/185_3200	P80	BN80B4	157	
0.50	4584	1.0	1840	19500	—	—	—	W/VF 86/185_1840	P90	BN90S6	157	
0.50	4011	1.6	1840	34500	—	—	—	VF/VF 130/210_1840	P90	BN90S6	162	
0.50	4154	2.2	1840	52000	—	—	—	VF/VF 130/250_1840	P90	BN90S6	168	
0.55	3798	1.1	2560	19500	—	—	—	W/VF 86/185_2560	P80	BN80B4	157	
0.76	3201	1.3	1840	19500	—	—	—	W/VF 86/185_1840	P80	BN80B4	157	
0.88	2865	1.5	1600	19500	—	—	—	W/VF 86/185_1600	P80	BN80B4	157	
1.0	2722	1.6	920	19500	—	—	—	W/VF 86/185_920	P90	BN90S6	157	
1.2	2087	0.9	1200	13800	—	—	—	W/VF 63/130_1200	P80	BN80B4	145	
1.2	2087	2.0	1200	19500	—	—	—	W/VF 86/185_1200	P80	BN80B4	157	
1.3	2525	1.1	690	16000	—	—	—	W/VF 86/150_690	P90	BN90S6	151	
1.5	1817	1.0	960	13800	—	—	—	W/VF 63/130_960	P80	BN80B4	145	
1.5	2118	1.2	920	16000	—	—	—	W/VF 86/150_920	P80	BN80B4	151	
1.5	1977	2.1	920	19500	—	—	—	W/VF 86/185_920	P80	BN80B4	157	
1.7	2142	1.3	529	16000	—	—	—	W/VF 86/150_529	P90	BN90S6	151	
1.8	1760	2.4	800	19500	—	—	—	W/VF 86/185_800	P80	BN80B4	157	
1.8	1516	1.2	760	13800	—	—	—	W/VF 63/130_760	P80	BN80B4	145	
2.0	1765	1.5	690	16000	—	—	—	W/VF 86/150_690	P80	BN80B4	151	
2.3	1228	1.5	600	13800	—	—	—	W/VF 63/130_600	P80	BN80B4	145	
2.3	1381	3.0	600	19500	—	—	—	W/VF 86/185_600	P80	BN80B4	157	
2.6	1489	1.7	529	16000	—	—	—	W/VF 86/150_529	P80	BN80B4	151	
3.0	1294	2.0	460	16000	—	—	—	W/VF 86/150_460	P80	BN80B4	151	
3.1	1144	0.9	300	13800	—	—	—	VFR 130_300	P90	BN90S6	142	
3.1	1167	1.2	300	16000	—	—	—	VFR 150_300	P90	BN90S6	148	
3.1	1168	2.1	300	19500	—	—	—	VFR 185_300	P90	BN90S6	154	
3.5	921	1.1	400	8000	—	—	—	VF/W 49/110_400	P80	BN80B4	139	
3.5	900	2.0	400	13800	—	—	—	W/VF 63/130_400	P80	BN80B4	145	
3.8	1009	1.2	240	13800	—	—	—	VFR 130_240	P90	BN90S6	142	
3.8	1009	1.7	240	16000	—	—	—	VFR 150_240	P90	BN90S6	148	
3.8	1009	2.8	240	19500	—	—	—	VFR 185_240	P90	BN90S6	154	
4.1	1024	2.5	345	16000	—	—	—	W/VF 86/150_345	P80	BN80B4	151	
4.7	813	1.1	300	13800	—	—	—	VFR 130_300	P80	BN80B4	142	
4.7	737	1.4	300	8000	—	—	—	VF/W 49/110_300	P80	BN80B4	139	
4.7	890	2.9	300	16000	—	—	—	W/VF 86/150_300	P80	BN80B4	151	
4.8	882	2.2	192	16000	—	—	—	VFR 150_192	P90	BN90S6	148	
5.0	716	2.5	280	13800	—	—	—	W/VF 63/130_280	P80	BN80B4	145	
5.5	785	1.0	168	8000	—	—	—	WR 110_168	P90	BN90S6	138	
5.5	798	2.4	168	16000	—	—	—	VFR 150_168	P90	BN90S6	148	
5.8	700	1.6	240	13800	—	—	—	VFR 130_240	P80	BN80B4	142	
6.1	612	1.6	230	8000	—	—	—	VF/W 49/110_230	P80	BN80B4	139	
6.7	677	1.2	138	8000	—	—	—	WR 110_138	P90	BN90S6	138	
6.7	688	2.2	138	13800	—	—	—	VFR 130_138	P90	BN90S6	142	
6.7	688	3.2	138	16000	—	—	—	VFR 150_138	P90	BN90S6	148	
7.3	589	1.1	192	8000	—	—	—	WR 110_192	P80	BN80B4	138	
7.3	599	2.0	192	13800	—	—	—	VFR 130_192	P80	BN80B4	142	
8.3	541	1.3	168	8000	—	—	—	WR 110_168	P80	BN80B4	138	
8.3	550	2.2	168	13800	—	—	—	VFR 130_168	P80	BN80B4	142	
9.2	444	1.1	100	8000	W 110_100	S2	M2SB6	136	W 110_100	P90	BN90S6	137
9.2	459	1.7	100	13200	—	—	—	VF 130_100	P90	BN90S6	140	
10.1	445	0.9	138	7000	—	—	—	WR 86_138	P80	BN80B4	134	
10.1	466	1.5	138	8000	—	—	—	WR 110_138	P80	BN80B4	138	
10.1	473	2.9	138	13800	—	—	—	VFR 130_138	P80	BN80B4	142	
11.5	411	1.1	80	8000	W 110_80	S2	M2SB6	136	W 110_80	P90	BN90S6	137
11.5	399	2.4	80	13200	—	—	—	VF 130_80	P90	BN90S6	140	
11.7	405	1.0	120	7000	—	—	—	WR 86_120	P80	BN80B4	134	
11.7	417	1.9	120	8000	—	—	—	WR 110_120	P80	BN80B4	138	
11.7	411	3.4	120	13800	—	—	—	VFR 130_120	P80	BN80B4	142	
13.3	403	1.9	69	8000	—	—	—	WR 110_69	P90	BN90S6	138	
14.0	317	1.5	100	8000	W 110_100	S2	M2SA4	136	W 110_100	P80	BN80B4	137
14.4	314	1.0	64	7000	W 86_64	S2	M2SB6	132	W 86_64	P90	BN90S6	133
14.4	339	3.1	64	13200	—	—	—	VF 130_64	P90	BN90S6	140	



0.75 kW





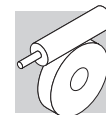

n ₂ min-1	M ₂ Nm	S	i	Rn ₂ N						IEC 		
15.6	318	1.0	90	6200	—	—	—	—	WR 75_90	P80	BN80B4	130
15.6	308	1.4	90	7000	—	—	—	—	WR 86_90	P80	BN80B4	134
15.6	322	2.6	90	8000	—	—	—	—	WR 110_90	P80	BN80B4	138
16.4	288	1.1	56	7000	W 86_56	S2	M2SB6	132	W 86_56	P90	BN90S6	133
16.4	296	2.2	56	8000	W 110_56	S2	M2SB6	136	W 110_56	P90	BN90S6	137
17.5	262	1.0	80	7000	W 86_80	S2	M2SA4	132	W 86_80	P80	BN80B4	133
17.5	270	1.7	80	8000	W 110_80	S2	M2SA4	136	W 110_80	P80	BN80B4	137
18.4	245	1.0	50	6200	W 75_50	S2	M2SB6	128	W 75_50	P90	BN90S6	129
18.7	280	1.1	75	5980	—	—	—	—	WR 75_75	P80	BN80B4	130
20.3	265	1.4	69	7000	—	—	—	—	WR 86_69	P80	BN80B4	134
20.3	272	2.4	69	8000	—	—	—	—	WR 110_69	P80	BN80B4	138
20.4	273	1.3	45	6010	—	—	—	—	WR 75_45	P90	BN90S6	130
21.9	223	1.3	64	7000	W 86_64	S2	M2SA4	132	W 86_64	P80	BN80B4	133
21.9	229	2.3	64	8000	W 110_64	S2	M2SA4	136	W 110_64	P80	BN80B4	137
23.0	212	1.3	40	5930	W 75_40	S2	M2SB6	128	W 75_40	P90	BN90S6	129
23.3	200	1.0	60	5960	W 75_60	S2	M2SA4	128	W 75_60	P80	BN80B4	129
23.3	236	1.2	60	5640	—	—	—	—	WR 75_60	P80	BN80B4	130
23.3	236	1.6	60	7000	—	—	—	—	WR 86_60	P80	BN80B4	134
23.3	243	2.8	60	8000	—	—	—	—	WR 110_60	P80	BN80B4	138
25.0	201	1.5	56	7000	W 86_56	S2	M2SA4	132	W 86_56	P80	BN80B4	133
25.0	206	2.9	56	8000	W 110_56	S2	M2SA4	136	W 110_56	P80	BN80B4	137
28.0	174	1.3	50	5670	W 75_50	S2	M2SA4	128	W 75_50	P80	BN80B4	129
30	172	2.0	46	7000	W 86_46	S2	M2SA4	132	W 86_46	P80	BN80B4	133
30	174	3.4	46	8000	W 110_46	S2	M2SA4	136	W 110_46	P80	BN80B4	137
31	154	0.9	45	3860	W 63_45	S2	M2SA4	124	W 63_45	P80	BN80B4	125
31	184	1.6	45	5250	—	—	—	—	WR 75_45	P80	BN80B4	130
31	180	2.2	45	7000	—	—	—	—	WR 86_45	P80	BN80B4	134
35	147	1.7	40	5370	W 75_40	S2	M2SA4	128	W 75_40	P80	BN80B4	129
35	153	2.2	40	7000	W 86_40	S2	M2SA4	132	W 86_40	P80	BN80B4	133
37	136	1.1	38	3700	W 63_38	S2	M2SA4	124	W 63_38	P80	BN80B4	125
40	143	2.4	23	7000	W 86_23	S2	M2SB6	132	W 86_23	P90	BN90S6	133
47	114	1.4	30	3490	W 63_30	S2	M2SA4	124	W 63_30	P80	BN80B4	125
47	129	2.1	30	4680	—	—	—	—	WR 75_30	P80	BN80B4	130
47	118	2.3	30	4950	W 75_30	S2	M2SA4	128	W 75_30	P80	BN80B4	129
47	117	3.2	30	7000	W 86_30	S2	M2SA4	132	W 86_30	P80	BN80B4	133
56	102	2.4	25	4700	W 75_25	S2	M2SA4	128	W 75_25	P80	BN80B4	129
58	96	1.6	24	3290	W 63_24	S2	M2SA4	124	W 63_24	P80	BN80B4	125
61	96	3.3	23	7000	W 86_23	S2	M2SA4	132	W 86_23	P80	BN80B4	133
70	85	2.9	20	4400	W 75_20	S2	M2SA4	128	W 75_20	P80	BN80B4	129
74	79	1.9	19	3100	W 63_19	S2	M2SA4	124	W 63_19	P80	BN80B4	125
93	64	2.4	15	2910	W 63_15	S2	M2SA4	124	W 63_15	P80	BN80B4	125
100	58	1.1	14	1690	—	—	—	—	VF 49_14	P80	BN80B4	118
117	49	1.0	24	1710	—	—	—	—	VF 49_24	P80	BN80A2	118
117	52	2.7	12	2740	W 63_12	S2	M2SA4	124	W 63_12	P80	BN80B4	125
131	47	2.7	7	2590	W 63_7	S2	M2SB6	124	W 63_7	P90	BN90S6	125
140	43	1.4	10	1540	—	—	—	—	VF 49_10	P80	BN80B4	118
140	44	3.2	10	2600	W 63_10	S2	M2SA4	124	W 63_10	P80	BN80B4	133
187	33	3.8	15	2440	W 63_15	S1	M1LA2	124	W 63_15	P80	BN80A2	125
200	31	1.8	7	1400	—	—	—	—	VF 49_7	P80	BN80B4	118
200	32	3.8	7	2340	W 63_7	S2	M2SA4	124	W 63_7	P80	BN80B4	125
280	22	2.0	10	1340	—	—	—	—	VF 49_10	P80	BN80A2	118
400	16	2.6	7	1200	—	—	—	—	VF 49_7	P80	BN80A2	118

1.1 kW

n ₂ min-1	M ₂ Nm	S	i	Rn ₂ N						IEC 		
0.29	7308	0.9	3200	34500	—	—	—	—	VF/VF 130/210_3200	P90	BN90L6	162
0.29	6942	1.3	3200	52000	—	—	—	—	VF/VF 130/250_3200	P90	BN90L6	168
0.36	7016	0.9	2560	34500	—	—	—	—	VF/VF 130/210_2560	P90	BN90L6	162
0.36	6723	1.4	2560	52000	—	—	—	—	VF/VF 130/250_2560	P90	BN90L6	168
0.44	5283	1.2	3200	34500	—	—	—	—	VF/VF 130/210_3200	P90	BN90S4	162







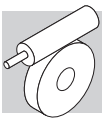

1.1 kW







n ₂ min-1	M ₂ Nm	S	i	R _{n2} N						IEC 		
0.44	5042	1.8	3200	52000	—	—	—	VF/VF 130/250_3200	P90	BN90S4	168	
0.50	7143	0.9	1840	34500	—	—	—	VF/VF 130/210_1840	P90	BN90L6	162	
0.50	6093	1.5	1840	52000	—	—	—	VF/VF 130/250_1840	P90	BN90L6	168	
0.55	4610	1.4	2560	34500	—	—	—	VF/VF 130/210_2560	P90	BN90S4	162	
0.55	4802	1.9	2560	52000	—	—	—	VF/VF 130/250_2560	P90	BN90S4	168	
0.76	4694	0.9	1840	19500	—	—	—	W/VF 86/185_1840	P90	BN90S4	157	
0.76	4832	1.3	1840	34500	—	—	—	VF/VF 130/210_1840	P90	BN90S4	162	
0.76	4280	2.1	1840	52000	—	—	—	VF/VF 130/250_1840	P90	BN90S4	168	
0.88	4202	1.0	1600	19500	—	—	—	W/VF 86/185_1600	P90	BN90S4	157	
1.0	3992	1.1	920	19500	—	—	—	W/VF 86/185_920	P90	BN90L6	157	
1.2	3061	1.4	1200	19500	—	—	—	W/VF 86/185_1200	P90	BN90S4	157	
1.5	2899	1.4	920	19500	—	—	—	W/VF 86/185_920	P90	BN90S4	157	
1.8	2581	1.6	800	19500	—	—	—	W/VF 86/185_800	P90	BN90S4	157	
2.0	2589	1.0	690	16000	—	—	—	W/VF 86/150_690	P90	BN90S4	151	
2.3	1801	1.0	600	13800	—	—	—	W/VF 63/130_600	P90	BN90S4	145	
2.3	2026	2.1	600	19500	—	—	—	W/VF 86/185_600	P90	BN90S4	157	
2.6	2183	1.2	529	16000	—	—	—	W/VF 86/150_529	P90	BN90S4	151	
3.0	1898	1.4	460	16000	—	—	—	W/VF 86/150_460	P90	BN90S4	151	
3.1	1713	1.4	300	19500	—	—	—	VFR 185_300	P90	BN90L6	154	
3.5	1321	1.4	400	13800	—	—	—	W/VF 63/130_400	P90	BN90S4	145	
3.5	1441	2.9	400	19500	—	—	—	W/VF 86/185_400	P90	BN90S4	157	
3.8	1480	1.1	240	16000	—	—	—	VFR 150_240	P90	BN90L6	148	
3.8	1480	1.9	240	19500	—	—	—	VFR 185_240	P90	BN90L6	154	
4.1	1501	1.7	345	16000	—	—	—	W/VF 86/150_345	P90	BN90S4	151	
4.7	1222	1.1	300	16000	—	—	—	VFR 150_300	P90	BN90S4	148	
4.7	1238	1.9	300	19500	—	—	—	VFR 185_300	P90	BN90S4	154	
4.7	1306	2.0	300	16000	—	—	—	W/VF 86/150_300	P90	BN90S4	151	
4.8	1272	1.0	192	13800	—	—	—	VFR 130_192	P90	BN90L6	142	
5.0	1051	1.7	280	13800	—	—	—	W/VF 63/130_280	P90	BN90S4	145	
5.8	1026	1.1	240	13800	—	—	—	VFR 130_240	P90	BN90S4	142	
5.8	1044	1.5	240	16000	—	—	—	VFR 150_240	P90	BN90S4	148	
5.8	1063	2.6	240	19500	—	—	—	VFR 185_240	P90	BN90S4	154	
6.2	1064	2.4	225	16000	—	—	—	W/VF 86/150_225	P90	BN90S4	151	
6.7	1008	1.5	138	13800	—	—	—	VFR 130_138	P90	BN90L6	142	
6.7	1008	2.2	138	16000	—	—	—	VFR 150_138	P90	BN90L6	148	
7.0	960	2.7	200	16000	—	—	—	W/VF 86/150_200	P90	BN90S4	151	
7.3	879	1.4	192	13800	—	—	—	VFR 130_192	P90	BN90S4	142	
7.3	893	1.9	192	16000	—	—	—	VFR 150_192	P90	BN90S4	148	
7.7	891	1.0	120	8000	—	—	—	WR 110_120	P90	BN90L6	138	
7.8	878	3.4	180	19500	—	—	—	VFR 185_180	P90	BN90S4	154	
8.3	807	1.5	168	13800	—	—	—	VFR 130_168	P90	BN90S4	142	
8.3	819	2.1	168	16000	—	—	—	VFR 150_168	P90	BN90S4	148	
9.2	674	1.2	100	13200	—	—	—	VF 130_100	P90	BN90L6	140	
10.1	683	1.0	138	8000	—	—	—	WR 110_138	P90	BN90S4	138	
10.1	694	1.9	138	13800	—	—	—	VFR 130_138	P90	BN90S4	142	
10.1	704	2.8	138	16000	—	—	—	VFR 150_138	P90	BN90S4	148	
10.2	678	1.3	90	8000	—	—	—	WR 110_90	P90	BN90L6	138	
11.5	585	1.6	80	13200	—	—	—	VF 130_80	P90	BN90L6	140	
11.7	612	1.3	120	8000	—	—	—	WR 110_120	P90	BN90S4	138	
11.7	603	2.3	120	13800	—	—	—	VFR 130_120	P90	BN90S4	142	
11.7	612	3.3	120	16000	—	—	—	VFR 150_120	P90	BN90S4	148	
14.0	465	1.0	100	8000	W 110_100	S2	M2SB4	136	W 110_100	P90	BN90S4	137
14.0	525	1.1	100	12600	—	—	—	VF 130_100	P90	BN90S4	140	
15.6	473	1.8	90	8000	—	—	—	WR 110_90	P90	BN90S4	138	
15.6	479	3.1	90	13800	—	—	—	VFR 130_90	P90	BN90S4	142	
17.5	396	1.2	80	8000	W 110_80	S2	M2SB4	136	W 110_80	P90	BN90S4	137
17.5	408	2.2	80	12600	—	—	—	VF 130_80	P90	BN90S4	140	
20.0	362	1.0	46	7000	W 86_46	S3	M3SA6	132	W 86_46	P90	BN90L6	133
20.0	383	3.0	46	13200	—	—	—	VF 130_46	P90	BN90L6	140	
20.3	388	1.0	69	7000	—	—	—	WR 86_69	P90	BN90S4	134	
20.3	399	1.6	69	8000	—	—	—	WR 110_69	P90	BN90S4	138	
20.3	393	3.3	69	13800	—	—	—	VFR 130_69	P90	BN90S4	142	
21.9	336	1.6	64	8000	W 110_64	S2	M2SB4	136	W 110_64	P90	BN90S4	137
21.9	341	2.7	64	12600	—	—	—	VF 130_64	P90	BN90S4	140	
23.0	324	1.1	40	7000	W 86_40	S3	M3SA6	132	W 86_40	P90	BN90L6	133



1.1 kW





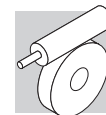

n ₂ min-1	M ₂ Nm	S	i	R _{n2} N						IEC 		
23.3	347	1.1	60	7000	—	—	—	—	WR 86_60	P90	BN90S4	134
23.3	356	1.9	60	8000	—	—	—	—	WR 110_60	P90	BN90S4	138
25.0	294	1.0	56	7000	W 86_56	S2	M2SB4	132	W 86_56	P90	BN90S4	133
25.0	303	2.0	56	8000	W 110_56	S2	M2SB4	136	W 110_56	P90	BN90S4	137
25.0	307	3.1	56	12600	—	—	—	—	VF 130_56	P90	BN90S4	140
30	252	1.3	46	7000	W 86_46	S2	M2SB4	132	W 86_46	P90	BN90S4	133
30	255	2.3	46	8000	W 110_46	S2	M2SB4	136	W 110_46	P90	BN90S4	137
31	270	1.1	45	5010	—	—	—	—	WR 75_45	P90	BN90S4	130
31	263	1.5	45	7000	—	—	—	—	WR 86_45	P90	BN90S4	134
31	270	2.6	45	8000	—	—	—	—	WR 110_45	P90	BN90S4	138
35	216	1.2	40	4980	W 75_40	S2	M2SB4	128	W 75_40	P90	BN90S4	129
35	225	1.5	40	7000	W 86_40	S2	M2SB4	132	W 86_40	P90	BN90S4	133
35	228	2.9	40	8000	W 110_40	S2	M2SB4	136	W 110_40	P90	BN90S4	137
37	217	1.2	37.5	4790	—	—	—	—	WR 75_37.5	P90	BN90S4	130
40	210	1.6	23	7000	W 86_23	S3	M3SA6	132	W 86_23	P90	BN90L6	133
41	207	1.7	34.5	7000	—	—	—	—	WR 86_34.5	P90	BN90S4	134
47	167	1.0	30	3130	W 63_30	S2	M2SB4	124	W 63_30	P90	BN90S4	125
47	189	1.5	30	4530	—	—	—	—	WR 75_30	P90	BN90S4	130
47	173	1.6	30	4640	W 75_30	S2	M2SB4	128	W 75_30	P90	BN90S4	129
47	185	1.9	30	7000	—	—	—	—	WR 86_30	P90	BN90S4	134
47	171	2.2	30	7000	W 86_30	S2	M2SB4	132	W 86_30	P90	BN90S4	133
56	150	1.7	25	4420	W 75_25	S2	M2SB4	128	W 75_25	P90	BN90S4	129
58	140	1.1	24	2990	W 63_24	S2	M2SB4	124	W 63_24	P90	BN90S4	125
61	142	2.3	23	7000	W 86_23	S2	M2SB4	132	W 86_23	P90	BN90S4	133
70	125	2.0	20	4160	W 75_20	S2	M2SB4	128	W 75_20	P90	BN90S4	129
70	126	2.5	20	7000	W 86_20	S2	M2SB4	132	W 86_20	P90	BN90S4	133
74	115	1.3	19	2840	W 63_19	S2	M2SB4	124	W 63_19	P90	BN90S4	125
93	93	1.6	15	2690	W 63_15	S2	M2SB4	124	W 63_15	P90	BN90S4	125
93	96	2.6	15	3850	W 75_15	S2	M2SB4	128	W 75_15	P90	BN90S4	129
93	96	3.4	15	6820	W 86_15	S2	M2SB4	132	W 86_15	P90	BN90S4	133
117	77	1.8	12	2550	W 63_12	S2	M2SB4	124	W 63_12	P90	BN90S4	125
140	65	2.2	10	2440	W 63_10	S2	M2SB4	124	W 63_10	P90	BN90S4	125
140	66	3.5	10	3420	W 75_10	S2	M2SB4	128	W 75_10	P90	BN90S4	129
187	48	2.6	15	2330	W 63_15	S2	M2SA2	124	W 63_15	P80	BN80B2	125
200	44	1.1	14	1370	—	—	—	—	VF 49_14	P80	BN80B2	118
200	46	2.6	7	2210	W 63_7	S2	M2SB4	124	W 63_7	P90	BN90S4	125
233	39	3.2	12	2190	W 63_12	S2	M2SA2	124	W 63_12	P80	BN80B2	125
280	32	1.4	10	1250	—	—	—	—	VF 49_10	P80	BN80B2	118
280	33	3.8	10	2080	W 63_10	S2	M2SA2	124	W 63_10	P80	BN80B2	125
400	23	1.8	7	1130	—	—	—	—	VF 49_7	P80	BN80B2	118

1.5 kW

n ₂ min-1	M ₂ Nm	S	i	R _{n2} N						IEC 		
0.29	9266	1.0	3200	52000	—	—	—	—	VF/VF 130/250_3200	P100	BN100LA6	168
0.37	8973	1.0	2560	52000	—	—	—	—	VF/VF 130/250_2560	P100	BN100LA6	168
0.44	7152	0.9	3200	34500	—	—	—	—	VF/VF 130/210_3200	P90	BN90LA4	162
0.44	6827	1.3	3200	52000	—	—	—	—	VF/VF 130/250_3200	P90	BN90LA4	168
0.51	8132	1.1	1840	52000	—	—	—	—	VF/VF 130/250_1840	P100	BN100LA6	168
0.55	6242	1.0	2560	34500	—	—	—	—	VF/VF 130/210_2560	P90	BN90LA4	162
0.55	6502	1.4	2560	52000	—	—	—	—	VF/VF 130/250_2560	P90	BN90LA4	168
0.77	6543	1.0	1840	34500	—	—	—	—	VF/VF 130/210_1840	P90	BN90LA4	162
0.77	5795	1.6	1840	52000	—	—	—	—	VF/VF 130/250_1840	P90	BN90LA4	168
1.0	4907	1.3	920	34500	—	—	—	—	VF/VF 130/210_920	P100	BN100LA6	162
1.0	4907	1.9	920	52000	—	—	—	—	VF/VF 130/250_920	P100	BN100LA6	168
1.2	4145	1.0	1200	19500	—	—	—	—	W/VF 86/185_1200	P90	BN90LA4	157
1.2	4633	1.4	800	34500	—	—	—	—	VF/VF 130/210_800	P100	BN100LA6	162
1.2	4877	1.9	800	52000	—	—	—	—	VF/VF 130/250_800	P100	BN100LA6	168
1.5	3926	1.1	920	19500	—	—	—	—	W/VF 86/185_920	P90	BN90LA4	157
1.6	3932	1.7	600	34500	—	—	—	—	VF/VF 130/210_600	P100	BN100LA6	162
1.6	3932	2.3	600	52000	—	—	—	—	VF/VF 130/250_600	P100	BN100LA6	168







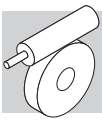

1.5 kW







n ₂ min-1	M ₂ Nm	S	i	R _{n2} N						IEC 		
1.8	3495	1.2	800	19500	—	—	—	W/VF 86/185_800	P90	BN90LA4	157	
2.4	2743	1.5	600	19500	—	—	—	W/VF 86/185_600	P90	BN90LA4	157	
2.4	2926	2.2	400	34500	—	—	—	VF/VF 130/210_400	P100	BN100LA6	162	
2.4	2865	3.2	400	52000	—	—	—	VF/VF 130/250_400	P100	BN100LA6	168	
2.7	2956	0.9	529	16000	—	—	—	W/VF 86/150_529	P90	BN90LA4	151	
3.1	2570	1.0	460	16000	—	—	—	W/VF 86/150_460	P90	BN90LA4	151	
3.1	2286	1.0	300	19500	—	—	—	VFR 185_300	P100	BN100LA6	154	
3.1	2240	1.6	300	34500	—	—	—	VFR 210_300	P100	BN100LA6	160	
3.1	2377	2.2	300	52000	—	—	—	VFR 250_300	P100	BN100LA6	166	
3.4	2134	3.0	280	34500	—	—	—	VF/VF 130/210_280	P100	BN100LA6	162	
3.5	1788	1.0	400	13800	—	—	—	W/VF 63/130_400	P90	BN90LA4	145	
3.5	1951	2.2	400	19500	—	—	—	W/VF 86/185_400	P90	BN90LA4	157	
3.9	1975	0.9	240	16000	—	—	—	VFR 150_240	P100	BN100LA6	148	
3.9	1975	1.4	240	19500	—	—	—	VFR 185_240	P100	BN100LA6	154	
3.9	1975	2.2	240	34500	—	—	—	VFR 210_240	P100	BN100LA6	160	
3.9	2048	2.8	240	52000	—	—	—	VFR 250_240	P100	BN100LA6	166	
4.1	2033	1.3	345	16000	—	—	—	W/VF 86/150_345	P90	BN90LA4	151	
4.7	1676	1.4	300	19500	—	—	—	VFR 185_300	P90	BN90LA4	154	
4.7	1768	1.5	300	16000	—	—	—	W/VF 86/150_300	P90	BN90LA4	151	
4.9	1726	1.1	192	16000	—	—	—	VFR 150_192	P100	BN100LA6	148	
5.0	1422	1.3	280	13800	—	—	—	W/VF 63/130_280	P90	BN90LA4	145	
5.0	1479	2.8	280	19500	—	—	—	W/VF 86/185_280	P90	BN90LA4	157	
5.2	1646	2.0	180	19500	—	—	—	VFR 185_180	P100	BN100LA6	154	
5.2	1481	3.3	180	34500	—	—	—	VFR 210_180	P100	BN100LA6	160	
5.6	1536	0.9	168	13800	—	—	—	VFR 130_168	P100	BN100LA6	142	
5.9	1414	1.1	240	16000	—	—	—	VFR 150_240	P90	BN90LA4	148	
5.9	1439	1.9	240	19500	—	—	—	VFR 185_240	P90	BN90LA4	154	
6.3	1440	1.8	225	16000	—	—	—	W/VF 86/150_225	P90	BN90LA4	151	
7.1	1300	2.0	200	16000	—	—	—	W/VF 86/150_200	P90	BN90LA4	151	
7.3	1190	1.0	192	13800	—	—	—	VFR 130_192	P90	BN90LA4	142	
7.3	1209	1.4	192	16000	—	—	—	VFR 150_192	P90	BN90LA4	148	
7.8	1189	2.5	180	19500	—	—	—	VFR 185_180	P90	BN90LA4	154	
8.4	1092	1.1	168	13800	—	—	—	VFR 130_168	P90	BN90LA4	142	
8.4	1109	1.6	168	16000	—	—	—	VFR 150_168	P90	BN90LA4	148	
9.4	930	1.2	100	15500	—	—	—	VF 150_100	P100	BN100LA6	146	
9.4	945	2.1	100	19500	—	—	—	VF 185_100	P100	BN100LA6	152	
9.4	1021	3.2	150	16000	—	—	—	VFR 185_150	P90	BN90LA4	154	
10.2	939	1.4	138	13800	—	—	—	VFR 130_138	P90	BN90LA4	142	
10.2	953	2.1	138	16000	—	—	—	VFR 150_138	P90	BN90LA4	148	
10.4	905	1.0	90	8000	—	—	—	WR 110_90	P100	BN100LA6	138	
10.4	1001	3.2	90	19500	—	—	—	VFR 185_90	P100	BN100LA6	154	
11.8	829	1.0	120	8000	—	—	—	WR 110_120	P90	BN90LA4	138	
11.8	780	1.2	80	13200	—	—	—	VF 130_80	P100	BN100LA6	140	
11.8	792	1.7	80	15500	—	—	—	VF 150_80	P100	BN100LA6	146	
11.8	817	1.7	120	13800	—	—	—	VFR 130_120	P90	BN90LA4	142	
11.8	829	2.4	120	16000	—	—	—	VFR 150_120	P90	BN90LA4	148	
11.8	805	3.0	80	19000	—	—	—	VF 185_80	P100	BN100LA6	152	
13.6	789	1.0	69	8000	—	—	—	WR 110_69	P100	BN100LA6	138	
13.6	778	1.9	69	13800	—	—	—	VFR 130_69	P100	BN100LA6	142	
13.6	778	2.6	69	16000	—	—	—	VFR 150_69	P100	BN100LA6	148	
14.7	673	2.2	64	15500	—	—	—	VF 150_64	P100	BN100LA6	146	
15.7	640	1.3	90	8000	—	—	—	WR 110_90	P90	BN90LA4	138	
15.7	649	2.3	90	13800	—	—	—	VFR 130_90	P90	BN90LA4	142	
15.7	658	3.0	90	16000	—	—	—	VFR 150_90	P90	BN90LA4	148	
16.8	580	1.1	56	8000	W 110_56	S3	M3LA6	136	W 110_56	P100	BN100LA6	137
16.8	597	1.8	56	13200	—	—	—	VF 130_56	P100	BN100LA6	140	
16.8	606	2.5	56	15500	—	—	—	VF 150_56	P100	BN100LA6	146	
17.6	553	1.6	80	12600	—	—	—	VF 130_80	P90	BN90LA4	140	
20.4	540	1.2	69	8000	—	—	—	WR 110_69	P90	BN90LA4	138	
20.4	498	1.3	46	8000	W 110_46	S3	M3LA6	136	W 110_46	P100	BN100LA6	137
20.4	533	2.4	69	13800	—	—	—	VFR 130_69	P90	BN90LA4	142	
20.4	519	3.4	46	15500	—	—	—	VF 150_46	P100	BN100LA6	146	
20.4	540	3.4	69	16000	—	—	—	VFR 150_69	P90	BN90LA4	148	
22.0	455	1.2	64	8000	W 110_64	S3	M3SA4	136	W 110_64	P90	BN90LA4	137
22.0	462	2.0	64	12600	—	—	—	VF 130_64	P90	BN90LA4	140	



1.5 kW





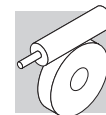

n ₂ min-1	M ₂ Nm	S	i	R _{n2} N						IEC 		
23.5	482	1.4	60	8000	—	—	—	—	WR 110_60	P90	BN90LA4	138
23.5	445	2.7	40	13200	—	—	—	—	VF 130_40	P100	BN100LA6	140
23.5	475	2.8	60	13800	—	—	—	—	VFR 130_60	P90	BN90LA4	142
25.2	410	1.5	56	8000	W 110_56	S3	M3SA4	136	W 110_56	P90	BN90LA4	137
25.2	415	2.3	56	12600	—	—	—	—	VF 130_56	P90	BN90LA4	140
31	341	1.0	46	7000	W 86_46	S3	M3SA4	132	W 86_46	P90	BN90LA4	133
31	346	1.7	46	8000	W 110_46	S3	M3SA4	136	W 110_46	P90	BN90LA4	137
31	355	3.0	46	12600	—	—	—	—	VF 130_46	P90	BN90LA4	140
31	357	1.1	45	7000	—	—	—	—	WR 86_45	P90	BN90LA4	134
31	366	1.9	45	8000	—	—	—	—	WR 110_45	P90	BN90LA4	138
35	305	1.1	40	7000	W 86_40	S3	M3SA4	132	W 86_40	P90	BN90LA4	133
35	309	2.2	40	8000	W 110_40	S3	M3SA4	136	W 110_40	P90	BN90LA4	137
38	293	0.9	37.5	4330	—	—	—	—	WR 75_37.5	P90	BN90LA4	130
38	293	0.9	25	4330	W 75_25	S3	M3LA6	128	W 75_25	P100	BN100LA6	129
41	280	1.2	34.5	7000	—	—	—	—	WR 86_34.5	P90	BN90LA4	134
41	280	1.2	23	7000	W 86_23	S3	M3LA6	132	W 86_23	P100	BN100LA6	133
47	256	1.1	30	4130	—	—	—	—	WR 75_30	P90	BN90LA4	130
47	235	1.2	30	4270	W 75_30	S3	M3SA4	128	W 75_30	P90	BN90LA4	129
47	250	1.4	30	7000	—	—	—	—	WR 86_30	P90	BN90LA4	134
47	232	1.6	30	7000	W 86_30	S3	M3SA4	132	W 86_30	P90	BN90LA4	133
47	235	3.0	30	8000	W 110_30	S3	M3SA4	136	W 110_30	P90	BN90LA4	137
56	203	1.2	25	4100	W 75_25	S3	M3SA4	128	W 75_25	P90	BN90LA4	129
61	192	1.7	23	7000	W 86_23	S3	M3SA4	132	W 86_23	P90	BN90LA4	133
61	194	2.8	23	8000	W 110_23	S3	M3SA4	136	W 110_23	P90	BN90LA4	137
71	169	1.5	20	3880	W 75_20	S3	M3SA4	128	W 75_20	P90	BN90LA4	129
71	171	1.9	20	7000	W 86_20	S3	M3SA4	132	W 86_20	P90	BN90LA4	133
71	171	3.3	20	8000	W 110_20	S3	M3SA4	136	W 110_20	P90	BN90LA4	137
74	156	1.0	19	2550	—	—	—	—	W 63_19	P90	BN90LA4	125
94	126	1.2	15	2450	—	—	—	—	W 63_15	P90	BN90LA4	125
94	130	1.9	15	3630	W 75_15	S3	M3SA4	128	W 75_15	P90	BN90LA4	129
94	131	2.4	15	6520	—	—	—	—	WR 86_15	P90	BN90LA4	134
94	130	2.5	15	6610	W 86_15	S3	M3SA4	132	W 86_15	P90	BN90LA4	133
118	104	1.4	12	2340	—	—	—	—	W 63_12	P90	BN90LA4	125
134	94	2.2	7	3150	W 75_7	S3	M3LA6	128	W 75_7	P100	BN100LA6	129
141	87	1.6	10	2250	—	—	—	—	W 63_10	P90	BN90LA4	125
141	89	2.6	10	3250	W 75_10	S3	M3SA4	128	W 75_10	P90	BN90LA4	129
141	89	3.2	10	5850	W 86_10	S3	M3SA4	132	W 86_10	P90	BN90LA4	133
187	66	1.9	15	2200	W 63_15	S2	M2SB2	124	W 63_15	P90	BN90SA2	125
187	68	3.3	15	3120	W 75_15	S2	M2SB2	128	W 75_15	P90	BN90SA2	129
201	63	1.9	7	2060	—	—	—	—	W 63_7	P90	BN90LA4	125
201	64	3.0	7	2920	W 75_7	S3	M3SA4	128	W 75_7	P90	BN90LA4	129
201	63	3.9	7	5240	W 86_7	S3	M3SA4	132	W 86_7	P90	BN90LA4	133
233	53	2.3	12	2080	W 63_12	S2	M2SB2	124	W 63_12	P90	BN90SA2	125
280	45	2.8	10	1980	W 63_10	S2	M2SB2	124	W 63_10	P90	BN90SA2	125

1.85 kW

n ₂ min-1	M ₂ Nm	S	i	R _{n2} N						IEC 		
0.44	8480	1.1	3200	52000	—	—	—	—	VF/VF 130/250_3200	P90	BN90LB4	168
0.55	8077	1.1	2560	52000	—	—	—	—	VF/VF 130/250_2560	P90	BN90LB4	168
0.76	7198	1.3	1840	52000	—	—	—	—	VF/VF 130/250_1840	P90	BN90LB4	168
1.0	6117	1.1	920	34500	—	—	—	—	VF/VF 130/210_920	P100	BN100LB6	162
1.0	6117	1.5	920	52000	—	—	—	—	VF/VF 130/250_920	P100	BN100LB6	168
1.2	5775	1.1	800	34500	—	—	—	—	VF/VF 130/210_800	P100	BN100LB6	162
1.2	6079	1.5	800	52000	—	—	—	—	VF/VF 130/250_800	P100	BN100LB6	168
1.6	4901	1.3	600	34500	—	—	—	—	VF/VF 130/210_600	P100	BN100LB6	162
1.6	4901	1.9	600	52000	—	—	—	—	VF/VF 130/250_600	P100	BN100LB6	168
1.8	4341	1.0	800	19500	—	—	—	—	W /VF 86/185_800	P90	BN90LB4	157
2.3	3647	1.8	400	34500	—	—	—	—	VF/VF 130/210_400	P100	BN100LB6	162
2.3	3571	2.6	400	52000	—	—	—	—	VF/VF 130/250_400	P100	BN100LB6	168
2.3	3407	1.2	600	19500	—	—	—	—	W /VF 86/185_600	P90	BN90LB4	157







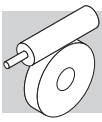

1.85 kW







n ₂ min-1	M ₂ Nm	S	i	R _{n2} N						IEC 		
3.1	2793	1.3	300	34500	—	—	—	VFR 210_300	P100	BN100LB6	160	
3.1	2964	1.8	300	52000	—	—	—	VFR 250_300	P100	BN100LB6	166	
3.3	2660	2.4	280	34500	—	—	—	VF/VF 130/210_280	P100	BN100LB6	162	
3.3	2713	3.4	280	52000	—	—	—	VF/VF 130/250_280	P100	BN100LB6	168	
3.5	2423	1.7	400	19500	—	—	—	W/VF 86/185_400	P90	BN90LB4	157	
3.9	2462	1.1	240	19500	—	—	—	VFR 185_240	P100	BN100LB6	154	
3.9	2462	1.8	240	34500	—	—	—	VFR 210_240	P100	BN100LB6	160	
3.9	2553	2.3	240	52000	—	—	—	VFR 250_240	P100	BN100LB6	166	
4.1	2525	1.0	345	16000	—	—	—	W/VF 86/150_345	P90	BN90LB4	151	
4.7	2082	1.1	300	19500	—	—	—	VFR 185_300	P90	BN90LB4	154	
4.7	2196	1.2	300	16000	—	—	—	W/VF 86/150_300	P90	BN90LB4	151	
4.8	2152	0.9	192	16000	—	—	—	VFR 150_192	P100	BN100LB6	148	
5.0	1767	1.0	280	13800	—	—	—	W/VF 63/130_280	P90	BN90LB4	145	
5.0	1837	2.3	280	19500	—	—	—	W/VF 86/185_280	P90	BN90LB4	157	
5.2	2052	1.6	180	19500	—	—	—	VFR 185_180	P100	BN100LB6	154	
5.2	1847	2.7	180	34500	—	—	—	VFR 210_180	P100	BN100LB6	160	
5.2	2120	3.2	180	52000	—	—	—	VFR 250_180	P100	BN100LB6	166	
5.8	1757	0.9	240	16000	—	—	—	VFR 150_240	P90	BN90LB4	148	
5.8	1787	1.6	240	19500	—	—	—	VFR 185_240	P90	BN90LB4	154	
6.2	1767	3.0	150	34500	—	—	—	VFR 210_150	P100	BN100LB6	160	
6.2	1789	1.5	225	16000	—	—	—	W/VF 86/150_225	P90	BN90LB4	151	
6.7	1678	0.9	138	13800	—	—	—	VFR 130_138	P100	BN100LB6	142	
6.7	1678	1.3	138	16000	—	—	—	VFR 150_138	P100	BN100LB6	148	
7.0	1615	1.6	200	16000	—	—	—	W/VF 86/150_200	P90	BN90LB4	151	
7.3	1502	1.1	192	16000	—	—	—	VFR 150_192	P90	BN90LB4	148	
7.8	1476	2.0	180	19500	—	—	—	VFR 185_180	P90	BN90LB4	154	
8.3	1357	0.9	168	13800	—	—	—	VFR 130_168	P90	BN90LB4	142	
8.3	1378	1.3	168	16000	—	—	—	VFR 150_168	P90	BN90LB4	148	
9.3	1159	1.0	100	15500	—	—	—	VF 150_100	P100	BN100LB6	146	
9.3	1178	1.7	100	19000	—	—	—	VF 185_100	P100	BN100LB6	152	
9.3	1268	2.6	150	19500	—	—	—	VFR 185_150	P90	BN90LB4	154	
10.1	1167	1.2	138	13800	—	—	—	VFR 130_138	P90	BN90LB4	142	
10.1	1184	1.7	138	16000	—	—	—	VFR 150_138	P90	BN90LB4	148	
11.6	973	1.0	80	13200	—	—	—	VF 130_80	P100	BN100LB6	140	
11.6	988	1.4	80	15500	—	—	—	VF 150_80	P100	BN100LB6	146	
11.6	1003	2.4	80	19000	—	—	—	VF 185_80	P100	BN100LB6	152	
11.7	1015	1.4	120	13800	—	—	—	VFR 130_120	P90	BN90LB4	142	
11.7	1030	1.9	120	16000	—	—	—	VFR 150_120	P90	BN90LB4	148	
11.7	1060	3.4	120	19500	—	—	—	VFR 185_120	P90	BN90LB4	154	
13.5	970	1.5	69	13800	—	—	—	VFR 130_69	P100	BN100LB6	142	
13.5	970	2.1	69	16000	—	—	—	VFR 150_69	P100	BN100LB6	148	
14.5	839	1.7	64	15500	—	—	—	VF 150_64	P100	BN100LB6	146	
15.6	795	1.0	90	8000	—	—	—	WR 110_90	P90	BN90LB4	138	
15.6	806	1.9	90	13800	—	—	—	VFR 130_90	P90	BN90LB4	142	
15.6	818	2.4	90	16000	—	—	—	VFR 150_90	P90	BN90LB4	148	
15.6	863	3.2	90	19500	—	—	—	VFR 185_90	P90	BN90LB4	154	
16.6	755	2.0	56	15500	—	—	—	VF 150_56	P100	BN100LB6	146	
17.5	687	1.3	80	12600	—	—	—	VF 130_80	P90	BN90LB4	140	
20.2	647	2.7	46	15500	—	—	—	VF 150_46	P100	BN100LB6	146	
20.3	670	1.0	69	8000	—	—	—	WR 110_69	P90	BN90LB4	138	
20.3	662	2.0	69	13800	—	—	—	VFR 130_69	P90	BN90LB4	142	
20.3	670	2.8	69	16000	—	—	—	VFR 150_69	P90	BN90LB4	148	
21.9	565	0.9	64	8000	—	—	—	W 110_64	P90	BN90LB4	137	
21.9	573	1.6	64	12600	—	—	—	VF 130_64	P90	BN90LB4	140	
23.3	555	1.3	40	8000	W 110_40	S3	M3LB6	136	W 110_40	P100	BN100LB6	137
23.3	562	3.1	40	15500	—	—	—	VF 150_40	P100	BN100LB6	146	
23.3	598	1.1	60	8000	—	—	—	WR 110_60	P90	BN90LB4	138	
23.3	591	2.3	60	13800	—	—	—	VFR 130_60	P90	BN90LB4	142	
23.3	598	3.2	60	16000	—	—	—	VFR 150_60	P90	BN90LB4	148	
25.0	509	1.2	56	8000	—	—	—	W 110_56	P90	BN90LB4	137	
25.0	516	1.9	56	12600	—	—	—	VF 130_56	P90	BN90LB4	140	
30	430	1.4	46	8000	—	—	—	W 110_46	P90	BN90LB4	137	
30	441	2.4	46	12600	—	—	—	VF 130_46	P90	BN90LB4	140	
31	416	1.0	30	7000	W 86_30	S3	M3LB6	132	W 86_30	P100	BN100LB6	133
31	443	0.9	45	7000	—	—	—	WR 86_45	P90	BN90LB4	134	



1.85 kW





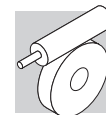

n ₂ min-1	M ₂ Nm	S	i	R _{n2} N						IEC 		
31	454	1.6	45	8000	—	—	—	—	WR 110_45	P90	BN90LB4	138
35	384	1.7	40	8000	—	—	—	—	W 110_40	P90	BN90LB4	137
40	350	1.0	23	7000	W 86_23	S3	M3LB6	132	W 86_23	P100	BN100LB6	133
40	354	3.0	23	13200	—	—	—	—	VF 130_23	P100	BN100LB6	140
41	348	1.0	34.5	7000	—	—	—	—	WR 86_34.5	P90	BN90LB4	134
42	339	3.1	69	13800	—	—	—	—	VFR 130_69	P90	BN90SB2	142
47	308	1.1	20	7000	W 86_20	S3	M3LB6	132	W 86_20	P100	BN100LB6	133
47	312	3.4	20	13200	—	—	—	—	VF 130_20	P100	BN100LB6	140
47	292	0.9	30	3960	—	—	—	—	W 75_30	P90	BN90LB4	129
47	310	1.1	30	7000	—	—	—	—	WR 86_30	P90	BN90LB4	134
47	288	1.3	30	7000	—	—	—	—	W 86_30	P90	BN90LB4	133
47	318	2.1	30	8000	—	—	—	—	WR 110_30	P90	BN90LB4	138
47	292	2.4	30	8000	—	—	—	—	W 110_30	P90	BN90LB4	137
56	252	1.0	25	3820	—	—	—	—	W 75_25	P90	BN90LB4	129
61	238	1.3	23	7000	—	—	—	—	W 86_23	P90	BN90LB4	133
61	241	2.2	23	8000	—	—	—	—	W 110_23	P90	BN90LB4	137
62	237	1.1	15	3600	W 75_15	S3	M3LB6	128	W 75_15	P100	BN100LB6	129
62	234	1.5	15	7000	W 86_15	S3	M3LB6	132	W 86_15	P100	BN100LB6	133
67	228	2.6	21	8000	—	—	—	—	WR 110_21	P90	BN90LB4	138
70	209	1.2	20	3650	—	—	—	—	W 75_20	P90	BN90LB4	129
70	212	1.5	20	6960	—	—	—	—	W 86_20	P90	BN90LB4	133
70	212	2.7	20	8000	—	—	—	—	W 110_20	P90	BN90LB4	137
93	163	1.5	10	3280	W 75_10	S3	M3LB6	128	W 75_10	P100	BN100LB6	129
93	157	1.0	15	2230	—	—	—	—	W 63_15	P90	BN90LB4	125
93	161	1.6	15	3440	—	—	—	—	W 75_15	P90	BN90LB4	129
93	161	2.1	15	6450	—	—	—	—	W 86_15	P90	BN90LB4	133
117	129	1.1	12	2150	—	—	—	—	W 63_12	P90	BN90LB4	125
133	117	1.8	7	2970	W 75_7	S3	M3LB6	128	W 75_7	P100	BN100LB6	129
133	117	2.3	7	5700	W 86_7	S3	M3LB6	132	W 86_7	P100	BN100LB6	133
140	109	1.3	10	2090	—	—	—	—	W 63_10	P90	BN90LB4	125
140	111	2.1	10	3100	—	—	—	—	W 75_10	P90	BN90LB4	129
140	111	2.6	10	5730	—	—	—	—	W 86_10	P90	BN90LB4	133
192	79	1.6	15	2080	—	—	—	—	W 63_15	P90	BN90SB2	125
192	81	2.8	15	3000	—	—	—	—	W 75_15	P90	BN90SB2	129
200	78	1.5	7	1930	—	—	—	—	W 63_7	P90	BN90LB4	125
200	80	2.4	7	2790	—	—	—	—	W 75_7	P90	BN90LB4	129
200	79	3.2	7	5140	—	—	—	—	W 86_7	P90	BN90LB4	133
240	64	2.0	12	1980	—	—	—	—	W 63_12	P90	BN90SB2	125
288	54	2.3	10	1890	—	—	—	—	W 63_10	P90	BN90SB2	125
288	55	3.7	10	2670	—	—	—	—	W 75_10	P90	BN90SB2	129
411	39	2.7	7	1720	—	—	—	—	W 63_7	P90	BN90SB2	125

2.2 kW

n ₂ min-1	M ₂ Nm	S	i	R _{n2} N						IEC 		
0.44	10013	0.9	3200	52000	—	—	—	—	VF/VF 130/250_3200	P100	BN100LA4	168
0.55	9536	0.9	2560	52000	—	—	—	—	VF/VF 130/250_2560	P100	BN100LA4	168
0.77	8499	1.1	1840	52000	—	—	—	—	VF/VF 130/250_1840	P100	BN100LA4	168
0.88	7629	1.2	1600	52000	—	—	—	—	VF/VF 130/250_1600	P100	BN100LA4	168
1.0	7197	0.9	920	34500	—	—	—	—	VF/VF 130/210_920	P112	BN112M6	162
1.0	7197	1.3	920	52000	—	—	—	—	VF/VF 130/250_920	P112	BN112M6	168
1.2	6258	1.0	1200	34500	—	—	—	—	VF/VF 130/210_1200	P100	BN100LA4	162
1.2	6258	1.4	1200	52000	—	—	—	—	VF/VF 130/250_1200	P100	BN100LA4	168
1.5	5072	1.2	920	34500	—	—	—	—	VF/VF 130/210_920	P100	BN100LA4	162
1.5	5072	1.8	920	52000	—	—	—	—	VF/VF 130/250_920	P100	BN100LA4	168
1.8	4887	1.3	800	34500	—	—	—	—	VF/VF 130/210_800	P100	BN100LA4	162
1.8	5007	1.8	800	52000	—	—	—	—	VF/VF 130/250_800	P100	BN100LA4	168
2.4	4023	1.0	600	19500	—	—	—	—	W/VF 86/185_600	P100	BN100LA4	157
2.4	3844	1.6	600	34500	—	—	—	—	VF/VF 130/210_600	P100	BN100LA4	162
2.4	3934	2.3	600	52000	—	—	—	—	VF/VF 130/250_600	P100	BN100LA4	168
3.1	3286	1.1	300	34500	—	—	—	—	VFR 210_300	P112	BN112M6	160







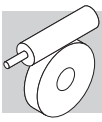

2.2 kW







n ₂ min-1	M ₂ Nm	S	i	R _{n2} N						IEC 		
3.1	3487	1.5	300	52000	—	—	—	VFR 250_300	P112	BN112M6	166	
3.5	2861	1.5	400	19500	—	—	—	W/VF 86/185_400	P100	BN100LA4	157	
3.5	2980	2.1	400	34500	—	—	—	VF/VF 130/210_400	P100	BN100LA4	162	
3.5	2921	3.1	400	52000	—	—	—	VF/VF 130/250_400	P100	BN100LA4	168	
3.9	2897	1.0	240	19500	—	—	—	VFR 185_240	P112	BN112M6	154	
3.9	2897	1.5	240	34500	—	—	—	VFR 210_240	P112	BN112M6	160	
3.9	3004	1.9	240	52000	—	—	—	VFR 250_240	P112	BN112M6	166	
4.7	2459	0.9	300	19500	—	—	—	VFR 185_300	P100	BN100LA4	154	
4.7	2459	1.4	300	34500	—	—	—	VFR 210_300	P100	BN100LA4	160	
4.7	2548	2.0	300	52000	—	—	—	VFR 250_300	P100	BN100LA4	166	
5.0	2170	1.9	280	19500	—	—	—	W/VF 86/185_280	P100	BN100LA4	157	
5.0	2170	2.9	280	34500	—	—	—	VF/VF 130/210_280	P100	BN100LA4	162	
5.6	2291	0.9	168	16000	—	—	—	VFR 150_168	P112	BN112M6	148	
5.9	2110	1.3	240	19500	—	—	—	VFR 185_240	P100	BN100LA4	154	
5.9	2110	1.8	240	34500	—	—	—	VFR 210_240	P100	BN100LA4	160	
5.9	2181	2.5	240	52000	—	—	—	VFR 250_240	P100	BN100LA4	166	
7.3	1774	1.0	192	16000	—	—	—	VFR 150_192	P100	BN100LA4	148	
7.8	1690	0.9	120	13800	—	—	—	VFR 130_120	P112	BN112M6	142	
7.8	1743	1.7	180	19500	—	—	—	VFR 185_180	P100	BN100LA4	154	
7.8	1717	2.5	180	34500	—	—	—	VFR 210_180	P100	BN100LA4	160	
7.8	1797	3.5	180	52000	—	—	—	VFR 250_180	P100	BN100LA4	166	
8.4	1627	1.1	168	16000	—	—	—	VFR 150_168	P100	BN100LA4	148	
9.4	1386	1.4	100	19000	—	—	—	VF 185_100	P112	BN112M6	152	
9.4	1498	2.2	150	19500	—	—	—	VFR 185_150	P100	BN100LA4	154	
9.4	1498	3.0	150	34500	—	—	—	VFR 210_150	P100	BN100LA4	160	
10.2	1378	1.0	138	13800	—	—	—	VFR 130_138	P100	BN100LA4	142	
10.2	1398	1.4	138	16000	—	—	—	VFR 150_138	P100	BN100LA4	148	
10.4	1468	2.2	90	19500	—	—	—	VFR 185_90	P112	BN112M6	154	
10.4	1448	3.2	90	34500	—	—	—	VFR 210_90	P112	BN112M6	160	
11.8	1162	1.2	80	15500	—	—	—	VF 150_80	P112	BN112M6	146	
11.8	1198	1.2	120	13800	—	—	—	VFR 130_120	P100	BN100LA4	142	
11.8	1216	1.6	120	16000	—	—	—	VFR 150_120	P100	BN100LA4	148	
11.8	1180	2.0	80	19000	—	—	—	VF 185_80	P112	BN112M6	152	
11.8	1252	2.9	120	19500	—	—	—	VFR 185_120	P100	BN100LA4	154	
11.8	1252	4.0	120	34500	—	—	—	VFR 210_120	P100	BN100LA4	160	
13.6	1141	1.3	69	13800	—	—	—	VFR 130_69	P112	BN112M6	142	
13.6	1141	1.8	69	16000	—	—	—	VFR 150_69	P112	BN112M6	148	
14.1	969	1.2	100	14700	—	—	—	VF 150_100	P100	BN100LA4	146	
14.1	969	2.0	100	18000	—	—	—	VF 185_100	P100	BN100LA4	152	
14.7	973	1.1	64	13200	—	—	—	VF 130_64	P112	BN112M6	140	
15.7	952	1.6	90	13800	—	—	—	VFR 130_90	P100	BN100LA4	142	
15.7	966	2.0	90	16000	—	—	—	VFR 150_90	P100	BN100LA4	148	
15.7	952	2.7	60	19000	—	—	—	VF 185_60	P112	BN112M6	152	
15.7	1019	2.7	90	19500	—	—	—	VFR 185_90	P100	BN100LA4	154	
16.8	876	1.2	56	13200	—	—	—	VF 130_56	P112	BN112M6	140	
17.6	811	1.1	80	12600	—	—	—	VF 130_80	P100	BN100LA4	140	
17.6	823	1.5	80	14700	—	—	—	VF 150_80	P100	BN100LA4	146	
17.6	823	2.6	80	18000	—	—	—	VF 185_80	P100	BN100LA4	152	
20.4	751	1.5	46	13200	—	—	—	VF 130_46	P112	BN112M6	140	
20.4	781	1.7	69	13800	—	—	—	VFR 130_69	P100	BN100LA4	142	
20.4	761	2.3	46	15500	—	—	—	VF 150_46	P112	BN112M6	146	
20.4	792	2.3	69	16000	—	—	—	VFR 150_69	P100	BN100LA4	148	
20.9	774	1.1	45	8000	—	—	—	WR 110_45	P112	BN112M6	138	
22.0	677	1.4	64	12600	—	—	—	VF 130_64	P100	BN100LA4	140	
22.0	687	1.9	64	14700	—	—	—	VF 150_64	P100	BN100LA4	146	
23.3	660	1.1	40	8000	W 110_40	S3	M3LC6	136	W 110_40	P112	BN112M6	137
23.5	706	1.0	60	8000	—	—	—	—	WR 110_60	P100	BN100LA4	138
23.5	697	1.9	60	13800	—	—	—	—	VFR 130_60	P100	BN100LA4	142
23.5	706	2.7	60	16000	—	—	—	—	VFR 150_60	P100	BN100LA4	148
23.5	662	3.4	60	18000	—	—	—	—	VF 185_60	P100	BN100LA4	152
25.2	601	1.0	56	8000	W 110_56	S3	M3LA4	136	W 110_56	P100	BN100LA4	137
25.2	609	1.6	56	12600	—	—	—	—	VF 130_56	P100	BN100LA4	140
25.2	617	2.2	56	14200	—	—	—	—	VF 150_56	P100	BN100LA4	146
31	507	1.2	46	8000	W 110_46	S3	M3LA4	136	W 110_46	P100	BN100LA4	137
31	521	2.0	46	12600	—	—	—	—	VF 130_46	P100	BN100LA4	140



2.2 kW





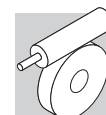

n ₂ min-1	M ₂ Nm	S	i	Rn ₂ N						IEC 	
31	528	2.9	46	14700	—	—	—	—	VF 150_46	P100 BN100LA4	146
31	536	1.3	45	8000	—	—	—	—	WR 110_45	P100 BN100LA4	138
31	550	3.1	45	16000	—	—	—	—	VFR 150_45	P100 BN100LA4	148
35	453	1.5	40	8000	W 110_40	S3 M3LA4	136	—	W 110_40	P100 BN100LA4	137
35	453	2.4	40	12600	—	—	—	—	VF 130_40	P100 BN100LA4	140
35	459	3.4	40	14700	—	—	—	—	VF 150_40	P100 BN100LA4	146
41	416	2.5	23	13200	—	—	—	—	VF 130_23	P112 BN112M6	140
47	340	1.1	30	7000	W 86_30	S3 M3LA4	132	—	W 86_30	P100 BN100LA4	133
47	344	2.0	30	8000	W 110_30	S3 M3LA4	136	—	W 110_30	P100 BN100LA4	137
47	353	3.0	30	12600	—	—	—	—	VF 130_30	P100 BN100LA4	140
61	281	1.1	23	6990	W 86_23	S3 M3LA4	132	—	W 86_23	P100 BN100LA4	133
61	284	1.9	23	8000	W 110_23	S3 M3LA4	136	—	W 110_23	P100 BN100LA4	137
61	284	3.1	23	12600	—	—	—	—	VF 130_23	P100 BN100LA4	140
71	247	1.0	20	3410	W 75_20	S3 M3LA4	128	—	W 75_20	P100 BN100LA4	129
71	250	1.3	20	6730	W 86_20	S3 M3LA4	132	—	W 86_20	P100 BN100LA4	133
71	250	2.3	20	8000	W 110_20	S3 M3LA4	136	—	W 110_20	P100 BN100LA4	137
94	190	1.3	15	3240	W 75_15	S3 M3LA4	128	—	W 75_15	P100 BN100LA4	129
94	190	1.7	15	6270	W 86_15	S3 M3LA4	132	—	W 86_15	P100 BN100LA4	133
94	188	3.2	15	8000	W 110_15	S3 M3LA4	136	—	W 110_15	P100 BN100LA4	137
133	139	1.5	7	2780	W 75_7	S3 M3LC6	128	—	W 75_7	P112 BN112M6	129
133	139	1.9	7	5540	W 86_7	S3 M3LC6	132	—	W 86_7	P112 BN112M6	133
141	131	1.8	10	2940	W 75_10	S3 M3LA4	128	—	W 75_10	P100 BN100LA4	129
141	131	2.2	10	5590	W 86_10	S3 M3LA4	132	—	W 86_10	P100 BN100LA4	133
187	99	2.3	15	2920	W 75_15	S3 M3SA2	128	—	W 75_15	P90 BN90L2	129
187	98	3.0	15	5290	W 86_15	S3 M3SA2	132	—	W 86_15	P90 BN90L2	133
192	94	1.3	15	1980	—	—	—	—	W 63_15	P90 BN90L2	125
201	94	2.0	7	2660	W 75_7	S3 M3LA4	128	—	W 75_7	P100 BN100LA4	129
201	93	2.7	7	5030	W 86_7	S3 M3LA4	132	—	W 86_7	P100 BN100LA4	133
240	76	1.6	12	1890	—	—	—	—	W 63_12	P90 BN90L2	125
281	67	3.0	10	2610	W 75_10	S3 M3SA2	128	—	W 75_10	P90 BN90L2	129
288	64	1.9	10	1820	—	—	—	—	W 63_10	P90 BN90L2	125
401	48	3.6	7	2350	W 75_7	S3 M3SA2	128	—	W 75_7	P90 BN90L2	129
411	46	2.3	7	1660	—	—	—	—	W 63_7	P90 BN90L2	125

3 kW

n ₂ min-1	M ₂ Nm	S	i	Rn ₂ N						IEC 	
0.88	10403	0.9	1600	52000	—	—	—	—	VF/VF 130/250_1600	P100 BN100LB4	168
1.0	9814	0.9	920	52000	—	—	—	—	VF/VF 130/250_920	P132 BN132S6	168
1.2	8534	1.1	1200	52000	—	—	—	—	VF/VF 130/250_1200	P100 BN100LB4	168
1.5	6917	0.9	920	34500	—	—	—	—	VF/VF 130/210_920	P100 BN100LB4	162
1.5	6917	1.3	920	52000	—	—	—	—	VF/VF 130/250_920	P100 BN100LB4	168
1.8	6665	0.9	800	34500	—	—	—	—	VF/VF 130/210_800	P100 BN100LB4	162
1.8	6827	1.3	800	52000	—	—	—	—	VF/VF 130/250_800	P100 BN100LB4	168
2.4	5242	1.2	600	34500	—	—	—	—	VF/VF 130/210_600	P100 BN100LB4	162
2.4	5364	1.7	600	52000	—	—	—	—	VF/VF 130/250_600	P100 BN100LB4	168
3.1	4755	1.1	300	52000	—	—	—	—	VFR 250_300	P132 BN132S6	166
3.5	3901	1.1	400	19500	—	—	—	—	W /VF 86/185_400	P100 BN100LB4	157
3.5	4064	1.6	400	34500	—	—	—	—	VF/VF 130/210_400	P100 BN100LB4	162
3.5	3983	2.3	400	52000	—	—	—	—	VF/VF 130/250_400	P100 BN100LB4	168
3.9	3950	1.1	240	34500	—	—	—	—	VFR 210_240	P132 BN132S6	160
3.9	4096	1.4	240	52000	—	—	—	—	VFR 250_240	P132 BN132S6	166
4.7	3353	1.0	300	34500	—	—	—	—	VFR 210_300	P100 BN100LB4	160
4.7	3475	1.4	300	52000	—	—	—	—	VFR 250_300	P100 BN100LB4	166
5.0	2958	1.4	280	19500	—	—	—	—	W /VF 86/185_280	P100 BN100LB4	157
5.0	2958	2.1	280	34500	—	—	—	—	VF/VF 130/210_280	P100 BN100LB4	162
5.0	3015	3.0	280	52000	—	—	—	—	VF/VF 130/250_280	P100 BN100LB4	168
5.9	2877	1.0	240	19500	—	—	—	—	VFR 185_240	P100 BN100LB4	154
5.9	2877	1.4	240	34500	—	—	—	—	VFR 210_240	P100 BN100LB4	160
5.9	2975	1.8	240	52000	—	—	—	—	VFR 250_240	P100 BN100LB4	166
7.8	2377	1.3	180	19500	—	—	—	—	VFR 185_180	P100 BN100LB4	154







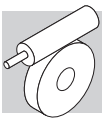

3 kW







n ₂ min-1	M ₂ Nm	S	i	R _{n2} N						IEC 		
7.8	2341	1.8	180	34500	—	—	—	VFR 210_180	P100	BN100LB4	160	
7.8	2450	2.6	180	52000	—	—	—	VFR 250_180	P100	BN100LB4	166	
9.4	1859	1.6	100	33000	—	—	—	VF 210_100	P132	BN132S6	158	
9.4	2042	1.6	150	19500	—	—	—	VFR 185_150	P100	BN100LB4	154	
9.4	2042	2.2	150	34500	—	—	—	VFR 210_150	P100	BN100LB4	160	
9.4	1920	2.5	100	50000	—	—	—	VF 250_100	P132	BN132S6	164	
9.4	2042	3.2	150	52000	—	—	—	VFR 250_150	P100	BN100LB4	166	
10.2	1907	1.0	138	16000	—	—	—	VFR 150_138	P100	BN100LB4	148	
11.8	1634	0.9	120	13800	—	—	—	VFR 130_120	P100	BN100LB4	142	
11.8	1658	1.2	120	16000	—	—	—	VFR 150_120	P100	BN100LB4	148	
11.8	1609	1.5	80	19000	—	—	—	VF 185_80	P132	BN132S6	152	
11.8	1585	2.1	80	33000	—	—	—	VF 210_80	P132	BN132S6	158	
11.8	1707	2.1	120	19500	—	—	—	VFR 185_120	P100	BN100LB4	154	
11.8	1707	2.9	120	34500	—	—	—	VFR 210_120	P100	BN100LB4	160	
11.8	1634	3.2	80	50000	—	—	—	VF 250_80	P132	BN132S6	164	
11.8	1731	4.0	120	52000	—	—	—	VFR 250_120	P100	BN100LB4	166	
14.1	1321	0.9	100	14700	—	—	—	VF 150_100	P100	BN100LB4	146	
14.1	1321	1.4	100	18000	—	—	—	VF 185_100	P100	BN100LB4	152	
15.7	1298	1.2	90	13800	—	—	—	VFR 130_90	P100	BN100LB4	142	
15.7	1317	1.5	90	16000	—	—	—	VFR 150_90	P100	BN100LB4	148	
15.7	1298	2.0	60	19000	—	—	—	VF 185_60	P132	BN132S6	152	
15.7	1390	2.0	90	19500	—	—	—	VFR 185_90	P100	BN100LB4	154	
15.7	1390	2.9	90	34500	—	—	—	VFR 210_90	P100	BN100LB4	160	
15.7	1280	2.9	60	33000	—	—	—	VF 210_60	P132	BN132S6	158	
17.6	1122	1.1	80	14700	—	—	—	VF 150_80	P100	BN100LB4	146	
17.6	1122	1.9	80	18000	—	—	—	VF 185_80	P100	BN100LB4	152	
20.4	1066	1.2	69	13800	—	—	—	VFR 130_69	P100	BN100LB4	142	
20.4	1080	1.7	69	16000	—	—	—	VFR 150_69	P100	BN100LB4	148	
22.0	923	1.0	64	12600	—	—	—	VF 130_64	P100	BN100LB4	140	
22.0	936	1.4	64	14700	—	—	—	VF 150_64	P100	BN100LB4	146	
23.5	951	1.4	60	13800	—	—	—	VFR 130_60	P100	BN100LB4	142	
23.5	963	2.0	60	16000	—	—	—	VFR 150_60	P100	BN100LB4	148	
23.5	902	2.5	60	18000	—	—	—	VF 185_60	P100	BN100LB4	152	
25.2	831	1.2	56	12600	—	—	—	VF 130_56	P100	BN100LB4	140	
25.2	842	1.6	56	14700	—	—	—	VF 150_56	P100	BN100LB4	146	
28.2	772	3.2	50	18000	—	—	—	VF 185_50	P100	BN100LB4	152	
31	710	1.5	46	12600	—	—	—	VF 130_46	P100	BN100LB4	140	
31	720	2.2	46	14700	—	—	—	VF 150_46	P100	BN100LB4	146	
31	731	1.0	45	8000	—	—	—	WR 110_45	P100	BN100LB4	138	
31	677	1.1	30	8000	—	—	—	W 110_30	P132	BN132S6	137	
31	750	2.3	45	16000	—	—	—	VFR 150_45	P100	BN100LB4	148	
31	741	3.2	30	19000	—	—	—	VF 185_30	P132	BN132S6	152	
35	618	1.1	40	8000	W 110_40	S3	M3LB4	136	W 110_40	P100	BN100LB4	137
35	618	1.8	40	12600	—	—	—	VF 130_40	P100	BN100LB4	140	
35	626	2.5	40	14700	—	—	—	VF 150_40	P100	BN100LB4	146	
41	568	1.0	23	8000	—	—	—	W 110_23	P132	BN132S6	137	
41	568	1.8	23	13200	—	—	—	VF 130_23	P132	BN132S6	140	
41	575	2.6	23	15500	—	—	—	VF 150_23	P132	BN132S6	146	
47	469	1.5	30	8000	W 110_30	S3	M3LB4	136	W 110_30	P100	BN100LB4	137
47	482	2.2	30	12600	—	—	—	VF 130_30	P100	BN100LB4	140	
47	488	2.8	30	14700	—	—	—	VF 150_30	P100	BN100LB4	146	
47	518	2.9	30	16000	—	—	—	VFR 150_30	P100	BN100LB4	148	
61	388	1.4	23	8000	W 110_23	S3	M3LB4	136	W 110_23	P100	BN100LB4	137
61	388	2.3	23	12600	—	—	—	VF 130_23	P100	BN100LB4	140	
61	388	3.3	23	14700	—	—	—	VF 150_23	P100	BN100LB4	146	
71	341	0.9	20	6240	W 86_20	S3	M3LB4	132	W 86_20	P100	BN100LB4	133
71	341	1.7	20	8000	W 110_20	S3	M3LB4	136	W 110_20	P100	BN100LB4	137
71	341	2.6	20	12600	—	—	—	VF 130_20	P100	BN100LB4	140	
94	259	1.0	15	2800	W 75_15	S3	M3LB4	128	W 75_15	P100	BN100LB4	129
94	259	1.3	15	5890	W 86_15	S3	M3LB4	132	W 86_15	P100	BN100LB4	133
94	256	2.3	15	8000	W 110_15	S3	M3LB4	136	W 110_15	P100	BN100LB4	137
94	262	3.5	15	11800	—	—	—	VF 130_15	P100	BN100LB4	140	
124	198	3.4	23	11000	—	—	—	VF 130_23	P100	BN100L2	140	
141	179	1.3	10	2600	W 75_10	S3	M3LB4	128	W 75_10	P100	BN100LB4	129
141	179	1.6	10	5300	W 86_10	S3	M3LB4	132	W 86_10	P100	BN100LB4	133



3 kW





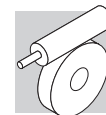

n ₂ min-1	M ₂ Nm	S	i	Rn ₂ N						IEC 		
141	177	3.1	10	8000	W 110_10	S3	M3LB4	136	W 110_10	P100	BN100LB4	137
191	132	1.7	15	2680	W 75_15	S3	M3LA2	128	W 75_15	P100	BN100L2	129
191	131	2.3	15	5070	W 86_15	S3	M3LA2	132	W 86_15	P100	BN100L2	133
201	128	1.5	7	2380	W 75_7	S3	M3LB4	128	W 75_7	P100	BN100LB4	129
201	127	2.0	7	4780	W 86_7	S3	M3LB4	132	W 86_7	P100	BN100LB4	133
286	90	2.3	10	2430	W 75_10	S3	M3LA2	128	W 75_10	P100	BN100L2	129
286	90	2.9	10	4510	W 86_10	S3	M3LA2	132	W 86_10	P100	BN100L2	133
409	64	2.7	7	2190	W 75_7	S3	M3LA2	128	W 75_7	P100	BN100L2	129
409	64	3.5	7	4040	W 86_7	S3	M3LA2	132	W 86_7	P100	BN100L2	133

4 kW







n ₂ min-1	M ₂ Nm	S	i	Rn ₂ N						IEC 	
1.5	9157	1.0	920	52000	—	—	—	VF/VF 130/250_920	P112	BN112M4	168
1.8	9039	1.0	800	52000	—	—	—	VF/VF 130/250_800	P112	BN112M4	168
2.4	6941	0.9	600	34500	—	—	—	VF/VF 130/210_600	P112	BN112M4	162
2.4	7102	1.3	600	52000	—	—	—	VF/VF 130/250_600	P112	BN112M4	168
3.6	5380	1.2	400	34500	—	—	—	VF/VF 130/210_400	P112	BN112M4	162
3.6	5273	1.7	400	52000	—	—	—	VF/VF 130/250_400	P112	BN112M4	168
4.0	5404	1.1	240	52000	—	—	—	VFR 250_240	P132	BN132MA6	166
4.7	4600	1.1	300	52000	—	—	—	VFR 250_300	P112	BN112M4	166
5.1	3917	1.1	280	19500	—	—	—	W /VF 86/185_280	P112	BN112M4	157
5.1	3917	1.6	280	34500	—	—	—	VF/VF 130/210_280	P112	BN112M4	162
5.1	3992	2.3	280	52000	—	—	—	VF/VF 130/250_280	P112	BN112M4	168
5.3	3908	1.3	180	34500	—	—	—	VFR 210_180	P132	BN132MA6	160
5.3	4487	1.5	180	52000	—	—	—	VFR 250_180	P132	BN132MA6	166
5.9	3809	1.0	240	34500	—	—	—	VFR 210_240	P112	BN112M4	160
5.9	3938	1.4	240	52000	—	—	—	VFR 250_240	P112	BN112M4	166
7.9	3147	1.0	180	19500	—	—	—	VFR 185_180	P112	BN112M4	154
7.9	3099	1.4	180	34500	—	—	—	VFR 210_180	P112	BN112M4	160
7.9	3244	1.9	180	52000	—	—	—	VFR 250_180	P112	BN112M4	166
9.5	2704	1.2	150	19500	—	—	—	VFR 185_150	P112	BN112M4	154
9.5	2704	1.7	150	34500	—	—	—	VFR 210_150	P112	BN112M4	160
9.5	2704	2.4	150	52000	—	—	—	VFR 250_150	P112	BN112M4	166
9.5	2453	1.2	100	33000	—	—	—	VF 210_100	P132	BN132MA6	158
9.5	2533	1.9	100	50000	—	—	—	VF 250_100	P132	BN132MA6	164
11.8	2195	0.9	120	16000	—	—	—	VFR 150_120	P112	BN112M4	148
11.8	2260	1.6	120	19500	—	—	—	VFR 185_120	P112	BN112M4	154
11.8	2260	2.2	120	34500	—	—	—	VFR 210_120	P112	BN112M4	160
11.8	2292	3.1	120	52000	—	—	—	VFR 250_120	P112	BN112M4	166
11.9	2123	1.1	80	19000	—	—	—	VF 185_80	P132	BN132MA6	152
11.9	2091	1.6	80	33000	—	—	—	VF 210_80	P132	BN132MA6	158
11.9	2155	2.4	80	50000	—	—	—	VF 250_80	P132	BN132MA6	164
14.2	1749	1.1	100	18000	—	—	—	VF 185_100	P112	BN112M4	152
15.8	1719	0.9	90	13800	—	—	—	VFR 130_90	P112	BN112M4	142
15.8	1743	1.1	90	16000	—	—	—	VFR 150_90	P112	BN112M4	148
15.8	1840	1.5	90	19500	—	—	—	VFR 185_90	P112	BN112M4	154
15.8	1840	2.2	90	34500	—	—	—	VFR 210_90	P112	BN112M4	160
15.8	1888	3.2	90	52000	—	—	—	VFR 250_90	P112	BN112M4	166
15.8	1713	1.5	60	19000	—	—	—	VF 185_60	P132	BN132MA6	152
15.8	1689	2.2	60	33000	—	—	—	VF 210_60	P132	BN132MA6	158
15.8	1737	3.2	60	50000	—	—	—	VF 250_60	P132	BN132MA6	164
17.8	1485	1.4	80	18000	—	—	—	VF 185_80	P112	BN112M4	152
20.6	1411	0.9	69	13800	—	—	—	VFR 130_69	P112	BN112M4	142
20.6	1429	1.3	69	16000	—	—	—	VFR 150_69	P112	BN112M4	148
20.7	1369	1.3	46	15500	—	—	—	VF 150_46	P132	BN132MA6	146
21.1	1448	3.4	45	34500	—	—	—	VFR 210_45	P132	BN132MA6	160
22.2	1240	1.1	64	14700	—	—	—	VF 150_64	P112	BN112M4	146
23.7	1259	1.1	60	13800	—	—	—	VFR 130_60	P112	BN112M4	142
23.7	1275	1.5	60	16000	—	—	—	VFR 150_60	P112	BN112M4	148
23.7	1194	1.9	60	18000	—	—	—	VF 185_60	P112	BN112M4	152



4 kW





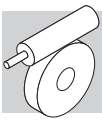

n ₂ min-1	M ₂ Nm	S	i	R _{n2} N						IEC 		
23.7	1307	2.5	60	19500	—	—	—	VFR 185_60	P112	BN112M4	154	
23.7	1291	3.6	60	34500	—	—	—	VFR 210_60	P112	BN112M4	160	
23.8	1174	1.0	40	13200	—	—	—	VF 130_40	P132	BN132MA6	140	
23.8	1206	3.6	40	33000	—	—	—	VF 210_40	P132	BN132MA6	158	
25.4	1100	0.9	56	12500	—	—	—	VF 130_56	P112	BN112M4	140	
25.4	1115	1.2	56	14700	—	—	—	VF 150_56	P112	BN112M4	146	
28.4	1022	2.4	50	18000	—	—	—	VF 185_50	P112	BN112M4	152	
31	940	1.1	46	12600	—	—	—	VF 130_46	P112	BN112M4	140	
31	953	1.6	46	14700	—	—	—	VF 150_46	P112	BN112M4	146	
32	993	1.7	45	16000	—	—	—	VFR 150_45	P112	BN112M4	148	
32	1017	2.8	45	19500	—	—	—	VFR 185_45	P112	BN112M4	154	
32	929	1.3	30	13200	—	—	—	VF 130_30	P132	BN132MA6	140	
32	977	2.5	30	19000	—	—	—	VF 185_30	P132	BN132MA6	152	
32	965	3.5	30	33000	—	—	—	VF 210_30	P132	BN132MA6	158	
36	818	1.3	40	12600	—	—	—	VF 130_40	P112	BN112M4	140	
36	829	1.9	40	14700	—	—	—	VF 150_40	P112	BN112M4	146	
36	769	0.9	80	12600	—	—	—	VF 130_80	P112	BN112M2	140	
41	749	1.4	23	13200	—	—	—	VF 130_23	P132	BN132MA6	140	
41	758	2.0	23	13200	—	—	—	VF 150_23	P132	BN132MA6	146	
45	641	1.1	64	12600	—	—	—	VF 130_64	P112	BN112M2	140	
46	635	1.1	30	8000	W 110_30	S3	M3LC4	136	W 110_30	P112	BN112M4	137
47	638	1.6	30	12600	—	—	—	VF 130_30	P112	BN112M4	140	
47	646	2.1	30	14700	—	—	—	VF 150_30	P112	BN112M4	146	
47	686	2.2	30	16000	—	—	—	VFR 150_30	P112	BN112M4	148	
60	525	1.0	23	8000	W 110_23	S3	M3LC4	136	W 110_23	P112	BN112M4	137
62	514	1.7	23	12600	—	—	—	VF 130_23	P112	BN112M4	140	
62	514	2.5	23	14700	—	—	—	VF 150_23	P112	BN112M4	146	
63	485	1.6	46	12600	—	—	—	VF 130_46	P112	BN112M2	140	
70	462	1.2	20	8000	W 110_20	S3	M3LC4	136	W 110_20	P112	BN112M4	137
71	452	2.0	20	12400	—	—	—	VF 130_20	P112	BN112M4	140	
93	350	0.9	15	5410	W 86_15	S3	M3LC4	132	W 86_15	P112	BN112M4	133
93	346	1.7	15	8000	W 110_15	S3	M3LC4	136	W 110_15	P112	BN112M4	137
95	347	2.7	15	11400	—	—	—	VF 130_15	P112	BN112M4	140	
95	350	3.4	10	12700	—	—	—	VF 150_10	P132	BN132MA6	146	
139	242	1.0	10	2160	W 75_10	S3	M3LC4	128	W 75_10	P112	BN112M4	129
139	242	1.2	10	4940	W 86_10	S3	M3LC4	132	W 86_10	P112	BN112M4	133
139	239	2.3	10	7840	W 110_10	S3	M3LC4	136	W 110_10	P112	BN112M4	137
142	237	3.3	10	10100	—	—	—	VF 130_10	P112	BN112M4	140	
191	176	1.3	15	2400	W 75_15	S3	M3LB2	128	W 75_15	P112	BN112M2	129
191	174	1.7	15	4820	W 86_15	S3	M3LB2	132	W 86_15	P112	BN112M2	133
191	174	3.1	15	7380	W 110_15	S3	M3LB2	136	W 110_15	P112	BN112M2	137
199	173	1.1	7	1900	W 75_7	S3	M3LC4	128	W 75_7	P112	BN112M4	129
199	171	1.5	7	4490	W 86_7	S3	M3LC4	132	W 86_7	P112	BN112M4	133
199	171	2.9	7	7040	W 110_7	S3	M3LC4	136	W 110_7	P112	BN112M4	137
287	120	1.7	10	2210	W 75_10	S3	M3LB2	128	W 75_10	P112	BN112M2	129
287	120	2.2	10	4320	W 86_10	S3	M3LB2	132	W 86_10	P112	BN112M2	133
410	85	2.0	7	2010	W 75_7	S3	M3LB2	128	W 75_7	P112	BN112M2	129
410	85	2.7	7	3890	W 86_7	S3	M3LB2	132	W 86_7	P112	BN112M2	133

5.5 kW

n ₂ min-1	M ₂ Nm	S	i	R _{n2} N						IEC 	
2.4	9630	0.9	600	52000	—	—	—	VF/VF 130/250_600	P132	BN132S4	168
3.4	7937	1.2	280	52000	—	—	—	VF/VF 130/250_280	P132	BN132MB6	168
3.6	7295	0.9	400	34500	—	—	—	VF/VF 130/210_400	P132	BN132S4	162
3.6	7149	1.3	400	52000	—	—	—	VF/VF 130/250_400	P132	BN132S4	168
5.1	5311	1.2	280	34500	—	—	—	VF/VF 130/210_280	P132	BN132S4	162
5.1	5413	1.7	280	52000	—	—	—	VF/VF 130/250_280	P132	BN132S4	168
5.3	6203	1.1	180	52000	—	—	—	VFR 250_180	P132	BN132MB6	166
6.3	5169	1.0	150	34500	—	—	—	VFR 210_150	P132	BN132MB6	160
6.3	5253	1.3	150	52000	—	—	—	VFR 250_150	P132	BN132MB6	166







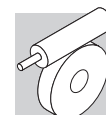

5.5 kW







n ₂ min-1	M ₂ Nm	S	i	R _{n2} N						IEC 	
8.0	4202	1.0	180	34500	—	—	—	VFR 210_180	P132	BN132S4	160
8.0	4399	1.4	180	52000	—	—	—	VFR 250_180	P132	BN132S4	166
9.5	3391	0.9	100	33000	—	—	—	VF 210_100	P132	BN132MB6	158
9.5	3502	1.4	100	50000	—	—	—	VF 250_100	P132	BN132MB6	164
9.6	3666	1.2	150	34500	—	—	—	VFR 210_150	P132	BN132S4	160
9.6	3666	1.8	150	52000	—	—	—	VFR 250_150	P132	BN132S4	166
11.8	2890	1.1	80	33000	—	—	—	VF 210_80	P132	BN132MB6	158
11.8	2979	1.7	80	50000	—	—	—	VF 250_80	P132	BN132MB6	164
12.0	3064	1.6	120	34500	—	—	—	VFR 210_120	P132	BN132S4	160
12.0	3108	2.3	120	52000	—	—	—	VFR 250_120	P132	BN132S4	166
14.4	2371	1.1	100	31500	—	—	—	VF 210_100	P132	BN132S4	158
14.4	2590	1.4	100	19500	—	—	—	VFR 185_100	P132	BN132S4	154
14.4	2480	1.5	100	47000	—	—	—	VF 250_100	P132	BN132S4	164
15.8	2368	1.1	60	19000	—	—	—	VF 185_60	P132	BN132MB6	152
15.8	2334	1.6	60	33000	—	—	—	VF 210_60	P132	BN132MB6	158
15.8	2401	2.3	60	50000	—	—	—	VF 250_60	P132	BN132MB6	164
16.0	2495	1.6	90	34500	—	—	—	VFR 210_90	P132	BN132S4	160
16.0	2561	2.3	90	52000	—	—	—	VFR 250_90	P132	BN132S4	166
18.0	2013	1.1	80	18000	—	—	—	VF 185_80	P132	BN132S4	152
18.0	2013	1.4	80	31500	—	—	—	VF 210_80	P132	BN132S4	158
18.0	2072	1.9	80	47000	—	—	—	VF 250_80	P132	BN132S4	164
19.2	2106	1.3	75	19500	—	—	—	VFR 185_75	P132	BN132S4	154
20.5	1892	0.9	46	15500	—	—	—	VF 150_46	P132	BN132MB6	146
21.0	2001	2.4	45	34500	—	—	—	VFR 210_45	P132	BN132MB6	160
21.0	2051	3.3	45	52000	—	—	—	VFR 250_45	P132	BN132MB6	166
23.6	1645	1.1	40	15500	—	—	—	VF 150_40	P132	BN132MB6	146
24.0	1620	1.4	60	18000	—	—	—	VF 185_60	P132	BN132S4	152
24.0	1598	1.9	60	31500	—	—	—	VF 210_60	P132	BN132S4	158
24.0	1751	2.7	60	34500	—	—	—	VFR 210_60	P132	BN132S4	160
24.0	1663	2.7	60	47000	—	—	—	VF 250_60	P132	BN132S4	164
24.0	1773	4.0	60	52000	—	—	—	VFR 250_60	P132	BN132S4	166
28.8	1430	1.3	50	15940	—	—	—	VFR 150_50	P132	BN132S4	148
28.8	1386	1.8	50	18000	—	—	—	VF 185_50	P132	BN132S4	152
28.8	1477	2.2	50	19500	—	—	—	VFR 185_50	P132	BN132S4	154
28.8	1386	2.4	50	31500	—	—	—	VF 210_50	P132	BN132S4	158
28.8	1386	3.2	50	47000	—	—	—	VF 250_50	P132	BN132S4	164
31	1292	1.2	46	14700	—	—	—	VF 150_46	P132	BN132S4	146
32	1284	1.0	30	13200	—	—	—	VF 130_30	P132	BN132MB6	140
32	1362	3.0	45	34500	—	—	—	VFR 210_45	P132	BN132S4	160
36	1109	1.0	40	12600	—	—	—	VF 130_40	P132	BN132S4	140
36	1123	1.4	40	14700	—	—	—	VF 150_40	P132	BN132S4	146
36	1138	2.3	40	18000	—	—	—	VF 185_40	P132	BN132S4	152
36	1138	3.1	40	31500	—	—	—	VF 210_40	P132	BN132S4	158
38	1101	1.5	37.5	15400	—	—	—	VFR 150_37.5	P132	BN132S4	148
38	1149	2.4	37.5	19500	—	—	—	VFR 185_37.5	P132	BN132S4	154
41	1035	1.0	23	13000	—	—	—	VF 130_23	P132	BN132MB6	140
41	1048	1.4	23	15300	—	—	—	VF 150_23	P132	BN132MB6	146
48	864	1.2	30	12600	—	—	—	VF 130_30	P132	BN132S4	140
48	875	1.6	30	14700	—	—	—	VF 150_30	P132	BN132S4	146
48	908	2.2	30	18000	—	—	—	VF 185_30	P132	BN132S4	152
48	908	3.4	30	31500	—	—	—	VF 210_30	P132	BN132S4	158
58	775	1.9	25	13400	—	—	—	VFR 150_25	P132	BN132S4	148
58	784	3.3	25	19500	—	—	—	VFR 185_25	P132	BN132S4	154
63	696	1.3	23	12100	—	—	—	VF 130_23	P132	BN132S4	140
63	696	1.8	23	14000	—	—	—	VF 150_23	P132	BN132S4	146
63	692	0.9	15	8000	—	—	—	W 110_15	P132	BN132MB6	137
72	613	0.9	20	8000	—	—	—	W 110_20	P132	BN132S4	137
72	613	1.5	20	11700	—	—	—	VF 130_20	P132	BN132S4	140
72	613	2.1	20	13500	—	—	—	VF 150_20	P132	BN132S4	146
96	460	1.3	15	8000	—	—	—	W 110_15	P132	BN132S4	137
96	471	2.0	15	12800	—	—	—	VF 130_15	P132	BN132S4	140
96	476	2.4	15	12400	—	—	—	VF 150_15	P132	BN132S4	146
126	359	1.9	23	10400	—	—	—	VF 130_23	P132	BN132SA2	140
126	359	2.7	23	11800	—	—	—	VF 150_23	P132	BN132SA2	146
144	317	1.7	10	7330	—	—	—	W 110_10	P132	BN132S4	137



5.5 kW





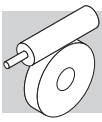

n ₂ min-1	M ₂ Nm	S	i	Rn ₂ N						IEC 	
144	321	2.5	10	9680	—	—	—	VF 130_10	P132	BN132S4	140
144	321	3.3	10	11000	—	—	—	VF 150_10	P132	BN132S4	146
193	237	2.3	15	7060	—	—	—	W 110_15	P132	BN132SA2	137
206	227	2.2	7	6600	—	—	—	W 110_7	P132	BN132S4	137
206	227	3.3	7	8650	—	—	—	VF 130_7	P132	BN132S4	140
289	162	3.0	10	6290	—	—	—	W 110_10	P132	BN132SA2	137
289	164	3.6	10	8110	—	—	—	VF 130_10	P132	BN132SA2	140
413	115	3.9	7	5640	—	—	—	W 110_7	P132	BN132SA2	137
413	116	4.8	7	7230	—	—	—	VF 130_7	P132	BN132SA2	140

7.5 kW







n ₂ min-1	M ₂ Nm	S	i	Rn ₂ N						IEC 	
3.6	9749	0.9	400	52000	—	—	—	VF/VF 130/250_400	P132	BN132MA4	168
5.1	7242	0.9	280	34500	—	—	—	VF/VF 130/210_280	P132	BN132MA4	162
5.1	7381	1.2	280	52000	—	—	—	VF/VF 130/250_280	P132	BN132MA4	168
6.4	7088	1.0	150	52000	—	—	—	VFR 250_150	P160	BN160M6	166
8.0	5940	1.0	120	34500	—	—	—	VFR 210_120	P160	BN160M6	160
8.0	5999	1.1	180	52000	—	—	—	VFR 250_180	P132	BN132MA4	166
9.6	4725	1.0	100	50000	—	—	—	VF 250_100	P160	BN160M6	164
9.6	4999	1.3	150	52000	—	—	—	VFR 250_150	P132	BN132MA4	166
10.6	4860	0.9	90	34500	—	—	—	VFR 210_90	P160	BN160M6	160
11.9	4020	1.3	80	50000	—	—	—	VF 250_80	P160	BN160M6	164
12.0	4178	1.2	120	34500	—	—	—	VFR 210_120	P132	BN132MA4	160
12.0	4238	1.7	120	52000	—	—	—	VFR 250_120	P132	BN132MA4	166
14.4	3532	1.0	100	19500	—	—	—	VFR 185_100	P132	BN132MA4	154
14.4	3382	1.1	100	47000	—	—	—	VF 250_100	P132	BN132MA4	164
15.9	3150	1.2	60	33000	—	—	—	VF 210_60	P160	BN160M6	158
16.0	3402	1.2	90	34500	—	—	—	VFR 210_90	P132	BN132MA4	160
16.0	3492	1.7	90	52000	—	—	—	VFR 250_90	P132	BN132MA4	166
18.0	2746	1.1	80	31500	—	—	—	VF 210_80	P132	BN132MA4	158
18.0	2825	1.4	80	47000	—	—	—	VF 250_80	P132	BN132MA4	164
19.2	2872	1.0	75	19500	—	—	—	VFR 185_75	P132	BN132MA4	154
21.2	2700	1.8	45	34500	—	—	—	VFR 210_45	P160	BN160M6	160
21.2	2768	2.5	45	52000	—	—	—	VFR 250_45	P160	BN160M6	166
24.0	2208	1.0	60	18000	—	—	—	VF 185_60	P132	BN132MA4	152
24.0	2179	1.4	60	31500	—	—	—	VF 210_60	P132	BN132MA4	158
24.0	2388	2.0	60	31500	—	—	—	VFR 210_60	P132	BN132MA4	160
24.0	2268	2.0	60	47000	—	—	—	VF 250_60	P132	BN132MA4	164
24.0	2417	2.9	60	52000	—	—	—	VFR 250_60	P132	BN132MA4	166
28.8	1950	1.0	50	14100	—	—	—	VFR 150_50	P132	BN132MA4	148
28.8	1890	1.3	50	18000	—	—	—	VF 185_50	P132	BN132MA4	152
28.8	2014	1.6	50	19500	—	—	—	VFR 185_50	P132	BN132MA4	154
28.8	1890	1.7	50	31500	—	—	—	VF 210_50	P132	BN132MA4	158
28.8	1890	2.4	50	47000	—	—	—	VF 250_50	P132	BN132MA4	164
31	1762	0.9	46	14700	—	—	—	VF 150_46	P132	BN132MA4	146
32	1858	2.2	45	34500	—	—	—	VFR 210_45	P132	BN132MA4	160
32	1880	3.4	45	48800	—	—	—	VFR 250_45	P132	BN132MA4	166
36	1532	1.0	40	14700	—	—	—	VF 150_40	P132	BN132MA4	146
36	1552	1.7	40	18000	—	—	—	VF 185_40	P132	BN132MA4	152
36	1552	2.3	40	31500	—	—	—	VF 210_40	P132	BN132MA4	158
36	1572	3.1	40	47000	—	—	—	VF 250_40	P132	BN132MA4	164
38	1501	1.1	37.5	13200	—	—	—	VFR 150_37.5	P132	BN132MA4	148
38	1567	1.8	37.5	18300	—	—	—	VFR 185_37.5	P132	BN132MA4	154
48	1179	0.9	30	11900	—	—	—	VF 130_30	P132	BN132MA4	140
48	1194	1.1	30	14200	—	—	—	VF 150_30	P132	BN132MA4	146
48	1239	1.6	30	18000	—	—	—	VF 185_30	P132	BN132MA4	152
48	1239	2.5	30	31500	—	—	—	VF 210_30	P132	BN132MA4	158
48	1283	3.0	30	33400	—	—	—	VFR 210_30	P132	BN132MA4	160
48	1253	3.2	30	4440	—	—	—	VF 250_30	P132	BN132MA4	164
58	1057	1.4	25	11000	—	—	—	VFR 150_25	P132	BN132MA4	148



7.5 kW





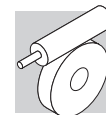

n ₂ min-1	M ₂ Nm	S	i	Rn ₂ N						IEC 	
58	1069	2.4	25	16700	—	—	—	VFR 185_25	P132	BN132MA4	154
63	950	0.9	23	11200	—	—	—	VF 130_23	P132	BN132MA4	140
63	950	1.3	23	13200	—	—	—	VF 150_23	P132	BN132MA4	146
64	968	2.3	15	16700	—	—	—	VF 185_15	P160	BN160M6	152
64	968	3.4	15	31500	—	—	—	VF 210_15	P160	BN160M6	158
72	836	1.1	20	10800	—	—	—	VF 130_20	P132	BN132MA4	140
72	836	1.6	20	12700	—	—	—	VF 150_20	P132	BN132MA4	146
96	627	1.0	15	7370	—	—	—	W 110_15	P132	BN132MA4	137
96	642	1.4	15	10200	—	—	—	VF 130_15	P132	BN132MA4	140
96	649	1.8	15	11700	—	—	—	VF 150_15	P132	BN132MA4	146
126	489	1.4	23	9900	—	—	—	VF 130_23	P132	BN132SB2	140
126	489	2.0	23	11400	—	—	—	VF 150_23	P132	BN132SB2	146
136	467	2.5	7	10200	—	—	—	VF 150_7	P160	BN160M6	146
144	433	1.3	10	6720	—	—	—	W 110_10	P132	BN132MA4	137
144	438	1.8	10	9150	—	—	—	VF 130_10	P132	BN132MA4	140
144	438	2.4	10	10500	—	—	—	VF 150_10	P132	BN132MA4	146
193	322	1.7	15	6660	—	—	—	W 110_15	P132	BN132SB2	137
206	310	1.6	7	6100	—	—	—	W 110_7	P132	BN132MA4	137
206	310	2.4	7	8210	—	—	—	VF 130_7	P132	BN132MA4	140
206	313	3.2	7	9400	—	—	—	VF 150_7	P132	BN132MA4	146
290	220	2.2	10	5980	—	—	—	W 110_10	P132	BN132SB2	137
290	222	2.7	10	7840	—	—	—	VF 130_10	P132	BN132SB2	140
414	156	2.9	7	5380	—	—	—	W 110_7	P132	BN132SB2	137
414	157	3.5	7	7010	—	—	—	VF 130_7	P132	BN132SB2	140

9.2 kW







n ₂ min-1	M ₂ Nm	S	i	Rn ₂ N						IEC 	
5.1	9054	1.0	280	52000	—	—	—	VF/VF 130/250_280	P132	BN132MB4	168
9.6	6132	1.1	150	52000	—	—	—	VFR 250_150	P132	BN132MB4	166
12.0	5198	1.3	120	52000	—	—	—	VFR 250_120	P132	BN132MB4	166
14.4	4149	0.9	100	47000	—	—	—	VF 250_100	P132	BN132MB4	164
16.0	4173	1.0	90	34500	—	—	—	VFR 210_90	P132	BN132MB4	160
16.0	4283	1.4	90	52000	—	—	—	VFR 250_90	P132	BN132MB4	166
18.0	3368	0.9	80	31500	—	—	—	VF 210_80	P132	BN132MB4	158
18.0	3466	1.1	80	47000	—	—	—	VF 250_80	P132	BN132MB4	164
24.0	2672	1.1	60	31500	—	—	—	VF 210_60	P132	BN132MB4	158
24.0	2929	1.6	60	34500	—	—	—	VFR 210_60	P132	BN132MB4	160
24.0	2782	1.6	60	47000	—	—	—	VF 250_60	P132	BN132MB4	164
24.0	2965	2.4	60	51900	—	—	—	VFR 250_60	P132	BN132MB4	166
28.8	2319	1.1	50	18000	—	—	—	VF 185_50	P132	BN132MB4	152
28.8	2471	1.3	50	18600	—	—	—	VFR 185_50	P132	BN132MB4	154
28.8	2319	1.4	50	31500	—	—	—	VF 210_50	P132	BN132MB4	158
28.8	2319	1.9	50	47000	—	—	—	VF 250_50	P132	BN132MB4	164
32	2279	1.8	45	34500	—	—	—	VFR 210_45	P132	BN132MB4	160
32	2306	2.8	45	48000	—	—	—	VFR 250_45	P132	BN132MB4	166
36	1904	1.4	40	18000	—	—	—	VF 185_40	P132	BN132MB4	152
36	1904	1.8	40	31500	—	—	—	VF 210_40	P132	BN132MB4	158
36	1928	2.5	40	47000	—	—	—	VF 250_40	P132	BN132MB4	164
38	1884	0.9	37.5	11900	—	—	—	VFR 150_37.5	P132	BN132MB4	148
38	1922	1.5	37.5	17200	—	—	—	VFR 185_37.5	P132	BN132MB4	154
48	1464	0.9	30	11300	—	—	—	VF 150_30	P132	BN132MB4	146
48	1519	1.3	30	17900	—	—	—	VF 185_30	P132	BN132MB4	152
48	1519	2.0	30	31500	—	—	—	VF 210_30	P132	BN132MB4	158
48	1574	2.4	30	32600	—	—	—	VFR 210_30	P132	BN132MB4	160
48	1538	2.6	30	43900	—	—	—	VF 250_30	P132	BN132MB4	164
48	1574	3.8	30	42800	—	—	—	VFR 250_30	P132	BN132MB4	166
58	1297	1.2	25	11200	—	—	—	VFR 150_25	P132	BN132MB4	148
58	1312	2.0	25	15800	—	—	—	VFR 185_25	P132	BN132MB4	154
63	1165	1.1	23	12500	—	—	—	VF 150_23	P132	BN132MB4	146
72	1025	0.9	20	10100	—	—	—	VF 130_20	P132	BN132MB4	140



9.2 kW





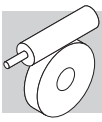

n ₂ min-1	M ₂ Nm	S	i	R _{n2} N						IEC 	
72	1025	1.3	20	12100	—	—	—	VF 150_20	P132	BN132MB4	146
72	1037	3.0	20	30400	—	—	—	VF 210_20	P132	BN132MB4	158
96	787	1.2	15	9560	—	—	—	VF 130_15	P132	BN132MB4	140
96	796	1.4	15	11200	—	—	—	VF 150_15	P132	BN132MB4	146
126	599	1.1	23	9510	—	—	—	VF 130_23	P132	BN132M2	140
126	599	1.6	23	11000	—	—	—	VF 150_23	P132	BN132M2	146
144	531	1.0	10	6210	—	—	—	W 110_10	P132	BN132MB4	137
144	537	1.5	10	8690	—	—	—	VF 130_10	P132	BN132MB4	140
144	537	2.0	10	16100	—	—	—	VF 150_10	P132	BN132MB4	146
193	395	1.4	15	6320	—	—	—	W 110_15	P132	BN132M2	137
206	380	1.3	7	5670	—	—	—	W 110_7	P132	BN132MB4	137
206	380	1.9	7	7820	—	—	—	VF 130_7	P132	BN132MB4	140
206	384	2.6	7	9030	—	—	—	VF 150_7	P132	BN132MB4	146
290	270	1.8	10	5720	—	—	—	W 110_10	P132	BN132M2	137
290	273	2.2	10	7620	—	—	—	VF 130_10	P132	BN132M2	140
290	273	2.9	10	8690	—	—	—	VF 150_10	P132	BN132M2	146
414	191	2.3	7	5170	—	—	—	W 110_7	P132	BN132M2	137
414	193	2.9	7	6820	—	—	—	VF 130_7	P132	BN132M2	140

11 kW







n ₂ min-1	M ₂ Nm	S	i	R _{n2} N						IEC 	
8.0	8798	0.9	120	52000	—	—	—	VFR 250_120	P160	BN160L6	166
10.7	7288	0.9	90	52000	—	—	—	VFR 250_90	P160	BN160L6	166
12.0	5865	0.9	80	50000	—	—	—	VF 250_80	P160	BN160L6	164
12.0	6215	1.1	120	52000	—	—	—	VFR 250_120	P160	BN160MR4	166
16.0	5056	1.1	60	34500	—	—	—	VFR 210_60	P160	BN160L6	160
16.0	5121	1.2	90	52000	—	—	—	VFR 250_90	P160	BN160MR4	166
16.0	4727	1.2	60	50000	—	—	—	VF 250_60	P160	BN160L6	164
18.0	4144	0.9	80	47000	—	—	—	VF 250_80	P160	BN160MR4	164
19.2	3939	1.0	50	33000	—	—	—	VF 210_50	P160	BN160L6	158
21.3	3939	1.2	45	34500	—	—	—	VFR 210_45	P160	BN160L6	160
21.3	4038	1.7	45	51300	—	—	—	VFR 250_45	P160	BN160L6	166
24.0	3327	0.9	40	18000	—	—	—	VF 185_40	P160	BN160L6	152
24.0	3195	0.9	60	31500	—	—	—	VF 210_60	P160	BN160MR4	158
24.0	3283	1.3	40	33000	—	—	—	VF 210_40	P160	BN160L6	158
24.0	3502	1.3	60	34500	—	—	—	VFR 210_60	P160	BN160MR4	160
24.0	3327	1.4	60	47000	—	—	—	VF 250_60	P160	BN160MR4	164
24.0	3327	2.0	40	50000	—	—	—	VF 250_40	P160	BN160L6	164
24.0	3545	2.0	60	50900	—	—	—	VFR 250_60	P160	BN160MR4	166
28.8	2772	1.2	50	31500	—	—	—	VF 210_50	P160	BN160MR4	158
28.8	2772	1.6	50	47000	—	—	—	VF 250_50	P160	BN160MR4	164
32	2659	0.9	30	18100	—	—	—	VF 185_30	P160	BN160L6	152
32	2725	1.5	45	34500	—	—	—	VFR 210_45	P160	BN160MR4	160
32	2758	2.3	45	47100	—	—	—	VFR 250_45	P160	BN160MR4	166
36	2276	1.2	40	18500	—	—	—	VF 185_40	P160	BN160MR4	152
36	2276	1.5	40	31500	—	—	—	VF 210_40	P160	BN160MR4	158
36	2305	2.1	40	47000	—	—	—	VF 250_40	P160	BN160MR4	164
48	1816	1.1	30	17200	—	—	—	VF 185_30	P160	BN160MR4	152
48	1816	1.7	30	31500	—	—	—	VF 210_30	P160	BN160MR4	158
48	1882	2.0	30	31800	—	—	—	VFR 210_30	P160	BN160MR4	160
48	1838	2.2	30	43400	—	—	—	VF 250_30	P160	BN160MR4	164
48	1882	3.2	30	42100	—	—	—	VFR 250_30	P160	BN160MR4	166
48	1860	3.2	20	43100	—	—	—	VF 250_20	P160	BN160L6	164
64	1395	1.0	15	10900	—	—	—	VF 150_15	P160	BN160L6	146
64	1412	1.6	15	15300	—	—	—	VF 185_15	P160	BN160L6	152
64	1412	2.3	15	30500	—	—	—	VF 210_15	P160	BN160L6	158
72	1226	1.1	20	11400	—	—	—	VF 150_20	P160	BN160MR4	146
72	1240	1.8	20	15600	—	—	—	VF 185_20	P160	BN160MR4	152
72	1240	2.5	20	30000	—	—	—	VF 210_20	P160	BN160MR4	158
96	952	1.2	15	10600	—	—	—	VF 150_15	P160	BN160MR4	146









11 kW

n ₂ min-1	M ₂ Nm	S	i	R _{n2} N						IEC 	
96	963	1.9	15	14200	—	—	—	VF 185_15	P160	BN160MR4	152
96	963	3.0	15	27700	—	—	—	VF 210_15	P160	BN160MR4	158
144	642	1.6	10	9670	—	—	—	VF 150_10	P160	BN160MR4	146
146	635	2.7	20	13300	—	—	—	VF 185_20	P160	BN160MR2	152
194	482	2.9	15	12200	—	—	—	VF 185_15	P160	BN160MR2	152
206	460	2.2	7	8660	—	—	—	VF 150_7	P160	BN160MR4	146
291	325	2.4	10	8440	—	—	—	VF 150_10	P160	BN160MR2	146
416	230	3.3	7	7530	—	—	—	VF 150_7	P160	BN160MR2	146

15 kW





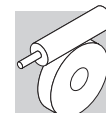

n ₂ min-1	M ₂ Nm	S	i	R _{n2} N						IEC 	
16.2	6380	0.9	60	50000	—	—	—	VF 250_60	P180	BN180L6	164
19.4	5390	1.2	50	50000	—	—	—	VF 250_50	P180	BN180L6	164
24.3	4430	1.0	40	33000	—	—	—	VF 210_40	P180	BN180L6	158
24.3	4489	1.4	40	50000	—	—	—	VF 250_40	P180	BN180L6	164
24.3	4474	1.0	60	47000	—	—	—	VF 250_60	P160	BN160L4	164
24.3	4768	1.5	60	48700	—	—	—	VFR 250_60	P160	BN160L4	166
29.2	3728	0.9	50	31500	—	—	—	VF 210_50	P160	BN160L4	158
29.2	3728	1.2	50	47000	—	—	—	VF 250_50	P160	BN160L4	164
32	3665	1.1	45	33200	—	—	—	VFR 210_45	P160	BN160L4	160
32	3709	1.7	45	45200	—	—	—	VFR 250_45	P160	BN160L4	166
37	3061	0.9	40	16600	—	—	—	VF 185_40	P160	BN160L4	152
37	3061	1.1	40	31500	—	—	—	VF 210_40	P160	BN160L4	158
37	3100	1.5	40	45900	—	—	—	VF 250_40	P160	BN160L4	164
49	2481	1.1	20	14800	—	—	—	VF 185_20	P180	BN180L6	152
49	2443	1.2	30	31500	—	—	—	VF 210_30	P160	BN160L4	158
49	2531	1.5	30	30000	—	—	—	VFR 210_30	P160	BN160L4	160
49	2473	1.6	30	42400	—	—	—	VF 250_30	P160	BN160L4	164
49	2531	2.4	30	40600	—	—	—	VFR 250_30	P160	BN160L4	166
65	1905	1.2	15	13600	—	—	—	VF 185_15	P180	BN180L6	152
65	1905	1.7	15	29300	—	—	—	VF 210_15	P180	BN180L6	158
65	1927	2.8	15	38700	—	—	—	VF 250_15	P180	BN180L6	164
73	1668	1.4	20	14300	—	—	—	VF 185_20	P160	BN160L4	152
73	1668	1.9	20	29100	—	—	—	VF 210_20	P160	BN160L4	158
73	1688	2.6	20	38100	—	—	—	VF 250_20	P160	BN160L4	164
97	1280	0.9	15	9360	—	—	—	VF 150_15	P160	BN160L4	146
97	1295	1.4	15	13200	—	—	—	VF 185_15	P160	BN160L4	152
97	1295	2.2	15	27000	—	—	—	VF 210_15	P160	BN160L4	158
97	1295	3.1	15	35100	—	—	—	VF 250_15	P160	BN160L4	164
139	920	2.2	7	11400	—	—	—	VF 185_7	P180	BN180L6	152
146	863	1.2	10	8720	—	—	—	VF 150_10	P160	BN160L4	146
146	873	3.0	10	24000	—	—	—	VF 210_10	P160	BN160L4	158
147	860	2.0	20	12700	—	—	—	VF 185_20	P160	BN160MB2	152
195	653	2.1	15	11600	—	—	—	VF 185_15	P160	BN160MB2	152
195	653	3.3	15	22700	—	—	—	VF 210_15	P160	BN160MB2	158
209	618	1.6	7	7840	—	—	—	VF 150_7	P160	BN160L4	146
293	440	1.8	10	7960	—	—	—	VF 150_10	P160	BN160MB2	146
419	311	2.4	7	7120	—	—	—	VF 150_7	P160	BN160MB2	146

18.5 kW







n ₂ min-1	M ₂ Nm	S	i	R _{n2} N						IEC 	
19.2	6717	0.9	50	50000	—	—	—	VF 250_50	P200	BN200LA6	164
24.0	5595	1.2	40	48700	—	—	—	VF 250_40	P200	BN200LA6	164
29.2	4598	1.0	50	47000	—	—	—	VF 250_50	P180	BN180M4	164
32	4472	1.2	30	45200	—	—	—	VF 250_30	P200	BN200LA6	164









18.5 kW

n ₂ min-1	M ₂ Nm	S	i	Rn ₂ N						IEC 	
37	3776	0.9	40	31500	—	—	—	VF 210_40	P180	BN180M4	158
37	3824	1.3	40	44900	—	—	—	VF 250_40	P180	BN180M4	164
49	3013	1.0	30	31200	—	—	—	VF 210_30	P180	BN180M4	158
49	3049	1.3	30	41500	—	—	—	VF 250_30	P180	BN180M4	164
64	2374	1.4	15	28300	—	—	—	VF 210_15	P200	BN200LA6	158
64	2402	2.2	15	37800	—	—	—	VF 250_15	P200	BN200LA6	164
73	2057	1.1	20	13200	—	—	—	VF 185_20	P180	BN180M4	152
73	2057	1.5	20	28300	—	—	—	VF 210_20	P180	BN180M4	158
73	2081	2.1	20	37400	—	—	—	VF 250_20	P180	BN180M4	164
97	1597	1.2	15	12200	—	—	—	VF 185_15	P180	BN180M4	152
97	1597	1.8	15	26200	—	—	—	VF 210_15	P180	BN180M4	158
97	1597	2.5	15	34500	—	—	—	VF 250_15	P180	BN180M4	164
146	1077	1.7	10	11400	—	—	—	VF 185_10	P180	BN180M4	152
146	1077	2.5	10	23400	—	—	—	VF 210_10	P180	BN180M4	158
146	1089	3.4	10	37800	—	—	—	VF 250_10	P180	BN180M4	164
195	805	1.1	15	8260	—	—	—	VF 150_15	P160	BN160L2	146
209	762	2.3	7	10100	—	—	—	VF 185_7	P180	BN180M4	152
209	762	3.0	7	21200	—	—	—	VF 210_7	P180	BN180M4	158
293	543	1.5	10	7550	—	—	—	VF 150_10	P160	BN160L2	146
419	384	2.0	7	6760	—	—	—	VF 150_7	P160	BN160L2	146

22 kW





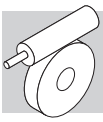

n ₂ min-1	M ₂ Nm	S	i	Rn ₂ N						IEC 	
22.5	7097	0.9	40	47100	—	—	—	VF 250_40	P200	BN200L6	164
30	5673	1.0	30	43900	—	—	—	VF 250_30	P200	BN200L6	164
37	4532	1.1	40	43900	—	—	—	VF 250_40	P180	BN180L4	164
49	3571	0.9	30	30200	—	—	—	VF 210_30	P180	BN180L4	158
49	3614	1.1	30	44700	—	—	—	VF 250_30	P180	BN180L4	164
60	3011	1.1	15	27200	—	—	—	VF 210_15	P200	BN200L6	158
60	3046	1.7	15	36900	—	—	—	VF 250_15	P200	BN200L6	164
73	2438	0.9	20	12200	—	—	—	VF 185_20	P180	BN180L4	152
73	2438	1.3	20	27500	—	—	—	VF 210_20	P180	BN180L4	158
73	2467	1.8	20	36700	—	—	—	VF 250_20	P180	BN180L4	164
98	1893	1.0	15	11300	—	—	—	VF 185_15	P180	BN180L4	152
98	1893	1.5	15	25500	—	—	—	VF 210_15	P180	BN180L4	158
98	1893	2.1	15	33900	—	—	—	VF 250_15	P180	BN180L4	164
147	1276	1.4	10	10700	—	—	—	VF 185_10	P180	BN180L4	152
147	1276	2.1	10	22900	—	—	—	VF 210_10	P180	BN180L4	158
147	1291	2.9	10	30300	—	—	—	VF 250_10	P180	BN180L4	164
209	904	1.9	7	9510	—	—	—	VF 185_7	P180	BN180L4	152
209	904	2.5	7	20800	—	—	—	VF 210_7	P180	BN180L4	158
209	914	3.5	7	27500	—	—	—	VF 250_7	P180	BN180L4	164
293	645	2.1	10	9730	—	—	—	VF 185_10	P180	BN180M2	152
293	645	3.1	10	23900	—	—	—	VF 210_10	P180	BN180M2	158
419	457	2.9	7	8660	—	—	—	VF 185_7	P180	BN180M2	152

30 kW







n ₂ min-1	M ₂ Nm	S	i	Rn ₂ N						IEC 	
45	5412	1.1	20	37600	—	—	—	VF 250_20	P225	BN225M6	164
60	4154	1.3	15	35000	—	—	—	VF 250_15	P225	BN225M6	164
74	3313	0.9	20	25800	—	—	—	VF 210_20	P200	BN200L4	158
74	3352	1.3	20	35200	—	—	—	VF 250_20	P200	BN200L4	164
98	2573	1.1	15	24000	—	—	—	VF 210_15	P200	BN200L4	158
98	2573	1.6	15	32600	—	—	—	VF 250_15	P200	BN200L4	164
147	1735	1.5	10	21600	—	—	—	VF 210_10	P200	BN200L4	158









30 kW

n ₂ min-1	M ₂ Nm	S	i	R _{n2} N						IEC 	
147	1754	2.1	10	29200	—	—	—	VF 250_10	P200	BN200L4	164
210	1228	1.9	7	19700	—	—	—	VF 210_7	P200	BN200L4	158
210	1242	2.6	7	26600	—	—	—	VF 250_7	P200	BN200L4	164
295	874	2.3	10	19000	—	—	—	VF 210_10	P200	BN200LA2	158
421	619	2.8	7	17200	—	—	—	VF 210_7	P200	BN200LA2	158

37 kW

n ₂ min-1	M ₂ Nm	S	i	R _{n2} N						IEC 	
74	4107	1.1	20	22800	—	—	—	VF 250_20	P225	BN225S4	164
99	3152	0.9	15	22600	—	—	—	VF 210_15	P225	BN225S4	158
99	3152	1.3	15	31400	—	—	—	VF 250_15	P225	BN225S4	164
148	2125	1.2	10	20500	—	—	—	VF 210_10	P225	BN225S4	158
148	2149	1.7	10	28300	—	—	—	VF 250_10	P225	BN225S4	164
211	1504	1.5	7	18800	—	—	—	VF 210_7	P225	BN225S4	158
211	1521	2.1	7	25800	—	—	—	VF 250_7	P225	BN225S4	164
296	1074	1.9	10	18400	—	—	—	VF 210_10	P200	BN200L2	158
296	1086	2.6	10	24500	—	—	—	VF 250_10	P200	BN200L2	164
423	760	2.3	7	16800	—	—	—	VF 210_7	P200	BN200L2	158

45 kW

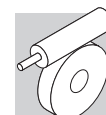

n ₂ min-1	M ₂ Nm	S	i	R _{n2} N						IEC 	
74	4994	0.9	20	32300	—	—	—	VF 250_20	P225	BN225M4	164
99	3833	1.0	15	30100	—	—	—	VF 250_15	P225	BN225M4	164
148	2584	1.0	10	19200	—	—	—	VF 210_10	P225	BN225M4	158
148	2613	1.4	10	27300	—	—	—	VF 250_10	P225	BN225M4	164
211	1829	1.3	7	17800	—	—	—	VF 210_7	P225	BN225M4	158
211	1850	1.7	7	25000	—	—	—	VF 250_7	P225	BN225M4	164
296	1307	1.5	10	17800	—	—	—	VF 210_10	P200	BN225M2	158
296	1321	2.1	10	24000	—	—	—	VF 250_10	P200	BN225M2	164
423	925	1.9	7	16200	—	—	—	VF 210_7	P200	BN225M2	158
423	935	2.6	7	21800	—	—	—	VF 250_7	P200	BN225M2	164



22 DONNEES TECHNIQUES REDUCTEURS



VF 27

13 Nm

		i	η_s %	n_2	M_{n2}	P_{n1}	R_{n1}	R_{n2}	η_d	n_2	M_{n2}	P_{n1}	R_{n1}	R_{n2}	η_d	
				min ⁻¹	Nm	kW	N	N	%	min ⁻¹	Nm	kW	N	N	%	
				$n_1 = 2800 \text{ min}^{-1}$					$n_1 = 1400 \text{ min}^{-1}$							
VF 27	VF 27_7	7	67	400	7	0.34	—	330	86	200	9	0.23	35	410	83	169
	VF 27_10	10	62	280	7	0.24	—	400	84	140	9	0.16	30	500	80	
	VF 27_15	15	54	187	7	0.17	—	480	79	93	9	0.12	—	600	75	
	VF 27_20	20	49	140	7	0.14	—	540	76	70	9	0.09	—	600	71	
	VF 27_30	30	38	93	7	0.10	—	600	69	47	9	0.07	—	600	62	
	VF 27_40	40	33	70	7	0.08	—	600	64	35	9	0.06	—	600	57	
	VF 27_60	60	26	47	7	0.06	—	600	56	23.3	9	0.04	—	600	49	
	VF 27_70	70	24	40	7	0.06	—	600	53	20.0	9	0.04	—	600	45	
					$n_1 = 900 \text{ min}^{-1}$					$n_1 = 500 \text{ min}^{-1}$						
	VF 27_7	7	67	129	10	0.17	90	480	81	71	11	0.11	90	600	79	169
	VF 27_10	10	62	90	11	0.13	20	570	78	50	12	0.08	90	600	76	
	VF 27_15	15	54	60	11	0.09	—	600	72	33	12	0.06	90	600	69	
	VF 27_20	20	49	45	11	0.08	—	600	68	25.0	12	0.05	90	600	65	
	VF 27_30	30	38	30.0	11	0.06	—	600	59	16.7	13	0.04	—	600	55	
VF 27_40	40	33	22.5	11	0.05	—	600	54	12.5	13	0.04	—	600	50		
VF 27_60	60	26	15.0	11	0.04	—	600	45	8.3	12	0.02	—	600	41		
VF 27_70	70	24	12.9	10	0.03	—	600	42	7.1	11	0.02	—	600	38		

VF 30

24 Nm

		i	η_s %	n_2	M_{n2}	P_{n1}	R_{n1}	R_{n2}	η_d	n_2	M_{n2}	P_{n1}	R_{n1}	R_{n2}	η_d	
				min ⁻¹	Nm	kW	N	N	%	min ⁻¹	Nm	kW	N	N	%	
				$n_1 = 2800 \text{ min}^{-1}$					$n_1 = 1400 \text{ min}^{-1}$							
VF 30	VF 30_7	7	69	400	12	0.58	120	510	87	200	16	0.41	140	630	84	169
	VF 30_10	10	64	280	12	0.41	70	620	85	140	16	0.30	80	770	81	
	VF 30_15	15	56	187	14	0.34	—	720	81	93	18	0.24	—	910	76	
	VF 30_20	20	51	140	14	0.26	—	820	78	70	18	0.19	—	1030	73	
	VF 30_30	30	41	93	15	0.21	—	960	71	47	20	0.15	—	1200	65	
	VF 30_40	40	36	70	14	0.16	—	1090	66	35	19	0.12	—	1360	60	
	VF 30_60	60	29	47	14	0.12	—	1270	59	23.3	19	0.09	—	1590	51	
	VF 30_70	70	26	40	11	0.08	—	1380	55	20.0	15	0.07	—	1600	48	
					$n_1 = 900 \text{ min}^{-1}$					$n_1 = 500 \text{ min}^{-1}$						
	VF 30_7	7	69	129	18	0.30	150	730	82	71	20	0.19	150	920	81	169
	VF 30_10	10	64	90	18	0.22	150	900	79	50	20	0.14	150	1120	77	
	VF 30_15	15	56	60	20	0.17	—	1060	74	33	22	0.11	150	1320	71	
	VF 30_20	20	51	45	20	0.14	—	1200	70	25.0	22	0.09	150	1490	67	
	VF 30_30	30	41	30	22	0.12	—	1400	61	16.7	24	0.07	—	1700	58	
VF 30_40	40	36	23	20	0.09	—	1590	56	12.5	22	0.06	—	1700	53		
VF 30_60	60	29	15	20	0.07	—	1650	48	8.3	22	0.05	—	1700	44		
VF 30_70	70	26	13	17	0.05	—	1700	45	7.0	19	0.04	—	1700	41		

(-) Consulter notre service technique en donnant les détails concernant la charge radiale (sens de rotation, indexage, position)

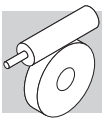

VF 44 - VF/VF 30/44

55 Nm

		i	η _s %	n ₁ = 2800 min ⁻¹						n ₁ = 1400 min ⁻¹						
				n ₂ min ⁻¹	M _{n2} Nm	P _{n1} kW	R _{n1} N	R _{n2} N	η _d %	n ₂ min ⁻¹	M _{n2} Nm	P _{n1} kW	R _{n1} N	R _{n2} N	η _d %	
				VF 44	VF 44_7	7	71	400	22	1.1	220	950	88	200	29	
VF 44_10	10	66	280	22	0.74	220	1150	87	140	29	0.51	220	1430	84		
VF 44_14	14	60	200	22	0.55	220	1340	84	100	29	0.37	220	1680	81		
VF 44_20	20	55	140	29	0.52	220	1490	81	70	39	0.37	220	1860	77		
VF 44_28	28	45	100	29	0.40	220	1710	76	50	39	0.29	220	2140	71		
VF 44_35	35	42	80	29	0.33	220	1870	73	40	39	0.25	220	2300	68		
VF 44_46	46	37	61	29	0.27	220	2080	69	30.0	39	0.19	220	2300	63		
VF 44_60	60	32	47	29	0.22	220	2290	65	23.3	39	0.16	220	2300	58		
VF 44_70	70	30	40	22	0.15	220	2300	62	20.0	29	0.11	220	2300	55		
VF 44_100	100	24	28	21	0.11	220	2300	55	14.0	28	0.09	220	2300	47		
				n ₁ = 900 min ⁻¹						n ₁ = 500 min ⁻¹						
	VF 44_7	7	71	129	39	0.63	220	1300	85	71	45	0.41	220	1610	83	169
	VF 44_10	10	66	90	39	0.45	220	1610	82	50	45	0.29	220	1980	80	
	VF 44_14	14	60	64	39	0.34	220	1890	78	36	50	0.25	220	2280	76	
	VF 44_20	20	55	45	45	0.29	220	2160	74	25.0	50	0.18	220	2500	72	
	VF 44_28	28	45	32	49	0.24	220	2300	67	17.9	55	0.16	220	2500	64	
	VF 44_35	35	42	25.7	49	0.20	220	2300	64	14.3	55	0.14	220	2500	60	
	VF 44_46	46	37	19.6	49	0.17	220	2300	59	10.9	50	0.10	220	2500	55	
	VF 44_60	60	32	15.0	45	0.13	200	2300	54	8.3	50	0.09	220	2500	50	
	VF 44_70	70	30	12.9	39	0.10	220	2300	51	7.1	45	0.07	220	2500	47	
	VF 44_100	100	24	9.0	30	0.06	220	2300	43	5.0	32	0.04	220	2500	39	

70 Nm

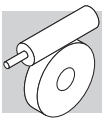

		i	η _s %	n ₁ = 1400 min ⁻¹						n ₁ = 900 min ⁻¹						
				n ₂ min ⁻¹	M _{n2} Nm	P _{n1} kW	R _{n1} N	R _{n2} N	η _d %	n ₂ min ⁻¹	M _{n2} Nm	P _{n1} kW	R _{n1} N	R _{n2} N	η _d %	
				VF/VF 30/44	VF/VF 30/44_245	245	29	5.7	60	0.09	140	2500	40	3.7	70	
	VF/VF 30/44_350	350	27	4.0	60	0.07	80	2500	36	2.6	70	0.05	150	2500	38	
	VF/VF 30/44_420	420	25	3.3	60	0.06	—	2500	35	2.1	70	0.04	—	2500	39	
	VF/VF 30/44_560	560	23	2.5	60	0.05	—	2500	31	1.6	70	0.04	—	2500	29	
	VF/VF 30/44_700	700	21	2.0	60	0.04	—	2500	31	1.3	70	0.03	—	2500	31	
	VF/VF 30/44_840	840	18	1.7	60	0.04	—	2500	26	1.1	70	0.03	—	2500	26	
	VF/VF 30/44_1120	1120	16	1.3	60	0.03	—	2500	26	0.80	70	0.02	—	2500	29	
	VF/VF 30/44_1680	1680	13	0.83	60	0.02	—	2500	26	0.54	70	0.02	—	2500	20	
	VF/VF 30/44_2100	2100	12	0.67	60	0.02	—	2500	21	0.43	70	0.02	—	2500	16	

(-) Consulter notre service technique en donnant les détails concernant la charge radiale (sens de rotation, indexage, position)



VF/VF 30/49

100 Nm

		i	η _s %	n ₁ = 1400 min ⁻¹						n ₁ = 900 min ⁻¹						
				n ₂ min ⁻¹	M _{n2} Nm	P _{n1} kW	R _{n1} N	R _{n2} N	η _d %	n ₂ min ⁻¹	M _{n2} Nm	P _{n1} kW	R _{n1} N	R _{n2} N	η _d %	
				VF/VF 30/49												
	VF/VF 30/49_240	240	32	5.8	95	0.13	80	3450	45	3.8	100	0.09	150	3450	44	172
	VF/VF 30/49_315	315	24	4.4	95	0.11	140	3450	40	2.9	100	0.07	150	3450	43	
	VF/VF 30/49_420	420	24	3.3	95	0.08	—	3450	41	2.1	100	0.06	—	3450	37	
	VF/VF 30/49_540	540	22	2.6	95	0.07	—	3450	37	1.7	100	0.05	—	3450	35	
	VF/VF 30/49_720	720	20	1.9	95	0.05	—	3450	39	1.3	100	0.04	—	3450	33	
	VF/VF 30/49_900	900	18	1.6	95	0.05	—	3450	31	1.0	100	0.04	—	3450	26	
	VF/VF 30/49_1120	1120	15	1.3	95	0.04	—	3450	31	0.80	100	0.03	—	3450	28	
	VF/VF 30/49_1440	1440	14	0.97	95	0.04	—	3450	24	0.63	100	0.03	—	3450	22	
	VF/VF 30/49_2160	2160	11	0.65	95	0.03	—	3450	21	0.42	100	0.02	—	3450	22	
	VF/VF 30/49_2700	2700	10	0.52	95	0.03	—	3450	17	0.33	100	0.02	—	3450	17	

(-) Consulter notre service technique en donnant les détails concernant la charge radiale (sens de rotation, indexage, position)

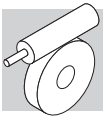

VF/W 30/63

230 Nm

		i	η _s %	n ₁ = 1400 min ⁻¹						n ₁ = 900 min ⁻¹						
				n ₂ min ⁻¹	M _{n2} Nm	P _{n1} kW	R _{n1} N	R _{n2} N	η _d %	n ₂ min ⁻¹	M _{n2} Nm	P _{n1} kW	R _{n1} N	R _{n2} N	η _d %	
VF/W 30/63	VF/W 30/63_240	240	33	5.8	210	0.27	80	5000	47	3.8	230	0.20	150	5000	45	172
	VF/W 30/63_315	315	26	4.4	210	0.23	140	5000	42	2.9	230	0.17	150	5000	41	
	VF/W 30/63_450	450	25	3.1	210	0.17	—	5000	41	2.0	230	0.11	—	5000	42	
	VF/W 30/63_570	570	22	2.5	210	0.14	—	5000	40	1.6	230	0.11	—	5000	36	
	VF/W 30/63_720	720	21	1.9	210	0.12	—	5000	37	1.3	230	0.09	—	5000	32	
	VF/W 30/63_900	900	18	1.6	210	0.11	—	5000	30	1.0	230	0.08	—	5000	29	
	VF/W 30/63_1200	1200	16	1.2	210	0.11	—	5000	24	0.75	230	0.07	—	5000	25	
	VF/W 30/63_1520	1520	14	0.92	210	0.08	—	5000	24	0.59	230	0.06	—	5000	23	
	VF/W 30/63_2280	2280	12	0.61	210	0.06	—	5000	21	0.39	230	0.04	—	5000	23	
	VF/W 30/63_2700	2700	11	0.52	210	0.05	—	5000	22	0.33	230	0.04	—	5000	19	

(-) Consulter notre service technique en donnant les détails concernant la charge radiale (sens de rotation, indexage, position)

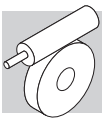

WR 75 - VF/W 44/75

370 Nm

	i	η_s %	$n_1 = 2800 \text{ min}^{-1}$						$n_1 = 1400 \text{ min}^{-1}$							
			n_2 min ⁻¹	M_{n2} Nm	P_{n1} kW	R_{n1} N	R_{n2} N	η_d %	n_2 min ⁻¹	M_{n2} Nm	P_{n1} kW	R_{n1} N	R_{n2} N	η_d %		
			WR 75_P90_B5													
WR 75_P90_B5	WR 75_15	15	66	187	220	4.8	—	1960	89	93	250	2.8	—	2640	86	171
	WR 75_22.5	22.5	59	124	240	3.6	—	2530	86	62	270	2.1	—	3380	83	
	WR 75_30	30	55	93	240	2.8	—	3020	84	47	270	1.6	—	3980	80	
	WR 75_37.5	37.5	51	75	240	2.3	—	3410	81	37	270	1.4	—	4480	77	
	WR 75_45	45	44	62	255	2.1	—	3660	79	31	290	1.3	—	4780	74	
	WR 75_60	60	39	47	240	1.6	—	4290	74	23.3	275	1.0	—	5540	68	
	WR 75_75	75	35	37	210	1.2	—	4860	70	18.7	235	0.73	—	6200	63	
			$n_1 = 900 \text{ min}^{-1}$						$n_1 = 500 \text{ min}^{-1}$							
WR 75_P90_B5	WR 75_15	15	66	60	275	2.1	—	3150	84	33	330	1.4	—	3850	82	171
	WR 75_22.5	22.5	59	40	295	1.5	—	4010	80	22.2	350	1.0	—	4920	78	
	WR 75_30	30	55	30	295	1.2	—	4710	77	16.7	330	0.77	—	5890	75	
	WR 75_37.5	37.5	51	24	295	1.0	—	5280	73	13.3	330	0.66	—	6200	70	
	WR 75_45	45	44	20	320	1.0	—	5610	69	11.1	370	0.64	—	6200	67	
	WR 75_60	60	39	15	305	0.76	—	6200	63	8.3	330	0.48	—	6200	60	
	WR 75_75	75	35	12	260	0.56	—	6200	58	6.7	310	0.39	—	6200	55	

400 Nm

	i	η_s %	$n_1 = 1400 \text{ min}^{-1}$						$n_1 = 900 \text{ min}^{-1}$							
			n_2 min ⁻¹	M_{n2} Nm	P_{n1} kW	R_{n1} N	R_{n2} N	η_d %	n_2 min ⁻¹	M_{n2} Nm	P_{n1} kW	R_{n1} N	R_{n2} N	η_d %		
			VF/W 44/75													
VF/W 44/75	VF/W 44/75_250	250	34	5.6	370	0.38	220	4560	57	3.6	400	0.29	220	4660	52	172
	VF/W 44/75_300	300	30	4.7	370	0.35	220	5160	51	3.0	400	0.27	220	5150	46	
	VF/W 44/75_400	400	26	3.5	370	0.29	220	6200	46	2.3	400	0.22	220	6200	42	
	VF/W 44/75_525	525	25	2.7	370	0.23	220	6200	44	1.7	400	0.18	220	6200	41	
	VF/W 44/75_700	700	24	2.0	370	0.18	220	6200	42	1.3	400	0.14	220	6200	39	
	VF/W 44/75_920	920	21	1.5	370	0.15	—	6200	40	1.0	400	0.11	60	6200	36	
	VF/W 44/75_1200	1200	18	1.2	370	0.12	—	6200	37	0.75	400	0.10	220	6200	31	
	VF/W 44/75_1500	1500	17	0.93	370	0.10	220	6200	37	0.60	400	0.09	220	6200	29	
	VF/W 44/75_2100	2100	14	0.67	370	0.09	220	6200	30	0.43	400	0.07	220	6200	24	
	VF/W 44/75_2800	2800	12	0.50	370	0.07	220	6200	26	0.32	400	0.06	220	6200	22	

(-) Consulter notre service technique en donnant les détails concernant la charge radiale (sens de rotation, indexage, position)

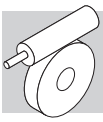

WR 86 - VF/W 44/86

500 Nm

			n₁ = 2800 min⁻¹							n₁ = 1400 min⁻¹										
			n₂	M_{n2}	P_{n1}	R_{n1}	R_{n2}	η_d	n₂	M_{n2}	P_{n1}	R_{n1}	R_{n2}	η_d						
			min ⁻¹	Nm	kW	N	N	%	min ⁻¹	Nm	kW	N	N	%						
WR 86_P90_B5		i	η_s													171				
	WR 86_15	15	66	187	275	6.1	—	4130	88	93	310	3.5	—	5410	86					
	WR 86_22.5	22.5	59	124	315	4.8	—	4920	86	62	355	2.8	—	6420	82					
	WR 86_30	30	59	93	305	3.5	—	5720	85	47	345	2.1	—	7000	81					
	WR 86_34.5	34.5	57	81	305	3.1	—	6110	84	41	345	1.8	—	7000	80					
	WR 86_45	45	44	62	350	3.0	—	6640	77	31	400	1.8	—	7000	73					
	WR 86_60	60	44	47	315	2.0	—	7000	77	23.3	355	1.2	—	7000	71					
	WR 86_69	69	42	41	325	1.8	—	7000	75	20.3	365	1.1	—	7000	69					
	WR 86_84	84	38	33	285	1.4	—	7000	72	16.7	325	0.86	—	7000	66					
					n₁ = 900 min⁻¹							n₁ = 500 min⁻¹								
	WR 86_15	15	66	60	345	2.6	—	6330	82	33	375	1.6	—	7000	81		171			
	WR 86_22.5	22.5	59	40	390	2.1	—	7000	78	22.2	450	1.4	—	7000	76					
	WR 86_30	30	59	30	380	1.6	—	7000	77	16.7	430	1.0	—	7000	75					
	WR 86_34.5	34.5	57	26.1	380	1.4	—	7000	75	14.5	390	0.8	—	7000	73					
WR 86_45	45	44	20.0	440	1.4	—	7000	67	11.1	500	0.9	—	7000	64						
WR 86_60	60	44	15.0	390	0.93	—	7000	66	8.3	440	0.61	—	7000	63						
WR 86_69	69	42	13.0	405	0.88	—	7000	63	7.2	430	0.53	—	7000	61						
WR 86_84	84	38	10.7	355	0.66	—	7000	60	6.0	390	0.43	—	7000	57						

550 Nm

			n₁ = 1400 min⁻¹							n₁ = 900 min⁻¹							
			n₂	M_{n2}	P_{n1}	R_{n1}	R_{n2}	η_d	n₂	M_{n2}	P_{n1}	R_{n1}	R_{n2}	η_d			
			min ⁻¹	Nm	kW	N	N	%	min ⁻¹	Nm	kW	N	N	%			
VF/W 44/86		i	η_s												172		
	VF/W 44/86_230	230	38	6.1	500	0.59	220	7000	54	3.9	550	0.43	220	7000		53	
	VF/W 44/86_300	300	30	4.7	500	0.54	220	7000	45	3.0	550	0.41	220	7000		42	
	VF/W 44/86_400	400	30	3.5	500	0.45	220	7000	41	2.3	550	0.32	220	7000		41	
	VF/W 44/86_525	525	25	2.7	500	0.33	220	7000	42	1.7	550	0.25	220	7000		39	
	VF/W 44/86_700	700	25	2.0	500	0.27	220	7000	39	1.3	550	0.20	220	7000		37	
	VF/W 44/86_920	920	22	1.5	500	0.20	220	7000	40	1.0	550	0.15	—	7000		37	
	VF/W 44/86_1380	1380	17	1.0	500	0.17	220	7000	32	0.65	550	0.13	—	7000		28	
	VF/W 44/86_1840	1840	17	0.76	500	0.13	220	7000	30	0.49	550	0.10	—	7000		28	
VF/W 44/86_2116	2116	16	0.66	500	0.12	220	7000	28	0.43	550	0.09	220	7000	28			
VF/W 44/86_2760	2760	14	0.51	500	0.11	—	7000	24	0.33	550	0.08	220	7000	24			

(-) Consulter notre service technique en donnant les détails concernant la charge radiale (sens de rotation, indexage, position)

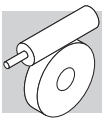

VF/W 49/110

1050 Nm



	i	η_s %	$n_1 = 1400 \text{ min}^{-1}$							$n_1 = 900 \text{ min}^{-1}$					
			n_2 min ⁻¹	M_{n2} Nm	P_{n1} kW	R_{n1} N	R_{n2} N	η_d %	n_2 min ⁻¹	M_{n2} Nm	P_{n1} kW	R_{n1} N	R_{n2} N	η_d %	
			VF/W 49/110												
VF/W 49/110_230	230	38	6.1	1000	1.2	400	8000	52	3.9	1050	0.84	400	8000	51	172
VF/W 49/110_300	300	29	4.7	1000	1.0	400	8000	48	3.0	1050	0.70	400	8000	47	
VF/W 49/110_400	400	30	3.5	1000	0.81	400	8000	45	2.3	1050	0.55	400	8000	45	
VF/W 49/110_540	540	25	2.6	1000	0.66	400	8000	41	1.7	1050	0.48	400	8000	38	
VF/W 49/110_720	720	24	1.9	1000	0.51	400	8000	40	1.3	1050	0.36	400	8000	38	
VF/W 49/110_1080	1080	18	1.3	1000	0.44	400	8000	31	0.83	1050	0.28	400	8000	30	
VF/W 49/110_1350	1350	16	1.0	1000	0.36	400	8000	30	0.67	1050	0.26	400	8000	28	
VF/W 49/110_1656	1656	17	0.85	1000	0.30	400	8000	30	0.54	1050	0.20	400	8000	30	
VF/W 49/110_2070	2070	15	0.68	1000	0.25	400	8000	28	0.43	1050	0.19	400	8000	25	
VF/W 49/110_2800	2800	13	0.50	1000	0.22	400	8000	24	0.32	1050	0.17	400	8000	21	

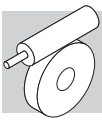

W/VF 63/130

1850 Nm



W/VF 63/130	i	η_s %	$n_1 = 1400 \text{ min}^{-1}$							$n_1 = 900 \text{ min}^{-1}$					172
			n_2 min ⁻¹	M_{n2} Nm	P_{n1} kW	R_{n1} N	R_{n2} N	η_d %	n_2 min ⁻¹	M_{n2} Nm	P_{n1} kW	R_{n1} N	R_{n2} N	η_d %	
W/VF 63/130_280	280	31	5.0	1800	1.9	480	13800	50	3.2	1850	1.3	480	13800	48	
W/VF 63/130_400	400	29	3.5	1800	1.5	480	13800	44	2.3	1850	0.99	480	13800	44	
W/VF 63/130_600	600	26	2.3	1800	1.1	480	13800	40	1.5	1850	0.73	480	13800	40	
W/VF 63/130_760	760	24	1.8	1800	0.89	480	13800	39	1.2	1850	0.62	480	13800	37	
W/VF 63/130_960	960	23	1.5	1800	0.74	480	13800	37	0.94	1850	0.52	480	13800	35	
W/VF 63/130_1200	1200	19	1.2	1800	0.65	—	13800	34	0.75	1850	0.45	—	13800	32	
W/VF 63/130_1520	1520	18	0.92	1800	0.55	—	13800	32	0.59	1850	0.38	—	13800	30	
W/VF 63/130_1800	1800	16	0.78	1800	0.52	—	13800	28	0.50	1850	0.37	—	13800	26	
W/VF 63/130_2560	2560	14	0.55	1800	0.45	—	13800	23	0.35	1850	0.32	—	13800	21	
W/VF 63/130_3200	3200	12	0.44	1800	0.49	—	13800	17	0.28	1850	0.34	480	13800	16	

(-) Consulter notre service technique en donnant les détails concernant la charge radiale (sens de rotation, indexage, position)

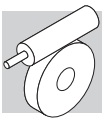

W/VF 86/150

2700 Nm



	<i>i</i>	η_s %	$n_1 = 1400 \text{ min}^{-1}$							$n_1 = 900 \text{ min}^{-1}$						
			n_2 min ⁻¹	M_{n2} Nm	P_{n1} kW	R_{n1} N	R_{n2} N	η_d %	n_2 min ⁻¹	M_{n2} Nm	P_{n1} kW	R_{n1} N	R_{n2} N	η_d %		
W/VF 86/150	W/VF 86/150_200	200	29	7.0	2600	3.0	850	16000	64	4.5	2700	2.1	850	16000	61	172
	W/VF 86/150_225	225	26	6.2	2600	2.7	850	16000	63	4.0	2700	1.9	850	16000	60	
	W/VF 86/150_300	300	26	4.7	2600	2.2	850	16000	58	3.0	2700	1.5	850	16000	57	
	W/VF 86/150_345	345	26	4.1	2600	1.9	850	16000	58	2.6	2700	1.3	850	16000	57	
	W/VF 86/150_460	460	26	3.0	2600	1.5	850	16000	55	2.0	2700	1.0	850	16000	55	
	W/VF 86/150_529	529	26	2.6	2600	1.3	850	16000	55	1.7	2700	0.93	850	16000	52	
	W/VF 86/150_690	690	26	2.0	2600	1.1	850	16000	50	1.3	2700	0.78	850	16000	47	
	W/VF 86/150_920	920	26	1.5	2600	0.92	850	16000	45	0.98	2700	0.64	850	16000	43	
	W/VF 86/150_1380	1380	19	1.0	2600	0.66	850	16000	42	0.65	2700	0.46	850	16000	40	
	W/VF 86/150_1840	1840	19	0.76	2600	0.55	850	16000	38	0.49	2700	0.38	850	16000	36	
	W/VF 86/150_2944	2944	16	0.48	2600	0.48	850	16000	27	0.31	2700	0.35	850	16000	25	

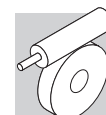

VF 185 - VFR 185

3600 Nm

			i	η_s %	$n_1 = 2800 \text{ min}^{-1}$					$n_1 = 1400 \text{ min}^{-1}$							
					n_2 min ⁻¹	M_{n2} Nm	P_{n1} kW	R_{n1} N	R_{n2} N	η_d %	n_2 min ⁻¹	M_{n2} Nm	P_{n1} kW	R_{n1} N		R_{n2} N	η_d %
VF 185	VF 185_7	7	72	400	1313	60	2800	4670	91	200	1750	41	2800	5570	90	169	
	VF 185_10	10	68	280	1365	44	2800	7390	90	140	1820	30	2800	8960	89		
	VF 185_15	15	66	187	1388	30	2800	9460	89	93	1850	21	2800	11600	88		
	VF 185_20	20	59	140	1703	28	2800	10500	88	70	2270	19.6	2800	12900	85		
	VF 185_30	30	54	93	1485	16.9	2800	13700	86	47	1980	11.8	2800	16900	83		
	VF 185_40	40	44	70	1973	17.6	—	14500	82	35	2630	12.4	—	17900	78		
	VF 185_50	50	41	56	1875	13.7	—	16300	80	28.0	2500	9.8	—	18000	76		
	VF 185_60	60	39	47	1703	10.7	2800	18000	78	23.3	2270	7.6	770	18000	74		
	VF 185_80	80	33	35	1590	7.8	2800	18000	75	17.5	2120	5.6	1140	18000	69		
	VF 185_100	100	30	28.0	1425	5.8	2800	18000	72	14.0	1900	4.3	2800	18000	65		
						$n_1 = 900 \text{ min}^{-1}$					$n_1 = 500 \text{ min}^{-1}$						
	VF 185_7	7	72	129	2000	30	2800	7120	89	71	2450	21	2800	8730	88	169	
	VF 185_10	10	68	90	2150	23	2800	10200	88	50	2600	16.0	2800	12500	86		
	VF 185_15	15	66	60	2250	16.4	2800	13100	86	33	2800	11.8	2800	15700	84		
	VF 185_20	20	59	45	2750	15.6	2800	14600	84	25.0	3300	10.9	2800	17900	81		
	VF 185_30	30	54	30.0	2400	9.4	2800	19000	81	16.7	2800	6.5	2800	19500	77		
	VF 185_40	40	44	22.5	3100	9.7	—	19000	76	12.5	3600	6.8	—	19500	71		
	VF 185_50	50	41	18.0	2900	7.6	—	19000	73	10.0	3300	5.2	—	19500	68		
VF 185_60	60	39	15.0	2600	5.8	700	19000	71	8.3	3000	4.2	2800	19500	66			
VF 185_80	80	33	11.3	2400	4.3	1770	19000	66	6.3	2800	3.2	2800	19500	60			
VF 185_100	100	30	9.0	2000	3.0	2800	19000	62	5.0	2300	2.1	2800	19500	56			

4200 Nm

			i	η_s %	$n_1 = 2800 \text{ min}^{-1}$					$n_1 = 1400 \text{ min}^{-1}$							
					n_2 min ⁻¹	M_{n2} Nm	P_{n1} kW	R_{n1} N	R_{n2} N	η_d %	n_2 min ⁻¹	M_{n2} Nm	P_{n1} kW	R_{n1} N		R_{n2} N	η_d %
VFR 185	VFR 185_90	90	53	31	2400	9.9	1700	19000	80	15.6	2800	6.0	1700	19500	76	171	
	VFR 185_120	120	43	23.3	3100	10.2	1700	19000	75	11.7	3600	6.3	1700	19500	70		
	VFR 185_150	150	40	18.7	2900	7.9	1700	19000	72	9.3	3300	4.8	1700	19500	67		
	VFR 185_180	180	38	15.6	2600	6.1	1700	19000	70	7.8	3000	3.8	1700	19500	65		
	VFR 185_240	240	32	11.7	2400	4.5	1700	19000	65	5.8	2800	2.9	1700	19500	59		
	VFR 185_300	300	29	9.3	2000	3.2	1700	19000	61	4.7	2300	2.0	1700	19500	55		
						$n_1 = 900 \text{ min}^{-1}$					$n_1 = 500 \text{ min}^{-1}$						
	VFR 185_90	90	53	10.0	3200	4.6	1700	19500	73	5.6	3500	2.9	1700	19500	71	171	
	VFR 185_120	120	43	7.5	3800	4.5	1700	19500	66	4.2	4200	2.9	1700	19500	63		
	VFR 185_150	150	40	6.0	3400	3.4	1700	19500	63	3.3	3700	2.2	1700	19500	60		
	VFR 185_180	180	38	5.0	3300	2.9	1700	19500	60	2.8	3600	1.8	1700	19500	57		
	VFR 185_240	240	32	3.8	2800	2.0	1700	19500	54	2.1	2900	1.2	1700	19500	53		
	VFR 185_300	300	29	3.0	2400	1.5	1700	19500	50	1.7	2500	0.91	1700	19500	48		

(-) Consulter notre service technique en donnant les détails concernant la charge radiale (sens de rotation, indexage, position)

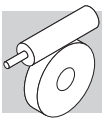

W/VF 86/185

4400 Nm



W/VF 86/185		i	η_s %	$n_1 = 1400 \text{ min}^{-1}$					$n_1 = 900 \text{ min}^{-1}$					172		
				n_2 min ⁻¹	M_{n2} Nm	P_{n1} kW	R_{n1} N	R_{n2} N	η_d %	n_2 min ⁻¹	M_{n2} Nm	P_{n1} kW	R_{n1} N		R_{n2} N	η_d %
	W/VF 86/185_280	280	31	5.0	4200	4.2	850	19500	52	3.2	4400	3.0	850	19500	49	
	W/VF 86/185_400	400	29	3.5	4200	3.2	850	19500	48	2.3	4400	2.3	850	19500	45	
	W/VF 86/185_600	600	26	2.3	4200	2.3	850	19500	45	1.5	4400	1.6	850	19500	43	
	W/VF 86/185_800	800	26	1.8	4200	1.8	850	19500	43	1.1	4400	1.3	850	19500	40	
	W/VF 86/185_920	920	26	1.5	4200	1.6	850	19500	42	1.0	4400	1.2	850	19500	38	
	W/VF 86/185_1200	1200	20	1.2	4200	1.5	850	19500	34	0.75	4400	0.99	850	19500	35	
	W/VF 86/185_1600	1600	20	0.88	4200	1.1	850	19500	35	0.56	4400	0.79	850	19500	33	
	W/VF 86/185_1840	1840	19	0.76	4200	0.98	850	19500	34	0.49	4400	0.70	850	19500	32	
	W/VF 86/185_2560	2560	16	0.55	4200	0.83	850	19500	29	0.35	4400	0.60	850	19500	27	
	W/VF 86/185_3200	3200	15	0.44	4200	0.80	850	19500	24	0.28	4400	0.59	850	19500	22	

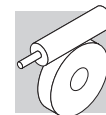

VF 210 - VFR 210

5000 Nm

		i	η_s %	$n_1 = 2800 \text{ min}^{-1}$						$n_1 = 1400 \text{ min}^{-1}$						
				n_2 min^{-1}	M_{n2} Nm	P_{n1} kW	R_{n1} N	R_{n2} N	η_d %	n_2 min^{-1}	M_{n2} Nm	P_{n1} kW	R_{n1} N	R_{n2} N	η_d %	
VF 210	VF 210_7	7	71	400	1725	79	5300	14000	91	200	2300	54	5300	16700	90	169
	VF 210_10	10	69	280	1988	65	5300	16300	90	140	2650	44	5300	19500	89	
	VF 210_15	15	63	187	2138	47	5300	19700	89	93	2850	32	5300	23700	88	
	VF 210_20	20	57	140	2325	39	4970	22000	87	70	3100	27	1100	26600	85	
	VF 210_30	30	51	93	2288	26	5300	25900	85	47	3050	18.5	1760	31500	83	
	VF 210_40	40	42	70	2625	23	—	28300	81	35	3500	17.0	—	31500	78	
	VF 210_50	50	39	56	2475	18.4	—	31000	79	28.0	3300	13.0	—	31500	76	
	VF 210_60	60	36	47	2363	15.0	—	31500	77	23.3	3015	10.0	—	31500	73	
	VF 210_80	80	31	35	2175	10.9	—	31500	73	17.5	2900	7.7	—	31500	69	
	VF 210_100	100	27	28	2025	8.5	950	31500	70	14.0	2700	6.0	—	31500	65	
					$n_1 = 900 \text{ min}^{-1}$					$n_1 = 500 \text{ min}^{-1}$						
	VF 210_7	7	71	129	2700	41	5300	18800	89	71	3400	29	5300	21800	88	169
	VF 210_10	10	69	90	3150	34	5300	21900	88	50	3800	23	5300	26000	87	
	VF 210_15	15	63	60	3300	24	5300	27000	86	33	4100	17.2	5300	31800	84	
	VF 210_20	20	57	45	3800	22	—	29900	83	25.0	4700	15.4	—	34500	81	
	VF 210_30	30	51	30.0	3400	13.4	3750	33000	80	16.7	4000	9.3	5300	34500	77	
	VF 210_40	40	42	22.5	4300	13.5	—	33000	75	12.5	5000	9.4	—	34500	71	
	VF 210_50	50	39	18.0	4000	10.5	—	33000	72	10.0	4500	7.1	—	34500	68	
VF 210_60	60	36	15.0	3720	8.5	—	33000	70	8.3	4300	6.0	—	34500	65		
VF 210_80	80	31	11.3	3300	6.0	—	33000	65	6.3	3900	4.4	—	34500	60		
VF 210_100	100	27	9.0	3000	4.6	—	33000	61	5.0	3400	3.4	1470	34500	56		

6300 Nm

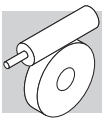

		i	η_s %	$n_1 = 2800 \text{ min}^{-1}$						$n_1 = 1400 \text{ min}^{-1}$						
				n_2 min^{-1}	M_{n2} Nm	P_{n1} kW	R_{n1} N	R_{n2} N	η_d %	n_2 min^{-1}	M_{n2} Nm	P_{n1} kW	R_{n1} N	R_{n2} N	η_d %	
VFR 210	VFR 210_30	30	68	93	3150	36	1800	22100	87	47	3800	21.8	2200	27400	86	171
	VFR 210_45	45	62	62	3300	25	1800	27000	85	31	4100	16.2	2200	33200	83	
	VFR 210_60	60	56	47	3800	22	1800	29900	82	23.0	4700	14.5	2200	34500	80	
	VFR 210_90	90	50	31	3400	14.1	1800	33000	79	15.6	4000	8.6	2200	34500	76	
	VFR 210_120	120	41	23.3	4300	14.3	1800	33000	74	11.7	5000	8.8	2200	34500	70	
	VFR 210_150	150	38	18.7	4000	11.1	1800	33000	71	9.3	4500	6.6	2200	34500	67	
	VFR 210_180	180	35	15.6	3720	8.8	1800	33000	69	7.8	4300	5.5	2200	34500	64	
	VFR 210_240	240	30	11.7	3300	6.3	1800	33000	64	5.8	3900	4.1	2200	34500	59	
	VFR 210_300	300	26	9.3	3000	4.9	1800	33000	60	4.7	3400	3.0	2200	34500	55	
					$n_1 = 900 \text{ min}^{-1}$					$n_1 = 500 \text{ min}^{-1}$						
	VFR 210_30	30	68	30.0	4800	18.1	2300	30100	84	16.7	5500	11.8	2650	34500	82	171
	VFR 210_45	45	62	20.0	4900	12.9	2300	34500	80	11.1	5600	8.4	2650	34500	78	
	VFR 210_60	60	56	15.0	5400	11.1	2300	34500	77	8.3	6000	7.1	2650	34500	74	
	VFR 210_90	90	50	10.0	4600	6.7	2300	34500	72	5.6	5150	4.3	2650	34500	70	
	VFR 210_120	120	41	7.5	5900	7.1	2300	34500	66	4.2	6300	4.4	2650	34500	63	
	VFR 210_150	150	38	6.0	5300	5.4	2300	34500	62	3.3	5900	3.5	2650	34500	59	
	VFR 210_180	180	35	5.0	4900	4.4	2300	34500	59	2.8	5400	2.8	2650	34500	56	
	VFR 210_240	240	30	3.8	4400	3.2	2300	34500	54	2.1	4800	2.1	2650	34500	50	
VFR 210_300	300	26	3.0	3600	2.3	2300	34500	49	1.7	4000	1.5	2650	34500	46		

(-) Consulter notre service technique en donnant les détails concernant la charge radiale (sens de rotation, indexage, position)



VF/VF 130/210

6500 Nm

		i	η _s %	n ₁ = 1400 min ⁻¹					n ₁ = 900 min ⁻¹							
				n ₂ min ⁻¹	M _{n2} Nm	P _{n1} kW	R _{n1} N	R _{n2} N	η _d %	n ₂ min ⁻¹	M _{n2} Nm	P _{n1} kW	R _{n1} N		R _{n2} N	η _d %
				VF/VF 130/210	VF/VF 130/210_280	280	30	5.0	6300	6.3	1500	34500	52		3.2	6500
	VF/VF 130/210_400	400	28	3.5	6300	4.6	1500	34500	50	2.3	6500	3.2	1500	34500	48	
	VF/VF 130/210_600	600	26	2.3	6300	3.6	1500	34500	43	1.5	6500	2.4	1500	34500	43	
	VF/VF 130/210_800	800	25	1.8	6300	2.8	1500	34500	41	1.1	6500	2.0	1500	34500	38	
	VF/VF 130/210_920	920	24	1.5	6300	2.7	1500	34500	37	1.0	6500	1.9	1500	34500	35	
	VF/VF 130/210_1200	1200	21	1.2	6300	2.2	—	34500	35	0.75	6500	1.5	—	34500	34	
	VF/VF 130/210_1600	1600	18	0.88	6300	1.8	—	34500	32	0.56	6500	1.2	—	34500	32	
	VF/VF 130/210_1840	1840	19	0.76	6300	1.7	—	34500	30	0.49	6500	1.2	490	34500	28	
	VF/VF 130/210_2560	2560	16	0.55	6300	1.5	1220	34500	24	0.35	6500	1.0	1500	34500	24	
	VF/VF 130/210_3200	3200	15	0.44	6300	1.3	1500	34500	22	0.28	6500	0.96	1500	34500	20	

(-) Consulter notre service technique en donnant les détails concernant la charge radiale (sens de rotation, indexage, position)

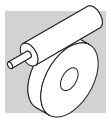

VF 250 - VFR 250

7100 Nm

	i	η_s %	$n_1 = 2800 \text{ min}^{-1}$						$n_1 = 1400 \text{ min}^{-1}$							
			n_2 min ⁻¹	M_{n2} Nm	P_{n1} kW	R_{n1} N	R_{n2} N	η_d %	n_2 min ⁻¹	M_{n2} Nm	P_{n1} kW	R_{n1} N	R_{n2} N	η_d %		
			VF 250													
VF 250_7	7	71	400	2400	109	7000	18300	92	200	3200	75	7000	21900	91	169	
VF 250_10	10	69	280	2775	89	7000	21100	91	140	3700	61	7000	25300	90		
VF 250_15	15	64	187	3000	65	7000	25100	90	93	4000	45	7000	30300	88		
VF 250_20	20	59	140	3338	56	7000	28000	88	70	4450	38	7000	33900	86		
VF 250_30	30	53	93	3000	34	7000	33400	86	47	4000	23	7000	40600	84		
VF 250_40	40	41	70	3600	32	4680	36200	82	35	4800	22	—	44000	79		
VF 250_50	50	36	56	3375	25	6370	39500	79	28.0	4500	17.0	—	47000	76		
VF 250_60	60	38	47	3375	20.6	7000	42100	80	23.3	4500	15.0	—	47000	76		
VF 250_80	80	32	35	2925	14.1	7000	47000	76	17.5	3900	10.0	—	47000	71		
VF 250_100	100	29	28	2738	11.0	7000	47000	73	14.0	3650	7.8	3010	47000	68		
			$n_1 = 900 \text{ min}^{-1}$						$n_1 = 500 \text{ min}^{-1}$							
VF 250																
VF 250_7	7	71	129	4150	63	7000	23700	90	71	5200	44	7000	27600	88	169	
VF 250_10	10	69	90	4800	51	7000	27600	89	50	6000	36	7000	32300	87		
VF 250_15	15	64	60	5300	39	7000	33200	87	33	6400	27	7000	39500	85		
VF 250_20	20	59	45	5950	33	1640	37200	85	25.0	7100	24	1910	44400	82		
VF 250_30	30	53	30.0	5500	21	7000	44900	81	16.7	6000	14.7	7000	52000	79		
VF 250_40	40	41	22.5	6500	20.0	—	48800	76	12.5	7000	13.6	—	52000	72		
VF 250_50	50	36	18.0	6200	16.2	—	50000	73	10.0	6500	11.1	—	52000	68		
VF 250_60	60	38	15.0	5600	12.2	—	50000	72	8.3	6300	8.6	4350	52000	68		
VF 250_80	80	32	11.3	5200	9.3	—	50000	67	6.3	5400	6.8	7000	52000	62		
VF 250_100	100	29	9.0	4800	7.2	3010	50000	63	5.0	5000	5.3	4160	52000	58		

9000 Nm

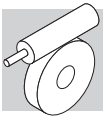

	i	η_s %	$n_1 = 2800 \text{ min}^{-1}$						$n_1 = 1400 \text{ min}^{-1}$							
			n_2 min ⁻¹	M_{n2} Nm	P_{n1} kW	R_{n1} N	R_{n2} N	η_d %	n_2 min ⁻¹	M_{n2} Nm	P_{n1} kW	R_{n1} N	R_{n2} N	η_d %		
			VFR 250													
VFR 250_30	30	68	93	4800	54	2800	27800	89	47	6000	34	3500	34000	86	171	
VFR 250_45	45	63	62	5300	41	2800	33300	87	31	6400	25	3500	41300	84		
VFR 250_60	60	58	47	5950	35	2800	37200	85	23.0	7100	21	3500	46100	81		
VFR 250_90	90	52	31	5500	22	2800	44700	81	15.6	6000	12.6	3500	52000	78		
VFR 250_120	120	40	23.3	6500	21.3	2800	48500	76	11.7	7000	12.1	3500	52000	71		
VFR 250_150	150	35	18.7	6200	16.9	2800	50000	73	9.3	6500	9.5	3500	52000	67		
VFR 250_180	180	37	15.6	5600	12.9	2800	50000	72	7.8	6300	7.7	3500	52000	67		
VFR 250_240	240	31	11.7	5200	9.7	2800	50000	67	5.8	5400	5.4	3500	52000	61		
VFR 250_300	300	28	9.3	4800	7.6	2800	50000	63	4.7	5000	4.3	3500	52000	57		
			$n_1 = 900 \text{ min}^{-1}$						$n_1 = 500 \text{ min}^{-1}$							
VFR 250																
VFR 250_30	30	68	30.0	6500	24	3700	39600	84	16.7	7600	16.1	4200	47600	83	171	
VFR 250_45	45	63	20.0	6800	17.5	3700	48000	82	11.1	7900	11.6	3500	52000	80		
VFR 250_60	60	58	15.0	7600	15.2	3700	52000	79	8.3	8600	9.9	3500	52000	76		
VFR 250_90	90	52	10.0	6500	9.3	3700	52000	74	5.6	7400	6.1	3500	52000	71		
VFR 250_120	120	40	7.5	7500	8.8	3700	52000	67	4.2	9000	6.2	3500	52000	64		
VFR 250_150	150	35	6.0	7000	7.0	3700	52000	63	3.3	8600	5.1	3500	52000	59		
VFR 250_180	180	37	5.0	6700	5.7	3700	52000	62	2.8	7600	3.8	3500	52000	59		
VFR 250_240	240	31	3.8	5800	4.1	3700	52000	56	2.1	6500	2.7	3500	52000	52		
VFR 250_300	300	28	3.0	5300	3.2	3700	52000	52	1.7	6000	2.2	3500	52000	48		

(-) Consulter notre service technique en donnant les détails concernant la charge radiale (sens de rotation, indexage, position)



VF/VF 130/250

9200 Nm

		i	η _s %	n ₁ = 1400 min ⁻¹					n ₁ = 900 min ⁻¹							
				n ₂ min ⁻¹	M _{n2} Nm	P _{n1} kW	R _{n1} N	R _{n2} N	η _d %	n ₂ min ⁻¹	M _{n2} Nm	P _{n1} kW	R _{n1} N		R _{n2} N	η _d %
VF/VF 130/250	VF/VF 130/250_280	280	29	5.0	9000	8.9	1500	52000	53	3.2	9200	6.1	1500	52000	51	172
	VF/VF 130/250_400	400	27	3.5	9000	6.7	1500	52000	49	2.3	9200	4.6	1500	52000	47	
	VF/VF 130/250_600	600	26	2.3	9000	5.0	1500	52000	44	1.5	9200	3.4	1500	52000	43	
	VF/VF 130/250_800	800	24	1.8	9000	3.9	1500	52000	42	1.1	9200	2.7	1500	52000	40	
	VF/VF 130/250_920	920	23	1.5	9000	3.9	1500	52000	37	0.98	9200	2.7	1500	52000	35	
	VF/VF 130/250_1200	1200	20	1.2	9000	3.1	—	52000	35	0.75	9200	2.2	—	52000	33	
	VF/VF 130/250_1600	1600	18	0.88	9000	2.6	—	52000	32	0.56	9200	1.8	—	52000	30	
	VF/VF 130/250_1840	1840	18	0.76	9000	2.3	—	52000	31	0.49	9200	1.6	490	52000	29	
	VF/VF 130/250_2560	2560	16	0.55	9000	2.1	1500	52000	25	0.35	9200	1.5	1500	52000	23	
	VF/VF 130/250_3200	3200	14	0.44	9000	2.0	1500	52000	21	0.28	9200	1.4	1500	52000	19	

(-) Consulter notre service technique en donnant les détails concernant la charge radiale (sens de rotation, indexage, position)

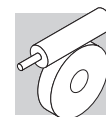

23 COMBINAISONS DES RAPPORT RÉDUCTEURS SÉRIE VF/VF, VF/W, W/VF

	Rapports										i max	
	245	350	420	560	700	840	1120	1680	2100			
VF/VF 30/44											6000	
VF 30	7	10	15	20	20	30	40	60	60		60	
VF 44	35	35	28	28	35	28	28	28	35		100	
VF/VF 30/49	240	315	420	540	720	900	1120	1440	2160	2700	6000	
VF 30	10	7	15	15	20	20	40	40	60	60	60	
VF 49	24	45	28	36	36	45	28	36	36	45	100	
VF/W 30/63	240	315	450	570	720	900	1200	1520	2280	2700	7000	
VF 30	10	7	15	15	30	30	40	40	60	60	70	
W 63	24	45	30	38	24	30	30	38	38	45	100	
VF/W 44/75	250	300	400	525	700	920	1200	1500	2100	2800	10000	
VF 44	10	10	10	35	35	46	60	60	70	70	100	
W 75	25	30	40	15	20	20	20	25	30	40	100	
VF/W 44/86	230	300	400	525	700	920	1380	1840	2116	2760	10000	
VF 44	10	10	10	35	35	46	46	46	46	60	100	
W 86	23	30	40	15	20	20	30	40	46	46	100	
VF/W 49/110	230	300	400	540	720	1080	1350	1656	2070	2800	10000	
VF 49	10	10	10	18	36	36	45	36	45	70	100	
W 110	23	30	40	30	20	30	30	46	46	40	100	
W/VF 63/130	280	400	600	760	960	1200	1520	1800	2560	3200	10000	
W 63	7	10	15	19	24	30	38	45	64	80	100	
VF 130	40	40	40	40	40	40	40	40	40	40	100	
W/VF 86/150	200	225	300	345	460	529	690	920	1380	1840	2944	10000
W 86	10	15	15	15	20	23	23	23	46	46	64	100
VF 150	20	15	20	23	23	23	30	40	30	40	46	100
W/VF 86/185	280	400	600	800	920	1200	1600	1840	2560	3200	10000	
W 86	7	10	15	20	23	30	40	46	64	80	100	
VF 185	40	40	40	40	40	40	40	40	40	40	100	
VF/VF 130/210	280	400	600	800	920	1200	1600	1840	2560	3200	10000	
VF 130	7	10	15	20	23	30	40	46	64	80	100	
VF 210	40	40	40	40	40	40	40	40	40	40	100	
VF/VF 130/250	280	400	600	800	920	1200	1600	1840	2560	3200	10000	
VF 130	7	10	15	20	23	30	40	46	64	80	100	
VF 250	40	40	40	40	40	40	40	40	40	40	100	

Les combinaisons des rapports indiquées dans le tableau sont celles recommandées par le constructeur.

Le service technique de Bonfiglioli pourra étudier la faisabilité des combinaisons autres que celles indiquées, à condition que la valeur du rapport soit inférieure à la valeur maxi indiquée dans le tableau.

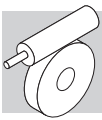

24 PREDISPOSITION MOTEUR

24.1 Moteurs standard IEC

Dans les tableaux sont indiqués les accouplements possibles en termes de dimensions.

Le choix le plus approprié du motoréducteur à utiliser doit être effectué selon les indications du paragraphe: "Sélection", ainsi qu'en fonction des tableaux de sélection, respectant en particulier la condition $S \geq f_s$.

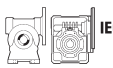
 IEC	VF 27	VF 30	VF 44	VF 49	W 63	W 75	W 86	W 110	VF 130	VF 150	VF 185	VF 210	VF 250
P27 —	7...70	—	—	—	—	—	—	—	—	—	—	—	—
P56 $\frac{B5}{B14}$	—	7...70	—	—	—	—	—	—	—	—	—	—	—
P63 $\frac{B5}{B14}$	—	7...60	7...100	7...100	—	—	—	—	—	—	—	—	—
P71 $\frac{B5}{B14}$	—	—	7...35	7...60	7...100	$\frac{7...100}{—}$	$\frac{7...100}{—}$	—	—	—	—	—	—
P80 $\frac{B5}{B14}$	—	—	—	7...28	7...100	7...100	7...100	7...100	—	—	—	—	—
P90 $\frac{B5}{B14}$	—	—	—	—	7...30	7...100	7...100	7...100	$\frac{46...100}{—}$	—	—	—	—
P100 $\frac{B5}{B14}$	—	—	—	—	—	7...100	7...100	7...100	$\frac{7...80}{—}$	$\frac{23...100}{—}$	$\frac{50...100}{—}$	—	—
P112 $\frac{B5}{B14}$	—	—	—	—	—	7...100	7...100	7...100	$\frac{7...40}{—}$	$\frac{23...100}{—}$	$\frac{50...100}{—}$	—	—
P132 B5	—	—	—	—	—	—	—	7...100	7...40 #	7...46	30...80	7...100	7...100
P160 B5	—	—	—	—	—	—	—	—	—	7...20 #	15...40	7...100	7...100
P180 B5	—	—	—	—	—	—	—	—	—	—	7...20 #	7...100	7...100
P200 B5	—	—	—	—	—	—	—	—	—	—	—	7...100	7...100
P225 B5	—	—	—	—	—	—	—	—	—	—	—	7...100	7...100

 IEC	VFR 44	VFR 49	WR 63	WR 75	WR 86	WR 110	VFR 130	VFR 150	VFR 185	VFR 210	VFR 250
S44 —	70...500	—	—	—	—	—	—	—	—	—	—
P63 B5	—	30...300	21...300	21...300	21...300	—	—	—	—	—	—
P71 B5	—	—	21...300	21...300	21...300	21...300	—	—	—	—	—
P80 B5	—	—	—	21...300	21...300	21...300	30...300	—	—	—	—
P90 B5	—	—	—	15...150	15...150	21...300	30...300	30...300	30...300	—	—
P100 B5	—	—	—	—	—	21...300	30...300 #	30...300	30...300	30...300	30...300
P112 B5	—	—	—	—	—	21...300	30...300 #	30...300	30...300	30...300	30...300
P132 B5	—	—	—	—	—	—	—	25...50 #	25...100 #	30...300	30...300

■ Rapport de l'étage à l'entrée hélicoidal $i = 1.5$

Les accouplements repérés par [#] sont dotés d'une clavette à hauteur réduite, livrées avec le réducteur.

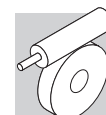

IEC		VF/VF 30/44	VF/VF 30/49	VF/W 30/63	VF/W 44/75	VF/W 44/86	VF/W 49/110	W/VF 63/130	W/VF 86/150	W/VF 86/185	VF/VF 130/210	VF/VF 130/250
P56	$\frac{B5}{B14}$	245...2100	240...2700	240...2700	—	—	—	—	—	—	—	—
P63	$\frac{B5}{B14}$	245...2100	240...2700	240...2700	250...2800	230...2760	230...2800	—	—	—	—	—
P71	$\frac{B5}{B14}$	—	—	—	250...700	230...700	230...2400	280...3200	$\frac{200...2944}{—}$	$\frac{280...3200}{—}$	—	—
P80	$\frac{B5}{B14}$	—	—	—	—	—	230...540	280...3200	200...2944	280...3200	—	—
P90	$\frac{B5}{B14}$	—	—	—	—	—	—	280...1200	200...2944	280...3200	$\frac{280...3200}{—}$	$\frac{280...3200}{—}$
P100	$\frac{B5}{B14}$	—	—	—	—	—	—	—	200...2944	280...3200	$\frac{280...3200}{—}$	$\frac{280...3200}{—}$
P112	$\frac{B5}{B14}$	—	—	—	—	—	—	—	200...2944	280...3200	$\frac{280...3200}{—}$	$\frac{280...3200}{—}$
P132	B5	—	—	—	—	—	—	—	—	—	280...1600 #	280...1600 #

Les accouplements repérés par [#] sont dotés d'une clavette à hauteur réduite, livrées avec le réducteur.

24.2 Moteur compact

	M1	M2	M3
W 63	7 ... 100	7 ... 100	⊖
W 75	7 ... 100	7 ... 100	7 ... 100
W 86	7 ... 100	7 ... 100	7 ... 100
W 110	⊖	7 ... 100	7 ... 100

	M1	M2	M3
W/VF 63/130	280 ... 3200	280 ... 3200	⊖
W/VF 86/150	200 ... 2944	200 ... 2944	200 ... 2944
W/VF 86/185	280 ... 3200	280 ... 3200	280 ... 3200

24.3 Moteurs non normalisés

Pour l'accouplement à des moteurs électriques non normalisés, l'interface moteur des réducteurs série VF et W peut être configurée avec des combinaisons arbre d'entrée/bride hybrides, c'est-à-dire ne répondant à la norme CEI. La combinaison arbre/bride est exprimée au moyen des diamètres respectifs et sur la représentation simplifiée ci-après.

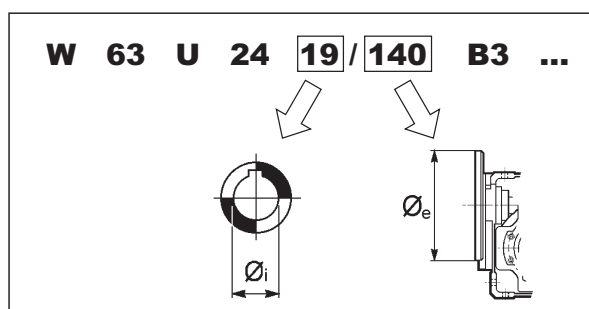

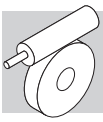

Les associations arbre/bride disponibles ainsi que les rapports de transmission auxquelles elles sont limitées sont exprimées dans les tableaux suivants.

		80	90	105	120	140	160	200
VF 30	9		$7 \leq i \leq 70$	⊖		$7 \leq i \leq 70$	⊖	⊖
	11	$7 \leq i \leq 60$		⊖	$7 \leq i \leq 60$		⊖	⊖
VF 44	HS	⊖	$7 \leq i \leq 100$	$7 \leq i \leq 100$	⊖	$7 \leq i \leq 100$	$7 \leq i \leq 100$	⊖
	11	⊖		$7 \leq i \leq 100$	⊖		$7 \leq i \leq 100$	⊖
	14	⊖	$7 \leq i \leq 35$		⊖	$7 \leq i \leq 35$		⊖
VF 49	HS	⊖	$7 \leq i \leq 100$	$7 \leq i \leq 100$	$7 \leq i \leq 100$	$7 \leq i \leq 100$	$7 \leq i \leq 100$	$7 \leq i \leq 100$
	11	⊖		$7 \leq i \leq 100$	$7 \leq i \leq 100$		$7 \leq i \leq 100$	$7 \leq i \leq 100$
	14	⊖	$7 \leq i \leq 60$		$7 \leq i \leq 60$	$7 \leq i \leq 60$		$7 \leq i \leq 60$
	19	⊖	$7 \leq i \leq 28$	$7 \leq i \leq 28$		$7 \leq i \leq 28$	$7 \leq i \leq 28$	
W 63	19	⊖	⊖	⊖	⊖	$7 \leq i \leq 100$	⊖	
W 75	14	⊖	⊖	⊖	⊖	⊖		$7 \leq i \leq 100$
	19	⊖	⊖	⊖		$7 \leq i \leq 100$	$7 \leq i \leq 100$	
	24	⊖	⊖	⊖	$7 \leq i \leq 100$		$7 \leq i \leq 100$	
W 86	14	⊖	⊖	⊖	⊖	⊖		$7 \leq i \leq 100$
	19	⊖	⊖	⊖		$7 \leq i \leq 100$	$7 \leq i \leq 100$	
	24	⊖	⊖	⊖	$7 \leq i \leq 100$		$7 \leq i \leq 100$	
W 110	19	⊖	⊖	⊖		$7 \leq i \leq 100$	⊖	⊖
	24	⊖	⊖	⊖	$7 \leq i \leq 100$		⊖	⊖

Couplage standard

Certaines associations hybrides arbre/bride sont aussi réalisable pour les réducteurs VF avec entraxe de 130 et plus. Dans ce cas, contacter le Service Technique Bonfiglioli pour connaître la disponibilité. Les configurations résultant des tableaux ci-dessus sont possibles exclusivement du point de vue de la compatibilité géométrique.

La compatibilité mécanique de l'ensemble moteur-réducteur doit être ultérieurement vérifiée en utilisant les tableaux habituels de sélection par puissance/vitesse.

Plus particulièrement, il convient d'éviter les associations moteur qui génèrent des facteurs de sécurité $S < 0,9$.

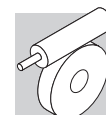

25 MOMENTS D'INERTIE

Les tableaux techniques suivants indiquent les valeurs du moment d'inertie J_r [Kgm²] du niveau de l'arbre rapide du réducteur; pour une plus grande facilité de lecture, nous vous prions de noter les définitions des symboles employés :

	<p>Les valeurs liées à ces symboles sont à assigner au réducteur compact, sans moteur. Dans ce cas, afin d'avoir le moment d'inertie total du motoréducteur, on devra additionner la valeur correspondant au réducteur compact, à celle du moteur à assembler (donnée que l'on peut repérer dans les tableaux des caractéristiques techniques des moteurs électriques).</p>		<p>Les valeurs liées à ces symboles sont à assigner au réducteur prédisposé pour accouplement moteur seulement (taille IEC...).</p>
			<p>Les valeurs liées au réducteur sont assignées à ce symbole.</p>

VF 27



		i	J (•10 ⁻⁴) [kgm ²]				
			P27				HS
VF 27	VF 27_7	7	0.02	—	—	—	0.02
	VF 27_10	10	0.01	—	—	—	0.01
	VF 27_15	15	0.01	—	—	—	0.01
	VF 27_20	20	0.01	—	—	—	0.01
	VF 27_30	30	0.01	—	—	—	0.01
	VF 27_40	40	0.01	—	—	—	0.01
	VF 27_60	60	0.01	—	—	—	0.01
	VF 27_70	70	0.01	—	—	—	0.01

VF 30

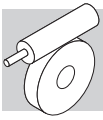
		i	J (•10 ⁻⁴) [kgm ²]				
			P56	P63			HS
VF 30	VF 30_7	7	0.08	0.07	—	—	0.04
	VF 30_10	10	0.07	0.06	—	—	0.03
	VF 30_15	15	0.07	0.06	—	—	0.03
	VF 30_20	20	0.06	0.06	—	—	0.03
	VF 30_30	30	0.06	0.06	—	—	0.03
	VF 30_40	40	0.06	0.06	—	—	0.03
	VF 30_60	60	0.06	0.05	—	—	0.02
	VF 30_70	70	0.06	—	—	—	0.02



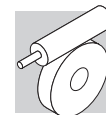

VF 44 - VFR 44

		i	J ($\cdot 10^{-4}$) [kgm ²]					
			 S44	P63	P71	 HS		
VF 44	VF 44_7	7	—	0.29	0.27	—	—	0.18
	VF 44_10	10	—	0.24	0.22	—	—	0.14
	VF 44_14	14	—	0.23	0.21	—	—	0.12
	VF 44_20	20	—	0.19	0.18	—	—	0.09
	VF 44_28	28	—	0.21	0.19	—	—	0.11
	VF 44_35	35	—	0.19	0.18	—	—	0.09
	VF 44_46	46	—	0.18	—	—	—	0.08
	VF 44_60	60	—	0.17	—	—	—	0.07
	VF 44_70	70	—	0.17	—	—	—	0.07
	VF 44_100	100	—	0.17	—	—	—	0.07
VFR 44	VFR 44_70	70	0.21	—	—	—	—	—
	VFR 44_100	100	0.20	—	—	—	—	—
	VFR 44_140	140	0.20	—	—	—	—	—
	VFR 44_175	175	0.20	—	—	—	—	—
	VFR 44_230	230	0.20	—	—	—	—	—
	VFR 44_300	300	0.20	—	—	—	—	—
	VFR 44_350	350	0.20	—	—	—	—	—
	VFR 44_500	500	0.20	—	—	—	—	—







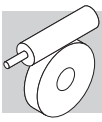

VF 49 - VFR 49

		i	J ($\cdot 10^{-4}$) [kgm ²]					
			P63	P71	 P80	 	 HS	
VF 49	VF 49_7	7	0.69	0.67	0.61	—	—	0.42
	VF 49_10	10	0.61	0.60	0.53	—	—	0.34
	VF 49_14	14	0.58	0.57	0.5	—	—	0.31
	VF 49_18	18	0.54	0.53	0.46	—	—	0.27
	VF 49_24	24	0.52	0.5	0.44	—	—	0.24
	VF 49_28	28	0.56	0.54	0.48	—	—	0.28
	VF 49_36	36	0.53	0.51	—	—	—	0.25
	VF 49_45	45	0.51	0.49	—	—	—	0.24
	VF 49_60	60	0.50	0.48	—	—	—	0.23
	VF 49_70	70	0.50	—	—	—	—	0.22
	VF 49_80	80	0.49	—	—	—	—	0.22
VF 49_100	100	0.49	—	—	—	—	0.22	
VFR 49	VFR 49_30	30	0.74	—	—	—	—	0.94
	VFR 49_42	42	0.73	—	—	—	—	0.93
	VFR 49_54	54	0.73	—	—	—	—	0.93
	VFR 49_72	72	0.73	—	—	—	—	0.93
	VFR 49_84	84	0.73	—	—	—	—	0.93
	VFR 49_108	108	0.73	—	—	—	—	0.93
	VFR 49_135	135	0.73	—	—	—	—	0.93
	VFR 49_180	180	0.73	—	—	—	—	0.93
	VFR 49_210	210	0.72	—	—	—	—	0.92
	VFR 49_240	240	0.72	—	—	—	—	0.92
	VFR 49_300	300	0.72	—	—	—	—	0.92



W 63 - WR 63

		i	J ($\cdot 10^{-4}$) [kgm ²]									
						   						 
			S1	S2	S3	P63	P71	P80	P90			HS
W 63	W 63_7	7	3.4	3.6	—	—	3.5	3.5	3.5	—	—	3.6
	W 63_10	10	3.1	3.3	—	—	3.2	3.3	3.2	—	—	3.3
	W 63_12	12	3.1	3.3	—	—	3.1	3.2	3.1	—	—	3.3
	W 63_15	15	3.0	3.2	—	—	3.0	3.1	3.0	—	—	3.2
	W 63_19	19	2.9	3.1	—	—	2.9	3.0	2.9	—	—	3.1
	W 63_24	24	2.8	3.1	—	—	2.9	3.0	2.9	—	—	3.0
	W 63_30	30	2.9	3.1	—	—	2.9	3.0	2.9	—	—	3.1
	W 63_38	38	2.8	3.1	—	—	2.9	3.0	2.9	—	—	3.0
	W 63_45	45	2.8	3.0	—	—	2.9	2.9	2.9	—	—	3.0
	W 63_64	64	2.8	3.0	—	—	2.8	2.9	2.8	—	—	3.0
	W 63_80	80	2.8	3.0	—	—	2.8	2.9	2.8	—	—	3.0
W 63_100	100	2.8	3.0	—	—	2.8	2.9	2.8	—	—	2.9	
WR 63	WR 63_21	21	—	—	—	0.84	0.83	—	—	—	—	0.81
	WR 63_30	30	—	—	—	0.81	0.80	—	—	—	—	0.78
	WR 63_36	36	—	—	—	0.81	0.80	—	—	—	—	0.77
	WR 63_45	45	—	—	—	0.80	0.79	—	—	—	—	0.76
	WR 63_57	57	—	—	—	0.79	0.78	—	—	—	—	0.75
	WR 63_72	72	—	—	—	0.78	0.77	—	—	—	—	0.74
	WR 63_90	90	—	—	—	0.79	0.78	—	—	—	—	0.75
	WR 63_114	114	—	—	—	0.78	0.77	—	—	—	—	0.74
	WR 63_135	135	—	—	—	0.78	0.77	—	—	—	—	0.74
	WR 63_192	192	—	—	—	0.77	0.76	—	—	—	—	0.74
	WR 63_240	240	—	—	—	0.77	0.76	—	—	—	—	0.74
WR 63_300	300	—	—	—	0.77	0.76	—	—	—	—	0.73	

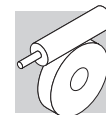

W 75 - WR 75

		i	J ($\cdot 10^{-4}$) [kgm ²]									
			 S1 S2 S3			 P63 P71 P80 P90 P100 P112						 HS
W 75	W 75_7	7	6.9	6.6	6.6	—	6.9	7.0	6.9	6.9	6.9	7.3
	W 75_10	10	6.4	6.1	6.1	—	6.4	6.4	6.3	5.7	5.7	6.8
	W 75_15	15	6.1	5.8	5.8	—	6.1	6.1	6.0	5.3	5.3	6.5
	W 75_20	20	5.9	5.6	5.6	—	5.9	5.9	5.9	5.2	5.2	6.3
	W 75_25	25	5.9	5.6	5.6	—	6.0	6.0	5.9	5.2	5.2	6.3
	W 75_30	30	5.9	5.6	5.6	—	5.9	5.9	5.9	5.2	5.2	6.3
	W 75_40	40	5.9	5.6	5.6	—	5.9	5.9	5.8	5.2	5.2	6.3
	W 75_50	50	5.9	5.6	5.6	—	5.9	5.9	5.8	5.1	5.1	6.2
	W 75_60	60	5.8	5.5	5.5	—	5.8	5.9	5.8	5.1	5.1	6.2
	W 75_80	80	5.8	5.5	5.5	—	5.8	5.8	5.8	5.1	5.1	6.2
W 75_100	100	5.8	5.5	5.5	—	5.8	5.8	5.7	5.0	5.0	6.2	
WR 75	WR 75_21	21	—	—	—	1.2	1.2	2.1	—	—	—	1.9
	WR 75_30	30	—	—	—	1.1	1.1	2.1	—	—	—	1.1
	WR 75_45	45	—	—	—	1.1	1.1	2.0	—	—	—	1.1
	WR 75_60	60	—	—	—	1.1	1.1	2.0	—	—	—	1.0
	WR 75_75	75	—	—	—	1.1	1.1	2.0	—	—	—	1.0
	WR 75_90	90	—	—	—	1.1	1.1	2.0	—	—	—	1.0
	WR 75_120	120	—	—	—	1.1	1.1	2.0	—	—	—	1.0
	WR 75_150	150	—	—	—	1.1	1.1	2.0	—	—	—	1.0
	WR 75_180	180	—	—	—	1.1	1.1	2.0	—	—	—	1.0
	WR 75_240	240	—	—	—	1.1	1.1	2.0	—	—	—	1.0
WR 75_300	300	—	—	—	1.1	1.1	2.0	—	—	—	1.0	

		J ($\cdot 10^{-4}$) [kgm ²]
i		 P90

WR 75_P90 B5	WR 75_15	15	6.0
	WR 75_22.5	22.5	5.9
	WR 75_30	30	5.8
	WR 75_37.5	37.5	5.8
	WR 75_45	45	5.8
	WR 75_60	60	5.8
WR 75_75	75	5.8	

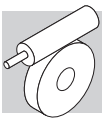

W 86 - WR 86

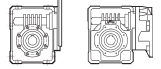
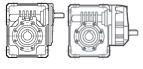
		i	J ($\cdot 10^{-4}$) [kgm ²]									
			 S1 S2 S3			 P63 P71 P80 P90 P100					 HS	
W 86	W 86_7	7	9.7	9.4	9.4	—	9.7	9.7	9.6	9.6	—	10.1
	W 86_10	10	8.4	8.1	8.1	—	8.4	8.4	8.3	7.7	—	8.9
	W 86_15	15	7.7	7.4	7.4	—	7.7	7.7	7.7	7.0	—	8.2
	W 86_20	20	6.9	6.6	6.6	—	6.9	7.0	6.9	6.2	—	7.4
	W 86_23	23	6.8	6.5	6.5	—	6.8	6.9	6.8	6.1	—	7.3
	W 86_30	30	7.3	7.0	7.0	—	7.3	7.3	7.3	6.6	—	7.8
	W 86_40	40	6.7	6.4	6.4	—	6.7	6.7	6.6	6.0	—	7.2
	W 86_46	46	6.7	6.4	6.4	—	6.7	6.7	6.6	5.9	—	7.1
	W 86_56	56	6.6	6.3	6.3	—	6.6	6.7	6.6	5.9	—	7.1
	W 86_64	64	6.6	6.3	6.3	—	6.6	6.6	6.5	5.9	—	7.1
	W 86_80	80	6.6	6.3	6.3	—	6.6	6.6	6.5	5.9	—	7.1
W 86_100	100	6.4	6.1	6.1	—	6.4	6.5	6.4	5.7	—	6.9	
WR 86	WR 86_21	21	—	—	—	1.5	1.5	2.4	—	—	—	2.2
	WR 86_30	30	—	—	—	1.4	1.3	2.3	—	—	—	1.3
	WR 86_45	45	—	—	—	1.3	1.3	2.2	—	—	—	1.2
	WR 86_60	60	—	—	—	1.2	1.2	2.1	—	—	—	1.2
	WR 86_69	69	—	—	—	1.2	1.2	2.1	—	—	—	1.1
	WR 86_90	90	—	—	—	1.2	1.2	2.2	—	—	—	1.2
	WR 86_120	120	—	—	—	1.2	1.2	2.1	—	—	—	1.1
	WR 86_138	138	—	—	—	1.2	1.2	2.1	—	—	—	1.1
	WR 86_168	168	—	—	—	1.2	1.2	2.1	—	—	—	1.1
	WR 86_192	192	—	—	—	1.2	1.1	2.1	—	—	—	1.1
	WR 86_240	240	—	—	—	1.2	1.1	2.1	—	—	—	1.1
WR 86_300	300	—	—	—	1.1	1.1	2.1	—	—	—	1.1	

		i	J ($\cdot 10^{-4}$) [kgm ²]
			 P90
WR 86_P90 B5	WR 86_15	15	6.9
	WR 86_22.5	22.5	6.6
	WR 86_30	30	6.3
	WR 86_34.5	34.5	6.2
	WR 86_45	45	6.4
	WR 86_60	60	6.2
	WR 86_69	69	6.1
WR 86_84	84	6.1	

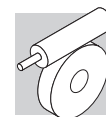

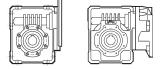
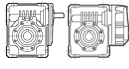

W 110 - WR 110

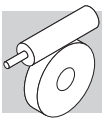
		i	J ($\cdot 10^{-4}$) [kgm ²]									
												
			S1	S2	S3	P63	P71	P80	P90	P100	P132	HS
W 110	W 110_7	7	—	22	22	—	—	23	23	23	28	23
	W 110_10	10	—	19	19	—	—	19	19	24	24	20
	W 110_15	15	—	17	17	—	—	17	17	22	22	17
	W 110_20	20	—	14	14	—	—	14	14	19	19	15
	W 110_23	23	—	14	14	—	—	14	14	19	19	15
	W 110_30	30	—	15	15	—	—	16	16	20	20	16
	W 110_40	40	—	13	13	—	—	14	14	19	19	14
	W 110_46	46	—	13	13	—	—	13	13	18	18	14
	W 110_56	56	—	13	13	—	—	13	13	18	18	14
	W 110_64	64	—	13	13	—	—	13	13	18	18	14
	W 110_80	80	—	13	13	—	—	13	13	18	18	14
W 110_100	100	—	13	13	—	—	13	13	18	18	14	
WR 110	WR 110_21	21	—	—	—	—	3.0	9.0	8.8	8.9	—	9.2
	WR 110_30	30	—	—	—	—	2.5	8.6	8.4	8.4	—	8.8
	WR 110_45	45	—	—	—	—	2.3	8.3	8.2	8.2	—	8.5
	WR 110_60	60	—	—	—	—	2.0	8.1	7.9	7.9	—	8.3
	WR 110_69	69	—	—	—	—	2.0	8.0	7.9	7.9	—	8.2
	WR 110_90	90	—	—	—	—	2.2	8.2	8.1	8.1	—	8.4
	WR 110_120	120	—	—	—	—	1.9	8.0	7.8	7.9	—	8.2
	WR 110_138	138	—	—	—	—	1.9	8.0	7.8	7.8	—	8.2
	WR 110_168	168	—	—	—	—	1.9	8.0	7.8	7.8	—	8.1
	WR 110_192	192	—	—	—	—	1.9	7.9	7.8	7.8	—	8.1
	WR 110_240	240	—	—	—	—	1.9	7.9	7.8	7.8	—	8.1
WR 110_300	300	—	—	—	—	1.9	7.9	7.8	7.8	—	8.1	



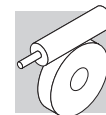

VF 130 - VFR 130

		i	J ($\cdot 10^{-4}$) [kgm ²]					HS
			P80	P90	 P100	 P112	P132	
VF 130	VF 130_7	7	—	—	36	36	35	31
	VF 130_10	10	—	—	27	27	25	22
	VF 130_15	15	—	—	20	20	18	15
	VF 130_20	20	—	—	17	17	15	11
	VF 130_23	23	—	—	16	16	14	11
	VF 130_30	30	—	—	17	17	15	12
	VF 130_40	40	—	—	15	15	14	9.9
	VF 130_46	46	—	14	14	—	—	8.2
	VF 130_56	56	—	13	13	—	—	7.8
	VF 130_64	64	—	13	13	—	—	7.4
	VF 130_80	80	—	13	12	—	—	7.0
VF 130_100	100	—	13	—	—	—	8.9	
VFR 130	VFR 130_30	30	5.3	5.3	5.2	5.2	—	5.7
	VFR 130_45	45	4.5	4.5	4.4	4.4	—	4.9
	VFR 130_60	60	4.2	4.1	4.1	4.1	—	4.6
	VFR 130_69	69	4.1	4.0	4.0	4.0	—	4.5
	VFR 130_90	90	4.2	4.1	4.1	4.1	—	4.6
	VFR 130_120	120	4.0	3.9	4.0	4.0	—	4.4
	VFR 130_138	138	3.8	3.8	3.7	3.7	—	4.2
	VFR 130_168	168	3.8	3.7	3.7	3.7	—	4.1
	VFR 130_192	192	3.7	3.7	3.6	3.6	—	4.1
	VFR 130_240	240	3.7	3.6	3.6	3.6	—	4.1
	VFR 130_300	300	3.9	3.8	3.8	3.8	—	4.3



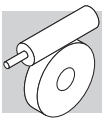

VF 150 - VFR 150

		i	J ($\cdot 10^{-4}$) [kgm ²]					HS
			P80	P90			P132	
VF 150	VF 150_7	7	—	—	—	—	58	50
	VF 150_10	10	—	—	—	—	44	35
	VF 150_15	15	—	—	—	—	29	21
	VF 150_20	20	—	—	—	—	27	19
	VF 150_23	23	—	—	28	28	26	17
	VF 150_30	30	—	—	31	31	29	21
	VF 150_40	40	—	—	26	26	24	16
	VF 150_46	46	—	—	24	24	22	13
	VF 150_56	56	—	25	24	24	—	13
	VF 150_64	64	—	24	23	23	—	12
	VF 150_80	80	—	23	22	22	—	11
	VF 150_100	100	—	23	22	22	—	11
VFR 150	VFR 150_25	25	—	—	—	15	—	—
	VFR 150_30	30	10	10	10	—	—	11
	VFR 150_37.5	37.5	—	—	—	13	—	—
	VFR 150_45	45	8.8	8.8	8.8	—	—	9.7
	VFR 150_50	50	—	—	—	12	—	—
	VFR 150_60	60	8.4	8.3	8.3	—	—	9.2
	VFR 150_69	69	8.4	8.4	8.4	—	—	9.3
	VFR 150_90	90	8.3	8.7	8.7	—	—	9.7
	VFR 150_120	120	8.3	8.2	8.2	—	—	9.2
	VFR 150_138	138	8.0	7.9	7.9	—	—	8.9
	VFR 150_168	168	7.9	7.9	7.9	—	—	8.9
	VFR 150_192	192	7.9	7.8	7.8	—	—	8.8
	VFR 150_240	240	7.7	7.7	7.7	—	—	8.6
VFR 150_300	300	7.7	7.7	7.7	—	—	8.6	



VF 185 - VFR 185

		i	J ($\cdot 10^{-4}$) [kgm ²]						HS
			P90	P100	 P112	 P132	P160	P180	
VF 185	VF 185_7	7	—	—	—	—	—	146	128
	VF 185_10	10	—	—	—	—	—	108	91
	VF 185_15	15	—	—	—	—	70	88	50
	VF 185_20	20	—	—	—	—	69	66	48
	VF 185_30	30	—	—	—	58	54	—	34
	VF 185_40	40	—	—	—	63	61	—	41
	VF 185_50	50	—	59	59	58	—	—	35
	VF 185_60	60	—	55	55	53	—	—	31
	VF 185_80	80	—	52	52	51	—	—	28
	VF 185_100	100	—	51	51	—	—	—	27
VFR 185	VFR 185_25	25	—	—	—	24	—	—	—
	VFR 185_37.5	37.5	—	—	—	17	—	—	—
	VFR 185_50	50	—	—	—	17	—	—	—
	VFR 185_75	75	—	—	—	15	—	—	—
	VFR 185_100	100	—	—	—	16	—	—	—
	VFR 185_30	30	17	17	17	—	—	—	18
	VFR 185_45	45	12	12	12	—	—	—	13
	VFR 185_60	60	12	12	12	—	—	—	13
	VFR 185_90	90	10	10	10	—	—	—	11
	VFR 185_120	120	11	11	11	—	—	—	12
	VFR 185_150	150	10	10	10	—	—	—	11
	VFR 185_180	180	9.9	9.9	9.9	—	—	—	11
	VFR 185_240	240	9.6	9.6	9.6	—	—	—	11
	VFR 185_300	300	9.5	9.4	9.4	—	—	—	10

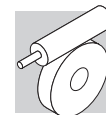

VF 210 - VFR 210

		i	J ($\cdot 10^{-4}$) [kgm ²]							HS
			P100	P112	P132	P160	P180	P200	P225	
VF 210	VF 210_7	7	—	—	286	286	286	286	286	286
	VF 210_10	10	—	—	177	177	177	177	177	177
	VF 210_15	15	—	—	120	120	120	120	120	120
	VF 210_20	20	—	—	116	116	116	116	116	116
	VF 210_30	30	—	—	81	81	81	81	81	81
	VF 210_40	40	—	—	98	98	98	98	98	98
	VF 210_50	50	—	—	84	84	84	84	84	84
	VF 210_60	60	—	—	75	75	75	75	75	75
	VF 210_80	80	—	—	68	68	68	68	68	68
	VF 210_100	100	—	—	63	63	63	63	63	63
VFR 210	VFR 210_30	30	48	48	47	47	—	—	—	51
	VFR 210_45	45	41	41	41	41	—	—	—	45
	VFR 210_60	60	41	41	41	40	—	—	—	45
	VFR 210_90	90	37	37	37	36	—	—	—	41
	VFR 210_120	120	39	39	39	38	—	—	—	43
	VFR 210_150	150	37	37	37	37	—	—	—	41
	VFR 210_180	180	36	36	36	36	—	—	—	40
	VFR 210_240	240	36	36	36	35	—	—	—	39
	VFR 210_300	300	35	35	35	34	—	—	—	39

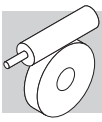

VF 250 - VFR 250

		i	J ($\cdot 10^{-4}$) [kgm ²]							HS
			P100	P112	P132	P160	P180	P200	P225	
VF 250	VF 250_7	7	—	—	620	620	620	620	620	620
	VF 250_10	10	—	—	387	387	387	387	387	387
	VF 250_15	15	—	—	266	266	266	266	266	266
	VF 250_20	20	—	—	242	242	242	242	242	242
	VF 250_30	30	—	—	184	184	184	184	184	184
	VF 250_40	40	—	—	241	241	241	241	241	241
	VF 250_50	50	—	—	240	240	240	240	240	240
	VF 250_60	60	—	—	158	158	158	158	158	158
	VF 250_80	80	—	—	160	160	160	160	160	160
	VF 250_100	100	—	—	149	149	149	149	149	149
VFR 250	VFR 250_30	30	71	71	71	70	—	—	—	75
	VFR 250_45	45	58	58	57	57	—	—	—	61
	VFR 250_60	60	55	55	55	54	—	—	—	58
	VFR 250_90	90	48	48	48	48	—	—	—	52
	VFR 250_120	120	55	55	54	54	—	—	—	58
	VFR 250_150	150	55	55	54	54	—	—	—	58
	VFR 250_180	180	46	46	45	45	—	—	—	49
	VFR 250_240	240	46	46	45	45	—	—	—	49
	VFR 250_300	300	45	45	44	44	—	—	—	48

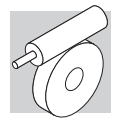

26 DIMENSIONS MOTORÉDUCTEUR ET RÉDUCTEUR PRÉDISPOSÉ POUR LIAISON A MOTEUR IEC

VF 27...BN27

A

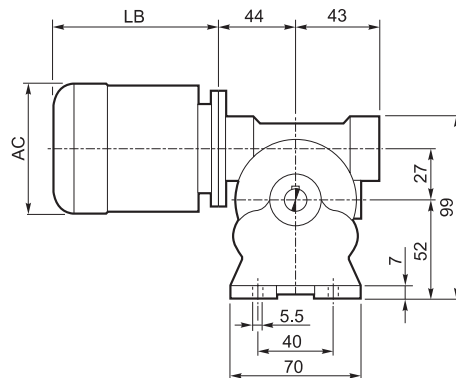
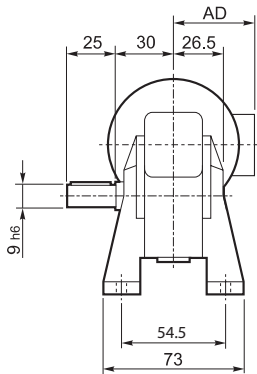

N

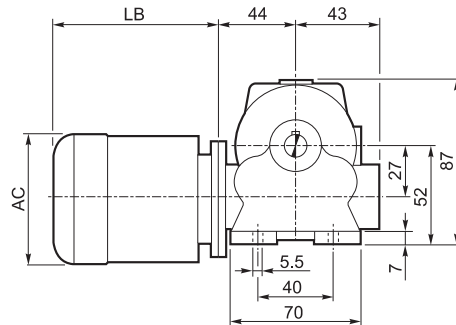
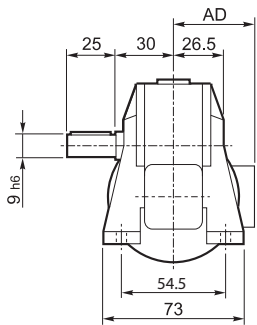

V

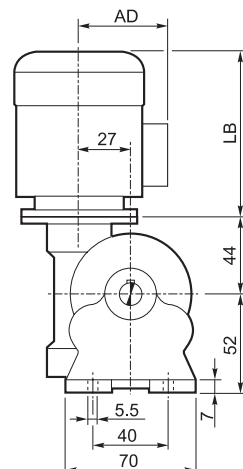
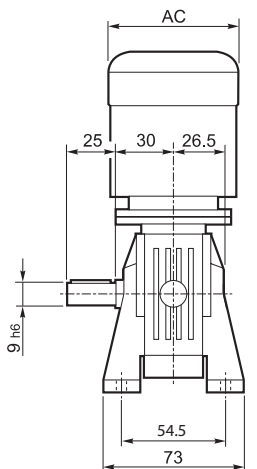

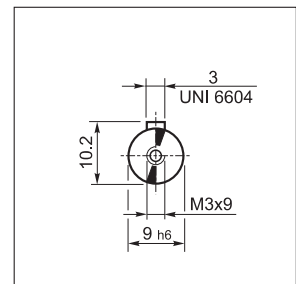

OUTPUT

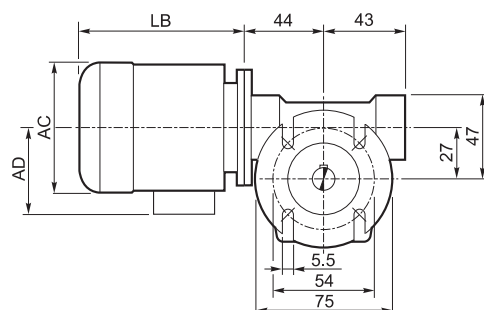
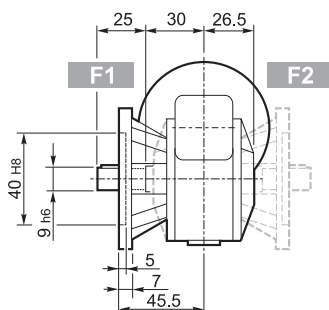

F



	P_n kW	n min ⁻¹	M_n Nm	η %	$\text{COS}\phi$	I_n A (400V)	$\frac{I_s}{I_n}$	$\frac{M_s}{M_n}$	$\frac{M_a}{M_n}$	J_m ($\cdot 10^{-4}$) kgm ²	 Kg	LB	AC	AD
BN 27A4	0.04	1350	0.28	36	0.57	0.28	2.3	2.0	1.8	0.56	2.8	132	103	76
BN 27B4	0.06	1360	0.42	39	0.57	0.39	2.5	2.2	1.9	0.76	3.1	149	103	76
BN 27C4	0.09	1380	0.63	46	0.65	0.43	2.8	2.3	1.9	1.49	3.3	175	112	94

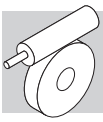

VF 30...P (IEC)

A

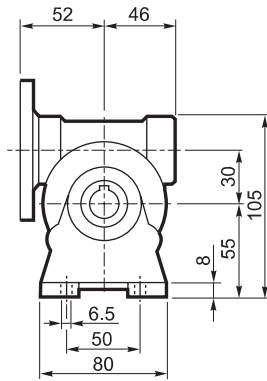
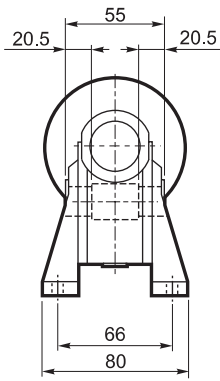

N

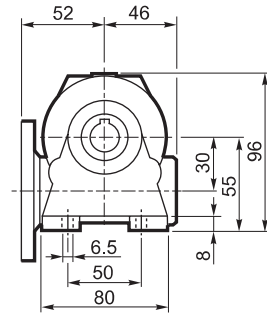
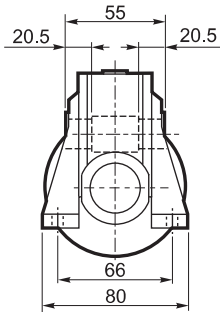

V

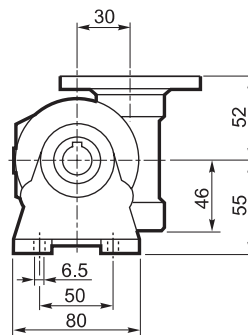
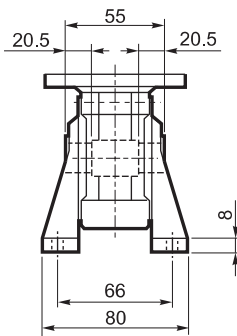

P

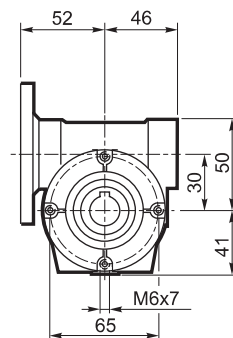
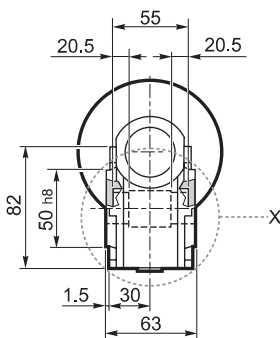

INPUT

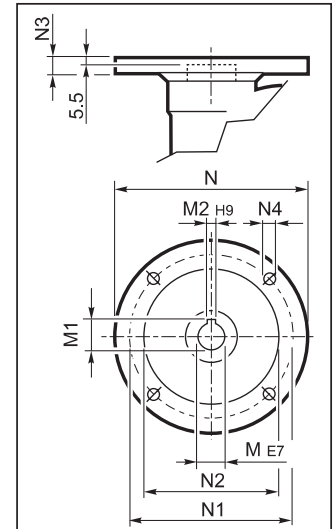

P56 B14

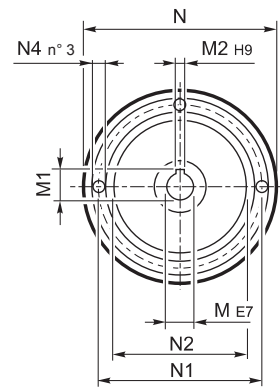

OUTPUT

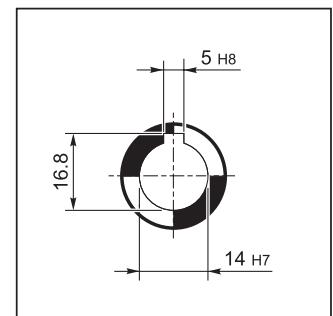

X

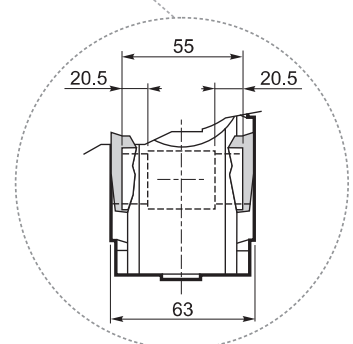

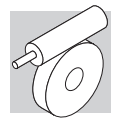

VF 30...P (IEC)

F

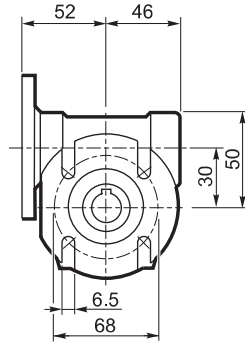
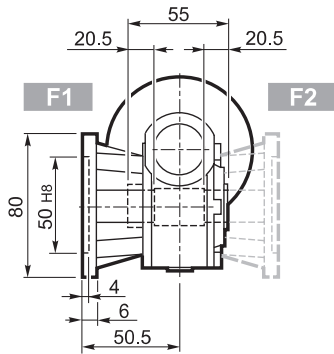

U

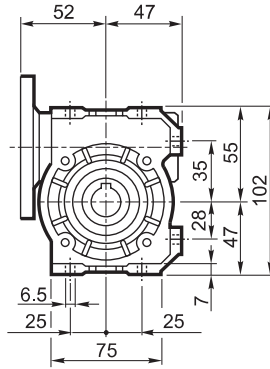
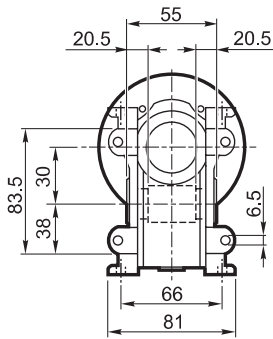

INPUT

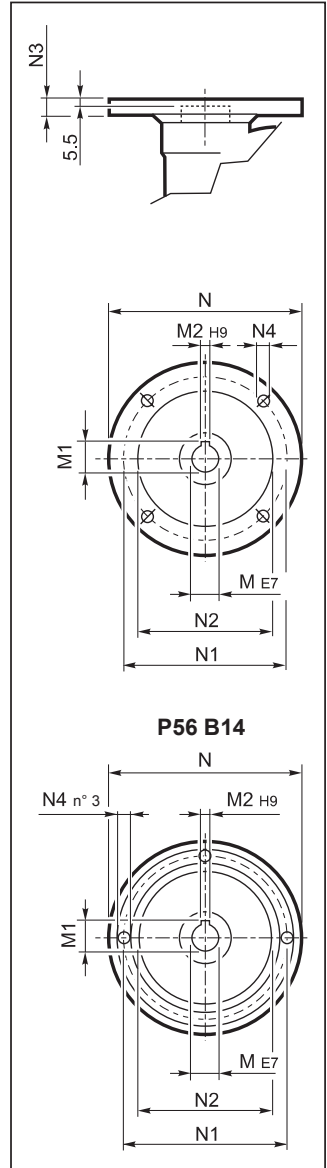

OUTPUT

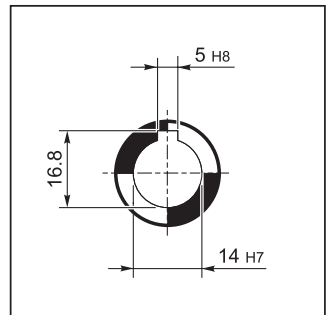

		M	M1	M2	N	N1	N2	N3	N4	
VF 30	P56 B5	9	10.4	3	120	100	80	7	7	1.1
VF 30	P56 B14	9	10.4	3	80	65	50	7	5.5	
VF 30	P63 B5	11	12.8	4	140	115	95	8	9.5	
VF 30	P63 B14	11	12.8	4	90	75	60	6	5.5	

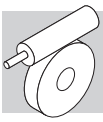

VF 44...P (IEC)

A

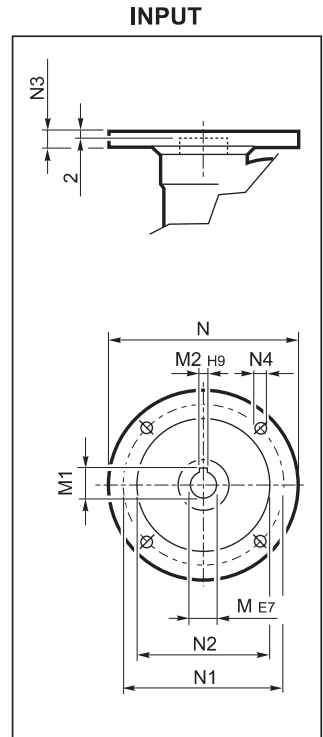
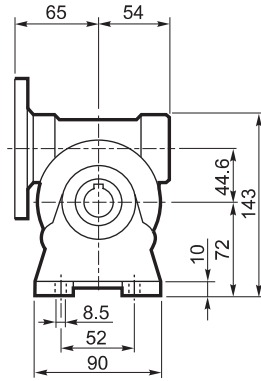
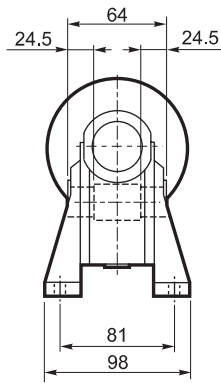

N

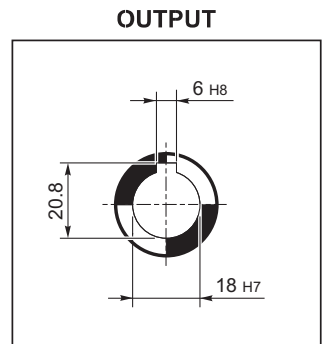
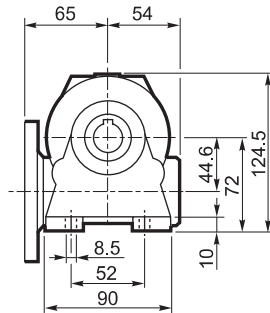
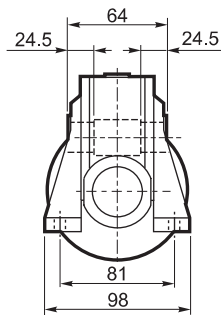

V

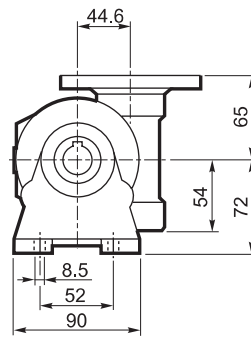
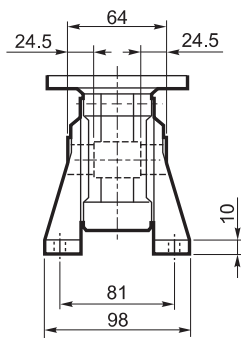

P

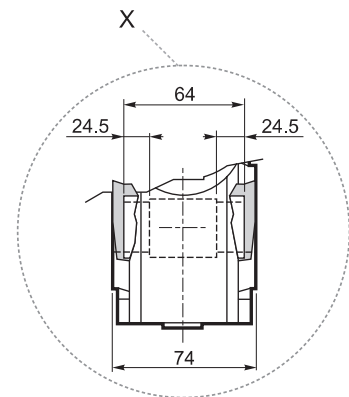
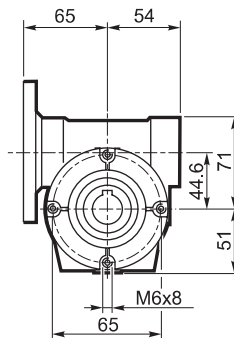
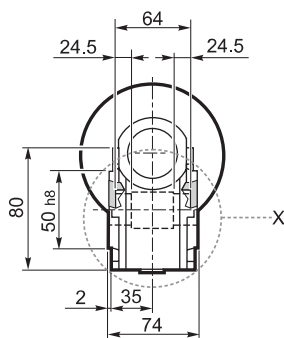

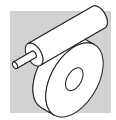

VF 44...P (IEC)

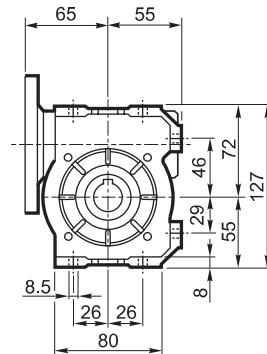
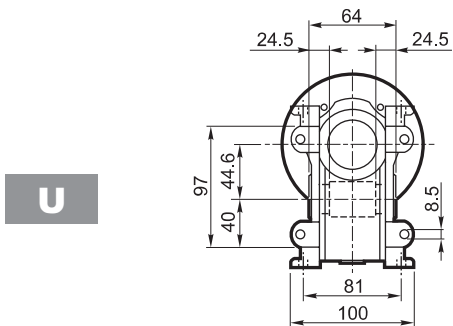
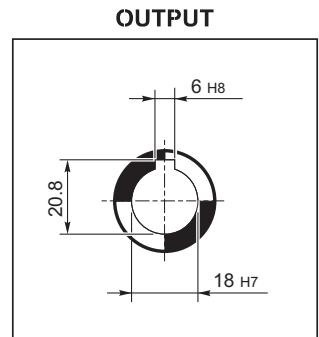
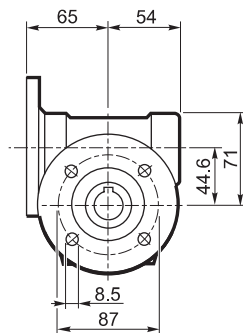
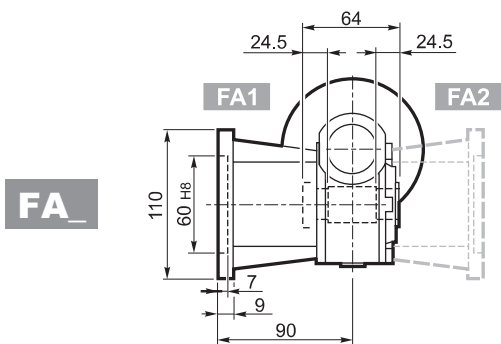
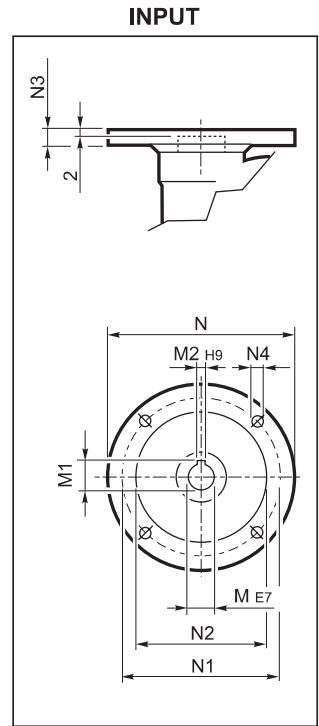
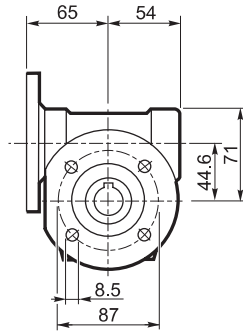
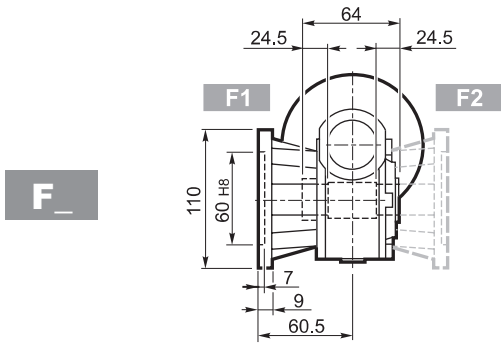

		M	M1	M2	N	N1	N2	N3	N4	
VF 44	P63 B5	11	12.8	4	140	115	95	10	9.5	2.0
VF 44	P71 B5	14	16.3	5	160	130	110	10	9.5	
VF 44	P63 B14	11	12.8	4	90	75	60	8	5.5	
VF 44	P71 B14	14	16.3	5	105	85	70	10	7	

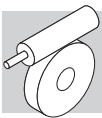

VFR 44...BN 44

A

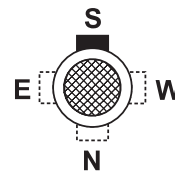
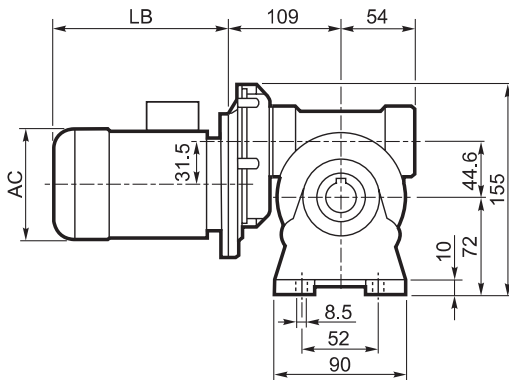
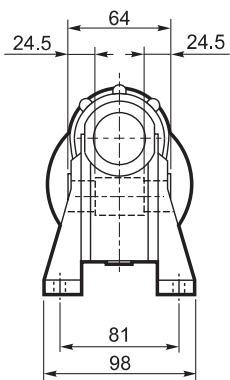

OUTPUT

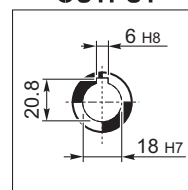

N

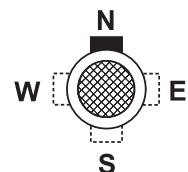
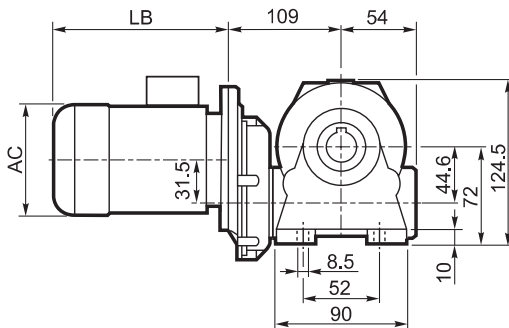
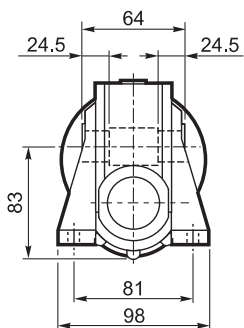

V

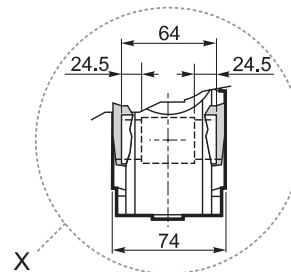
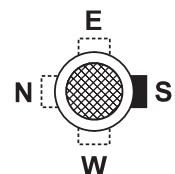
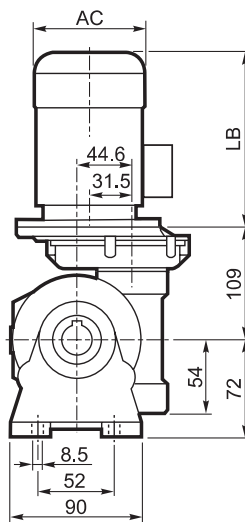
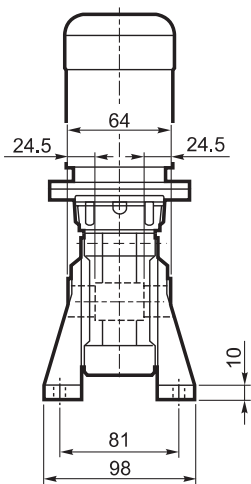

P

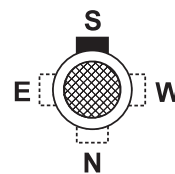
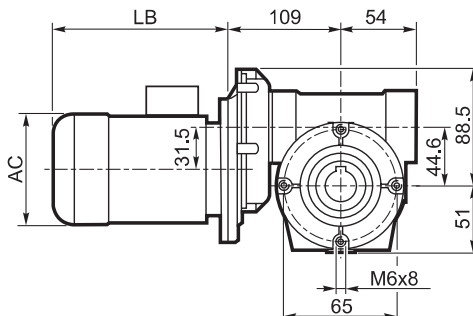
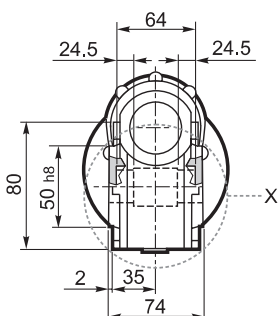

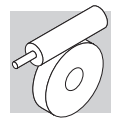

VFR 44...BN 44

F_

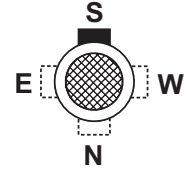
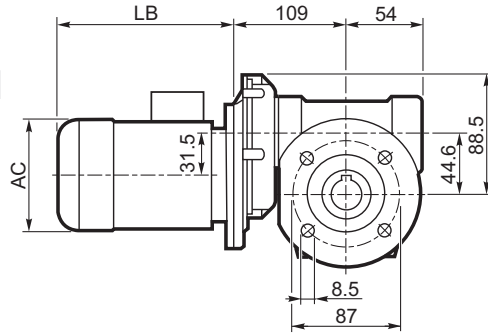
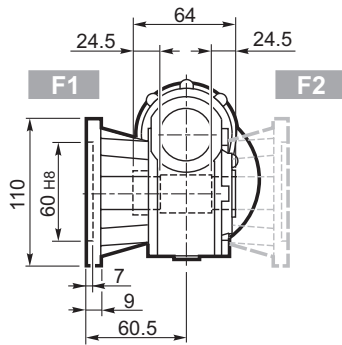

OUTPUT

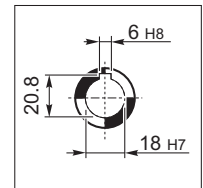

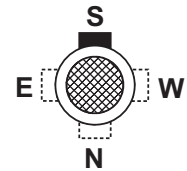
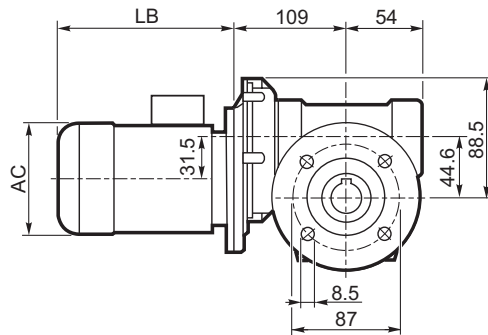
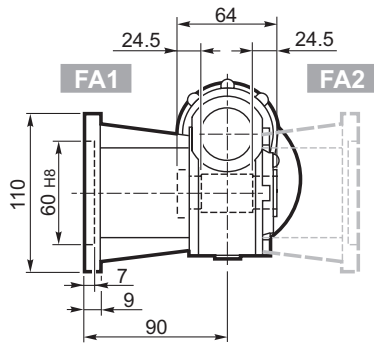

FA_

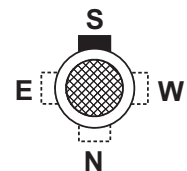
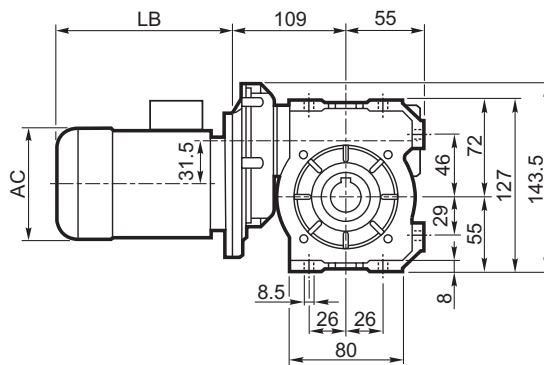
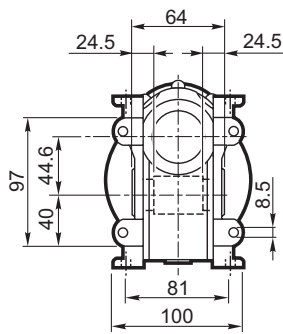

U



	P_n kW	n min ⁻¹	M_n Nm	η %	$\cos\phi$	I_n A (400V)	$\frac{I_s}{I_n}$	$\frac{M_s}{M_n}$	$\frac{M_a}{M_n}$	J_m ($\cdot 10^{-4}$) kgm ²		LB	AC	AD
BN 44B4	0.06	1380	0.42	40	0.58	0.38	2.4	2.3	1.9	1.22	4.7	168	112	94
BN 44C4	0.09	1380	0.63	46	0.65	0.43	2.8	2.3	2	1.49	4.6	168	112	94

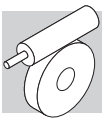

VF/VF 30/44...P (IEC)

A

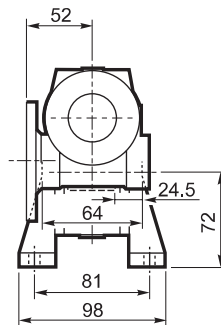
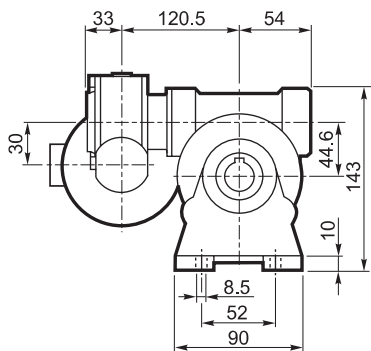

INPUT

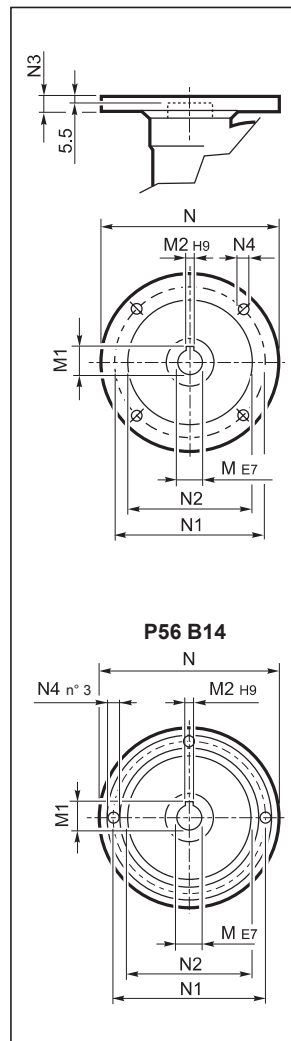

F

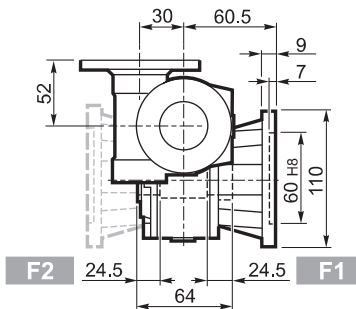
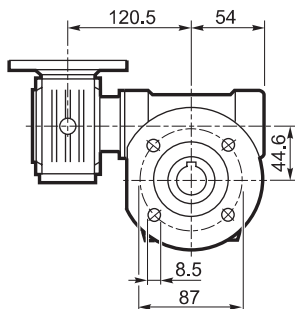

OUTPUT

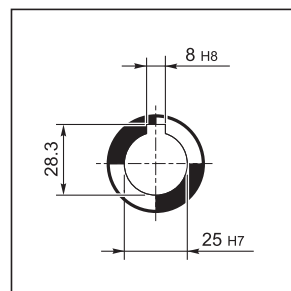

FA

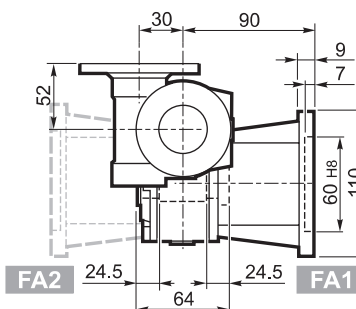
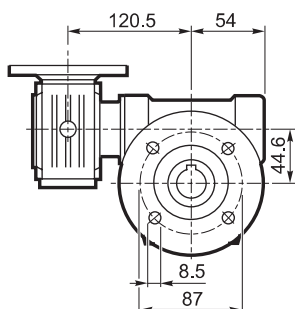

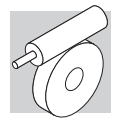

VF/VF 30/44...P (IEC)

P

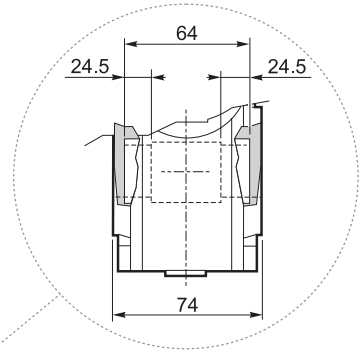
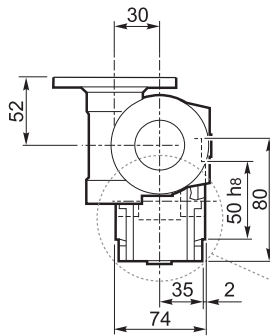
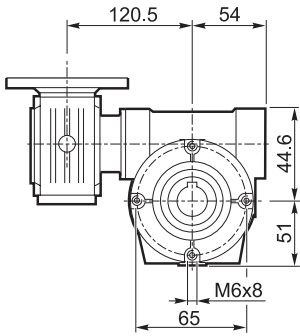

INPUT

U

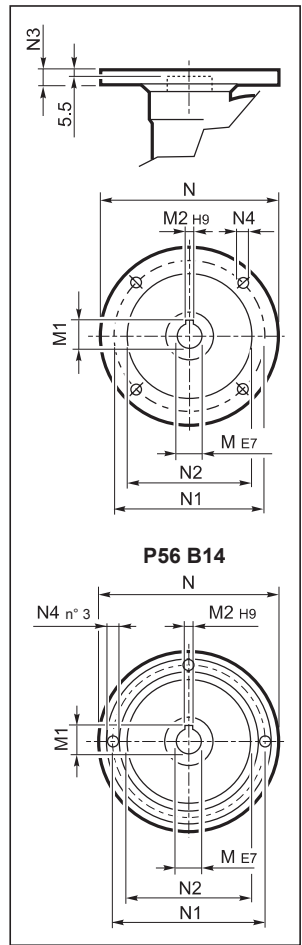
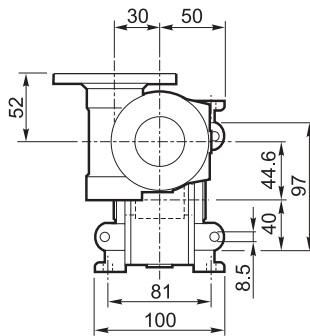
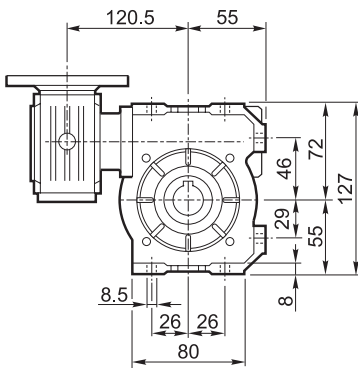

OUTPUT

		M	M1	M2	N	N1	N2	N3	N4	
VF/VF 30/44	P56 B14	9	10.4	3	80	65	50	7	5.5	3.5
VF/VF 30/44	P63 B14	11	12.8	4	90	75	60	6	5.5	

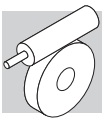

VF 49...P (IEC)

A

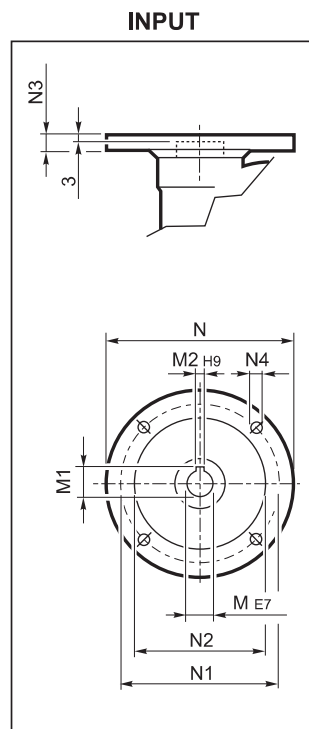
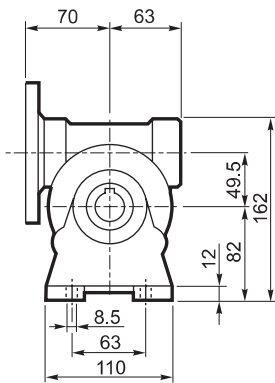
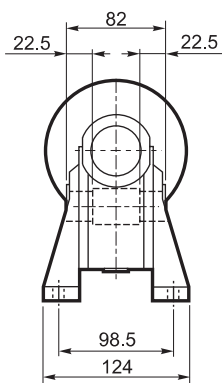

N

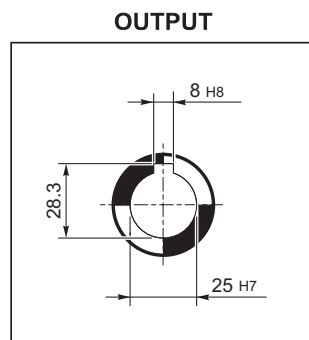
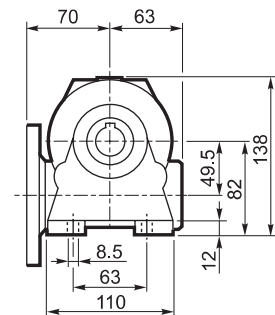
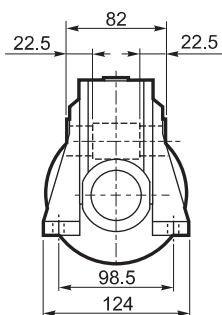

V

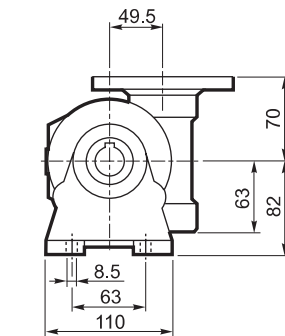
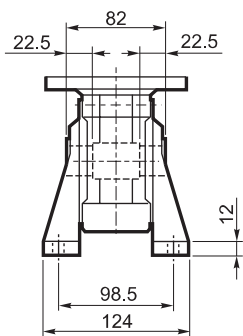

P

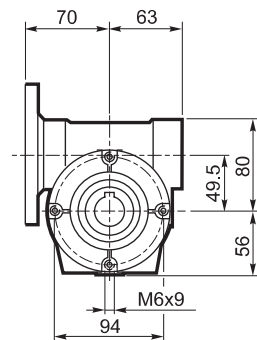
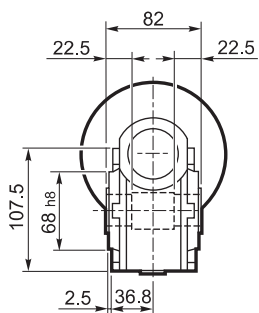

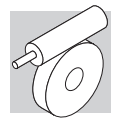

VF 49...P (IEC)

F_

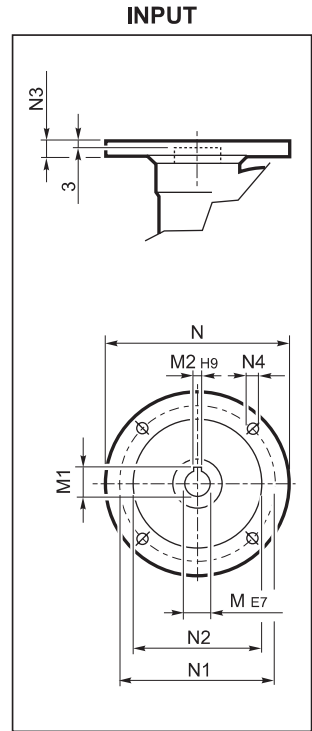
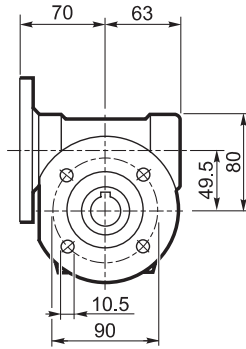
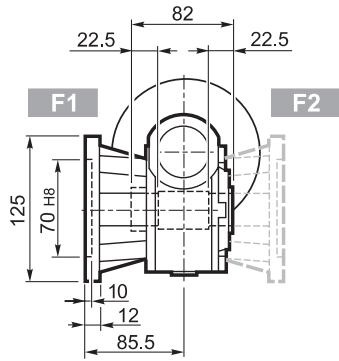

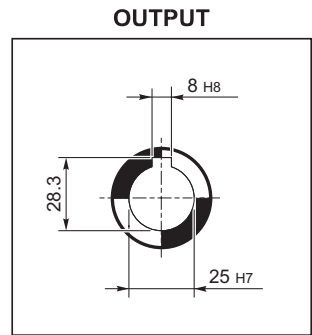
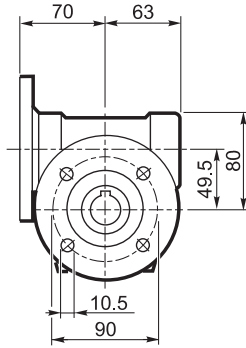
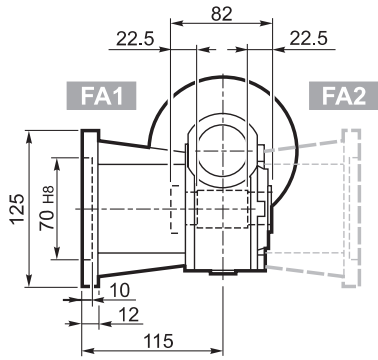

FA_

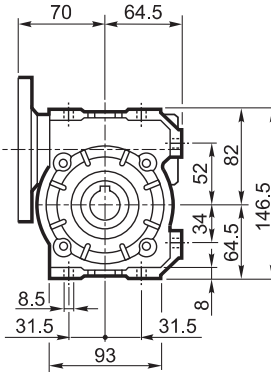
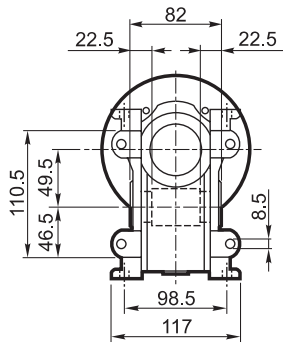

U



		M	M1	M2	N	N1	N2	N3	N4	
VF 49	P63 B5	11	12.8	4	140	115	95	10.5	9.5	3.0
VF 49	P71 B5	14	16.3	5	160	130	110	10.5	9.5	
VF 49	P80 B5	19	21.8	6	200	165	130	10	11.5	
VF 49	P63 B14	11	12.8	4	90	75	60	7	6	
VF 49	P71 B14	14	16.3	5	105	85	70	10.5	6.5	
VF 49	P80 B14	19	21.8	6	120	100	80	10	7	

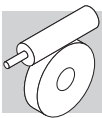

VFR 49...P (IEC)

A

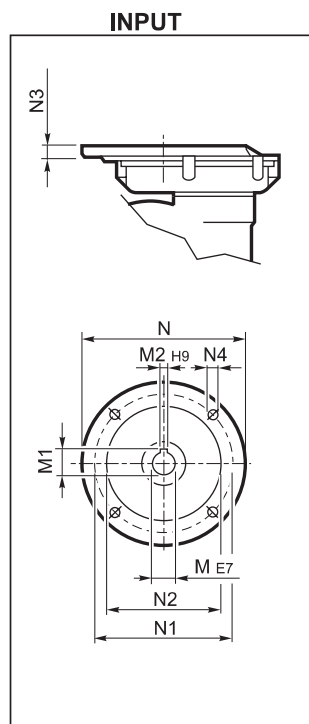
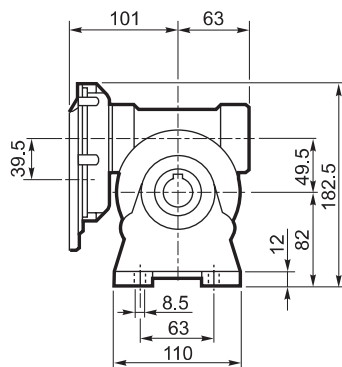
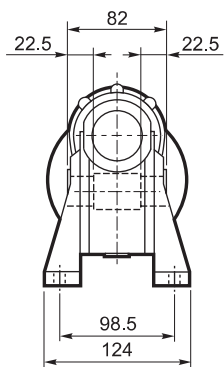

N

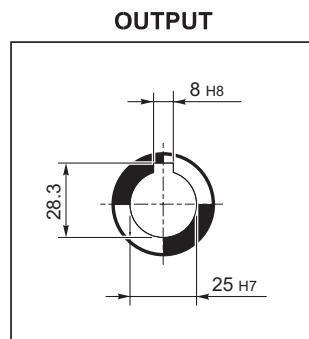
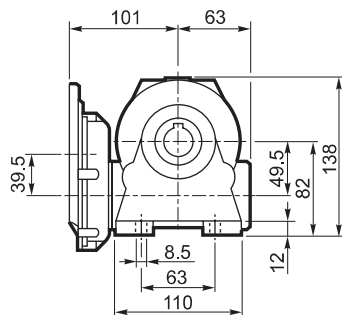
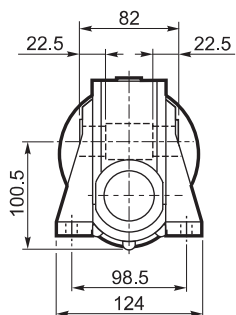

V

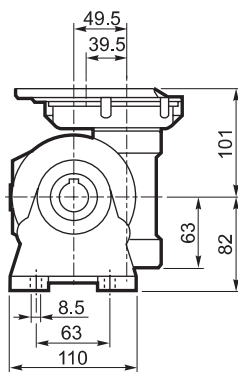
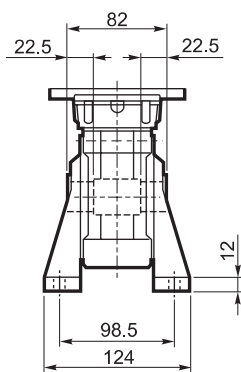

P

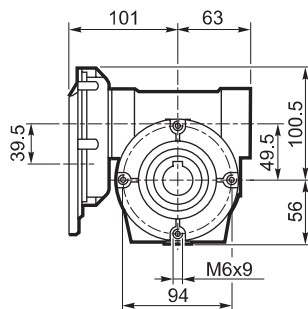
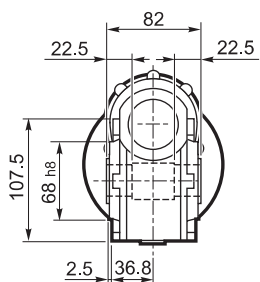

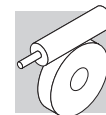

VFR 49...P (IEC)

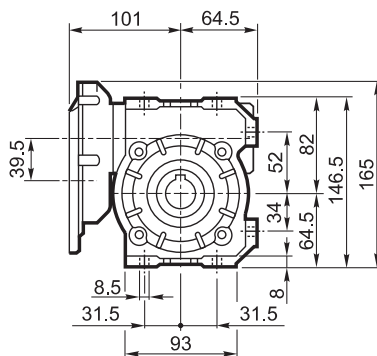
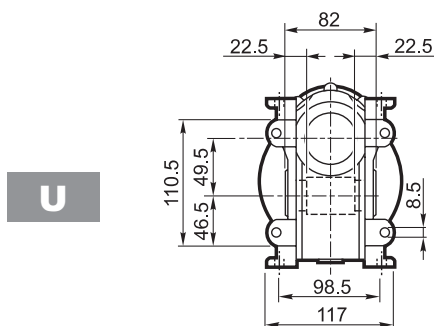
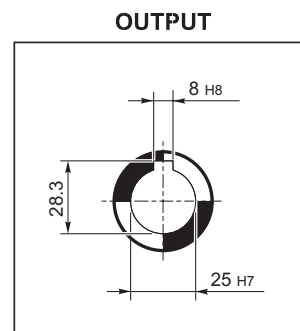
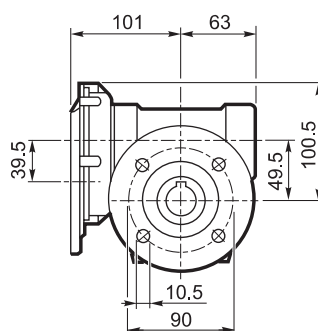
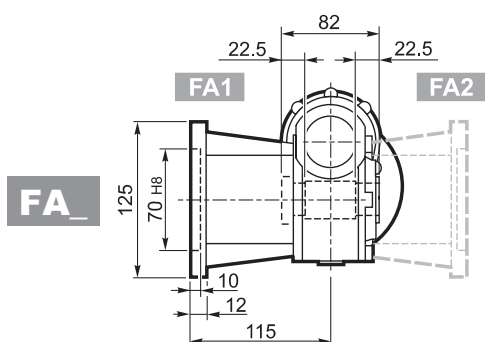
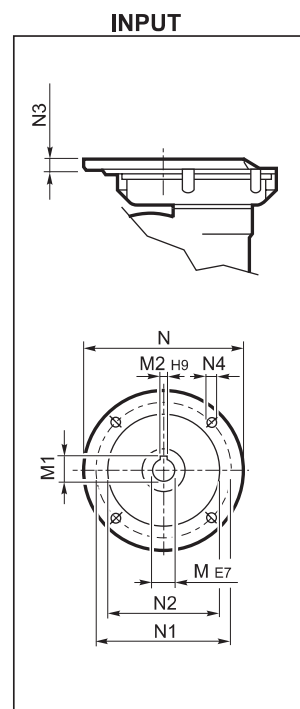
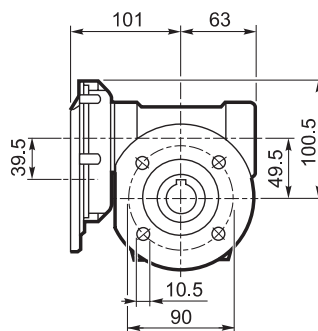
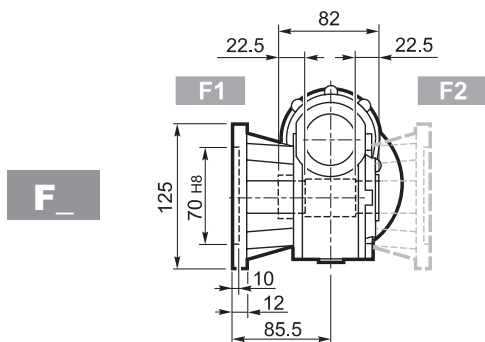

		M	M1	M2	N	N1	N2	N3	N4	
VFR 49	P63 B5	11	12.8	4	140	115	95	11	M8 x 19	5.0

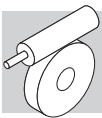

VF/VF 30/49...P (IEC)

A

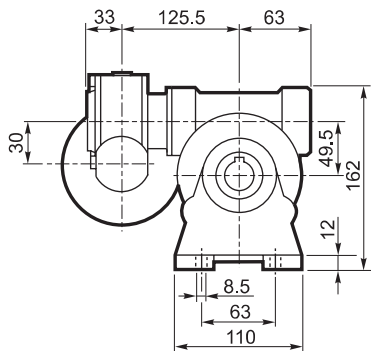

F

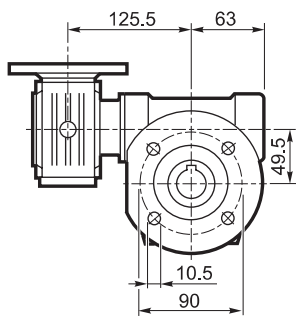

FA

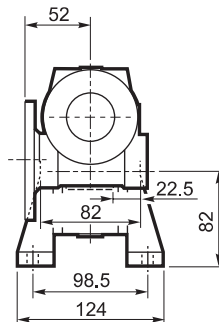
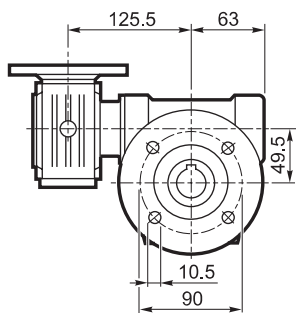

F2 **F1**

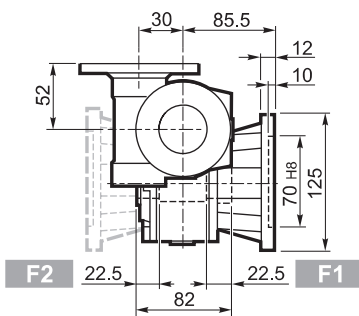

FA2 **FA1**

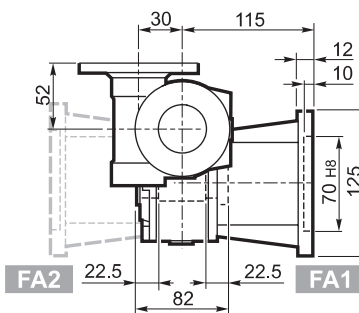

INPUT

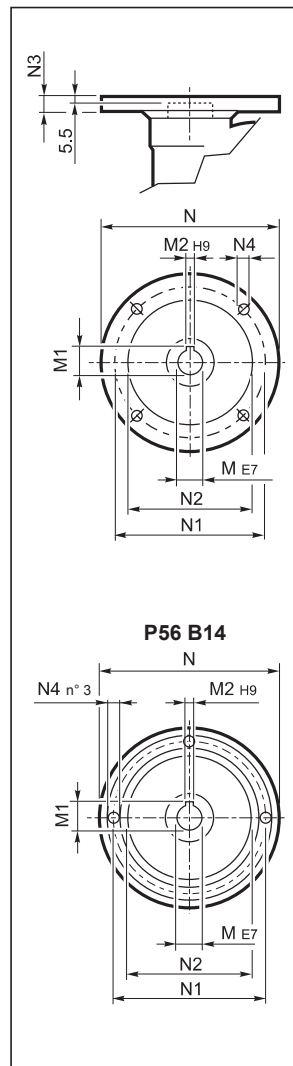

OUTPUT

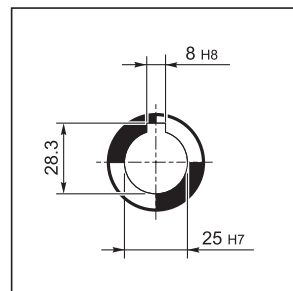

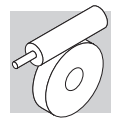

VF/VF 30/49...P (IEC)

P

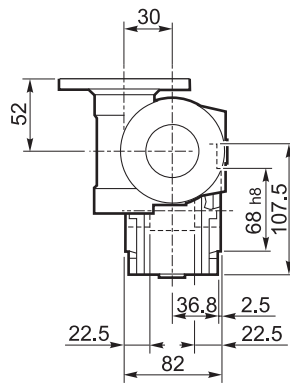
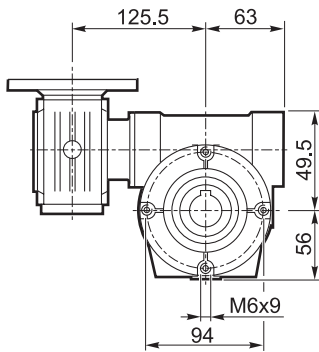

INPUT

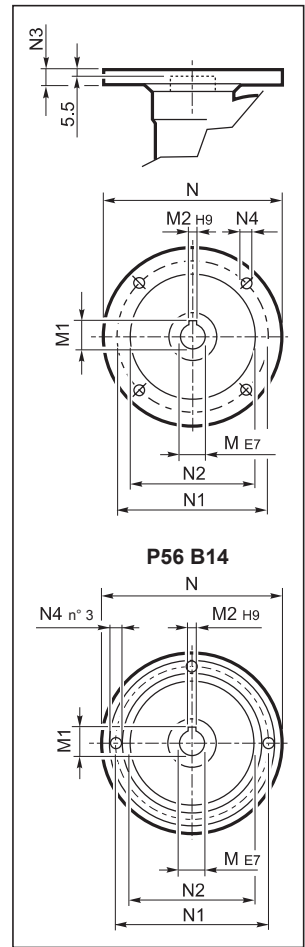

U

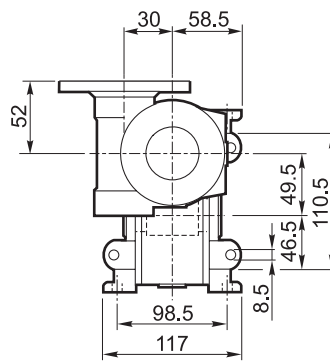
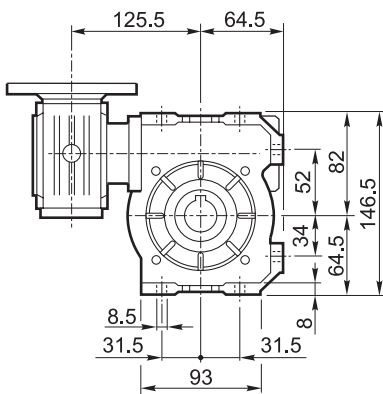

OUTPUT

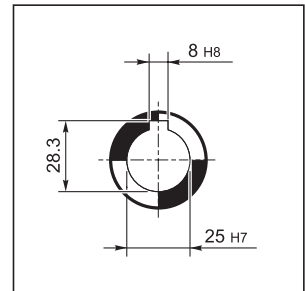

		M	M1	M2	N	N1	N2	N3	N4	
VF/VF 30/49	P56 B14	9	10.4	3	80	65	50	7	5.5	4.5
VF/VF 30/49	P63 B14	11	12.8	4	90	75	60	6	5.5	

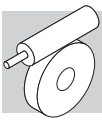

W 63...M

U

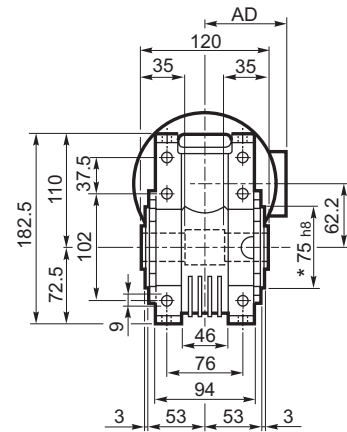
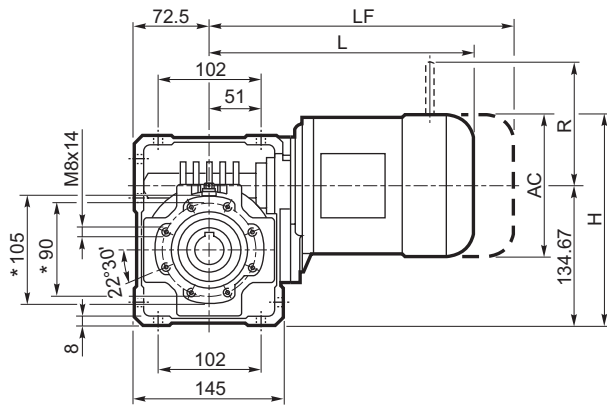

UF_

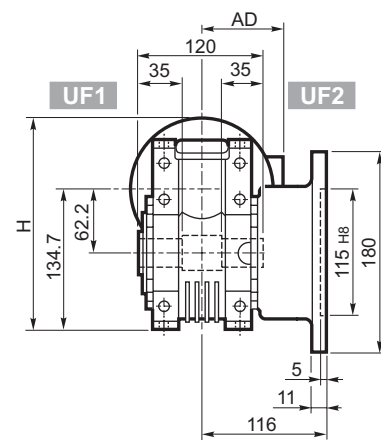
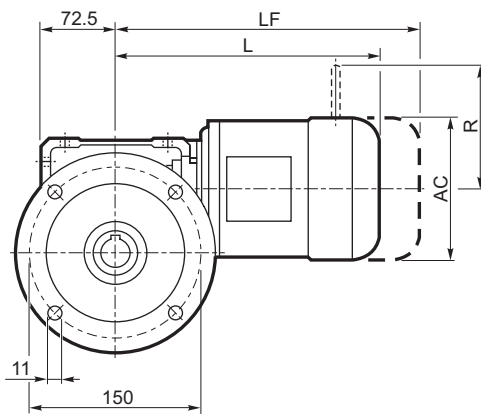

UFC_

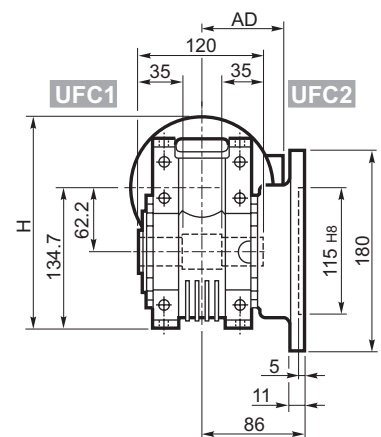
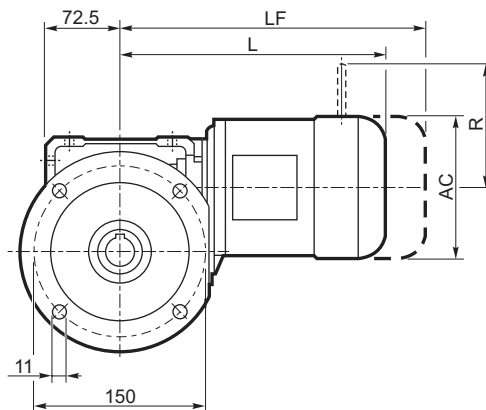

OUTPUT

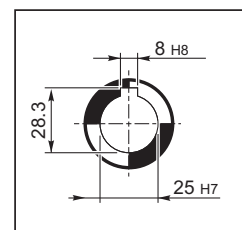

			M_				Kg	M...FD M...FA		M...FD		M...FA	
			AC	H	L	AD		LF	Kg	R	AD	R	AD
W 63	S1	M1	138	204	289	108	13	350	15	103	135	124	108
W 63	S2	M2S	156	213	317	119	17	393	20	129	146	134	119

* Tous le deux cotés

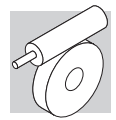

W 63...P (IEC)

U

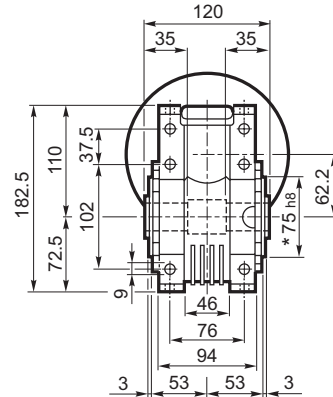
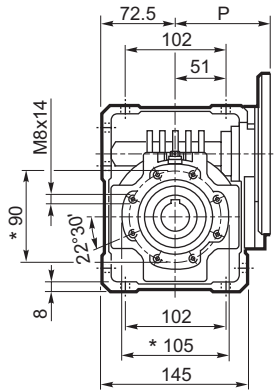

INPUT

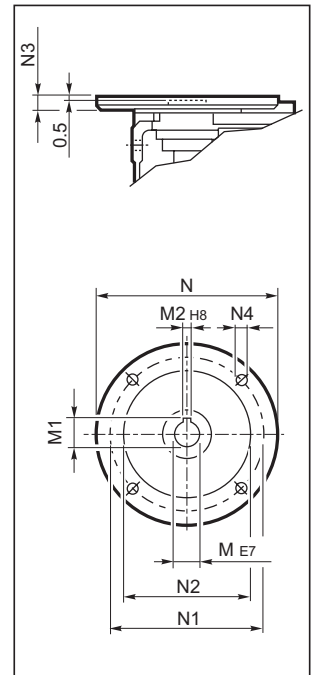

UF_

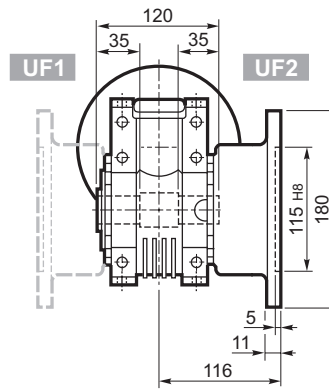
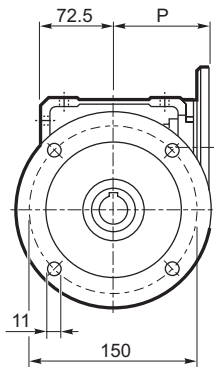

OUTPUT

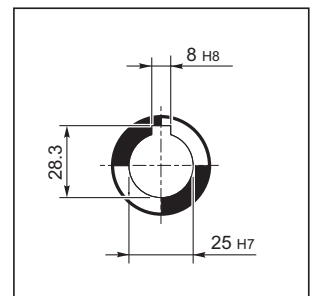

UFC_

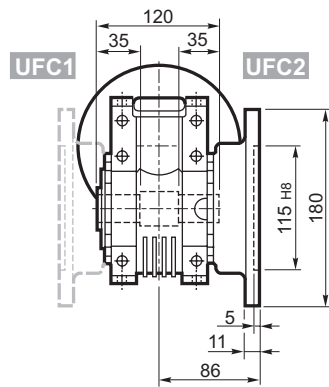
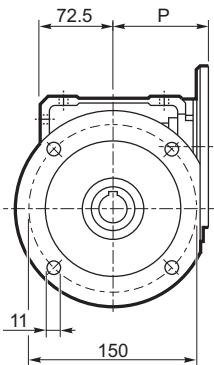

		M	M1	M2	N	N1	N2	N3	N4	P	
W 63	P71 B5	14	16.3	5	160	130	110	11	9	95	6.3
W 63	P80 B5	19	21.8	6	200	165	130	12	11.5	102	6.5
W 63	P90 B5	24	27.3	8	200	165	130	12	11.5	102	6.4
W 63	P71 B14	14	16.3	5	105	85	70	11	6.5	95	6.1
W 63	P80 B14	19	21.8	6	120	100	80	11	6.5	102	6.3
W 63	P90 B14	24	27.3	8	140	115	95	11	8.5	102	6.3

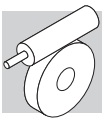

WR 63...P (IEC)

U

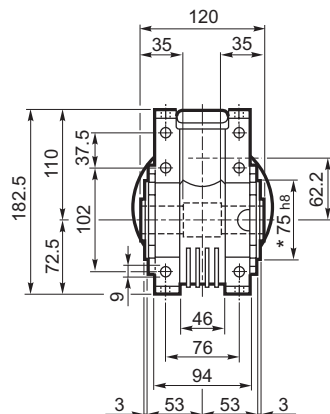
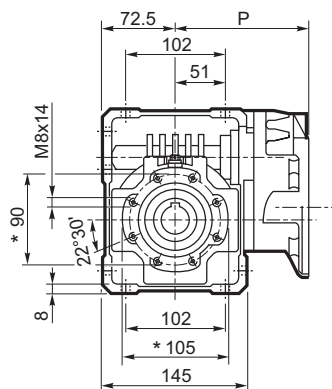

INPUT

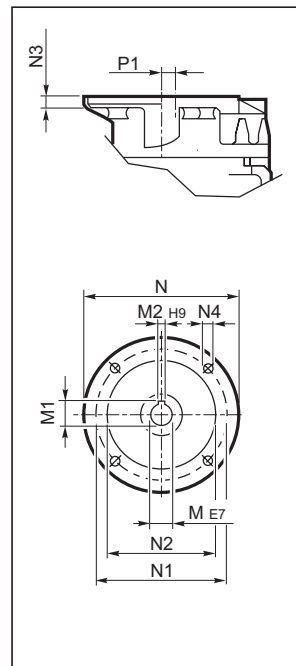

UF_

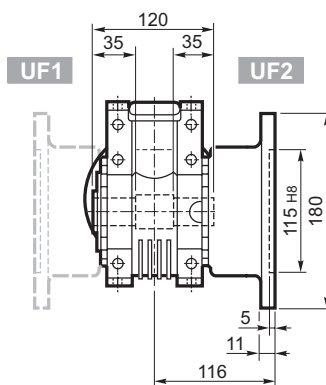
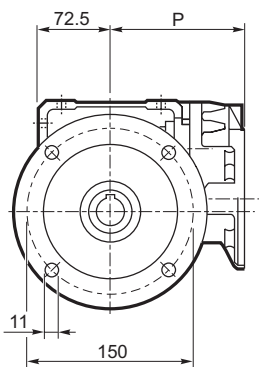

OUTPUT

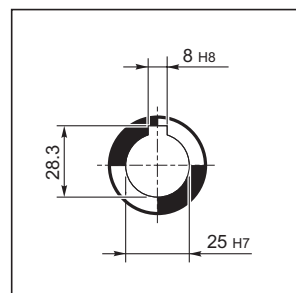

UFC_

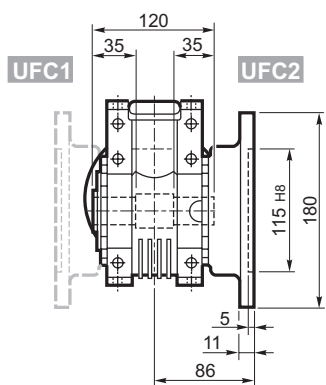
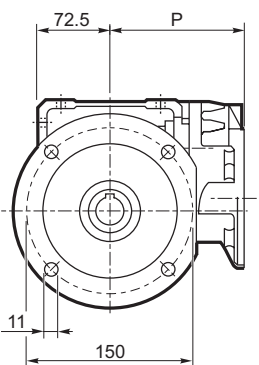

		M	M1	M2	N	N1	N2	N3	N4	P	P1	
WR 63	P63 B5	11	12.8	4	140	115	95	10	M8x10	133.5	11.42	7.1
WR 63	P71 B5	14	16.3	5	160	130	110	10	M8x10	133.5	11.42	

* Tous le deux cotés

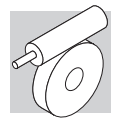

VF/W 30/63...P (IEC)

U

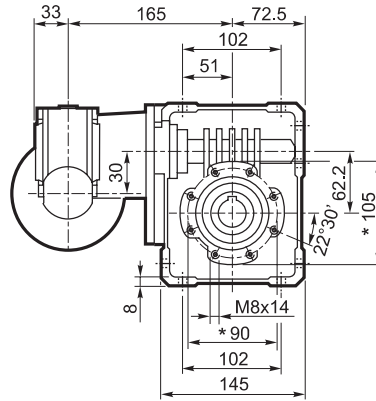
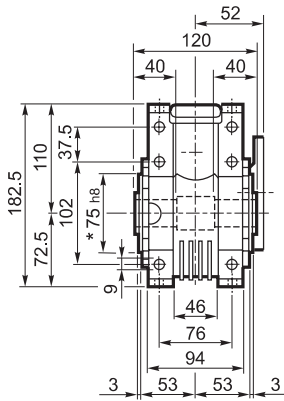

UF

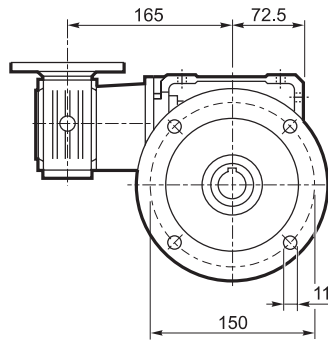
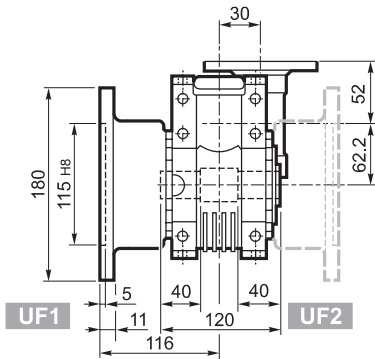

UFC

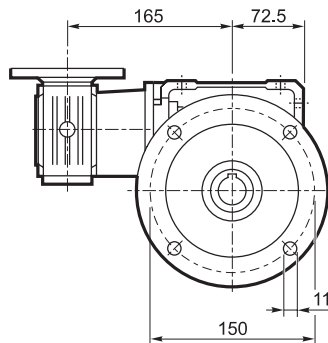
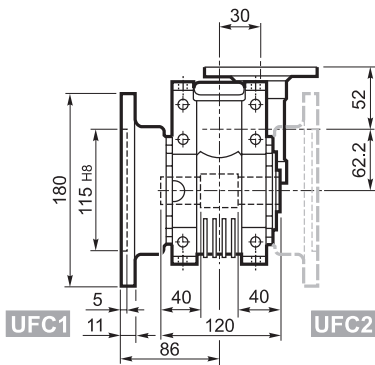

INPUT

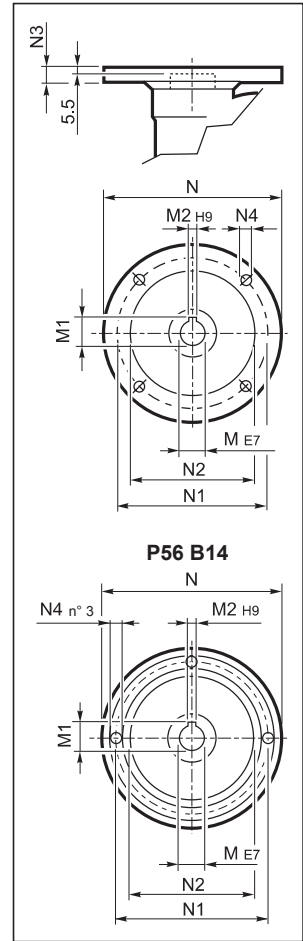

OUTPUT

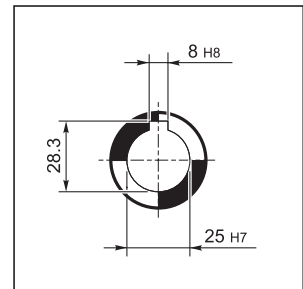

		M	M1	M2	N	N1	N2	N3	N4	Kg
VF/W 30/63	P56 B5	9	10.4	3	120	100	80	7	7	8.0
VF/W 30/63	P63 B5	11	12.8	4	140	115	95	8	9.5	
VF/W 30/63	P56 B14	9	10.4	3	80	65	50	7	5.5	
VF/W 30/63	P63 B14	11	12.8	4	90	75	60	6	5.5	

* Tous le deux cotés

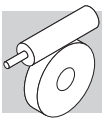

W 75...M

U

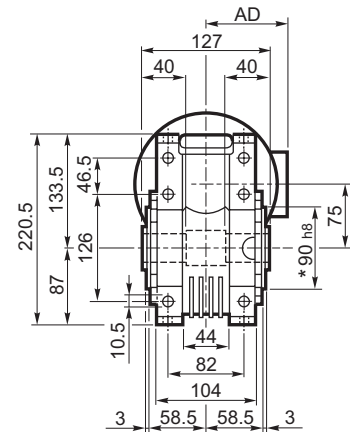
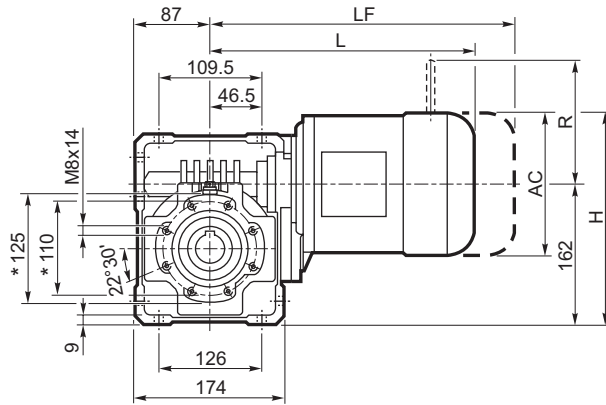

UF_

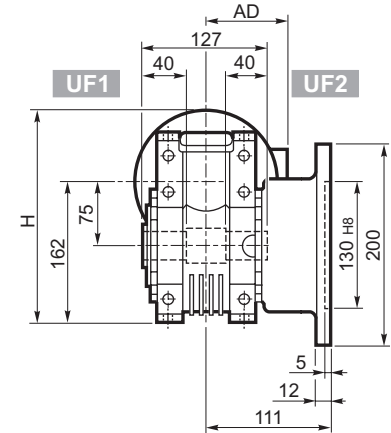
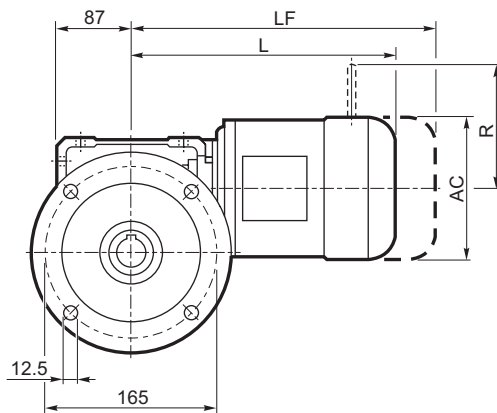

UFC_

UFCR_#

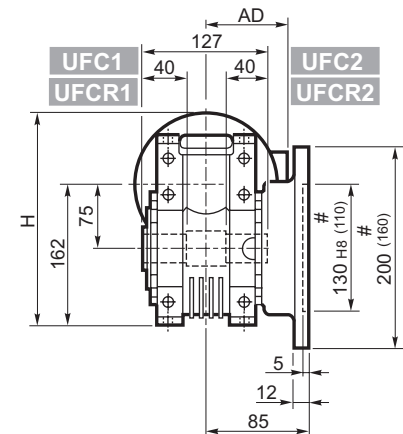
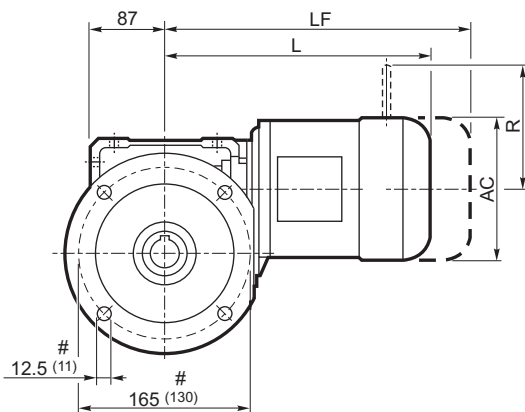

STANDARD OUTPUT

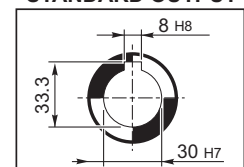

ON REQUEST OUTPUT

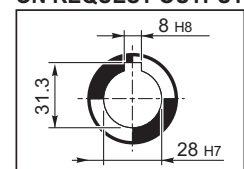

Icon	S	M	M_				Kg	M...FD M...FA		Kg	M...FD		M...FA	
			AC	H	L	AD		LF	R		AD	R	AD	
	W 75	S1	M1	138	231	308	108	16.0	369	18.2	103	135	124	108
	W 75	S2	M2S	153	240	333	119	18.5	409	21.6	129	146	134	119
	W 75	S3	M3S	193	258.5	376	142	25.6	472	31	160	158	160	142
	W 75	S3	M3L	193	258.5	408	142	28.6	499	34	160	158	160	142

* Tous le deux cotés

Bride reduit

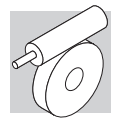

W 75...P (IEC)

U

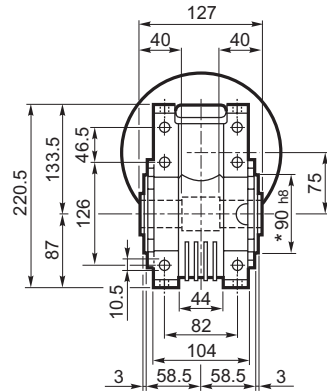
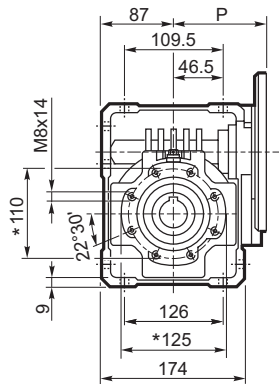

INPUT

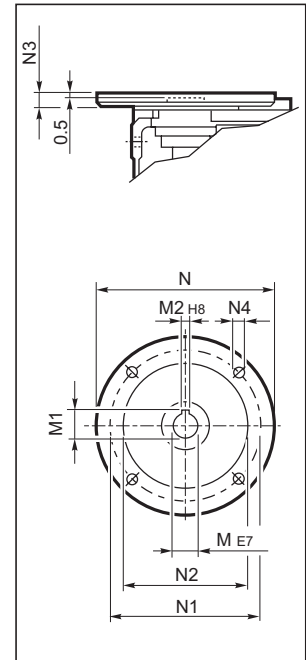

UF_

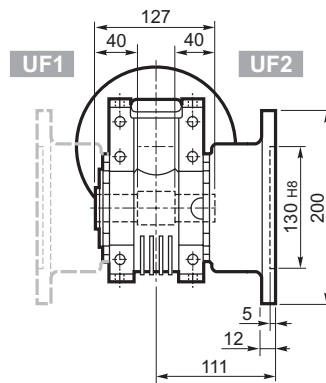
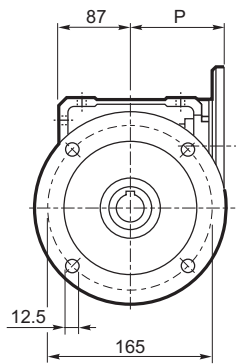

STANDARD OUTPUT

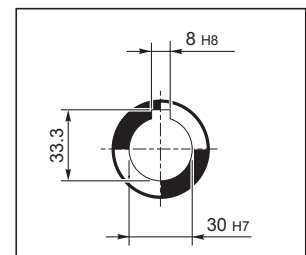

UFC_

UFCR_#

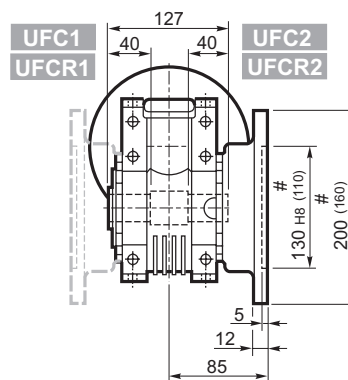
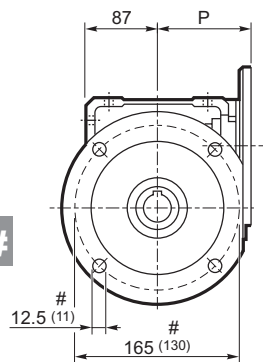

ON REQUEST OUTPUT

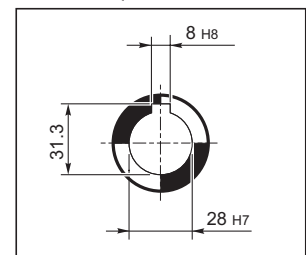

		M	M1	M2	N	N1	N2	N3	N4	P	
W 75	P71 B5	14	16.3	5	160	130	110	11	9	112	9.5
W 75	P80 B5	19	21.8	6	200	165	130	12	11.5	112	9.7
W 75	P90 B5	24	27.3	8	200	165	130	12	11.5	112	9.6
W 75	P100 B5	28	31.3	8	250	215	180	13	12.5	120	9.7
W 75	P112 B5	28	31.3	8	250	215	180	13	12.5	120	9.7
W 75	P80 B14	19	21.8	6	120	100	80	7.5	6.5	112	9.4
W 75	P90 B14	24	27.3	8	140	115	95	7.5	8.5	112	9.4
W 75	P100 B14	28	31.3	8	160	130	110	10	8.5	120	9.5
W 75	P112 B14	28	31.3	8	160	130	110	10	8.5	120	9.5

* Tous le deux cotés

Bride reduit

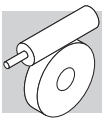

WR 75...P (IEC)

U

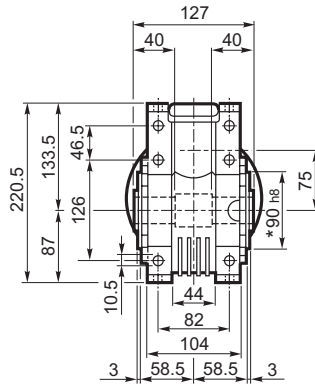
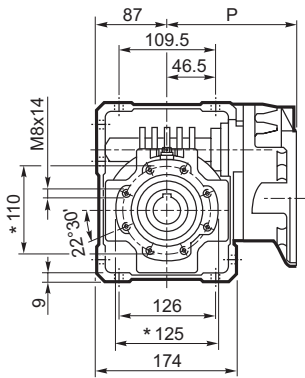

INPUT

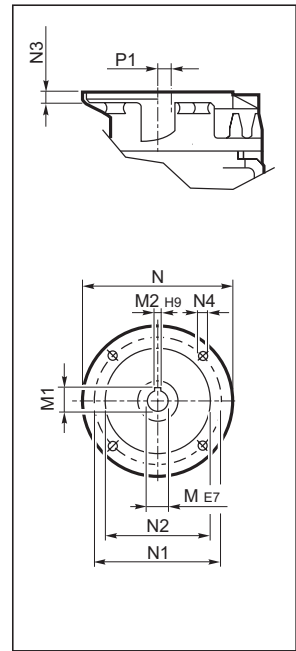

UF_

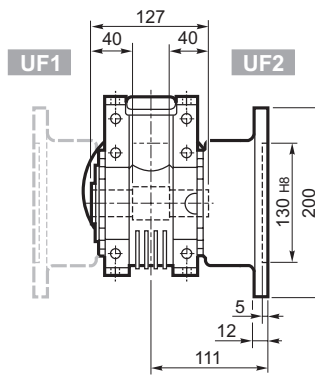
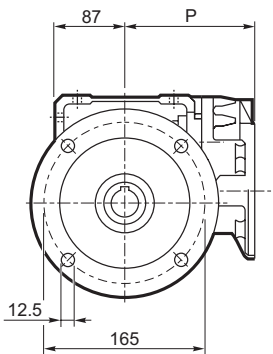

STANDARD OUTPUT

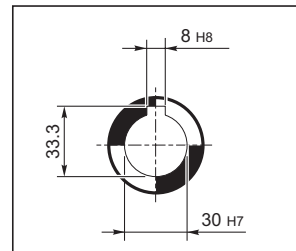

UFC_

UFCR_#

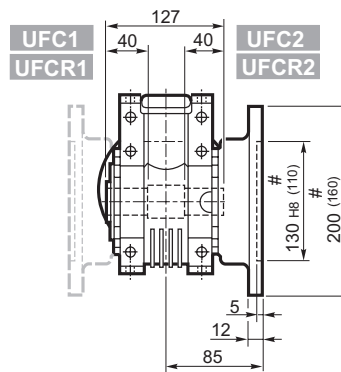
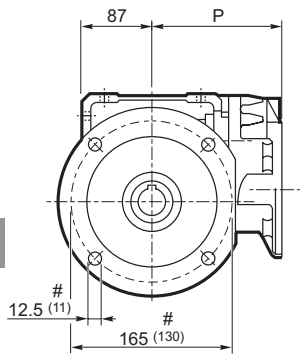

ON REQUEST OUTPUT

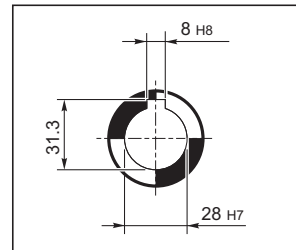

		M	M1	M2	N	N1	N2	N3	N4	P	P1	
WR 75	P63 B5	11	12.8	4	140	115	95	10	M8x10	152	23.53	10.6
WR 75	P71 B5	14	16.3	5	160	130	110	10	M8x10	152	23.53	10.7
WR 75	P80 B5	19	21.8	6	200	165	130	12	M10x13	163.5	11	11.5
WR 75	P90 B5	24	27.3	8	200	165	130	12	M10x13	163.5	11	11.6

* Tous le deux cotés

Bride reduit

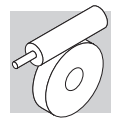

VF/W 44/75...P (IEC)

U

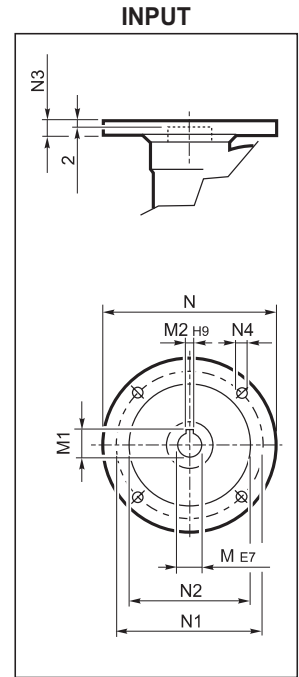
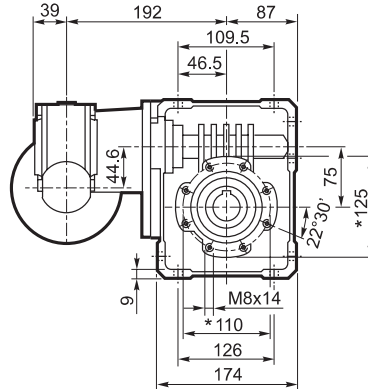
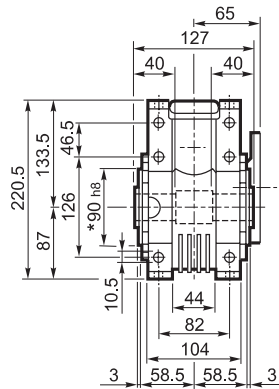

UF_

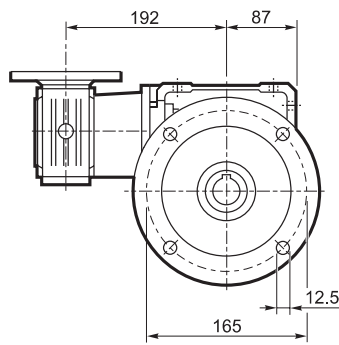
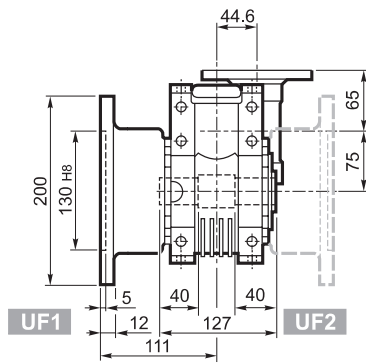

STANDARD OUTPUT

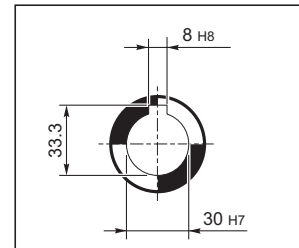

UFC_

UFCR_#

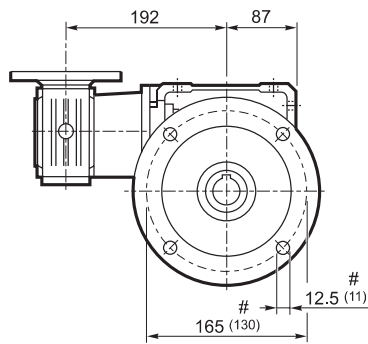
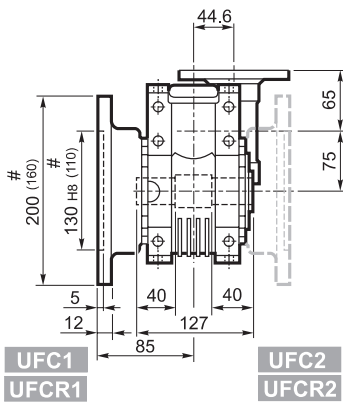

ON REQUEST OUTPUT

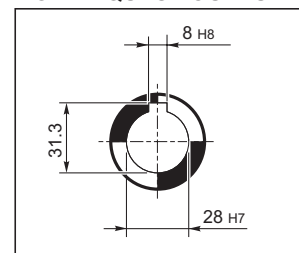

		M	M1	M2	N	N1	N2	N3	N4	Kg
										12.5
VF/W 44/75	P63 B5	11	12.8	4	140	115	95	10	9.5	
VF/W 44/75	P71 B5	14	16.3	5	160	130	110	10	9.5	
VF/W 44/75	P63 B14	11	12.8	4	90	75	60	8	5.5	
VF/W 44/75	P71 B14	14	16.3	5	105	85	70	10	7	

* Tous le deux cotés

Bride reduit

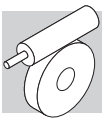

W 86...M

U

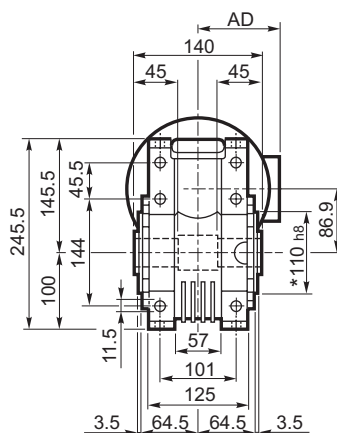
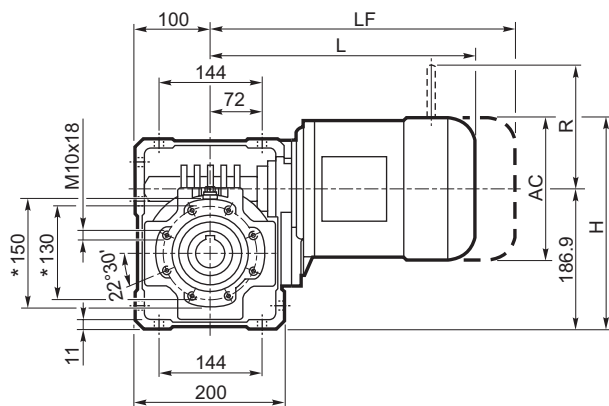

UF

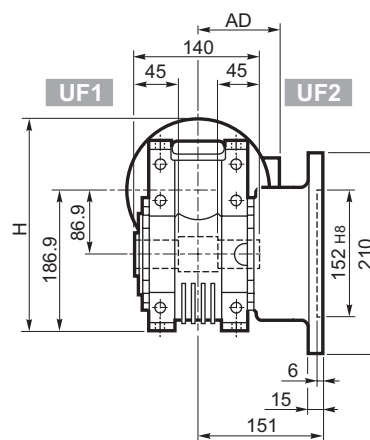
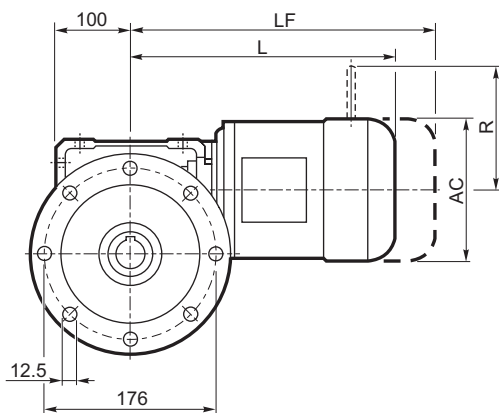

UFC

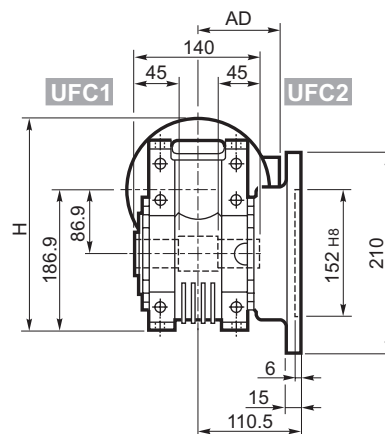
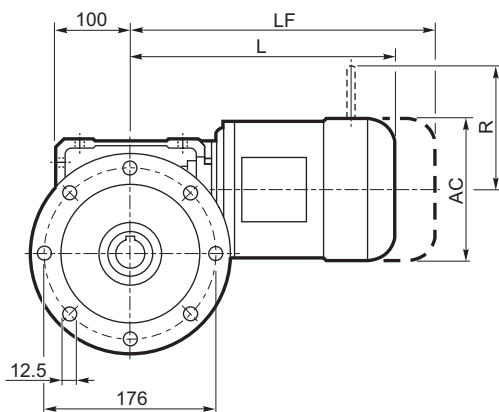

Icon	M ₋							M...FD M...FA		M...FD		M...FA	
	AC	H	L	AD	Kg	LF	Kg	R	AD	R	AD		
	138	256	324	108	20.1	385	22.3	103	135	124	108		
	156	265	349	119	22.6	425	25.7	129	146	134	119		
	193	283.5	392	142	29.7	488	35	160	158	160	142		
	193	283.5	424	142	33	515	36	160	158	160	142		

OUTPUT

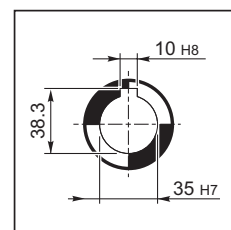

* Tous le deux cotés

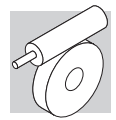

W 86...P (IEC)

U

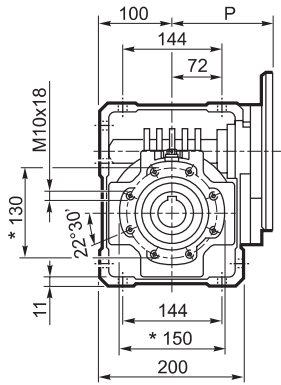

UF

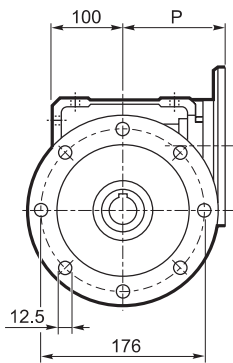

UFC

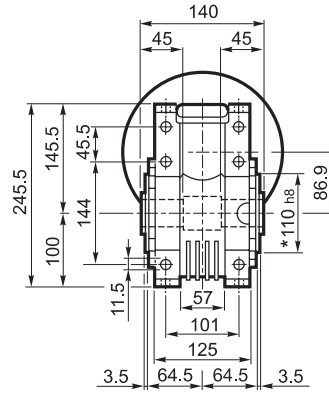
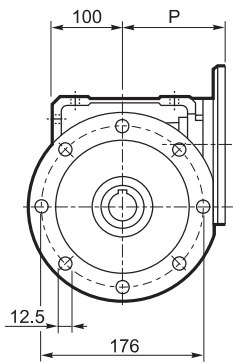

UF1

UF2

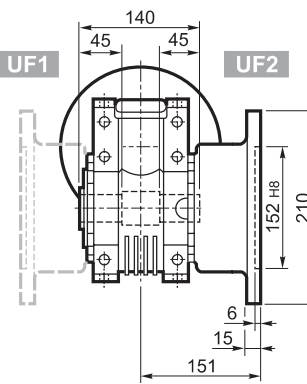

UFC1

UFC2

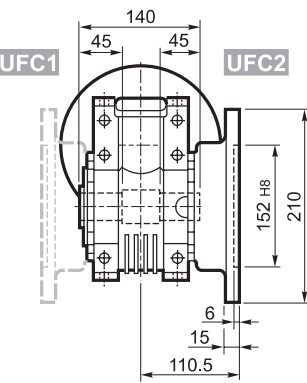

INPUT

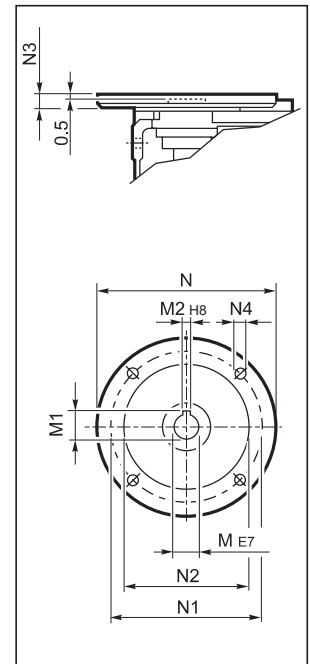

OUTPUT

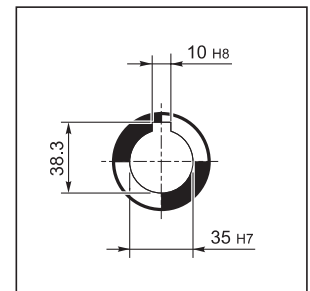

		M	M1	M2	N	N1	N2	N3	N4	P	
W 86	P71 B5	14	16.3	5	160	130	110	11	9	128	13.6
W 86	P80 B5	19	21.8	6	200	165	130	12	11.5	128	13.8
W 86	P90 B5	24	27.3	8	200	165	130	12	11.5	128	13.7
W 86	P100 B5	28	31.3	8	250	215	180	13	12.5	136	13.8
W 86	P112 B5	28	31.3	8	250	215	180	13	12.5	136	13.8
W 86	P80 B14	19	21.8	6	120	100	80	7.5	6.5	128	13.5
W 86	P90 B14	24	27.3	8	140	115	95	7.5	8.5	128	13.5
W 86	P100 B14	28	31.3	8	160	130	110	10	8.5	136	13.6
W 86	P112 B14	28	31.3	8	160	130	110	10	8.5	136	13.6

* Tous le deux cotés

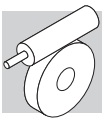

WR 86...P (IEC)

U

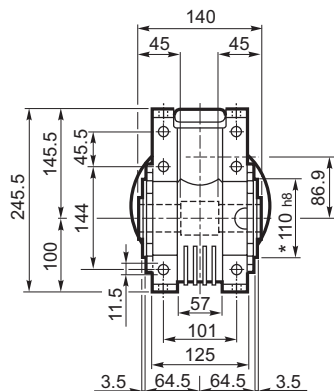
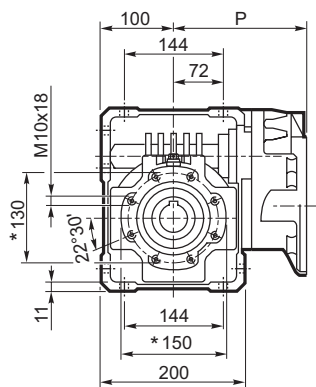

INPUT

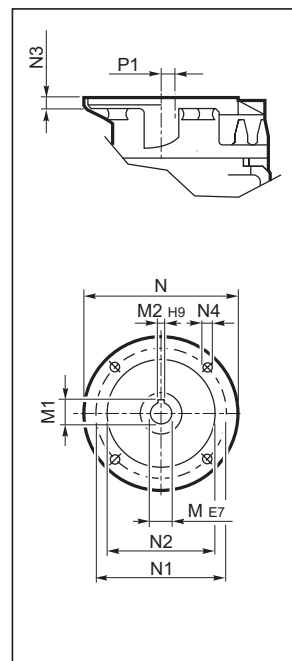

UF

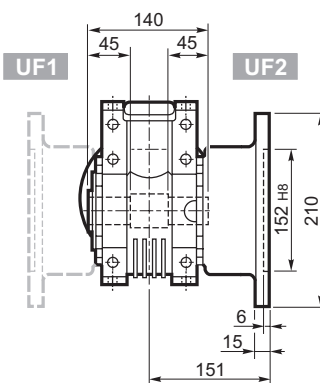
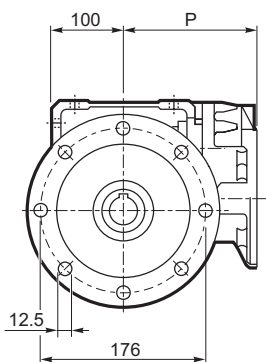

OUTPUT

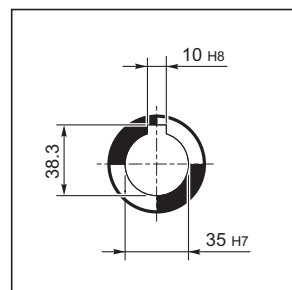

UFC

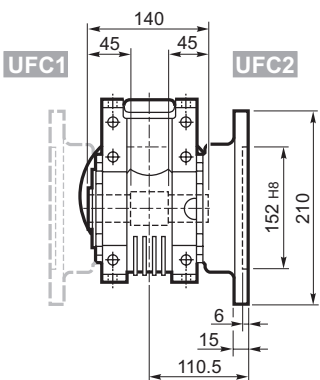
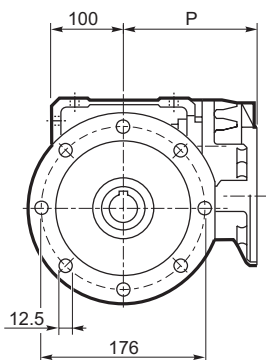

		M	M1	M2	N	N1	N2	N3	N4	P	P1	
WR 86	P63 B5	11	12.8	4	140	115	95	10	M8x10	168	35.4	14.3
WR 86	P71 B5	14	16.3	5	160	130	110	10	M8x10	168	35.4	14.4
WR 86	P80 B5	19	21.8	6	200	165	130	12	M10x13	179.5	22.9	15.2
WR 86	P90 B5	24	27.3	8	200	165	130	12	M10x13	179.5	22.9	15.3

* Tous le deux cotés

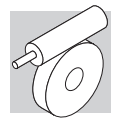

VF/W 44/86... P (IEC)

U

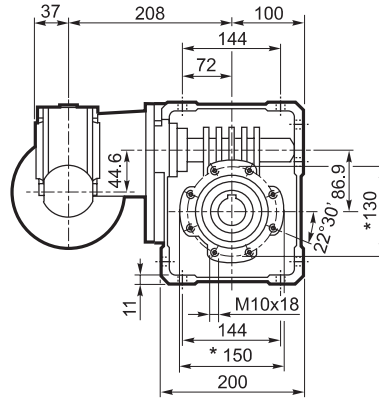
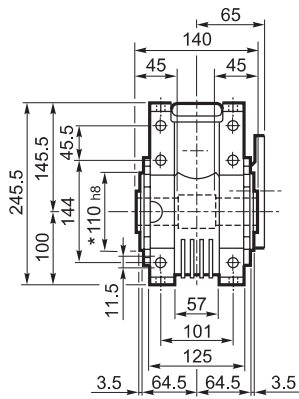

INPUT

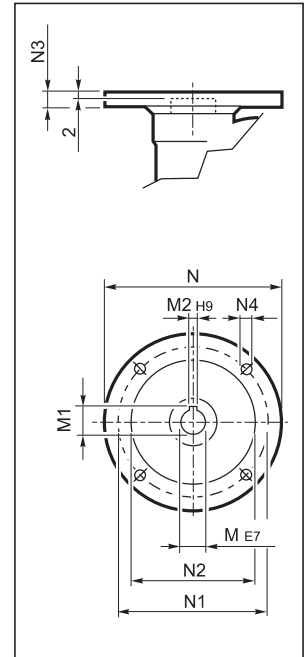

UF_

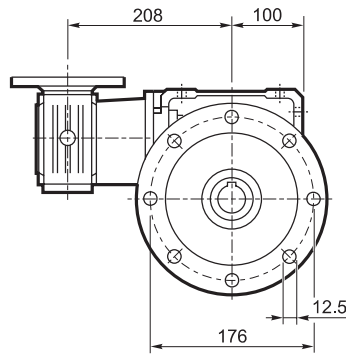
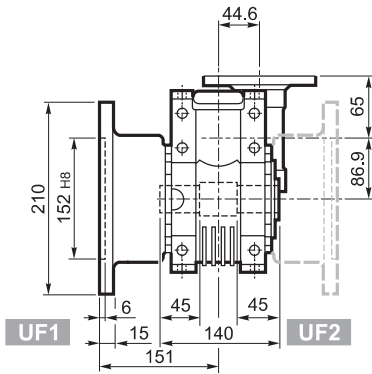

OUTPUT

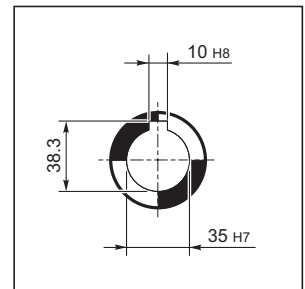

UFC_

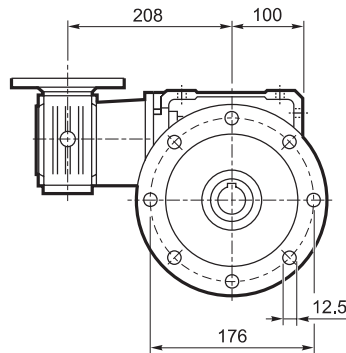
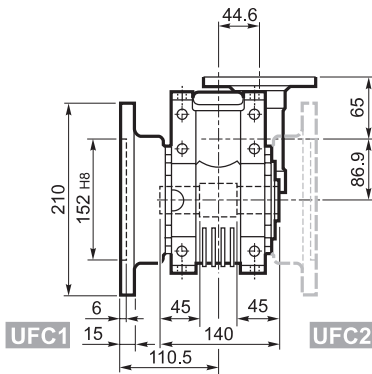

		M	M1	M2	N	N1	N2	N3	N4	
VF/W 44/86	P63 B5	11	12.8	4	140	115	95	10	9.5	16.6
VF/W 44/86	P71 B5	14	16.3	5	160	130	110	10	9.5	
VF/W 44/86	P63 B14	11	12.8	4	90	75	60	8	5.5	
VF/W 44/86	P71 B14	14	16.3	5	105	85	70	10	7	

* Tous le deux cotés

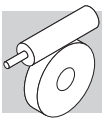

W 110...M

U

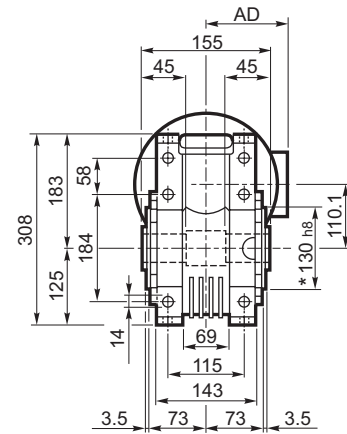
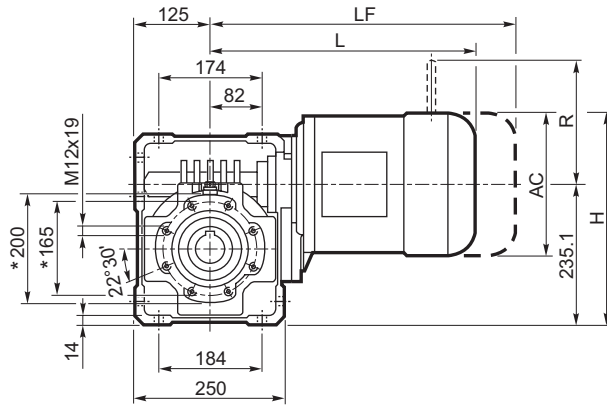

UF_

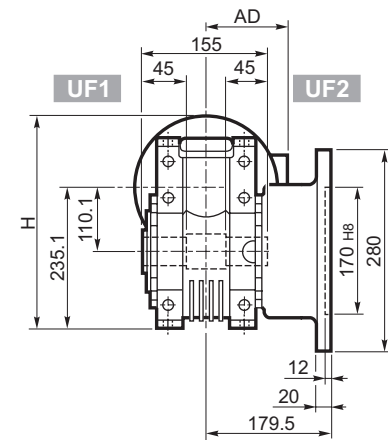
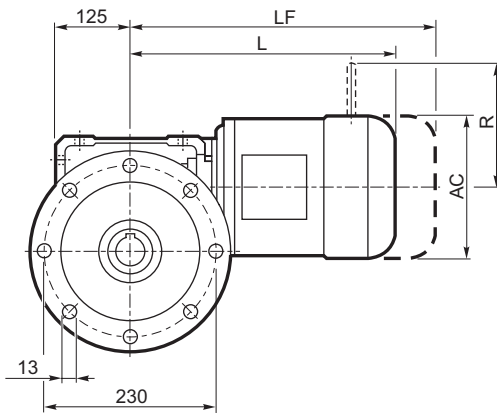

UFC_

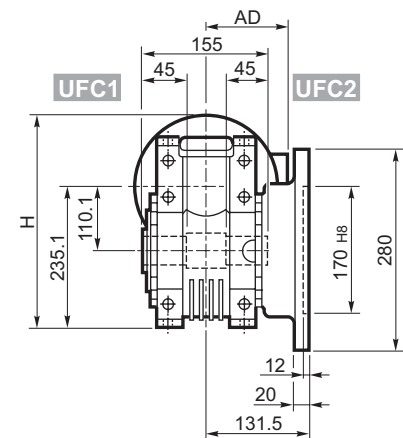
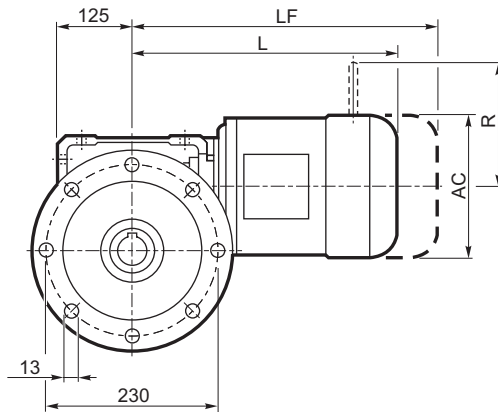

OUTPUT

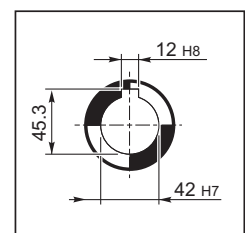

			M_				Kg	M...FD M...FA		Kg	M...FD		M...FA			
			AC	H	L	AD		LF	R		AD	R	AD			
			W 110	S2	M2S	156	313	364	119	38	440	41	129	146	134	119
W 110	S3	M3S	193	332	407	142	46	503	50	160	158	160	142			
W 110	S3	M3L	193	332	439	142	48	530	53	160	158	160	142			

* Tous le deux cotés

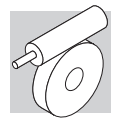

W 110...P (IEC)

U

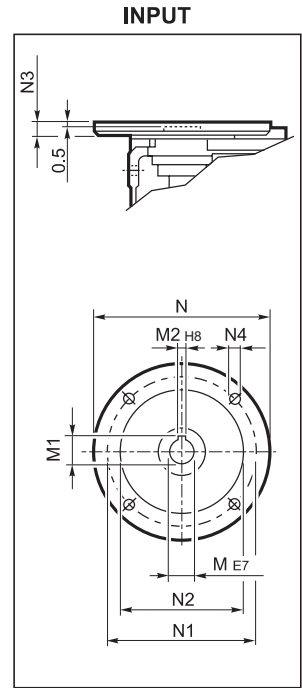
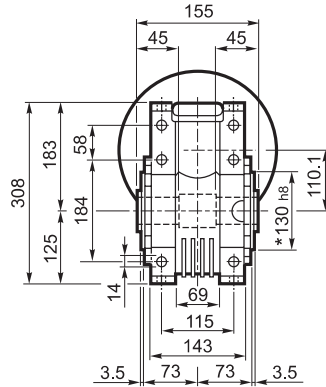
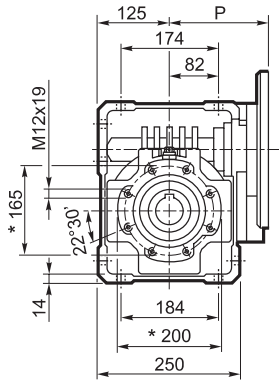

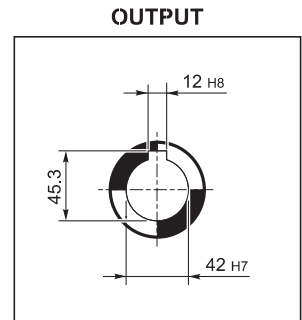
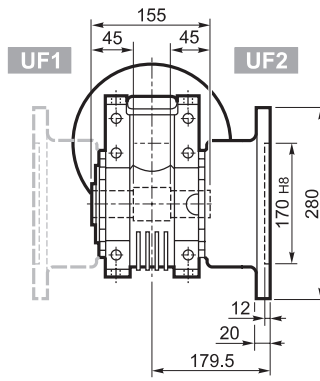
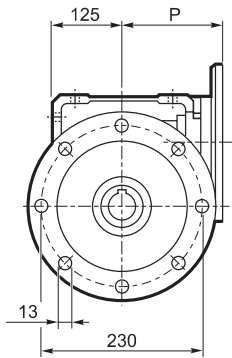

UF_

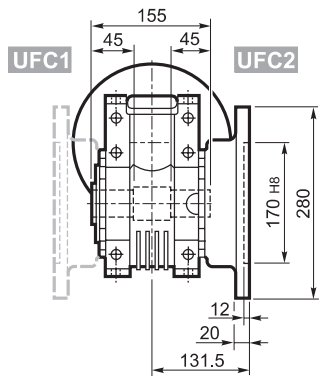
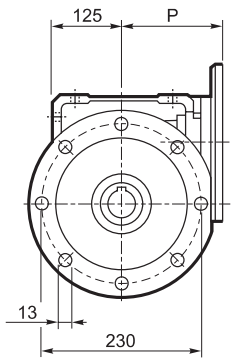

UFC_



		M	M1	M2	N	N1	N2	N3	N4	P	
W 110	P80 B5	19	21.8	6	200	165	130	—	M10x12	143	28
W 110	P90 B5	24	27.3	8	200	165	130	—	M10x12	143	28
W 110	P100 B5	28	31.3	8	250	215	180	13	13	151	29
W 110	P112 B5	28	31.3	8	250	215	180	13	13	151	29
W 110	P132 B5	38	41.3	10	300	265	230	16	14	226	31
W 110	P80 B14	19	21.8	6	120	100	80	7.5	7	143	27.5
W 110	P90 B14	24	27.3	8	140	115	95	6.5	9	143	27.5
W 110	P100 B14	28	31.3	8	160	130	110	13	9	151	27
W 110	P112 B14	28	31.3	8	160	130	110	13	9	151	27

* Tous le deux cotés

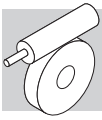

WR 110...P (IEC)

U

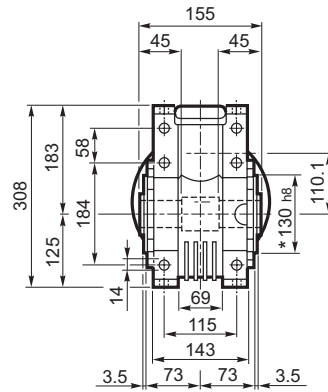
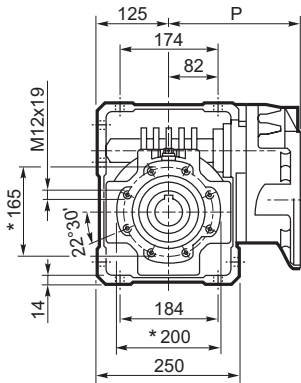

INPUT

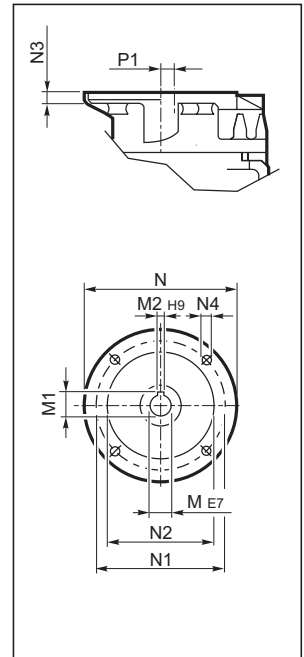

UF

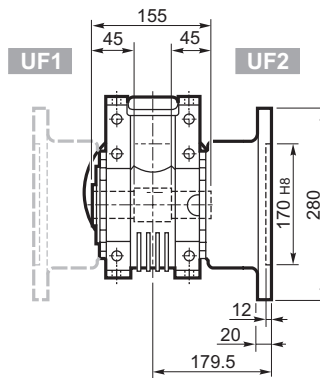
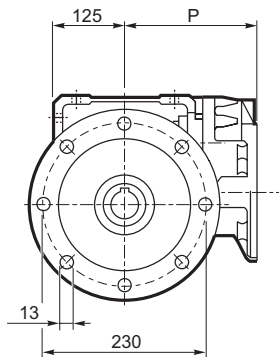

OUTPUT

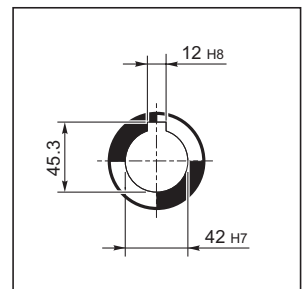

UFC

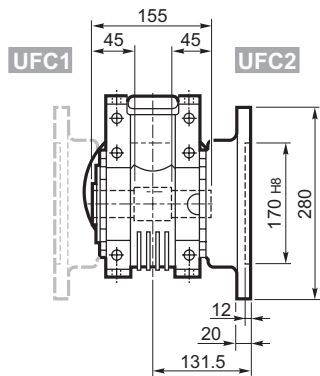
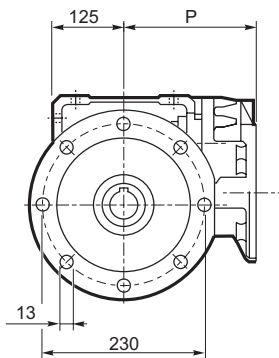

		M	M1	M2	N	N1	N2	N3	N4	P	P1	
WR 110	P71 B5	14	16.3	5	160	130	110	10	M8x14	185	58.6	30.5
WR 110	P80 B5	19	21.8	6	200	165	130	14	M10x15	204	21.1	31
WR 110	P90 B5	24	27.3	8	200	165	130	14	M10x15	204	21.1	31
WR 110	P100 B5	28	31.3	8	250	215	180	14	M12x13	213	21.1	32
WR 110	P112 B5	28	31.3	8	250	215	180	14	M12x13	213	21.1	32

* Tous le deux cotés

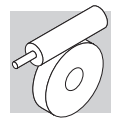

VF/W 49/110...P (IEC)

U

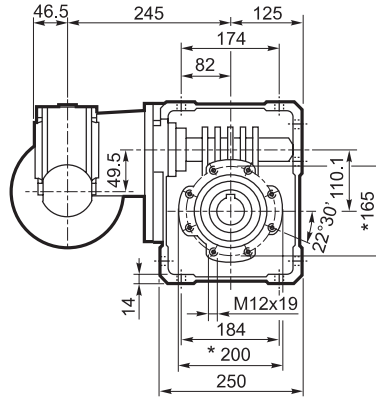
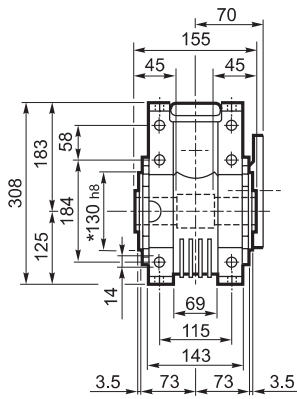

INPUT

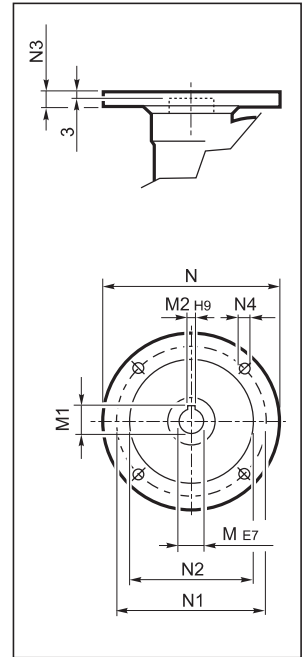

UF

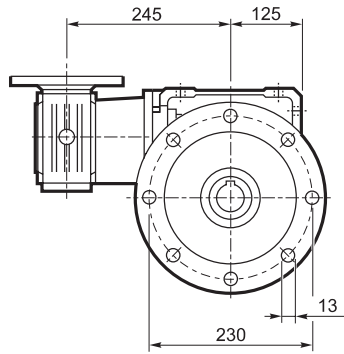
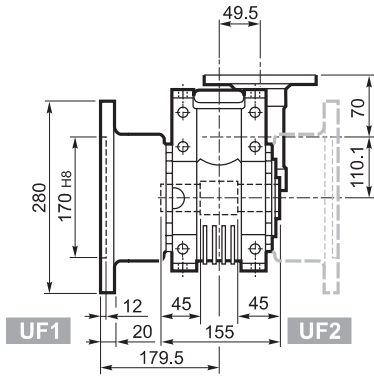

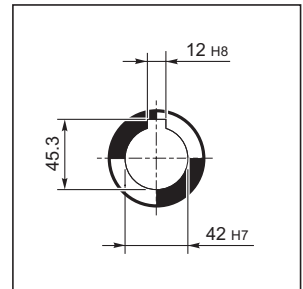

OUTPUT

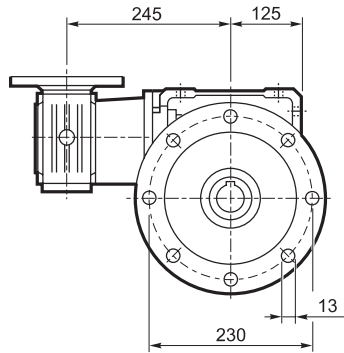
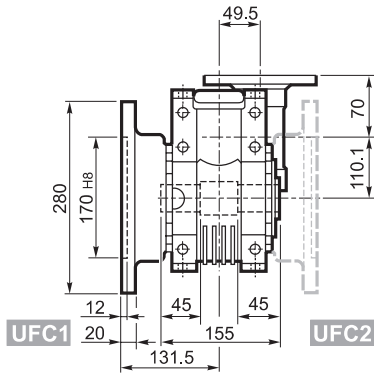

UFC



		M	M1	M2	N	N1	N2	N3	N4	
VF/W 49/110	P63 B5	11	12.8	4	140	115	95	10.5	9.5	33
VF/W 49/110	P71 B5	14	16.3	5	160	130	110	10.5	9.5	
VF/W 49/110	P80 B5	19	21.8	6	200	165	130	10	11.5	
VF/W 49/110	P63 B14	11	12.8	4	90	75	60	7	6	
VF/W 49/110	P71 B14	14	16.3	5	105	85	70	10.5	6.5	
VF/W 49/110	P80 B14	19	21.8	6	120	100	80	10	7	

* Tous le deux cotés

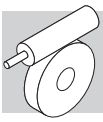

VF 130...P (IEC)

A

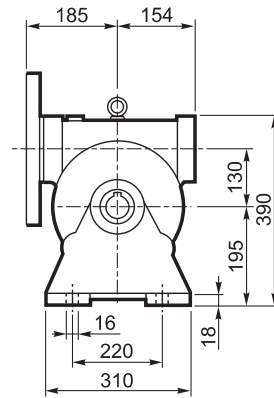
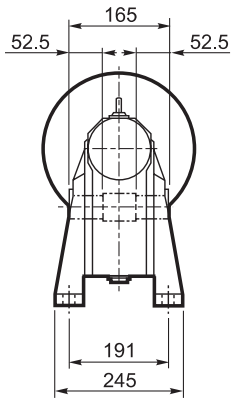

N

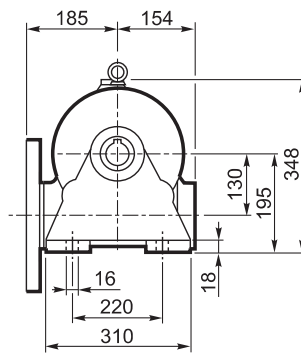
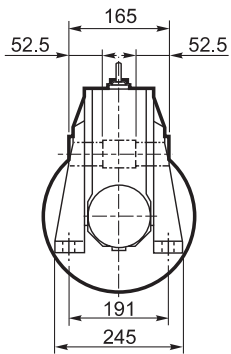

V

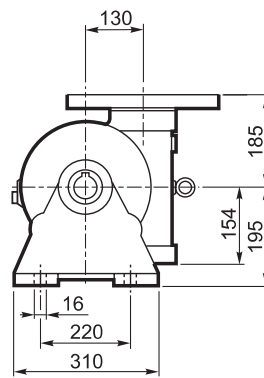
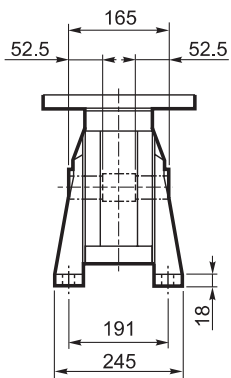

INPUT

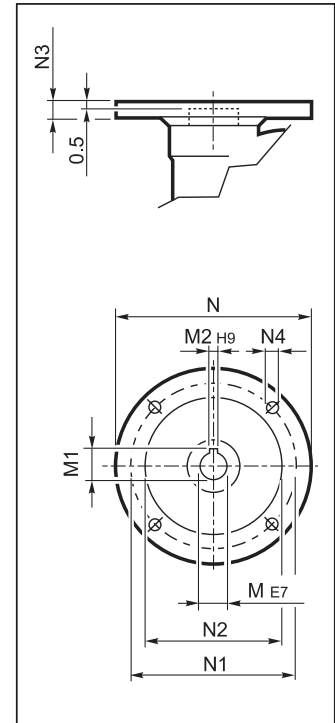



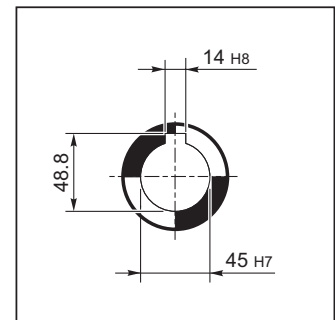

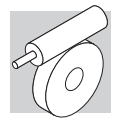
OUTPUT



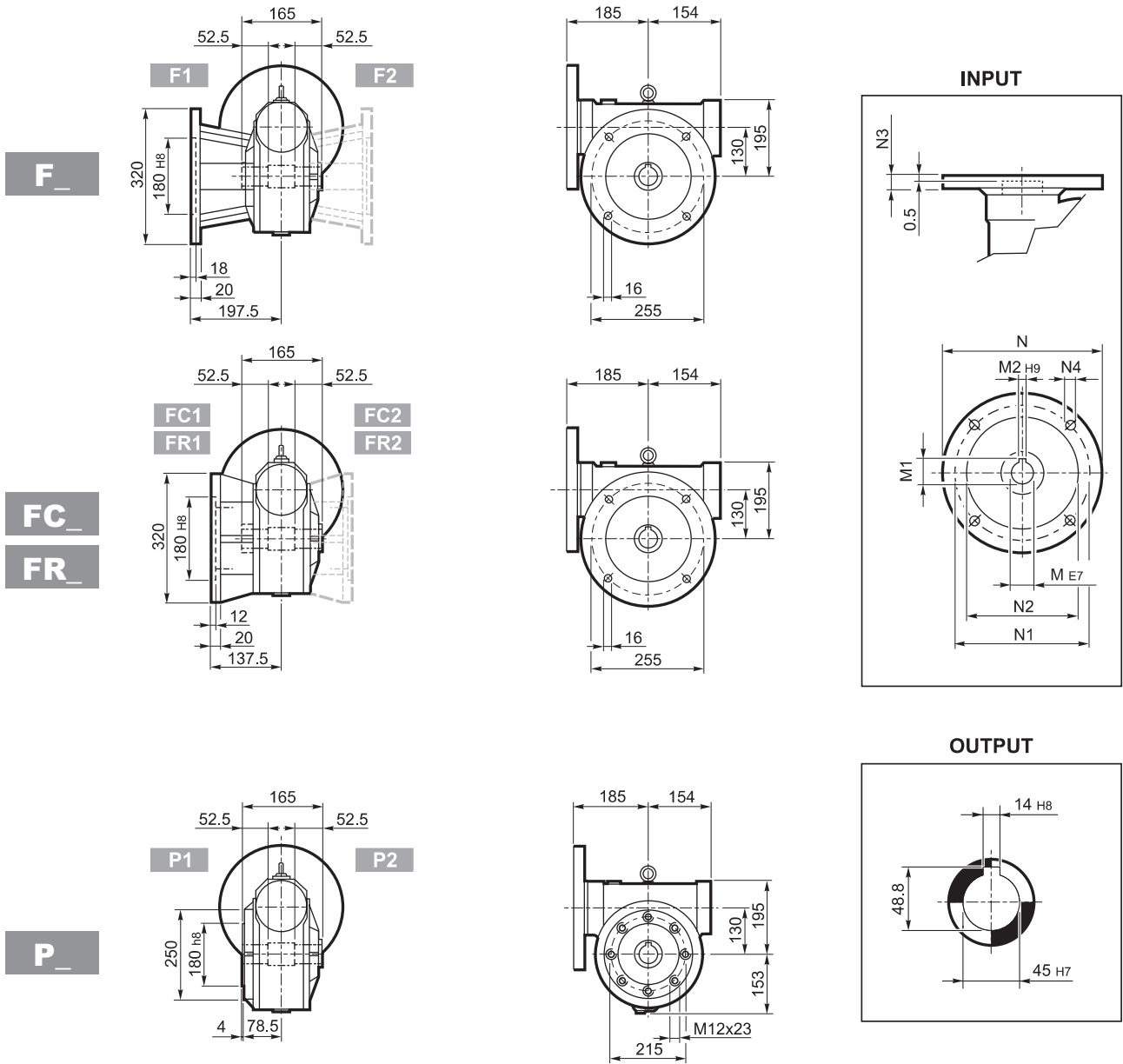

VF 130...P (IEC)



		M	M1	M2	N	N1	N2	N3	N4	
VF130	P90 B5	24	27.3	8	200	165	130	17	11	49
VF130	P100 B5	28	31.3	8	250	215	180	17	13	
VF130	P112 B5	28	31.3	8	250	215	180	17	13	
VF130	P132 B5	38	40.1#	10	300	265	230	17	13	

Clavette à hauteur réduite

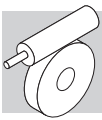

VFR 130...P (IEC)

A

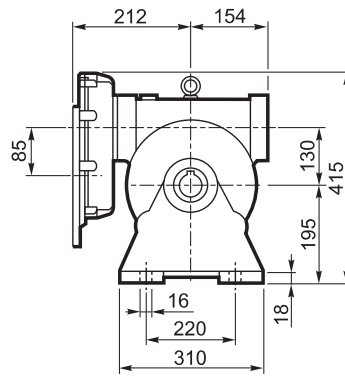
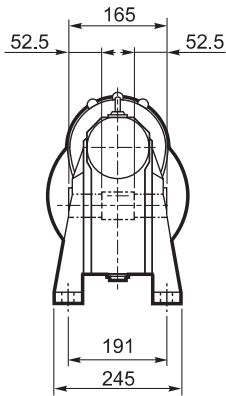

INPUT

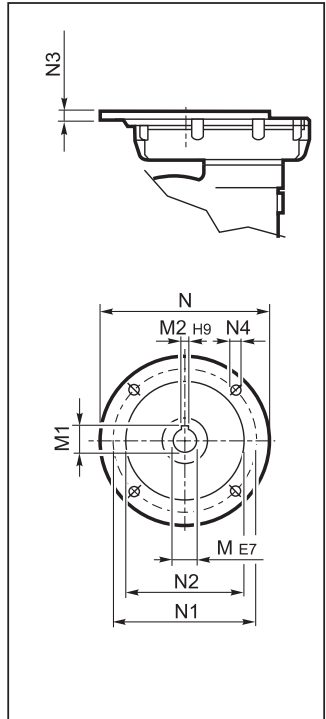

N

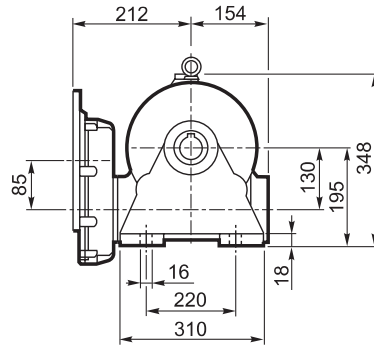
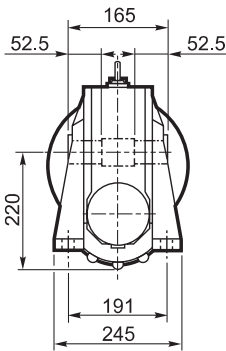

OUTPUT

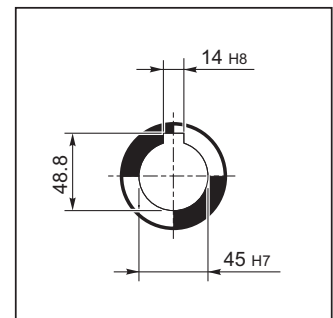

V

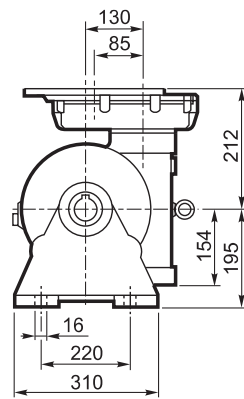
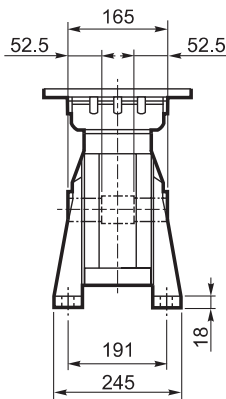

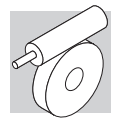

VFR 130...P (IEC)

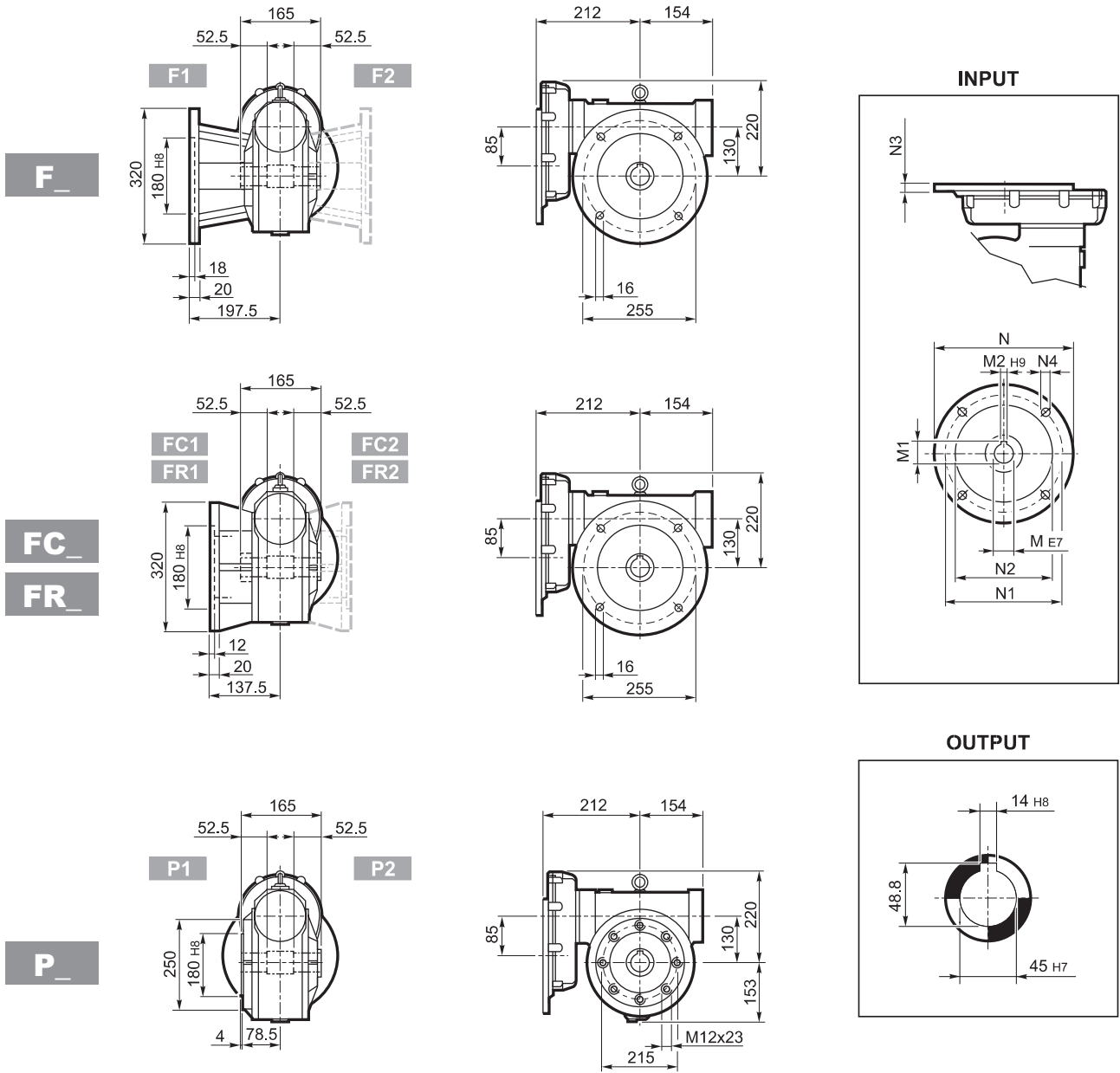

		M	M1	M2	N	N1	N2	N3	N4	
VFR 130	P80 B5	19 K6	21.8	6	200	165	130	12	M10x25	57
VFR 130	P90 B5	24 K6	27.3	8	200	165	130	12	M10x25	
VFR 130	P100 B5	28 J6	29.1#	8	250	215	180	13	M12x35	
VFR 130	P112 B5	28 J6	29.1#	8	250	215	180	13	M12x35	

Clavette à hauteur réduite

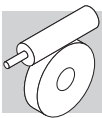

W/VF 63/130...M

A

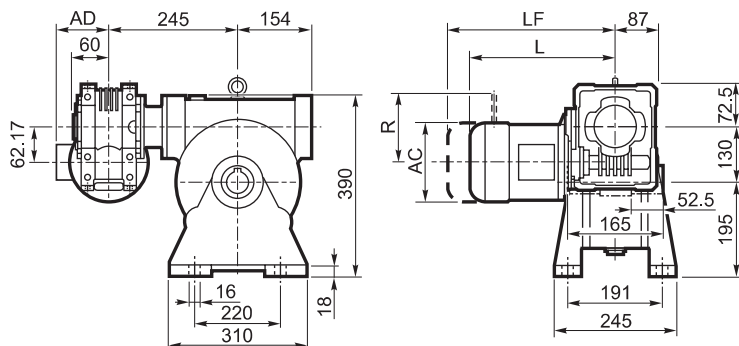

F_

FC_

FR_

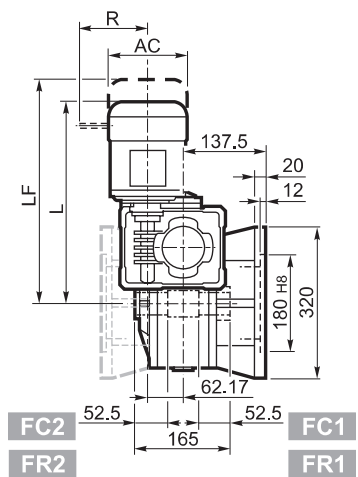
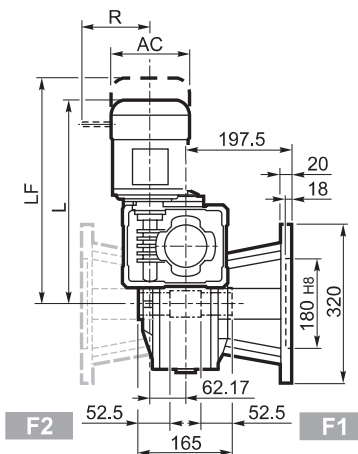
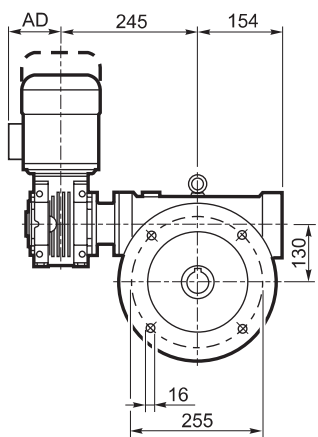

P_

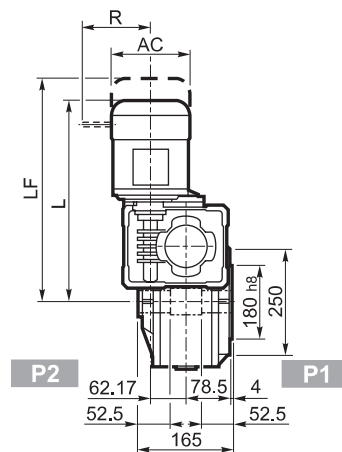
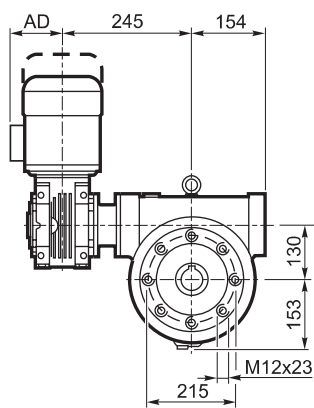

OUTPUT

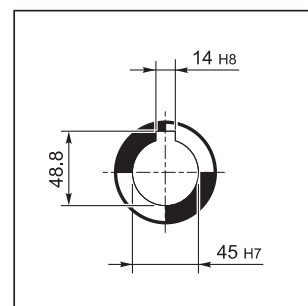

			M_				M...FD M...FA		M...FD		M...FA	
			AC	L	AD	Kg	LF	Kg	R	AD	R	AD
			138	419	108	63	480	65	103	135	124	108
W/VF 63/130	S1	M1	156	447	119	68	523	71	129	146	134	119

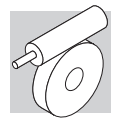

W/VF 63/130...P (IEC)

A

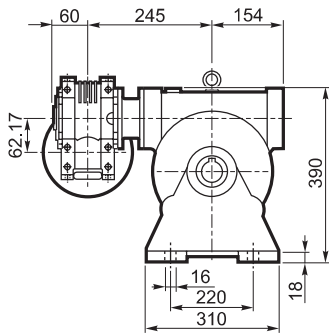

F_

FC_

FR_

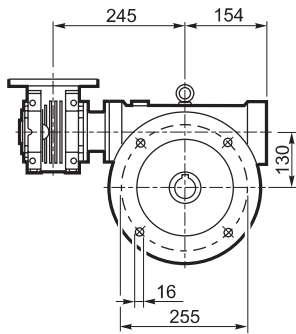

F2

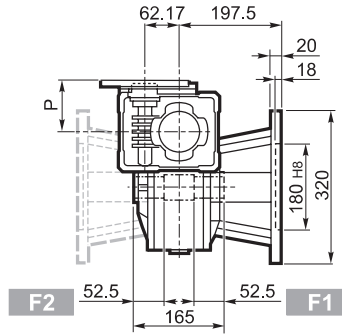

F1

FC2

FR2

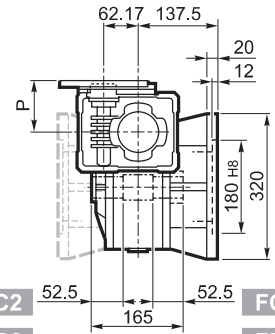

FC1

FR1

P_

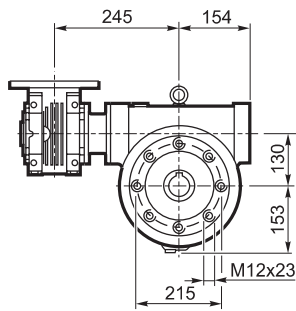

P2

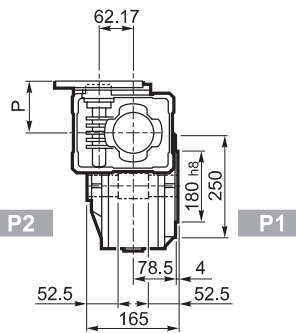

P1

OUTPUT

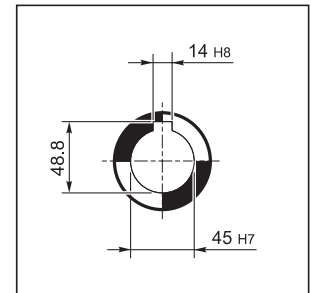

INPUT

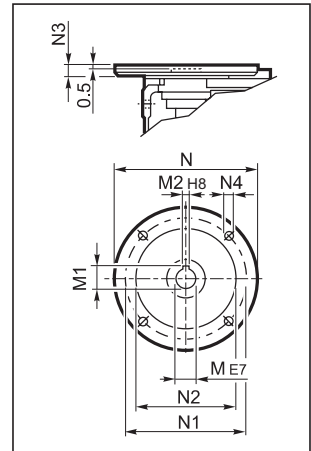

		M	M1	M2	N	N1	N2	N3	N4	P	
W/VF 63/130	P71 B5	14	16.3	5	160	130	110	11	9	95	57
W/VF 63/130	P80 B5	19	21.8	6	200	165	130	12	11.5	102	
W/VF 63/130	P90 B5	24	27.3	8	200	165	130	12	11.5	102	
W/VF 63/130	P71 B14	14	16.3	5	105	85	70	11	6.5	95	
W/VF 63/130	P80 B14	19	21.8	6	120	100	80	11	6.5	102	
W/VF 63/130	P90 B14	24	27.3	8	140	115	95	11	8.5	102	

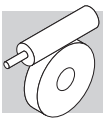

VF 150...P (IEC)

A

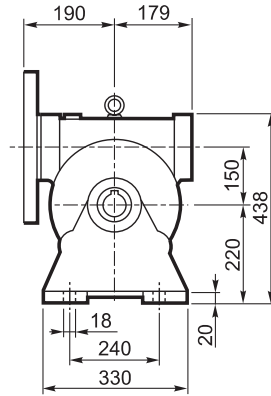
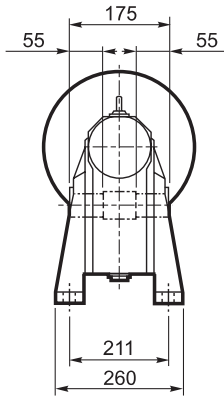

INPUT

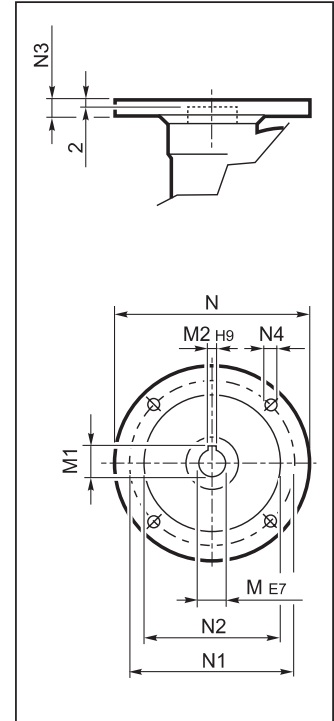

N

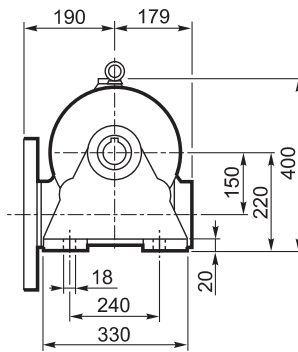
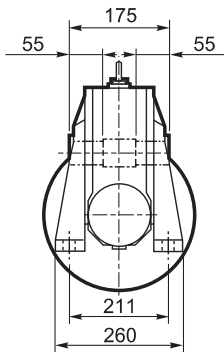

OUTPUT

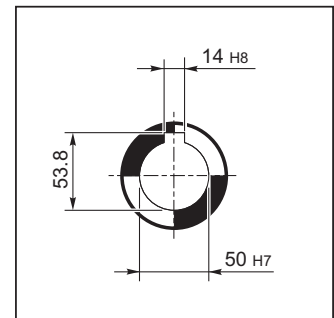

V

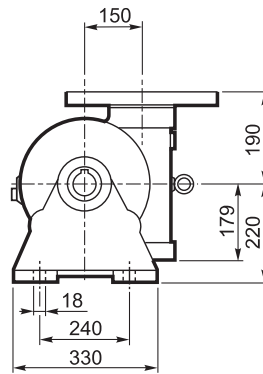
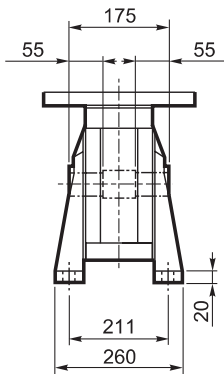

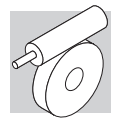

VF 150...P (IEC)

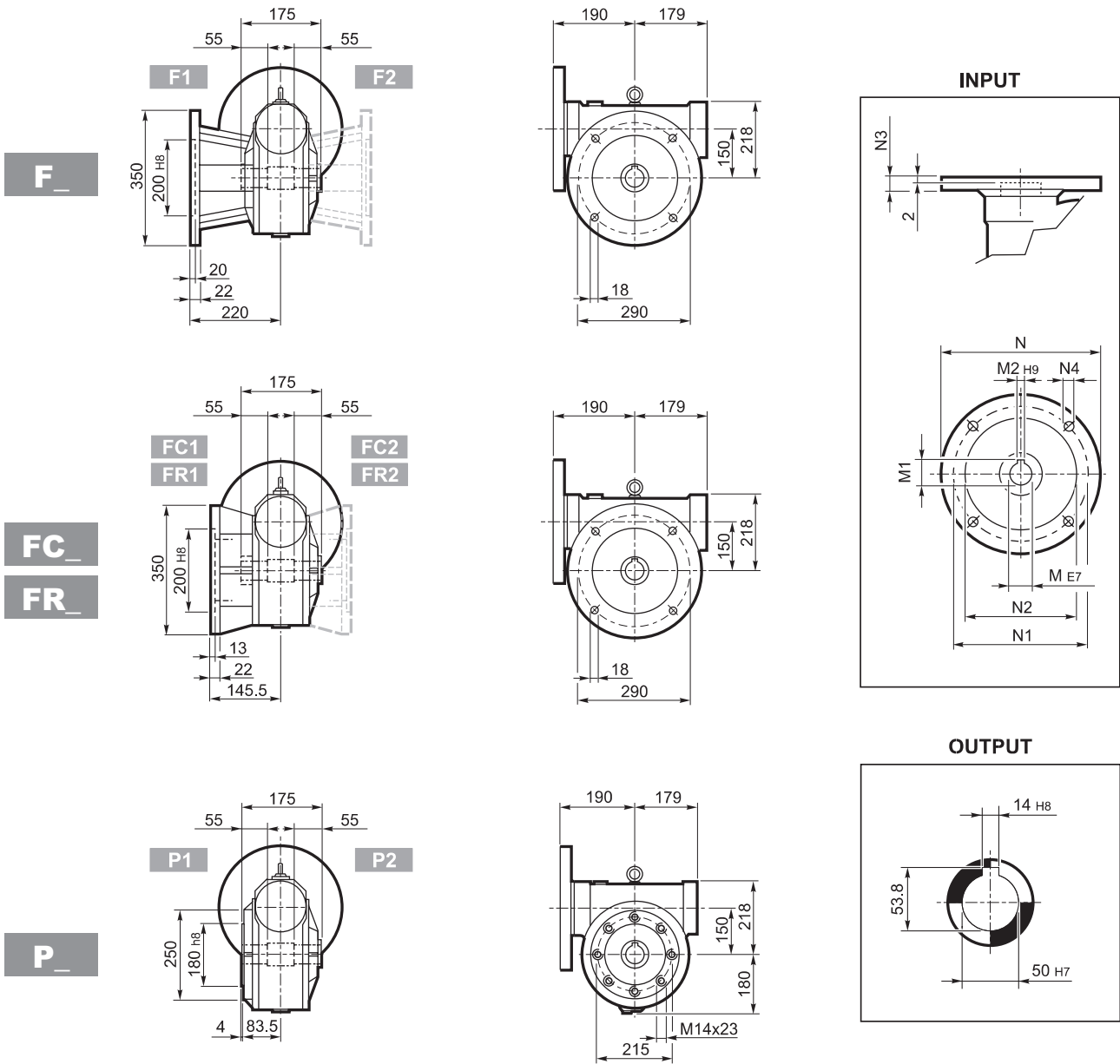

		M	M1	M2	N	N1	N2	N3	N4	
VF 150	P100 B5	28	31.3	8	250	215	180	11	13	60
VF 150	P112 B5	28	31.3	8	250	215	180	11	13	
VF 150	P132 B5	38	41.3	10	300	265	230	16	13	
VF 150	P160 B5	42	44.6#	12	350	300	250	18	18	

Clavette à hauteur réduite

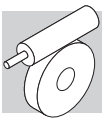

VFR 150...P (IEC)

A

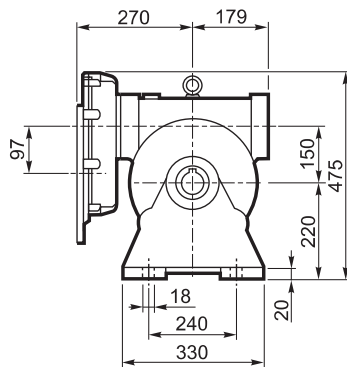
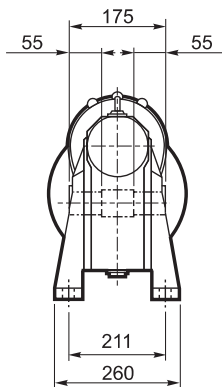

INPUT

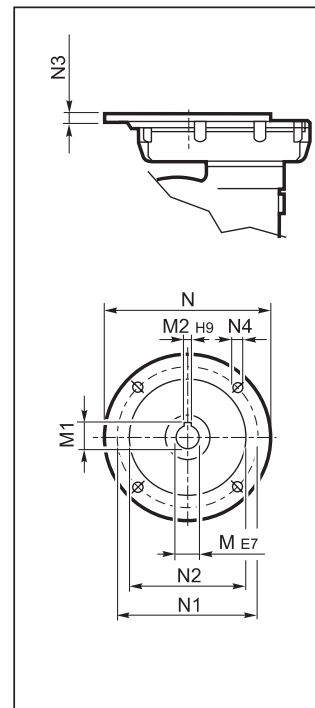

N

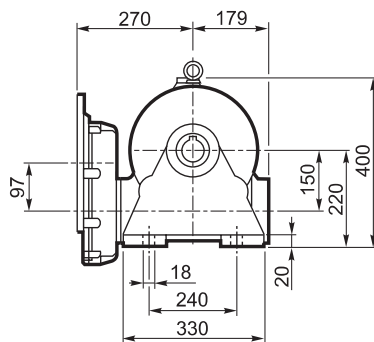
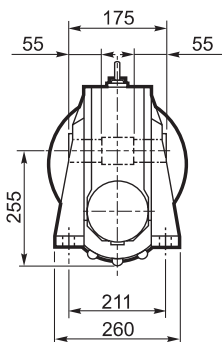

OUTPUT

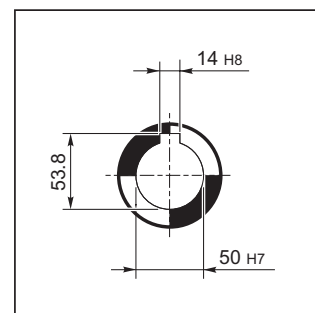

V

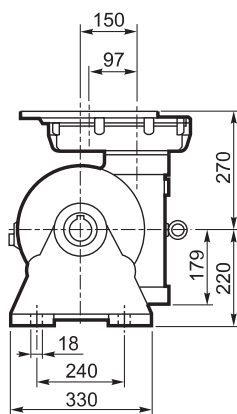
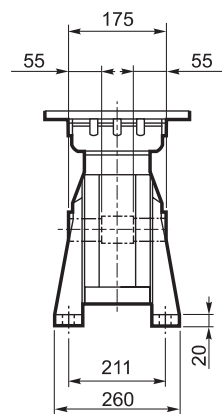

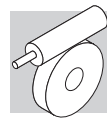

VFR 150...P (IEC)

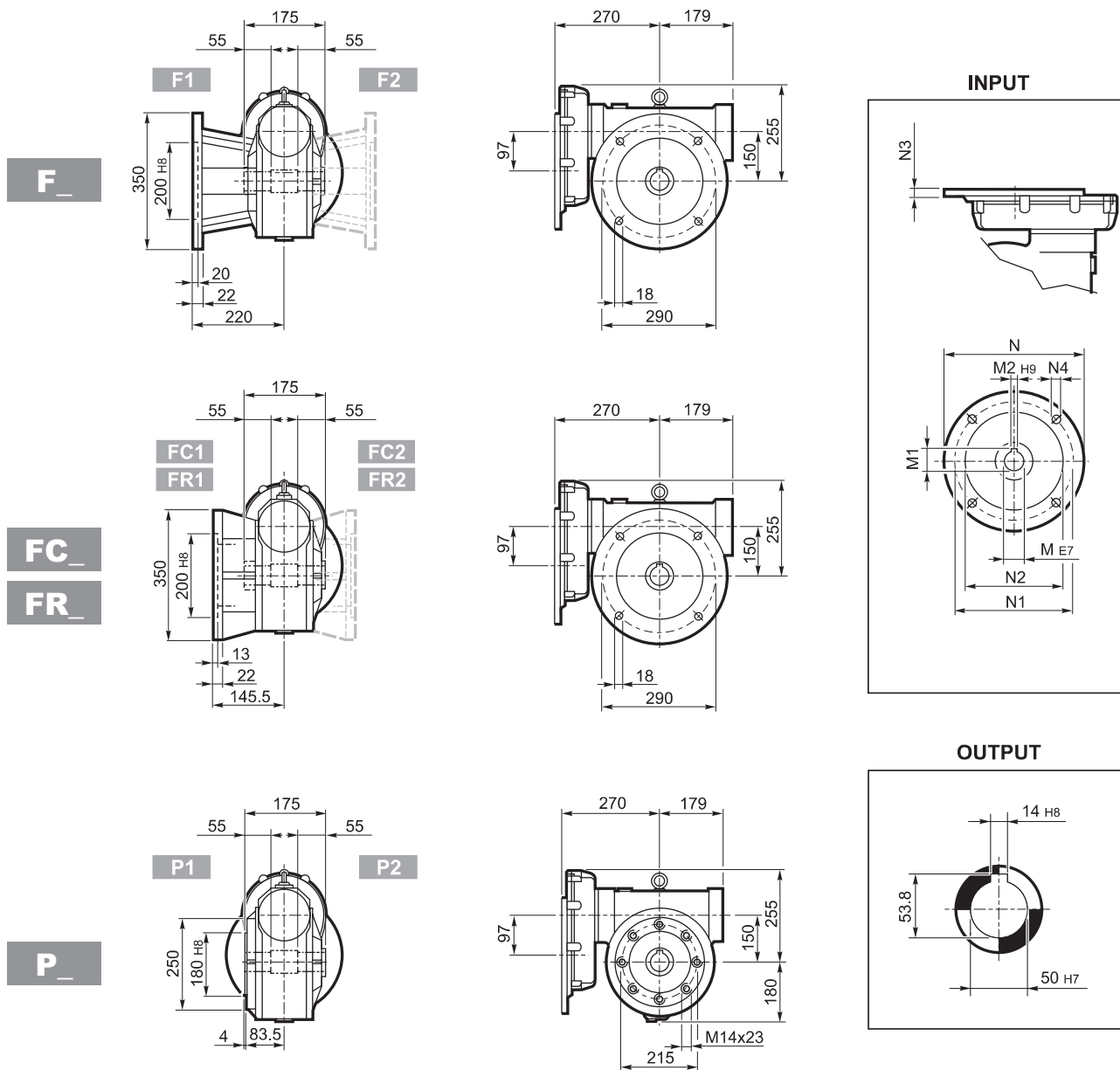

		M	M1	M2	N	N1	N2	N3	N4	
VFR 150	P90 B5	24 K6	27.3	8	200	165	130	13	M10x25	71
VFR 150	P100 B5	28 K6	31.3	8	250	215	180	13	M12x35	
VFR 150	P112 B5	28 J6	31.3	8	250	215	180	13	M12x35	
VFR 150	P132 B5	38 J6	39.6#	10	300	265	230	13	M12x35	

Clavette à hauteur réduite

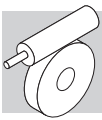

W/VF 86/150...M

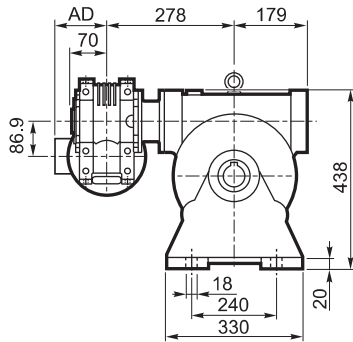

A

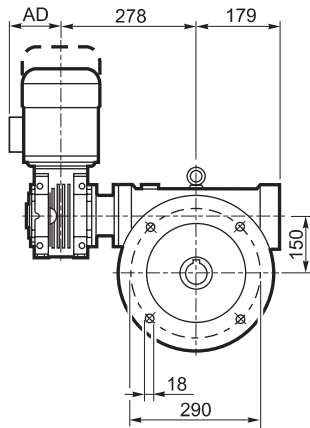
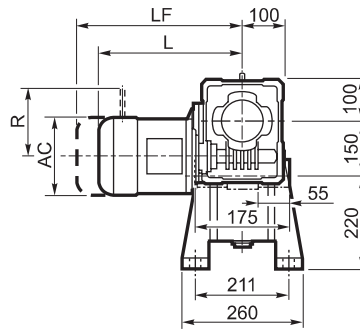

F_

FC_

FR_

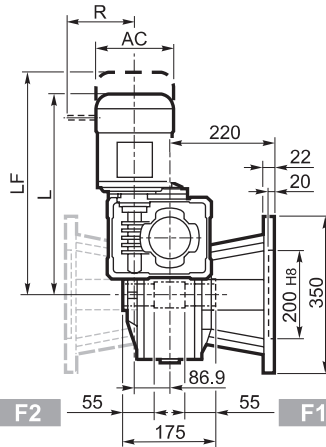

F2

F1

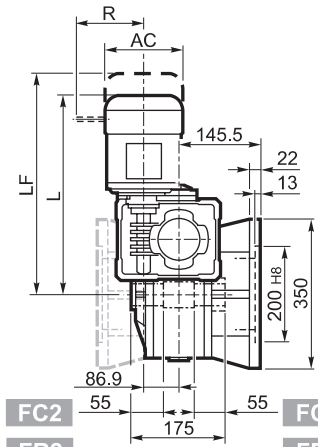

FC2

FC1

FR2

FR1

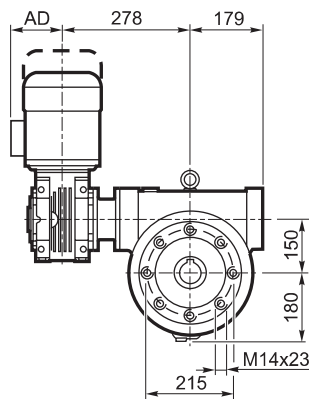

P_

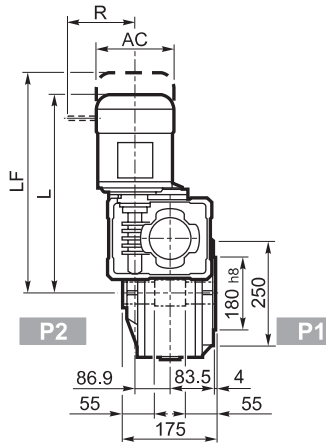

P2

P1

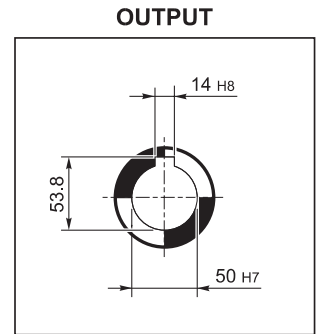

			M_				M...FD M...FA		M...FD		M...FA	
			AC	L	AD		LF		R	AD	R	AD
			138	474	108	82	385	84	103	135	124	108
W/VF 86/150	S1	M1	156	499	119	86	425	89	129	146	134	119
W/VF 86/150	S2	M2S	193	542	142	91	488	97	160	158	160	142
W/VF 86/150	S3	M3L	193	574	142	99	515	104	160	158	160	142

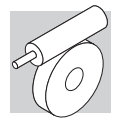

W/VF 86/150...P (IEC)

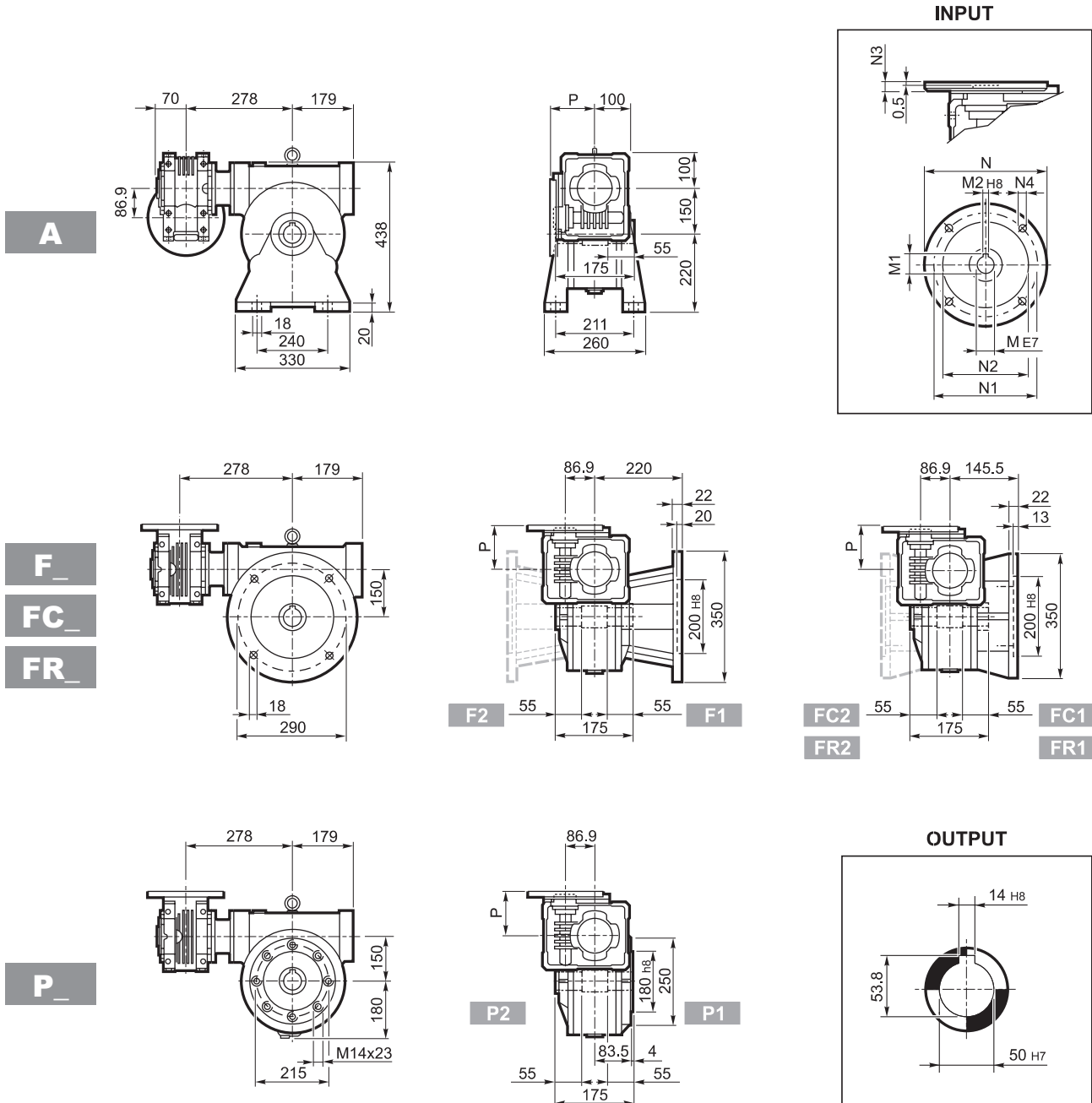

		M	M1	M2	N	N1	N2	N3	N4	P	
W/VF 86/150	P71 B5	14	16.3	5	160	130	110	11	9	128	75
W/VF 86/150	P80 B5	19	21.8	6	200	165	130	12	11.5	128	
W/VF 86/150	P90 B5	24	27.3	8	200	165	130	12	11.5	128	
W/VF 86/150	P100 B5	28	31.3	8	250	215	180	13	12.5	136	
W/VF 86/150	P112 B5	28	31.3	8	250	215	180	13	12.5	136	
W/VF 86/150	P80 B14	19	21.8	6	120	100	80	7.5	6.5	128	
W/VF 86/150	P90 B14	24	27.3	8	140	115	95	7.5	8.5	128	
W/VF 86/150	P100 B14	28	31.3	8	160	130	110	10	8.5	136	
W/VF 86/150	P112 B14	28	31.3	8	160	130	110	10	8.5	136	

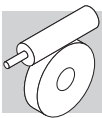

VF 185...P (IEC)

A

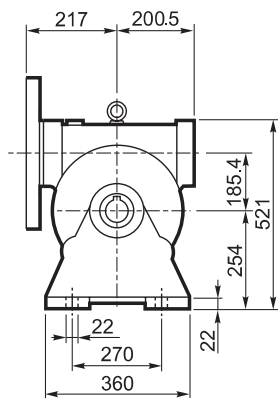
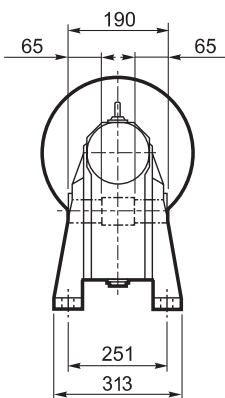

N

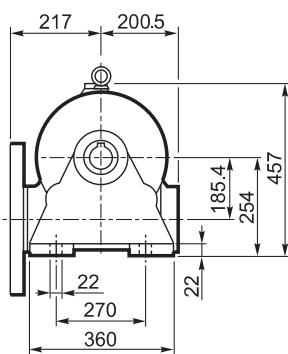
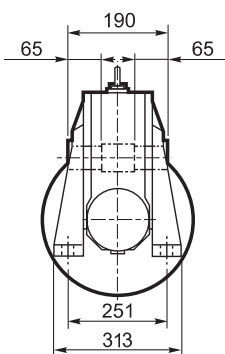

V

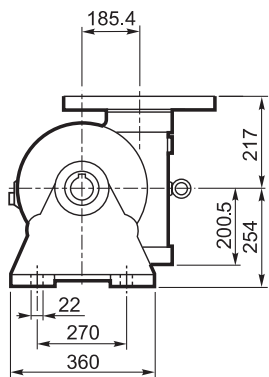
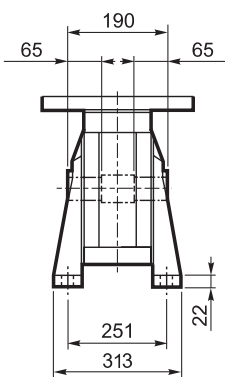

INPUT

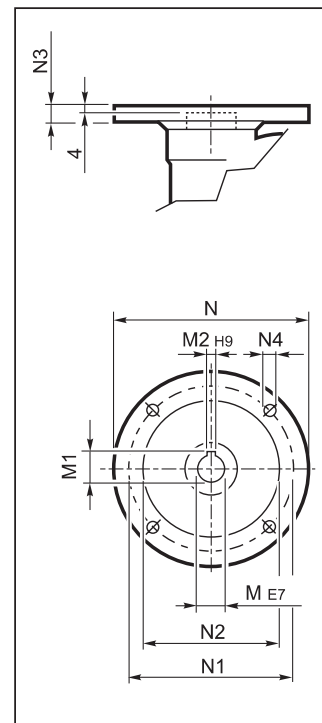

OUTPUT

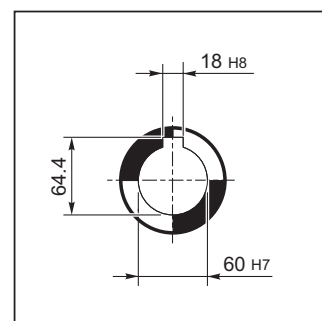

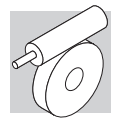

VF 185...P (IEC)

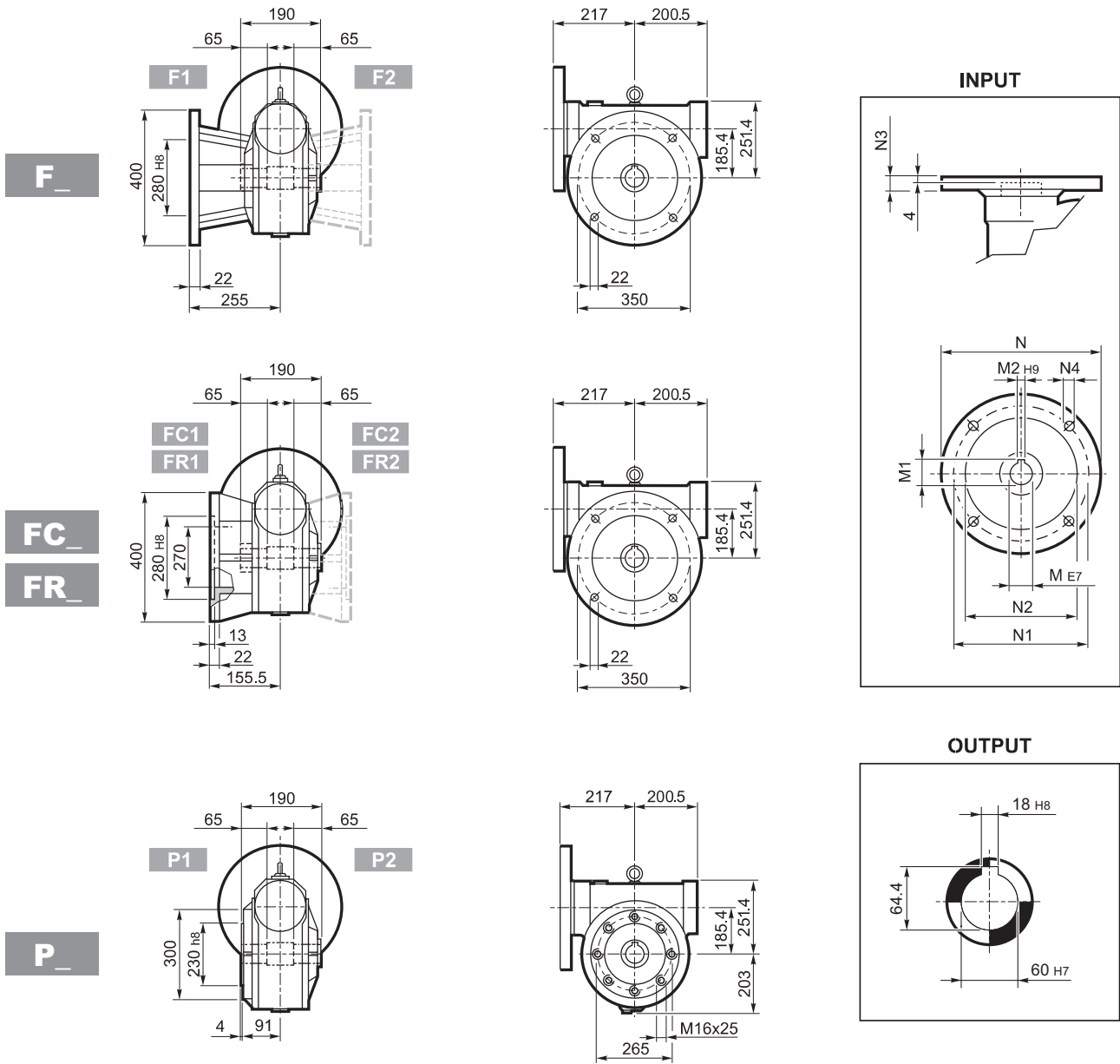

		M	M1	M2	N	N1	N2	N3	N4	
VF 185	P100 B5	28	31.3	8	250	215	180	16	13	94
VF 185	P112 B5	28	31.3	8	250	215	180	16	13	
VF 185	P132 B5	38	41.3	10	300	265	230	16	13	
VF 185	P160 B5	42	45.3	12	350	300	250	18	18	
VF 185	P180 B5	48	51.2#	14	350	300	250	18	18	

Clavette à hauteur réduite

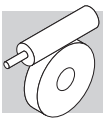

VFR 185...P (IEC)

A

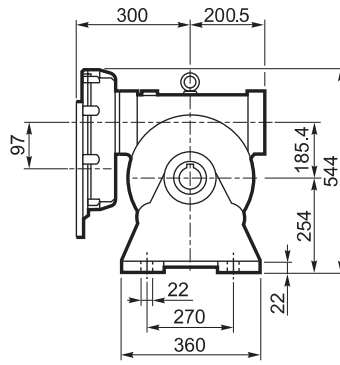
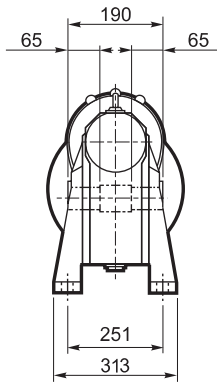

INPUT

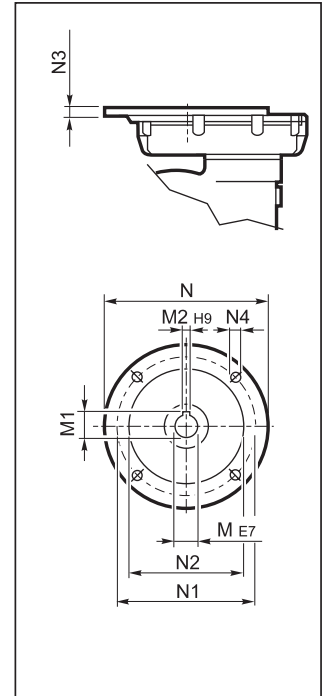

N

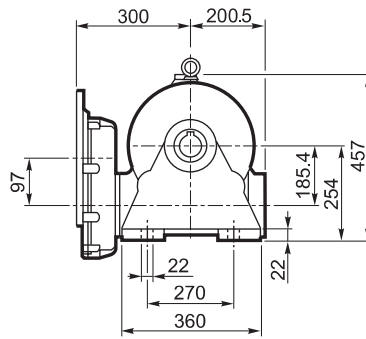
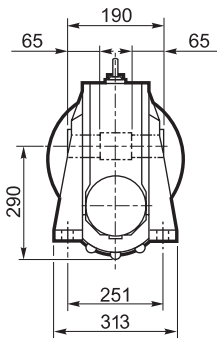

OUTPUT

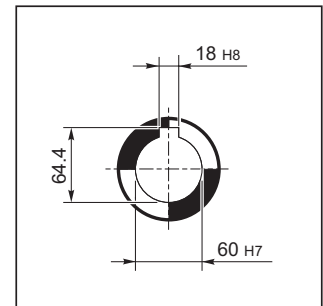



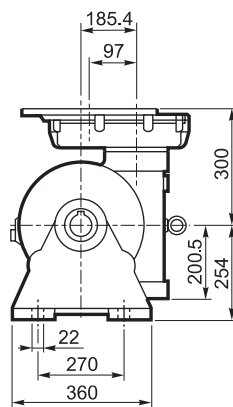
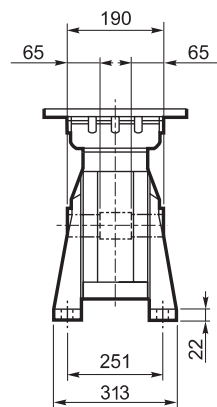

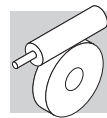
V



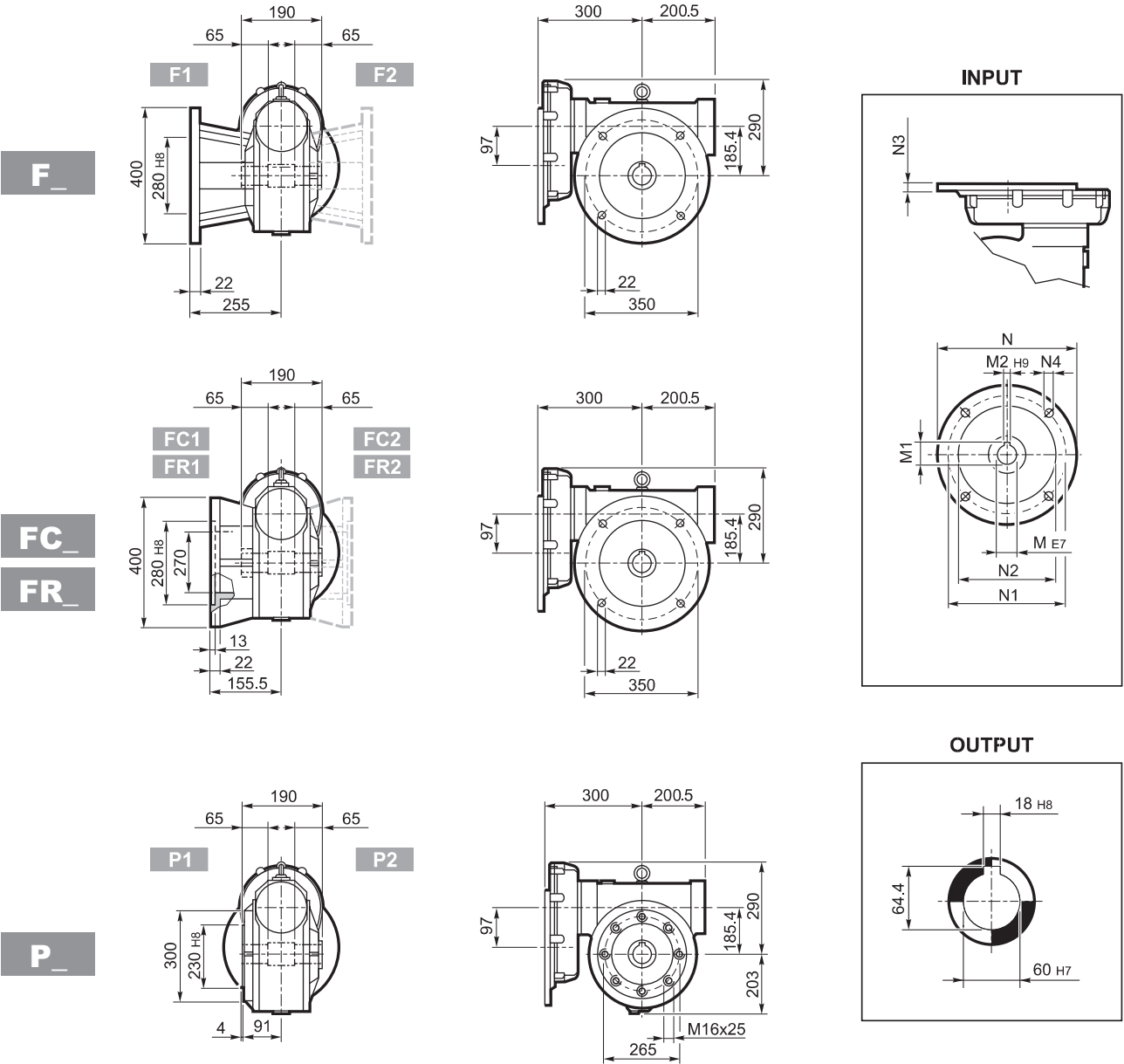

VFR 185...P (IEC)



		M	M1	M2	N	N1	N2	N3	N4	
VFR 185	P90 B5	24 K6	27.3	8	200	165	130	13	M10x25	110
VFR 185	P100 B5	28 K6	31.3	8	250	215	180	13	M12x35	
VFR 185	P112 B5	28 K6	31.3	8	250	215	180	13	M12x35	
VFR 185	P132 B5	38 J6	39.6#	10	300	265	230	13	M12x35	

Clavette à hauteur réduite

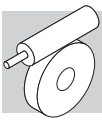

W/VF 86/185...M

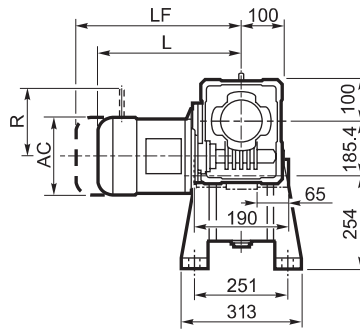
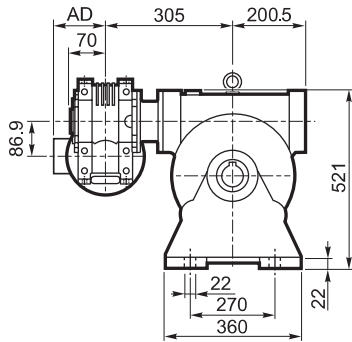

A

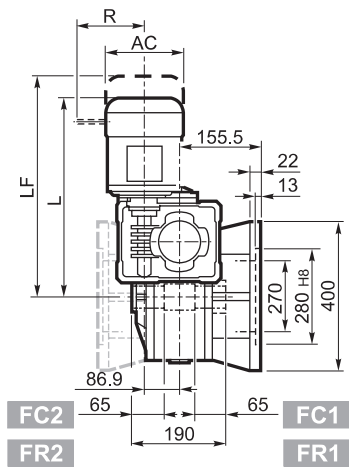
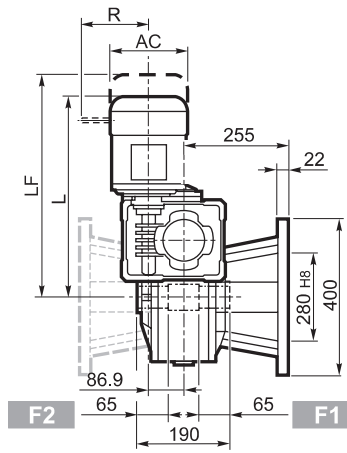
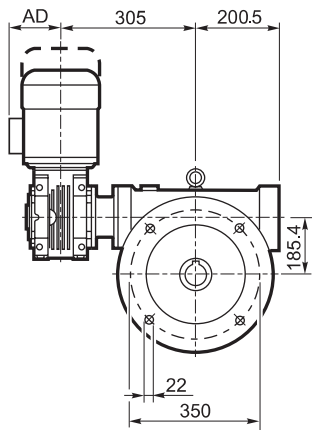

F_

FC_

FR_

F2

F1

FC2

FC1

FR2

FR1

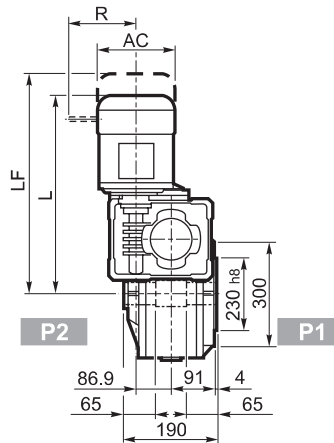
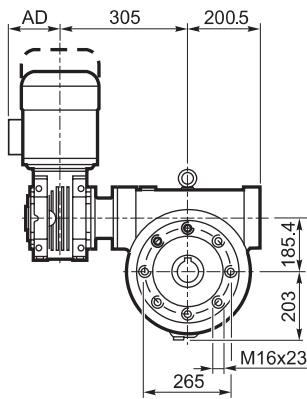

P2

P1

OUTPUT

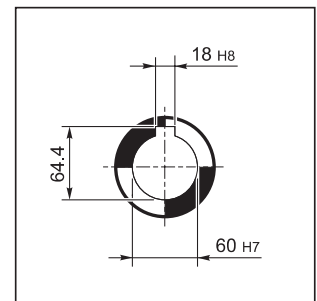

P_

			M_				M...FD M...FA		M...FD		M...FA	
			AC	L	AD		LF		R	AD	R	AD
			138	509	108	116	570	118	103	135	124	108
W/VF 86/185	S2	M2S	156	534	119	120	610	123	129	146	134	119
W/VF 86/185	S3	M3S	193	577	142	125	673	131	160	158	160	142
W/VF 86/185	S3	M3L	193	609	142	133	700	138	160	158	160	142

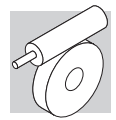

W/VF 86/185...P (IEC)

A

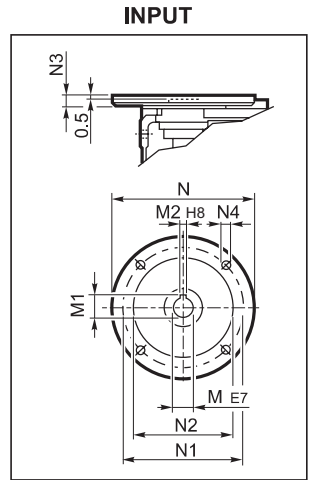
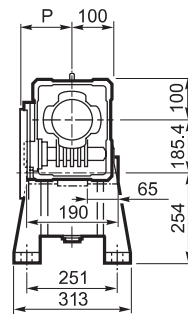
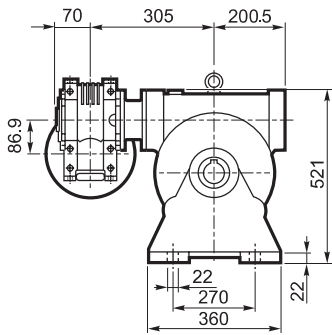

F_

FC_

FR_

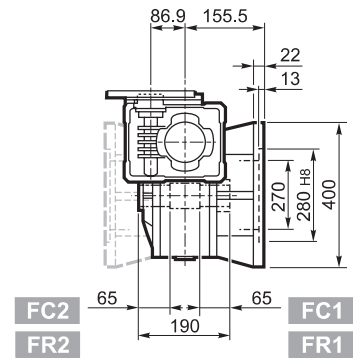
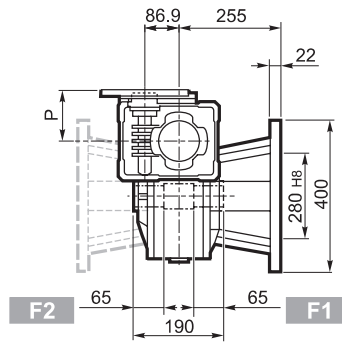
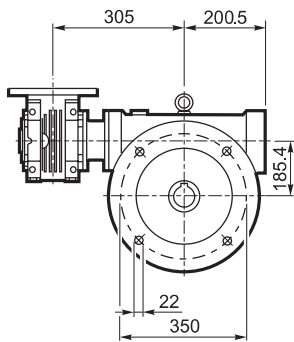

P_

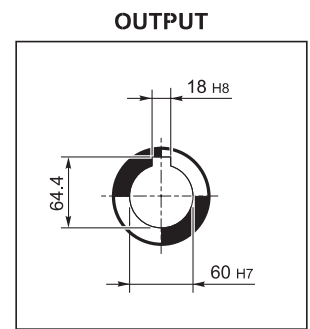
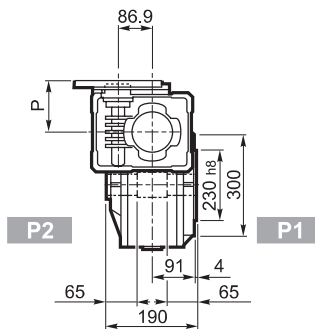
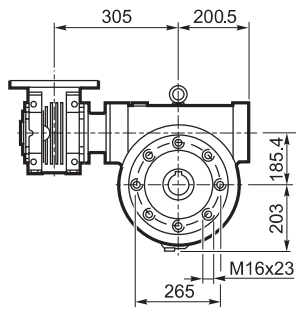

		M	M1	M2	N	N1	N2	N3	N4	P	
W/VF 86/185	P71 B5	14	16.3	5	160	130	110	11	9	128	109
W/VF 86/185	P80 B5	19	21.8	6	200	165	130	12	11.5	128	
W/VF 86/185	P90 B5	24	27.3	8	200	165	130	12	11.5	128	
W/VF 86/185	P100 B5	28	31.3	8	250	215	180	13	12.5	136	
W/VF 86/185	P112 B5	28	31.3	8	250	215	180	13	12.5	136	
W/VF 86/185	P80 B14	19	21.8	6	120	100	80	7.5	6.5	128	
W/VF 86/185	P90 B14	24	27.3	8	140	115	95	7.5	8.5	128	
W/VF 86/185	P100 B14	28	31.3	8	160	130	110	10	8.5	136	
W/VF 86/185	P112 B14	28	31.3	8	160	130	110	10	8.5	136	

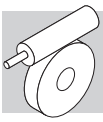

VF 210...P (IEC)

A

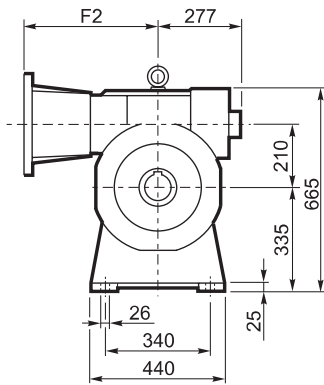
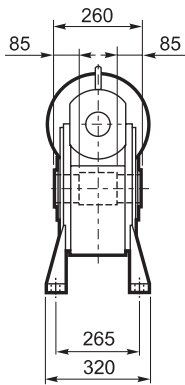

N

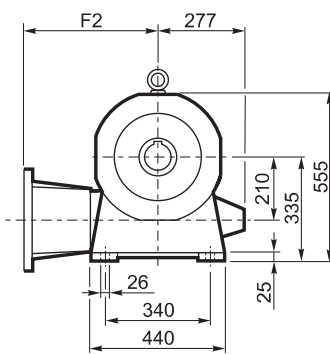
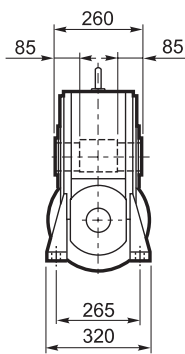

INPUT

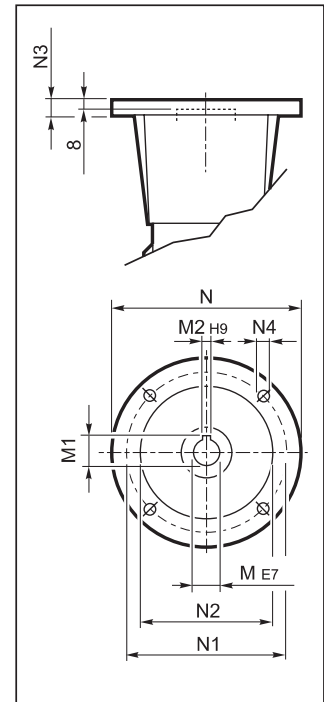

OUTPUT

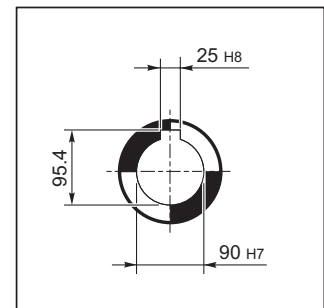

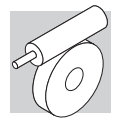

VF 210...P (IEC)

V

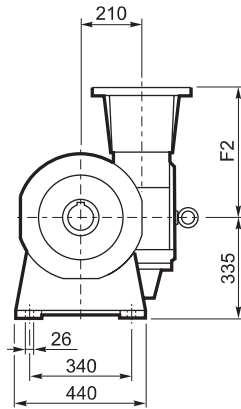
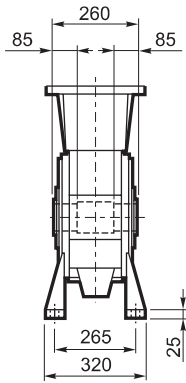

P

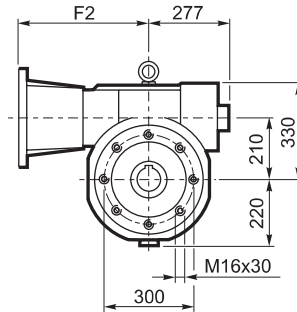
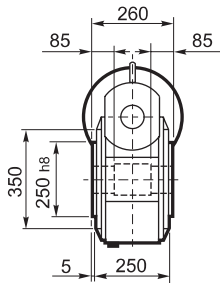

INPUT

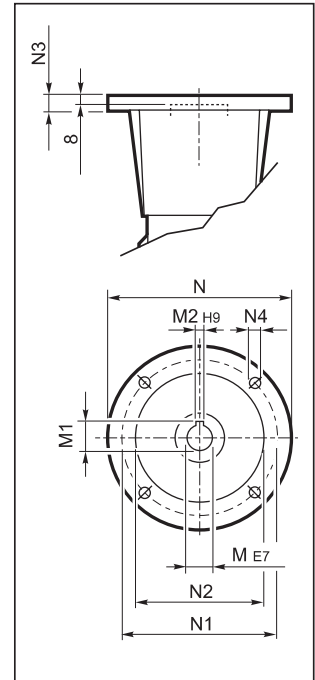

OUTPUT

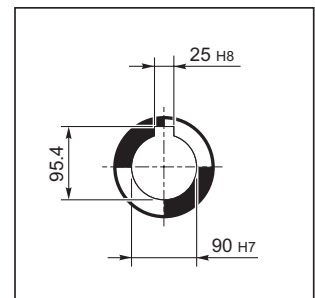

Dans les formes de construction A et P, il est prévu un ventilateur de refroidissement.
 Dans la version P(IEC), la fourniture du joint complet d'accouplement moteur à été prévue de série.

		F2	M	M1	M2	N	N1	N2	N3	N4	
VF 210	P132 B5	485	38	41.3	10	300	265	230	25	M12	210
VF 210	P160 B5	460	42	45.3	12	350	300	250	22	18	
VF 210	P180 B5	460	48	51.8	14	350	300	250	22	18	
VF 210	P200 B5	485	55	59.3	16	400	350	300	25	M16	
VF 210	P225 B5	490	60	64.4	18	450	400	350	22	18 #	

N. 8 trous 45°

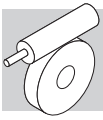

VFR 210...P (IEC)

A

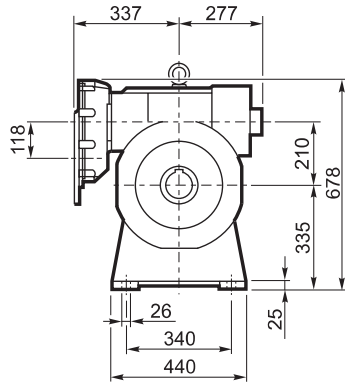
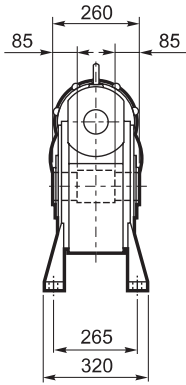

N

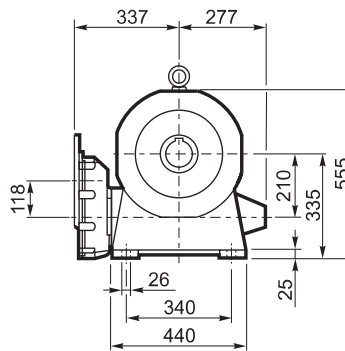
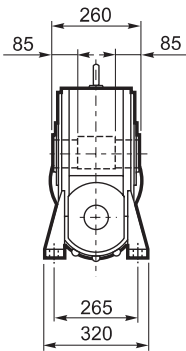

INPUT

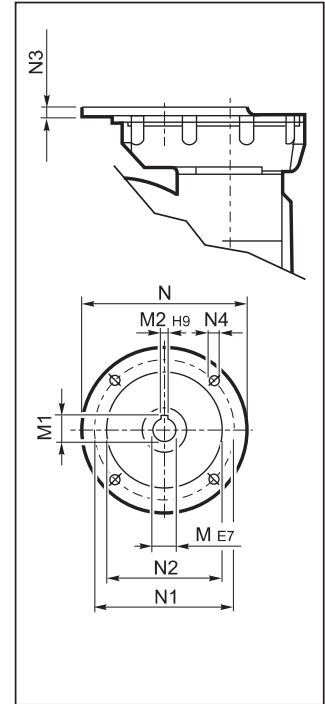

OUTPUT

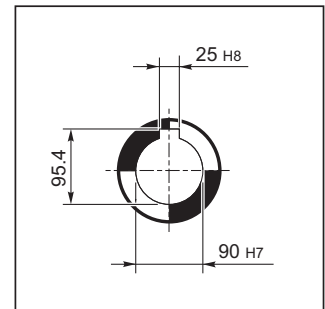

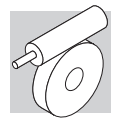

VFR 210...P (IEC)

V

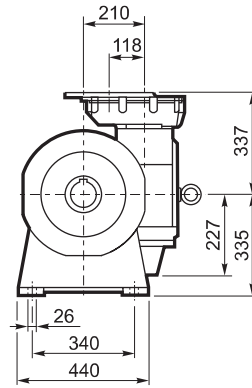
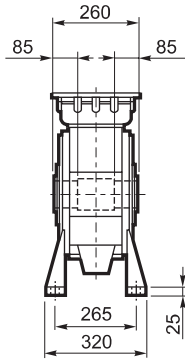

P

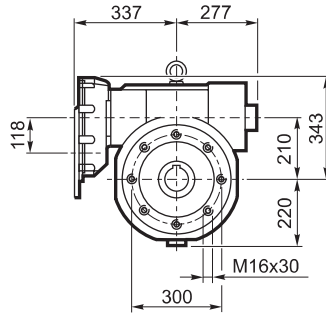
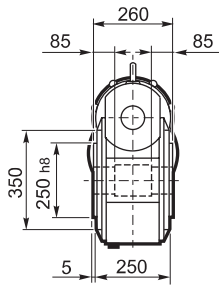

INPUT

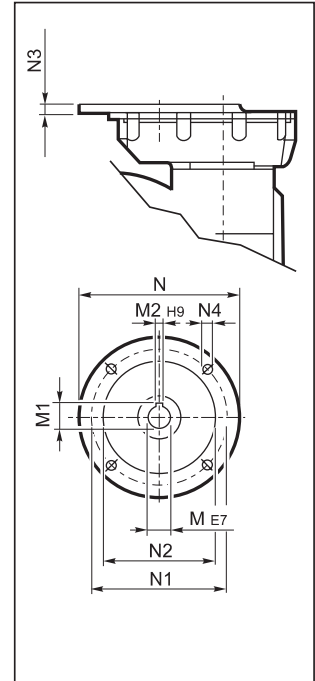

OUTPUT

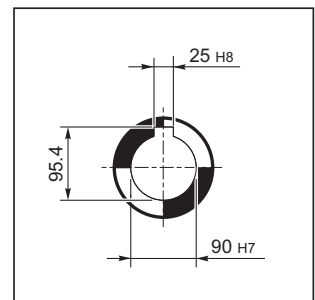

Dans les formes de construction A et P, il est prévu un ventilateur de refroidissement.

		M	M1	M2	N	N1	N2	N3	N4	
VFR 210	P100 B5	28 K6	31.3	8	250	215	180	13	M12x35	185
VFR 210	P112 B5	28 K6	31.3	8	250	215	180	13	M12x35	
VFR 210	P132 B5	38 J6	41.3	10	300	265	230	13	M12x35	
VFR 210	P160 B5	42 J6	44.3#	12	350	300	250	18	M16x60	

Clavette à hauteur réduite

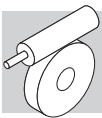

VF/VF 130/210...P (IEC)

A

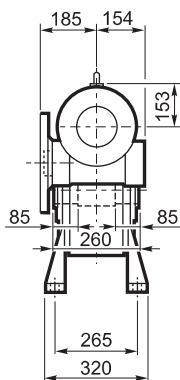
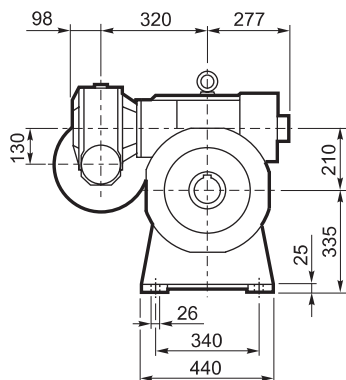

P

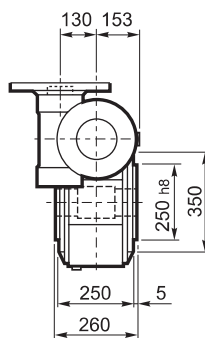
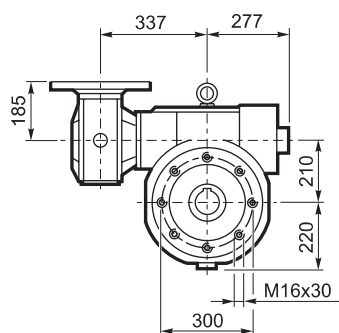

INPUT

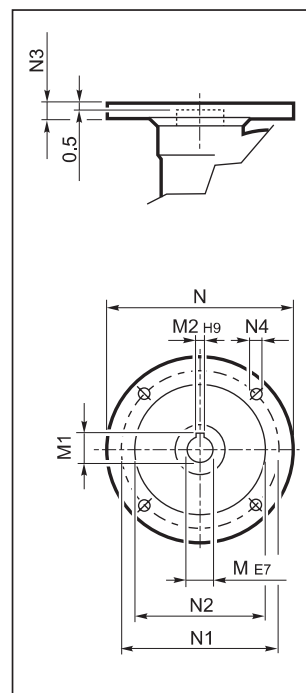

OUTPUT

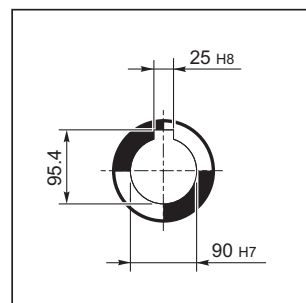

Dans les formes de construction A et P, il est prévu un ventilateur de refroidissement.

		M	M1	M2	N	N1	N2	N3	N4	
VF/VF 130/210	P90 B5	24	27.3	8	200	165	130	17	11	225
VF/VF 130/210	P100 B5	28	31.3	8	250	215	180	17	13	
VF/VF 130/210	P112 B5	28	31.3	8	250	215	180	17	13	
VF/VF 130/210	P132 B5	38	40.1#	10	300	265	230	17	13	

Clavette à hauteur réduite

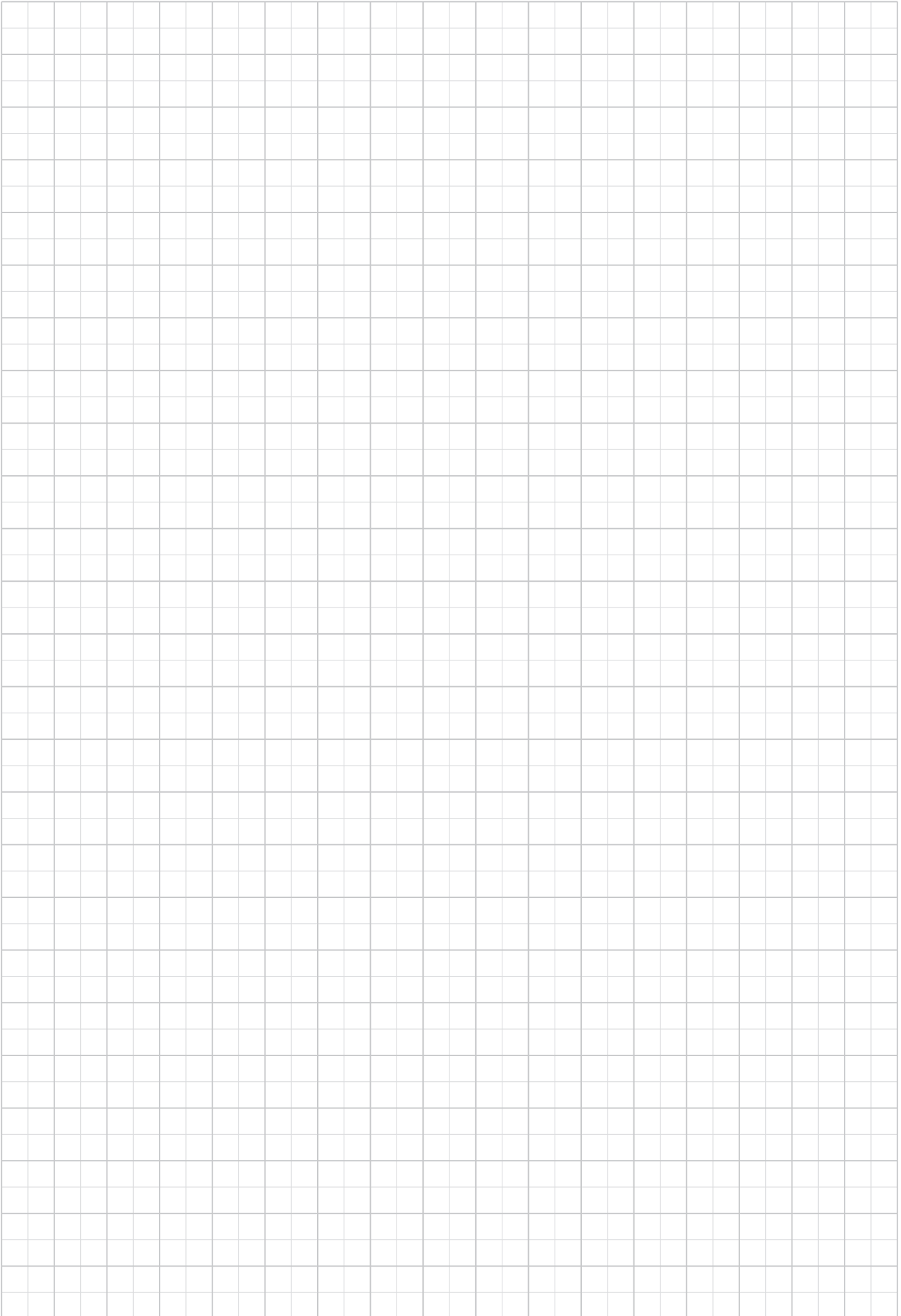
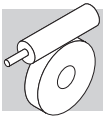

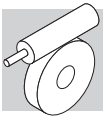

VF 250...P (IEC)

A

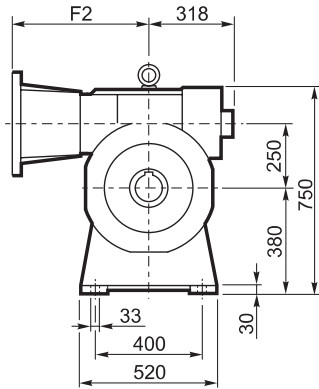
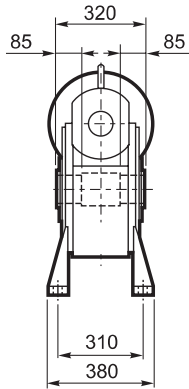

N

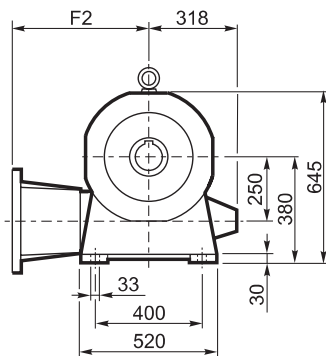
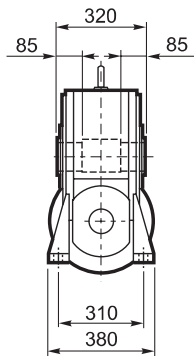

INPUT

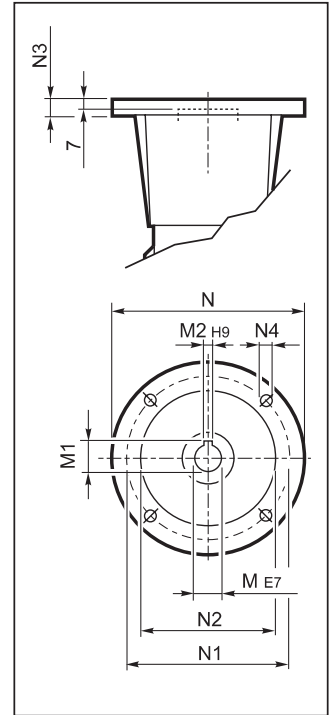

OUTPUT

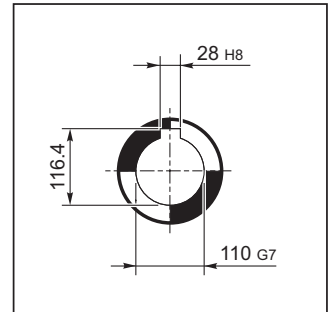

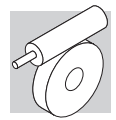

VF 250...P (IEC)

V

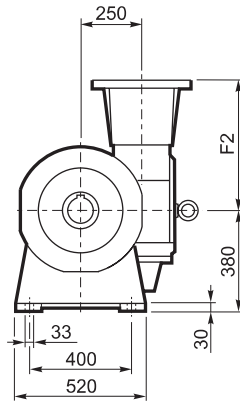
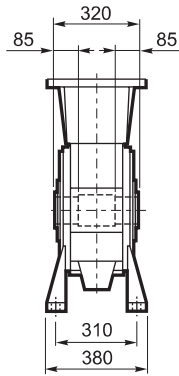

P

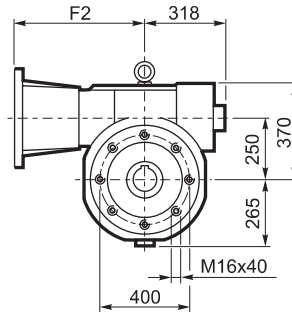
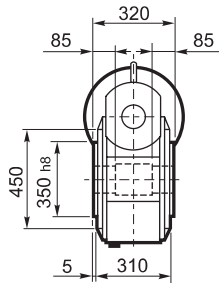

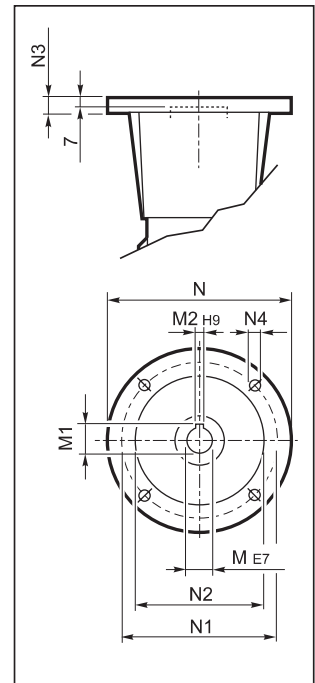

INPUT

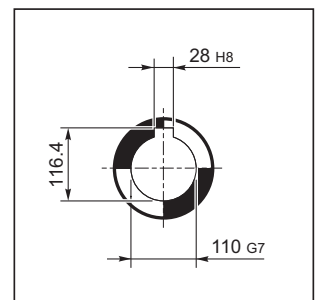

OUTPUT



Dans les formes de construction A et P, il est prévu un ventilateur de refroidissement.
 Dans la version P(IEC), la fourniture du joint complet d'accouplement moteur à été prévue de série.

		F2	M	M1	M2	N	N1	N2	N3	N4	
VF 250	P132 B5	531	38	41.3	10	300	265	230	25	M12	310
VF 250	P160 B5	506	42	45.3	12	350	300	250	22	18	
VF 250	P180 B5	506	48	51.8	14	350	300	250	22	18	
VF 250	P200 B5	531	55	59.3	16	400	350	300	25	M16	
VF 250	P225 B5	536	60	64.4	18	450	400	350	22	18#	

N. 8 trous 45°

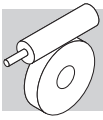

VFR 250...P (IEC)

A

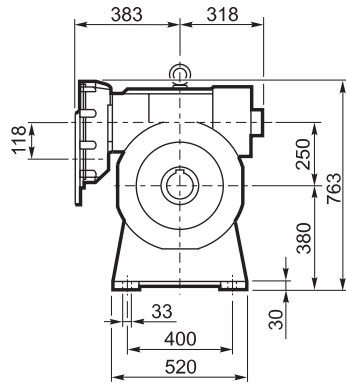
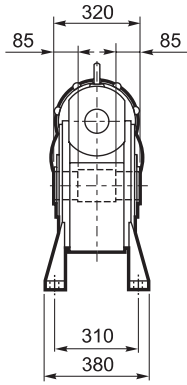

N

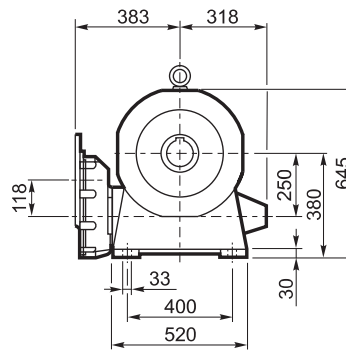
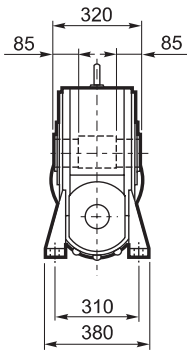

INPUT

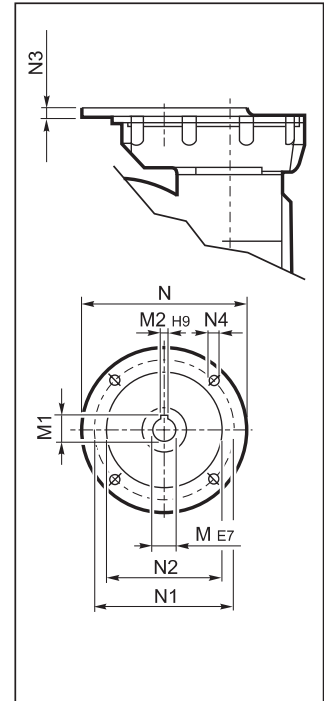

OUTPUT

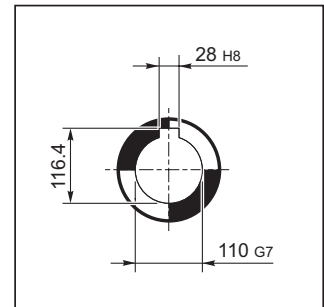

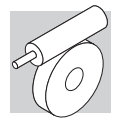

VFR 250...P (IEC)

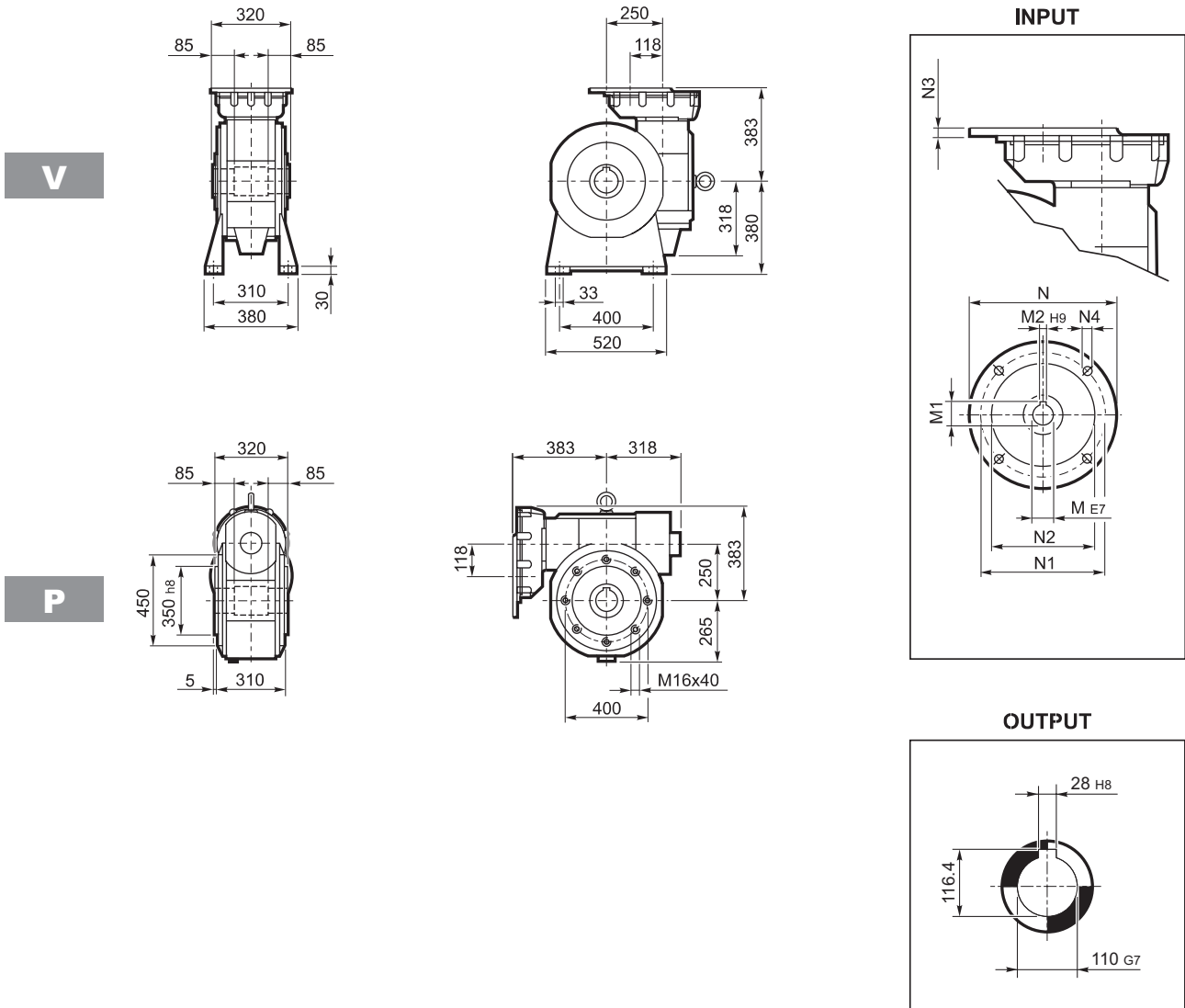

Dans les formes de construction A et P, il est prévu un ventilateur de refroidissement.

		M	M1	M2	N	N1	N2	N3	N4	
VFR 250	P100 B5	28 K6	31.3	8	250	215	180	13	M12x35	295
VFR 250	P112 B5	28 K6	31.3	8	250	215	180	13	M12x35	
VFR 250	P132 B5	38 J6	41.3	10	300	265	230	13	M12x35	
VFR 250	P160 B5	42 J6	44.3#	12	350	300	250	18	M16x60	

Clavette à hauteur réduite

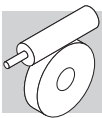

VF/VF 130/250...P (IEC)

A

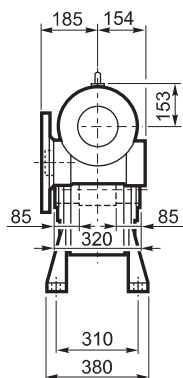
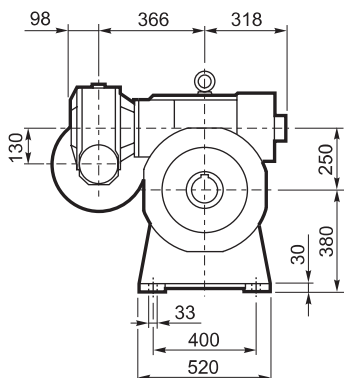

P

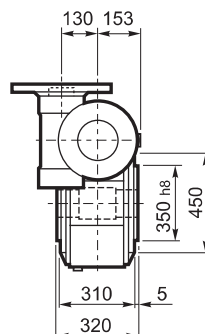
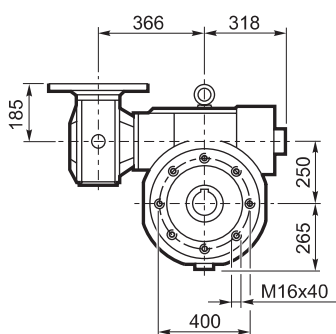

INPUT

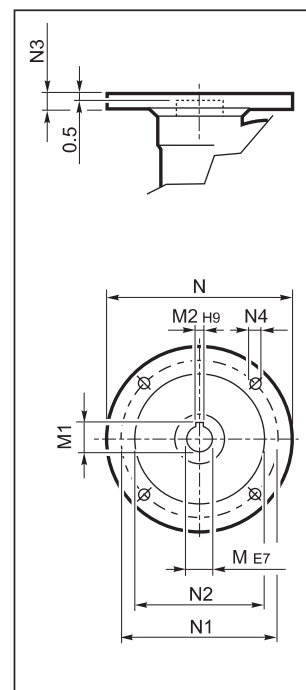

OUTPUT

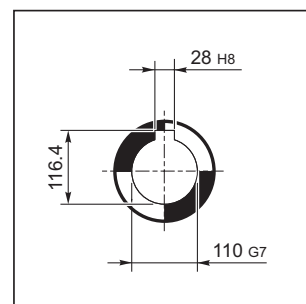

Dans les formes de construction A et P, il est prévu un ventilateur de refroidissement.

		M	M1	M2	N	N1	N2	N3	N4	
VF/VF 130/250	P 90 B5	24	27.3	8	200	165	130	17	11	325
VF/VF 130/250	P100 B5	28	31.3	8	250	215	180	17	13	
VF/VF 130/250	P112 B5	28	31.3	8	250	215	180	17	13	
VF/VF 130/250	P132 B5	38	40.1#	10	300	265	230	17	13	

Clavette à hauteur réduite

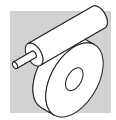

27 DIMENSIONS RÉDUCTEUR AVEC ARBRE RAPIDE CYLLINDRIQUE

VF 27...HS

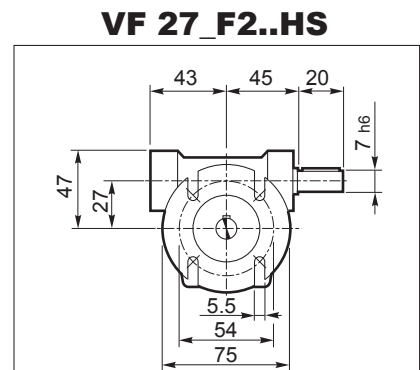
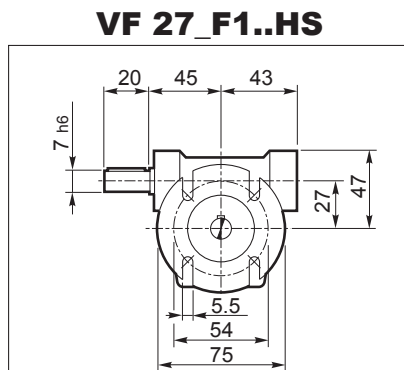
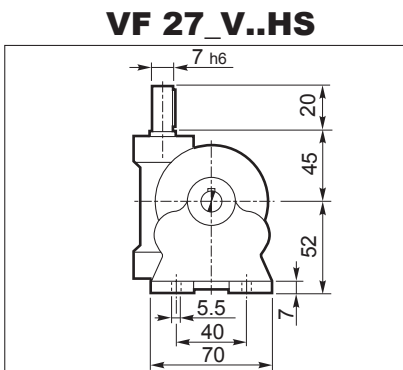
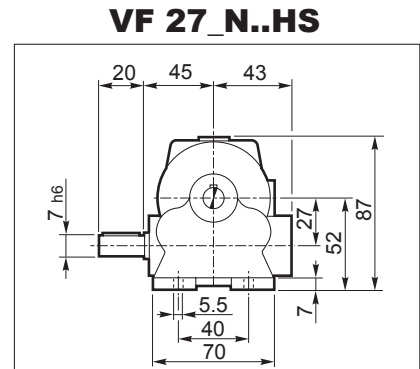
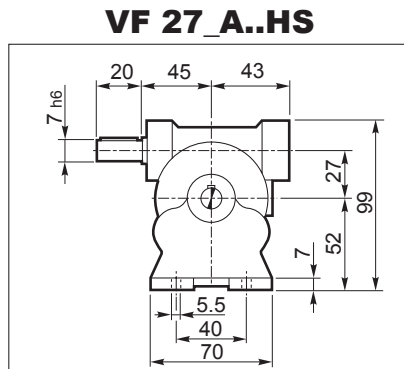
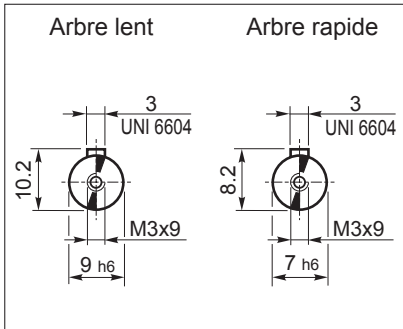

	Kg
VF 27_HS	0.73

Les dimensions communes à toutes les autres configurations sont indiquées à la page 109.

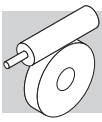

VF...HS - W...HS

VF_A..HS

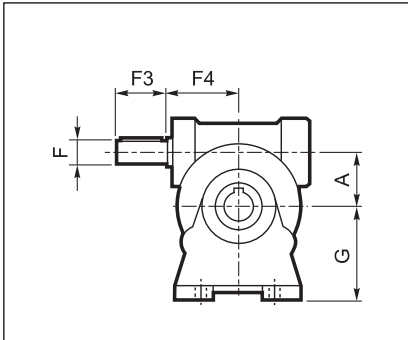

VF_V..HS

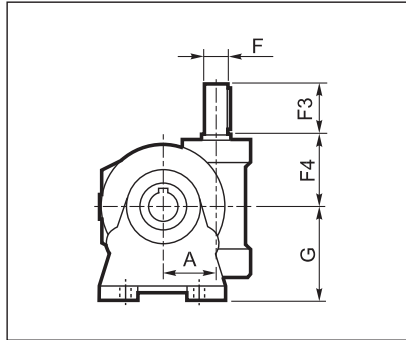

VF_N..HS

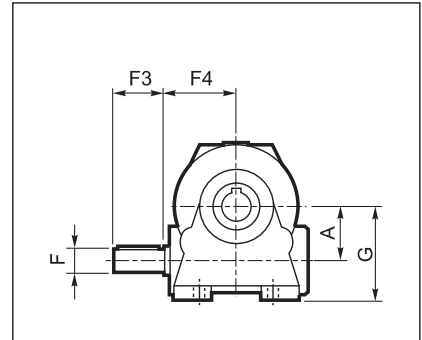

VF_P..HS

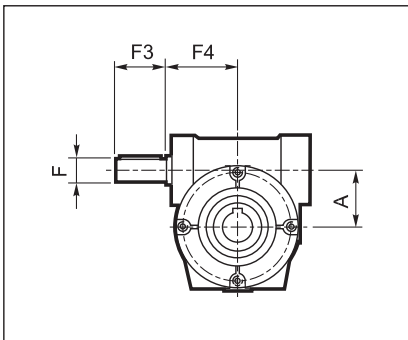

VF_FA/FC/FR/F..HS

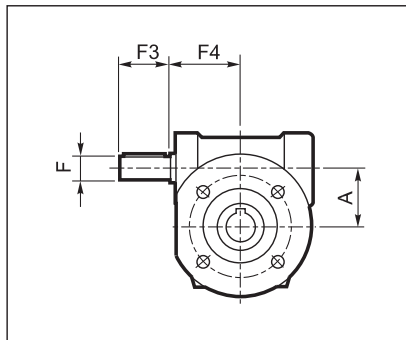

VF_U..HS

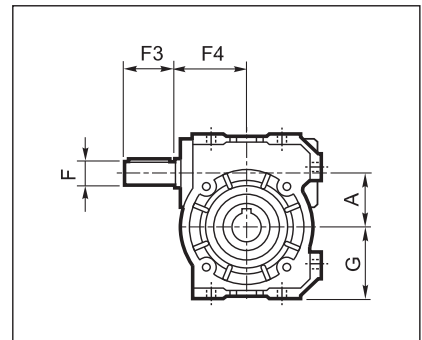

W_U..HS

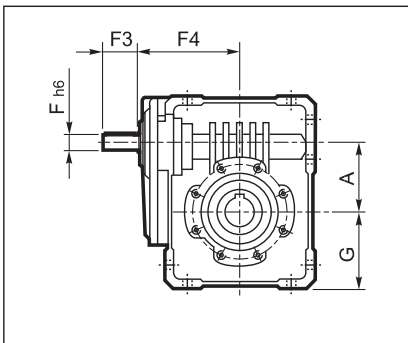

W_UF/UFC/UFCR..HS

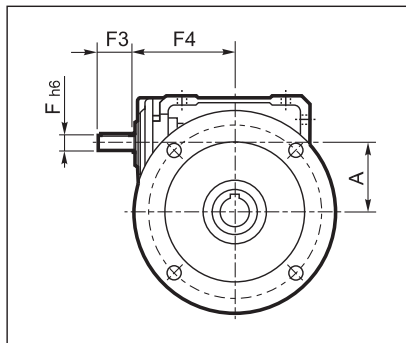

Arbre lent

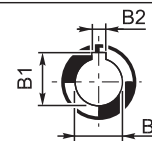

Arbre rapide

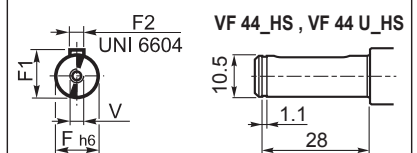

	A	B	B1	B2	F	F1	F2	F3	F4	G	V	kg
VF 30_HS	30	14 H7	16.3	5	9	10.2	3	20	50	55	—	1.1
VF 30_U_HS										47		
VF 44_HS	44.6	18 H7	20.8	6	11	12.5	4	30	54	72	—	2.0
VF 44_U_HS										55		
VF 49_HS	49.5	25 H7	28.3	8	16	18	5	40	65	82	M6x16	3.0
VF 49_U_HS										64.5		
W 63_HS	62.17	25 H7	28.3	8	18	20.5	6	40	110.5	72.5	M6x16	6.4
W 75_HS	75	30(28) H7	33.3(31.3)	8	19	21.5	6	40	128	87	M6x16	10.0
W 86_HS	86.9	35 H7	38.3	10	25	28	8	50	144	100	M8x19	14.1
W 110_HS	110.1	42 H7	45.3	12	25	28	8	60	168	125	M8x19	27
VF 130_HS	130	45 H7	48.8	14	30	33	8	60	160	195	M8x20	49
VF 150_HS	150	50 H7	53.8	14	35	38	10	65	185	220	M8x20	60
VF 185_HS	185.4	60 H7	64.4	18	40	43	12	70	214.5	254	M8x20	94
VF 210_HS	210	90 H7	95.4	25	48	51.5	14	110	230	335	M16x40	175
VF 250_HS	250	110 G7	116.4	28	55	59	16	110	274	380	M16x40	275

Les dimensions communes à toutes les autres configurations sont indiquées de la page 110 jusqu'à 165.

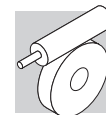

VFR...HS - WR...HS

VFR_A..HS

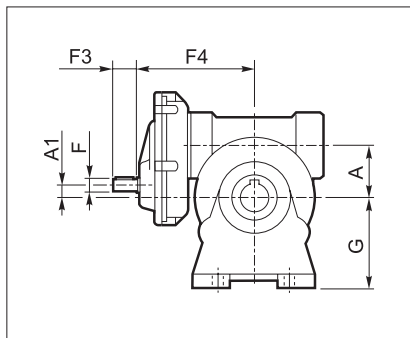

VFR_N..HS

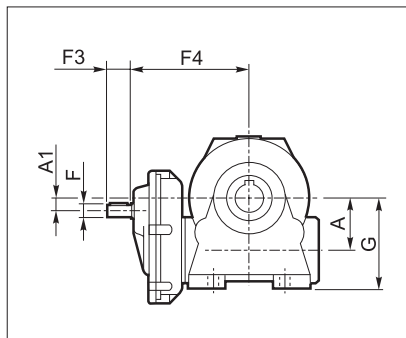

VFR_V..HS

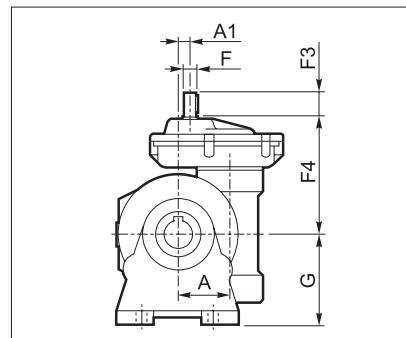

VFR_P..HS

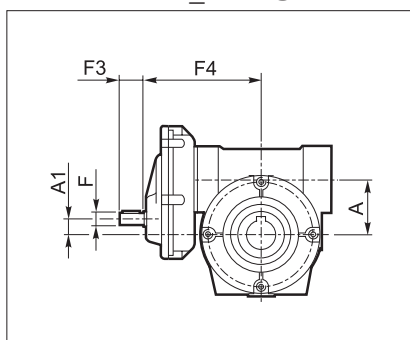

VFR_FA/FC/FR/F..HS

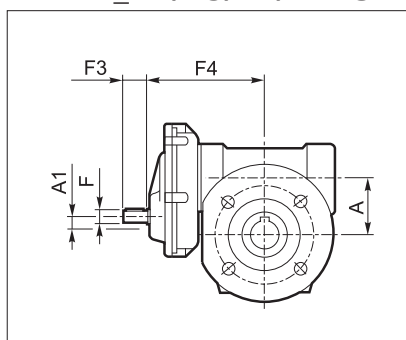

VFR_U..HS

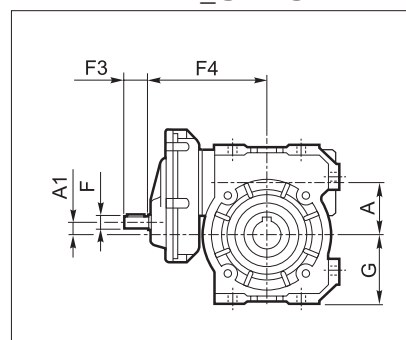

WR_U..HS

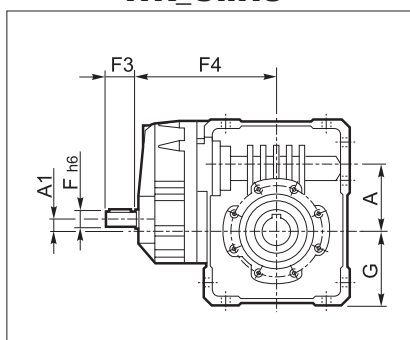

WR_UF/UFC/UFCR..HS

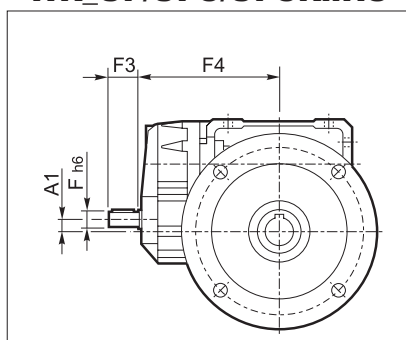

Arbre lent

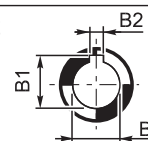

Arbre rapide

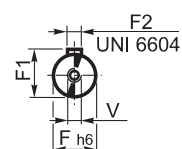

	A	A1	B	B1	B2	F	F1	F2	F3	F4	G	V	
VFR 49_HS	49.5	10	25 H7	28.3	8	11	12.5	4	23	110	82	M4x10	5
VFR 49_U HS											64.5		
WR 63_HS	62.17	11.42	25 H7	28.3	8	14	16	5	30	138	72.5	M5x12.5	7.1
WR 75_HS	75	11	30(28) H7	33.3(31.3)	8	19	21.5	6	40	162	87	M6x16	11.1
WR 86_HS	86.9	22.9	35 H7	38.3	10	19	21.5	6	40	178	100	M6x16	14.7
WR 110_HS	110.1	21.1	42 H7	45.3	12	24	27	8	50	201	125	M8x19	34
VFR 130_HS	130	45	45 H7	48.8	14	24	27	8	50	228	195	M8x20	57
VFR 150_HS	150	53	50 H7	53.8	14	28	31	8	60	280	220	M8x20	71
VFR 185_HS	185.4	88.4	60 H7	64.4	18	28	31	8	60	310	254	M8x20	110
VFR 210_HS	210	92	90 H7	95.4	25	38	41	10	80	335	335	M10x25	185
VFR 250_HS	250	132	110 G7	116.4	28	38	41	10	80	383	380	M10x25	295

Les dimensions communes à toutes les autres configurations sont indiquées de la page 114 jusqu'à 167.

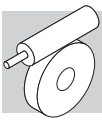

VF/VF...HS - VF/W...HS - W/VF...HS

**VF/VF_A..HS
W/VF_A..HS**

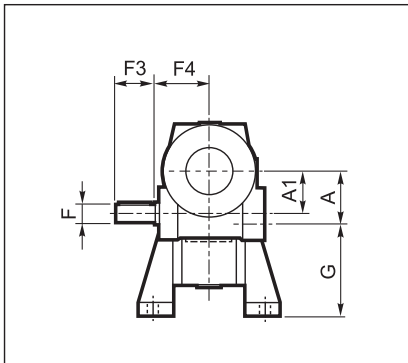

**VF/VF_P..HS
W/VF_P..HS**

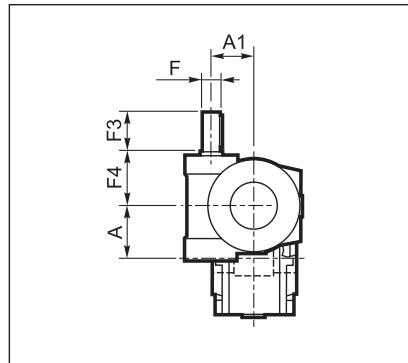

**VF/VF_P..HS
W/VF_P..HS**

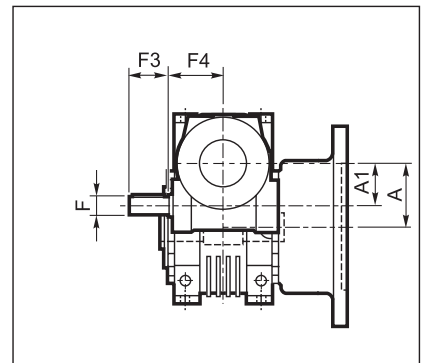
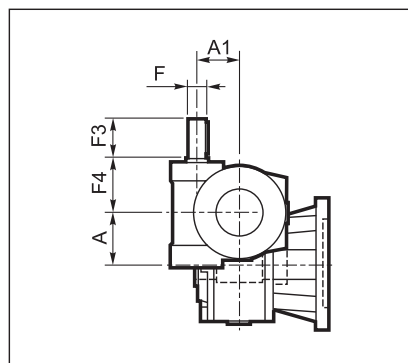
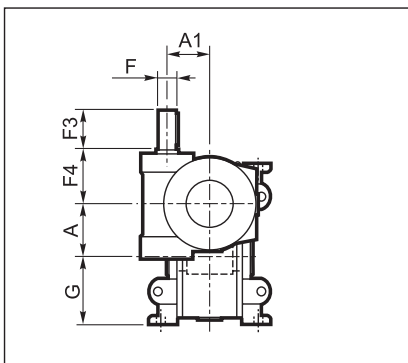
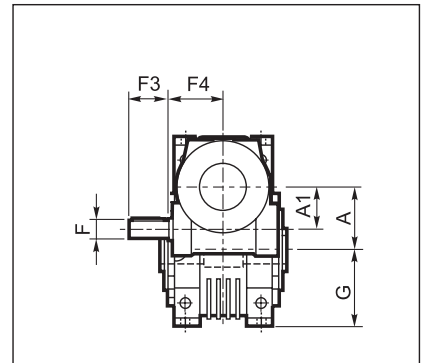

Arbre lent

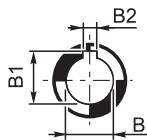

Arbre rapide

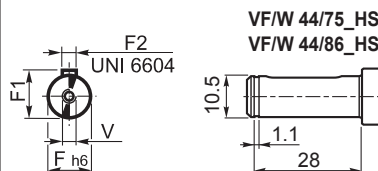

	A	A1	B	B1	B2	F	F1	F2	F3	F4	G	V	Kg
VF/VF 30/44_HS	44.6	30	18 H7	20.8	6	9	10.2	3	20	50	72	—	3.5
VF/VF 30/44 U_HS											55		
VF/VF 30/49_HS	49.5	30	25 H7	28.3	8	9	10.2	3	20	50	82	—	4.5
VF/VF 30/49 U_HS											64.5		
VF/W 30/63_HS	62.17	30	25 H7	28.3	8	9	10.2	3	20	50	100	—	7.5
VF/W 44/75_HS	75	44.6	30 (28) H7	33.3 (31.3)	8	11	12.5	4	30	54	115	—	16.1
VF/W 44/86_HS	86.9	44.6	35 H7	38.3	10	11	12.5	4	30	54	142	—	42
VF/W 49/110_HS	110.0	49.5	42 H7	45.3	12	16	18	5	40	65	170	M6x16	46
W/VF 63/130_HS	130	62.17	45 H7	48.8	14	18	20.5	6	40	110.5	72.5	M6x16	74
W/VF 86/150_HS	150	86.9	50 H7	53.8	14	25	28	8	50	144	100	M8x19	108
W/VF 86/185_HS	185.4	86.9	60 H7	64.4	18	25	28	8	50	144	100	M8x19	109
VF/VF 130/210_HS	210	130	90 H7	95.4	25	30	33	8	60	160	335	M8	225
VF/VF 130/250_HS	250	130	110 G7	116.4	28	30	33	8	60	160	380	M8	325

Les dimensions communes à toutes les autres configurations sont indiquées de la page 110 jusqu'à 168.

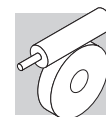

28 ACCESSORIES

28.1 Arbre lent rapporté

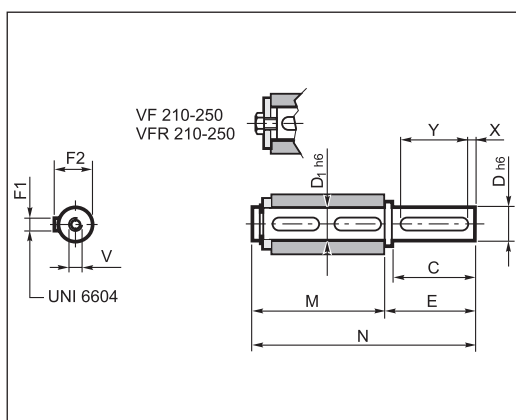

		C	D	D1	E	F1	F2	M	N	V	X	Y
VF	30	30	14	14	35	5	16	61	96	M5x13	5	20
VFR	44	40	18	18	45	6	20.5	70	115	M6x16	5	30
VF/VF	49	60	25	25	65	8	28	89	154	M8x19	5	50
	63	60	25	25	65	8	28	127	192	M8x19	5	50
W	75_D28	60	28	30	65	8	31	134	199	M8x20	5	50
WR	75_D30	60	30	30	65	8	33	134	199	M10x22	5	50
VF/W	86	60	35	35	65	10	38	149	214	M10x22	5	50
	110	75	42	42	80	12	45	164	244	M12x28	7.5	60
	130	80	45	45	85	14	48.5	176	261	M12x32	5	70
VF	150	85	50	50	93	14	53.5	185	278	M16x40	7.5	70
VFR	185	100	60	60	110	18	64	200	310	M16x40	10	80
W/VF	210	130	90	90	140	25	95	255	395	M20x50	5	120
	250	165	110	110	175	28	116	315	490	M24x64	15	140

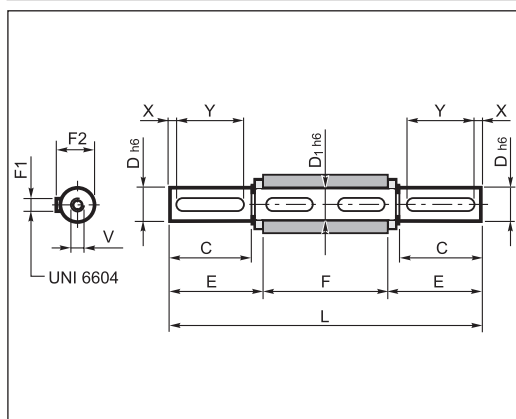

		C	D	D1	E	F	F1	F2	L	V	X	Y
VF	30	30	14	14	32.5	55	5	16	120	M5x13	5	20
VFR	44	40	18	18	42.7	64	6	20.5	149.4	M6x16	5	30
VF/VF	49	60	25	25	63.2	82	8	28	208.4	M8x19	5	50
	63	60	25	25	63.2	120	8	28	246.4	M8x19	5	50
W	75_D28	60	28	30	64	127	8	31	255	M8x20	5	50
WR	75_D30	60	30	30	64	127	8	33	255	M10x22	5	50
VF/W	86	60	35	35	64	140	10	38	268	M10x22	5	50
	110	75	42	42	79.3	155	12	45	313.5	M12x28	7.5	60
	130	80	45	45	84.7	165	14	48.5	334.5	M12x32	5	70
VF	150	85	50	50	90	175	14	53.5	355	M16x40	7.5	70
VFR	185	100	60	60	105	190	18	64	400	M16x40	10	80
W/VF	210	130	90	90	140	260	25	95	540	M20x50	5	120
	250	165	110	110	175	320	28	116	670	M24x64	15	140

28.2 Bras de réaction

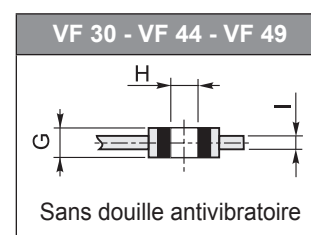
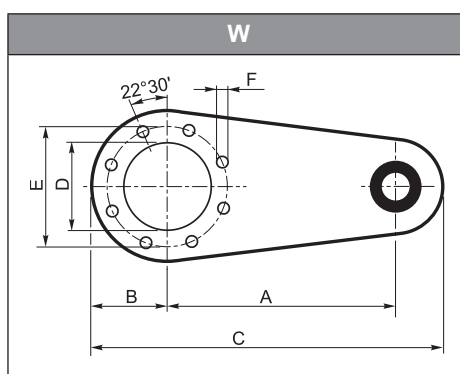
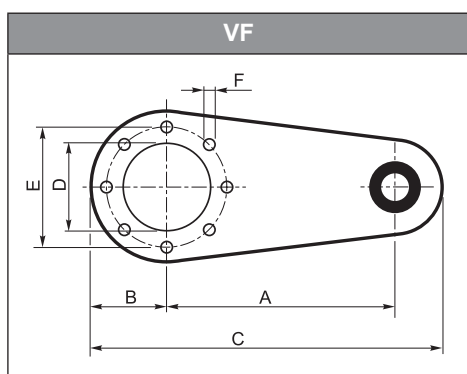

		A	B	C	D	E	F	G	H	I
VF	30	100	40	157.5	50	65	7	14	8	4
VFR	44	100	40	157.5	50	65	7	14	8	4
VF/VF	49	100	55	172.5	68	94	7	14	8	4
	63	150	55	233	75	90	9	20	10	6
W	75	200	63	300	90	110	9	25	20	6
WR	86	200	80	318	110	130	11	25	20	6
VF/W	110	250	100	388	130	165	13	25	20	6
	130	300	125	470	180	215	13	30	25	6
VF	150	300	125	470	180	215	15	30	25	6
VFR	185	350	150	545	230	265	17	30	25	6
W/VF	210	350	175	625	250	300	19	60	50	8
	250	400	225	725	350	400	19	60	50	10

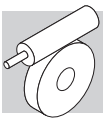

28.3 Kit pieds KA, KV

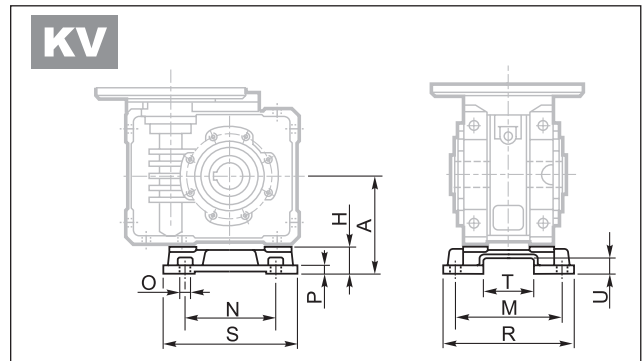
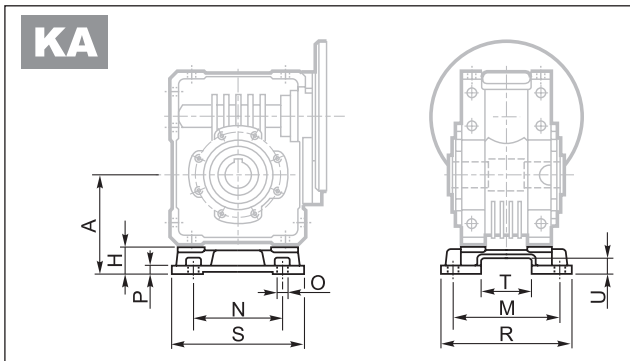

	A	H	M	N	O	P	R	S	T	U
W 63 - WR 63	100	27.5	111	95	11	8	135	145	56.5	15.5
W 75 - WR 75	115	28	115	120	11	9	139	174	56.5	15.5
W 86 - WR 86	142	42	146	140	11	11	170	200	69	20
W 110 - WR 110	170	45	181	200	13	14	210	250	69	20

28.4 Capuchon de protection

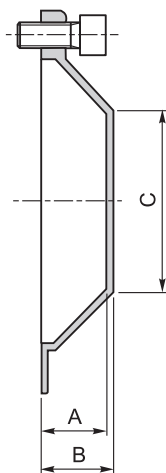

	A	B	C
W 63 - WR 63	26.5	29	Ø35
W 75 - WR 75	24.5	27	Ø54
W 86 - WR 86	26.5	29	Ø71
W 110 - WR110	27.5	30	Ø89

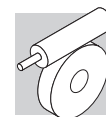

29 ARBRE MACHINE

Pour la réalisation de l'arbre mené d'accouplement avec le réducteur, nous conseillons d'utiliser de l'acier de bonne qualité et de respecter les dimensions indiquées sur le schéma suivant.

Il est également proposé de compléter l'assemblage avec un dispositif de blocage axial de l'arbre, par exemple comme illustré ce qui suit, en veillant de vérifier et de dimensionner les différents composants en fonction des besoins des différentes applications.

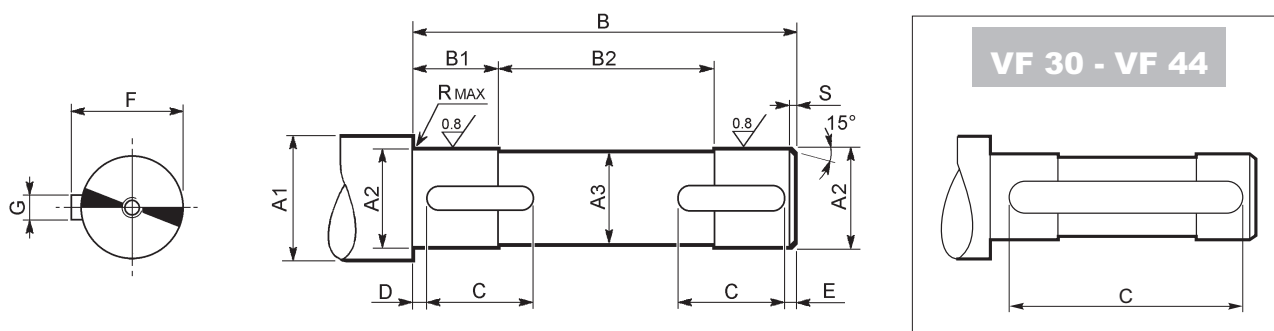

	A1	A2	A3	B	B1	B2	C	D	E	F	G	R	S	 UNI 6604
VF 30	≥ 19	14 f7	13	53	18.5	16	40	6.5	6.5	16	5 h9	0.5	1.5	5x5x40 A
VF 44	≥ 23	18 f7	17	62	22.5	17	50	6	6	20.5	6 h9	0.5	1.5	6x6x50 A
VF 49	≥ 30	25 f7	24	80	20.5	39	20	2	2	28	8 h9	1	1.5	8x7x20 A
W 63	≥ 30	25 f7	24	118	38	42	35	2	2	28	8 h9	1	1.5	8x7x35 A
W 75	≥ 35	28 f7	27	125	38	49	40	2	2	31	8 h9	1	1.5	8x7x40 A
	≥ 35	30 f7	29	125	38	49	40	2	2	33	8 h9	1	1.5	8x7x40 A
W 86	≥ 42	35 f7	34	138	43	52	40	2	2	38	10 h9	1.5	1.5	10x8x40 A
W 110	≥ 48	42 f7	41	153	43	67	50	2	2	45	12 h9	1.5	2	12x8x50 A
VF 130	≥ 52	45 f7	44	163	50.5	62	60	2.5	2.5	49.5	14 h9	2.5	2	14x9x60 A
VF 150	≥ 57	50 f7	49	173	53	67	70	2.5	2.5	53.5	14 h9	2.5	2	14x9x70 A
VF 185	≥ 68	60 f7	59	188	63	62	80	2.5	2.5	64	18 h9	2.5	2	18x11x80 A
VF 210	≥ 99	90 f7	89	258	83	92	80	3	3	95	25 h9	2.5	2.5	25x14x80 A
VF 250	≥ 121	110 h7	109	318	83	152	80	3	3	116	28 h9	2.5	2.5	28x16x80 A

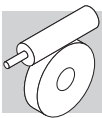

30 LIMITER DE COUPLE

30.1 Description

Le limiteur de couple à friction, étudié et réalisé pour les réducteurs à vis sans fin, type **VF44 - VF49** et **W63...W110**, est un dispositif de sécurité qui a pour but de protéger la chaîne cinématique des surcharges accidentelles qui pourraient endommager tous les éléments de la transmission.

Par rapport au montage du limiteur de couple traditionnel à l'extérieur du réducteur, cette solution, d'une grande souplesse d'emploi, offre les avantages suivants:

- aucune différence des cotes d'encombrement par rapport au réducteur standard
- aucun entretien, car le système fonctionne en bain d'huile
- le couple maximum transmissible peut être facilement ajusté par une manoeuvre simple à l'extérieur du réducteur
- le glissement, même continu, ne crée aucun dommage ni usure aux parties mécaniques, du fait de la séparation des surfaces en glissement par un film d'huile d'épaisseur constante.



Son utilisation dans des mécanismes de levage est déconseillée.

30.2 Mode de fonctionnement

Le limiteur de couple fonctionne comme une friction bi-conique entre des surfaces de contact obtenues directement sur la couronne en bronze, un moyeu en fonte à graphite sphéroïdal GS400/12 monolithique et un arbre de sortie creux traversant, permettant une liaison directe à la machine.

Les surfaces coniques sont maintenues en pression par un effort axial constant, généré par les rondelles élastiques.

Le réglage du couple de glissement s'effectue d'une façon simple à travers le serrage d'un écrou extérieur au réducteur.

30.3 Protection de l'installation contre les surcharges:

Le limiteur, correctement réglé au couple nécessaire pour la machine protège tous les organes mécaniques de la chaîne cinématique, en évitant des endommagements dus à d'éventuelles et répétitives surcharges.

30.4 Décrabotage en cas d'irréversibilité

Dans certaines applications, il peut être utile de faire tourner, machine arrêtée, l'arbre lent du réducteur. Cette solution n'est pas toujours possible avec les réducteurs à roue est vis sans fin traditionnels. A l'aide de ce dispositif, en desserrant l'écrou de réglage, il est possible de procéder facilement à cette opération.

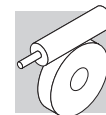

30.5 VF...L, W...L

L1								L2								
	N	A	V	U	F1 FC1 FR1 FA1	F2 FC2 FR2 FA2**	P1 P2		N	A	V	U	F1 FC1 FR1 FA1**	F2 FC2 FR2 FA2	P1 P2	
VF VF/VF*									VF VF/VF*							
	U	UF1 UFC1	UF2 UFC2	UFCR1	UFCR2				U	UF1 UFC1	UF2 UFC2	UFCR1	UFCR2			
W VF/W*									W VF/W*							

* Dans les réducteurs combinés VF/VF, le limiteur de couple en position L1 et L2 est monté sur le 2me réducteur, en position LF il est monté sur le 1er réducteur.

LF				
	VF/W	44/75	44/86	49/110
	W/VF	63/130	86/150	86/185

En standard et en l'absence d'information précise, les réducteurs VF...L seront livrés avec le système de débrabotage à gauche (L1), vue se plaçant du côté du moteur électrique.

30.6 Dimensions

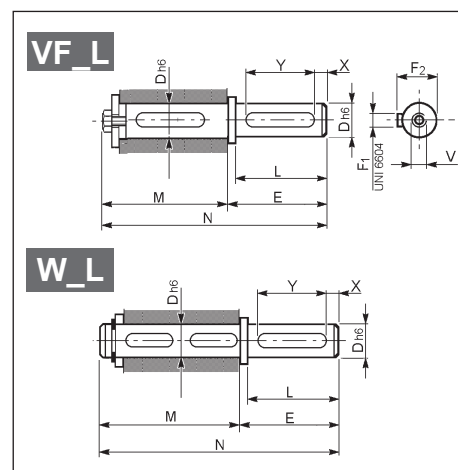
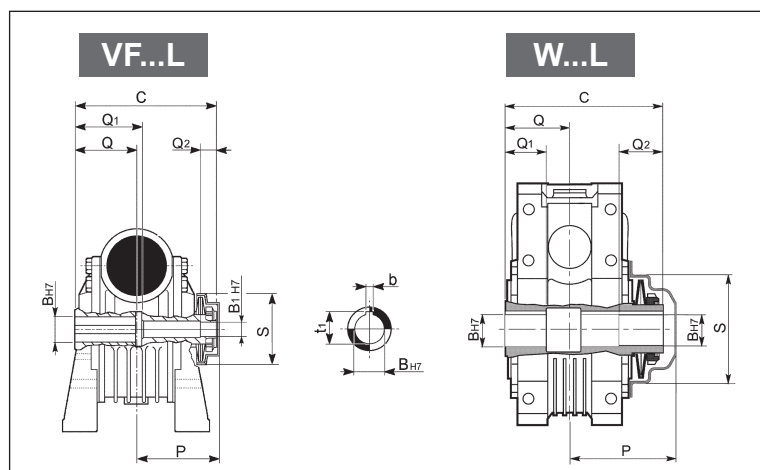

	Limiteur de couple										Arbre lent unilatéral									
	C	Q	Q1	Q2	P	S	B _{H7}	B _{1H7}	t ₁	b	L	D _{h6}	E	F1	F2	M	N	V	X	Y
VF 44L	79	32	32	12	48	42.5	18	11	20.8	6	40	18	45	6	20.5	86	131	M6x16	5	30
VF 49L	105	41	51	15	63.5	66.5	25	14	28.3	8	60	25	65	8	28	114.5	179.5	M8x19	5	40
W 63L	145	60	40	40	100	77	25	-	28.3	8	60	25	65	8	28	152	217	M8x19	5	50
W 75L_D30	154.5	63.5	40	40	104	100	30	-	33.3	8	60	30	65	8	33	161.5	226.5	M10x22	5	50
W 86L	170	70	50	45	113	119	35	-	38.3	10	60	35	65	10	38	179	244	M10x22	5	50
W 110L	191	77.5	55	45	133	134	42	-	45.3	12	75	42	80	12	45	200	280	M12x28	7.5	60

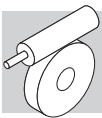

30.7 Réglage du couple de glissement

Un pré-tarage du couple de glissement sur la base d'un moment de torsion coïncidant avec la valeur du couple nominal Mn_2 [$n_1=1400$] du réducteur type VF ou W est effectué en usine.

Ci-après sont décrites les opérations effectuées en usine pour réaliser le tarage du couple de glissement. Les mêmes opérations, sauf l'étape 2, devront être effectuées si l'on veut obtenir un couple différent de celui prévu à l'origine.

1. L'écrou de réglage est vissé jusqu'à ce que les rondelles élastiques soient suffisamment précontraintes et ne puissent plus tourner librement par une action manuelle.
2. Au moyen d'un marqueur on réalise deux repères dans la même position angulaire, l'un sur l'écrou et l'autre sur la saillie de l'arbre lent. Cette position de référence constituera le point de départ pour le décompte des tours successifs de la bague et en conséquence le tarage du couple.
3. En final, la bague est vissée des fractions de tours correspondant à la valeur du couple nominal Mn_2 du réducteur concerné. La référence dans ce cas est le diagramme ci-dessous, lequel servira également pour les éventuels réglages qui s'avèreraient nécessaires dans le temps.

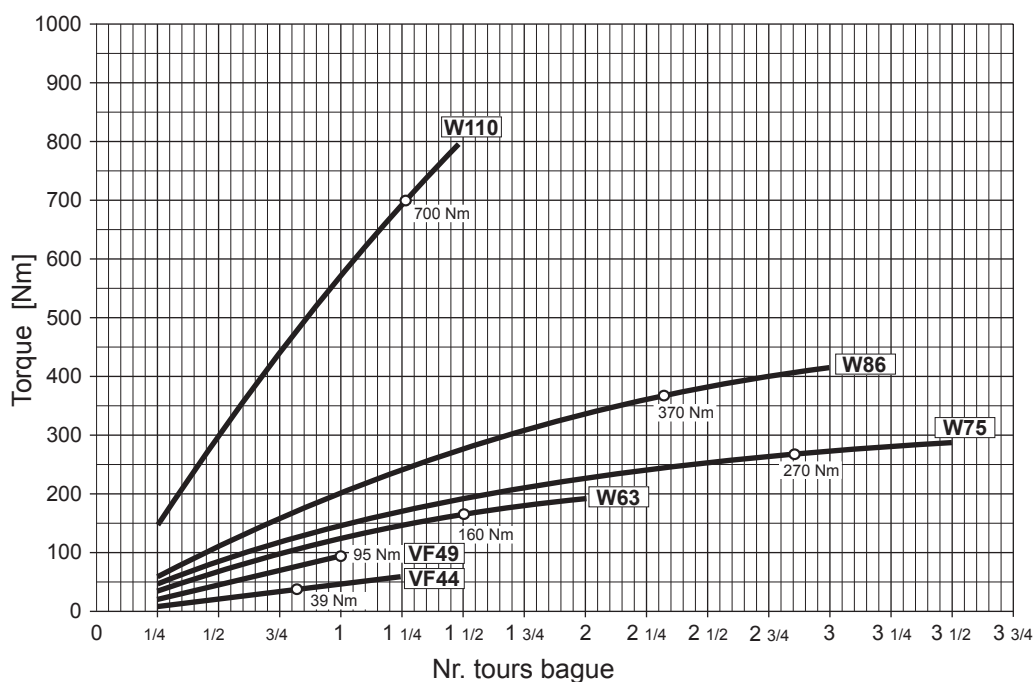

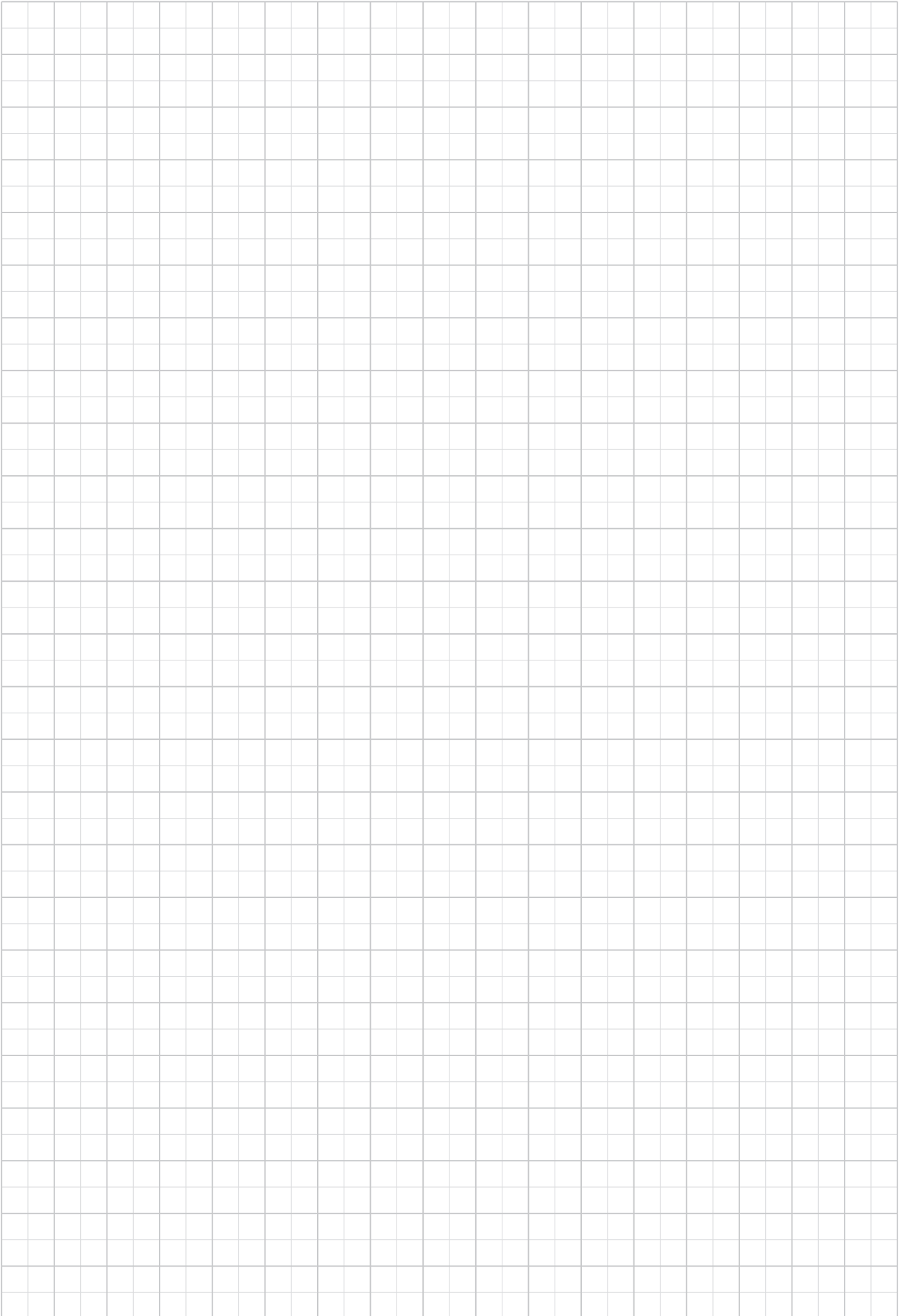
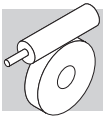

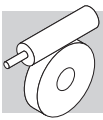

VF-EP / W-EP - RÉDUCTEURS ET MOTORÉDUCTEURS POUR LES ENVIRONNEMENTS CORROSIFS ET ASEPTIQUES

31 LES AVANTAGES DE L'EXÉCUTION EP POUR L'INDUSTRIE ALIMENTAIRE

Les industries des secteurs de la boisson et alimentaire ont aujourd'hui à leur disposition une gamme de motoréducteurs expressément étudiés pour leurs exigences spécifiques et habituellement introuvables dans les productions de série. Le réducteur rigoureusement hermétique et le nettoyage hygiéniquement parfait de ses surfaces permettent son installation même à proximité du processus de traitement, sans qu'il soit nécessaire d'installer d'autres écrans ou carters.

Le système époxy de protection des surfaces externes, d'une épaisseur totale d'environ 200 µm fournit d'excellentes qualités de résistance mécanique à l'abrasion.

Le groupe complet, réducteur ou motoréducteur, est protégé à l'aide d'un système réalisé à partir d'une couche d'apprêt puis d'une couche de finition, exemptes de plomb et de chrome. Les produits utilisés sont approuvés par la FDA et la NSF (en fonction de la teinte choisie) et certifiés par des laboratoires indépendants comme adaptés au contact accidentel avec les aliments, en plus d'assurer une protection spéciale aux attaques de nombreux acides, liquides alcalins et solvants, sprays et détergents utilisés le plus fréquemment lors des nettoyages chimiques.

Selon les termes de la norme ISO 9223, le système de peinture adopté est adapté pour les environnements les plus agressifs, c'est-à-dire se trouvant en classe C5.

Disponibles dans trois coloris différents, identifiés par les sigles RAL 9010 (blanc), 5010 (bleu) et 9006 (gris clair métallisé). Le produit série **EP** peut ensuite être configuré avec une vaste série d'options et accessoires pour le montage.

Tailles de réducteur : 44 (sauf VFR), 49, 63, 75, 86. Motorisations disponibles : de 0,12 à 4 kW, en exécution tant compacte que selon la norme CEI 2, 4 et 6 pôles.

Idéaux pour les industries alimentaires





Résistants à la corrosion



Service adapté aux environnements les plus hostiles

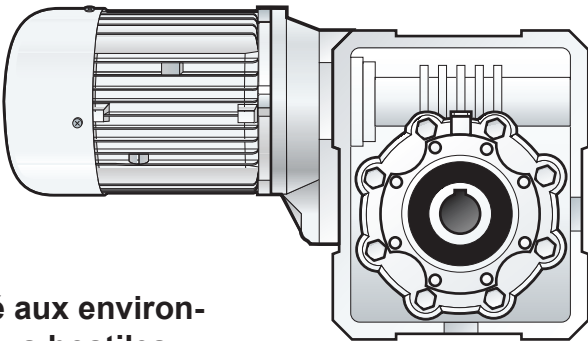

Lavables/faciles à hygiéniser avec les détergents les plus utilisés habituellement



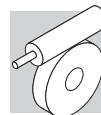

EQUIPEMENT POUR LE RÉDUCTEUR

- ① Le réducteur est entièrement scellé afin de minimiser toute contamination possible de l'environnement extérieur.
- ② Arbre lent creux réalisé en acier inoxydable AISI 316.
- ③ Plaquette d'identification et vis en acier inoxydable.
- ④ Orifices pour le drainage de l'eau. Evitent la stagnation après le lavage.
- ⑤ A la place du lubrifiant normal, une option huile synthétique en classe UH1, compatible avec le contact accidentel avec les aliments, est disponible.

- ⑥ Bagues d'étanchéité avec ressort interne en acier inox. Disponibilité de joints d'étanchéité en PTFE avec blindage en inox, résistants aux lavages sous pression.
- ⑦ Le traitement des surfaces externes avec couche de fond et laque de finition époxy à deux composants, approuvée FDA et NSF (en fonction de la teinte choisie) pour le contact accidentel avec les aliments, fournit aussi une excellente résistance chimico-physique contre l'abrasion et l'attaque de nombreux agents chimiques et détergents. Disponible en blanc, bleu et gris clair.
- ⑧ Fermeture des orifices filetés non utilisés par des bouchons à pression.

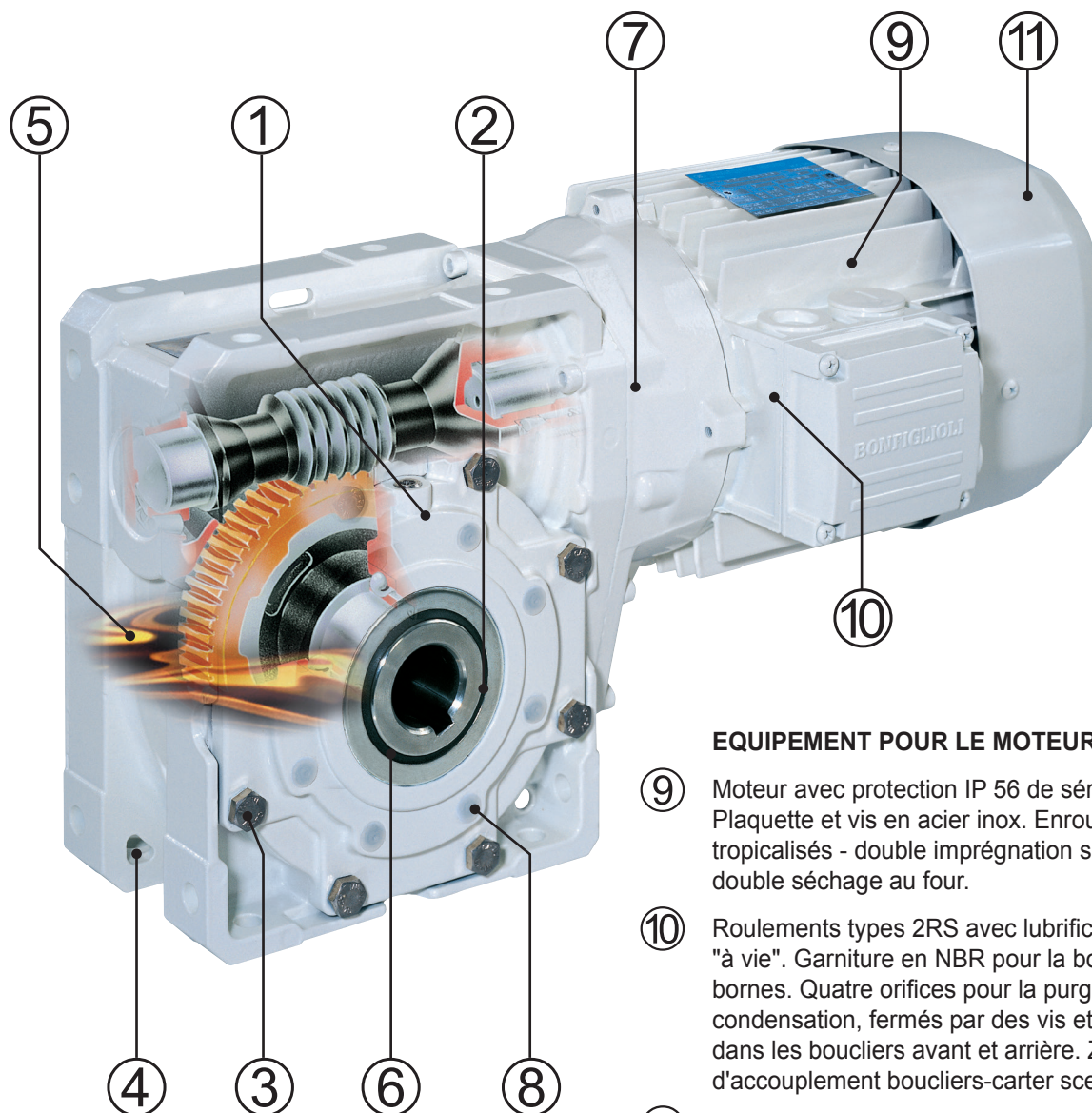

EQUIPEMENT POUR LE MOTEUR

- ⑨ Moteur avec protection IP 56 de série. Plaquette et vis en acier inox. Enroulements tropicalisés - double imprégnation suivie d'un double séchage au four.
- ⑩ Roulements types 2RS avec lubrification "à vie". Garniture en NBR pour la boîte à bornes. Quatre orifices pour la purge de la condensation, fermés par des vis et réalisés dans les boucliers avant et arrière. Zones d'accouplement boucliers-carter scellés.
- ⑪ Ventilateur de refroidissement en polyamide, compatible avec les aliments.

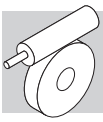

REDUCTEUR

W-EP — 63 U 30 P90 B14 B3 RAL9010

OPTIONS

PEINTURE

NP Sans la peinture	
RAL9010	
RAL5010	
RAL9006 (non homologable pour FDA et NSF)	

POSITION DE MONTAGE

VF-EP 44 VF-EP 49	B3
W-EP 63 W-EP 75 W-EP 86	B3 (default), B6, B7, B8, V5, V6

FORME DE CONSTRUCTION DU MOTEUR
B5, B14 (IEC standard)

DESIGNATION ENTREE

	VF-EP	VF-EP R	W-EP	W-EP R
P(IEC)	 P63...P80	 P63	 P71...P112	 P63...P90
s_			 S1...S3	

RAPPORT DE REDUCTION

FORME DE CONSTRUCTION

TAILLE REDUCTEUR
VF-EP: **44, 49**
W-EP: **63, 75, 86**

— (blank)
R (pre-étage hélicoïdal VF-EP 44)

TYPE REDUCTEU

VF-EP
W-EP

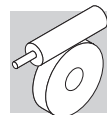



MOTEUR

BN-EP 80B 4 B14 230/400-50 CLF ... RAL9010

OPTIONS

PEINTURE

NP Sans la peinture	
RAL9010	
RAL5010	
RAL9006 (non homologable pour FDA et NSF)	

POSITION BOITE A BORNES
W (default), **N, E, S**

CLASSE ISOLATION
CL F standard
CL H option

TENSION - FREQUENCE

FORME DE CONSTRUCTION
— (moteur compact)
B5, B14 (moteur IEC)

Nbre POLES
2, 4, 6,

TAILLE MOTEUR
1SC ... 3LC (moteur compact)
63 ... 112 (moteur IEC)

TYPE MOTEUR
M-EP = 3 phasé compact
BN-EP = 3 phasé IEC

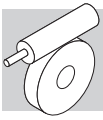

33 OPTIONS REDUCTEURS

PX

Option bagues d'étanchéité arbre lent. Les bagues d'étanchéité spéciales proposées en option étendent l'utilisation des réducteurs aux processus au cours desquels les lavages avec des jets d'eau sous pression sont fréquents.

Le blindage extérieur en acier INOX et la réalisation à double lèvre ajoutent à la fonctionnalité de base une résistance à la pression externe tandis que le matériau particulier utilisé (PTFE) garantit une exceptionnelle résistance aux agents chimiques agressifs, un faible coefficient de frottement et une grande longévité.

PV

Bagues d'étanchéité en élastomère fluoré sur arbre de sortie. Ressort interne en acier inoxydable.

UH1

Option huile compatible avec les aliments. Le réducteur est lubrifié en usine à l'aide d'un lubrifiant "long life", approuvé pour un contact accidentel avec les aliments et enregistré comme UH1 par la NSF pour les industries alimentaires et pharmaceutiques, il satisfait également la norme FDA 21 CFR Sec. 178.3570.

Sa nature synthétique à base de polyglycols, outre à en permettre l'utilisation dans une large plage de température (de -25°C à + 150°C), ne nécessite pas de vidange périodique, par conséquent, en l'absence d'agents contaminants, le lubrifiant est à considérer "à vie".

PREUVES DOCUMENTAIRES

AC - Certificat de conformité

Document dont la délivrance atteste de la conformité du produit à la commande et de la construction de celui-ci conformément aux procédures standard de traitement et de contrôle prévues par le système de Qualité Bonfiglioli Riduttori.

CC - Certificat de réception

La spécification implique la réalisation de vérifications de conformité à la commande, des contrôles visuels généraux et des vérifications instrumentales des dimensions d'accouplement. En outre, des contrôles généraux de fonctionnement à vide et des vérifications de la fonctionnalité des joints d'étanchéité sont réalisés de façon statique et en fonctionnement. La vérification s'applique à un échantillon statistique du lot d'expédition.

34 OPTIONS MOTEURS

Les options disponibles pour les moteurs BN-EP et M-EP sont : D3, E3, K1, H1, NH1, RC, RV, ACM, CC, CUS, S2, S3, S9.

Pour plus d'informations sur les options, consulter les chapitres correspondants dans la section Moteurs électriques.

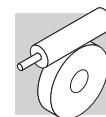

35 AUTRES INFORMATIONS CONCERNANT LES REDUCTEURS ET MOTOREDUCTEURS

Les positions de montage, et les données techniques, les prédispositions moteur, les moments d'inertie et les dimensions des réducteurs **VF-EP** et **W-EP** ne changent pas en comparaison aux produits équivalents des séries **VF** et **W**. De la même façon, les informations relatives aux moteurs **M-EP** et **BN-EP** ne changent pas en comparaison aux produits des séries **M** et **BN**. Toutes ces informations peuvent être retrouvées dans les chapitres relatifs de ce catalogue.

36 LES ACCESSOIRES DE LA SÉRIE EP

En fonction des nécessités d'application, des accessoires déterminés complétant l'architecture du produit sont disponibles, et plus particulièrement :

- arbre lent, tant simple que bilatéral, en acier INOX type 316, avec clavette dans le même matériau
- bras de réaction en tôle peinte (spécifier RAL)
- couvercle de sécurité pour la zone arbre lent (creux) en plastique (W63, W75 et W86) ou en tôle recouverte en gomme NBR (VF44, VF 49) avec vis en acier INOX et degré de protection total IP56.

36.1 Arbre lent rapporté

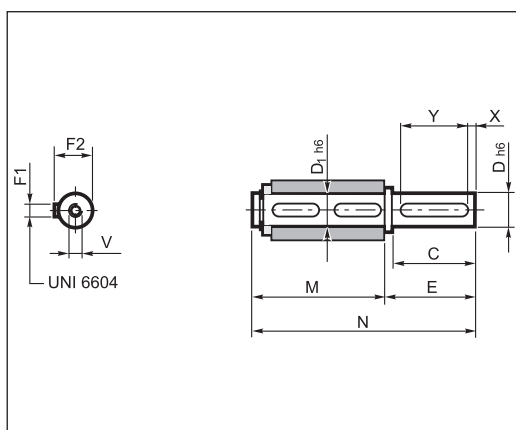

	C	D	D1	E	F1	F2	M	N	V	X	Y
VF-EP 44	40	18	18	45	6	20.5	70	115	M6x16	5	30
VF-EP 49 VF-EP R 49	60	25	25	65	8	28	89	154	M8x19	5	50
W-EP 63 W-EP R 63	60	25	25	65	8	28	127	192	M8x19	5	50
W-EP 75 W-EP R 75	60	30	30	65	8	33	134	199	M10x22	5	50
W-EP 86 W-EP R 86	60	35	35	65	10	38	149	214	M10x22	5	50

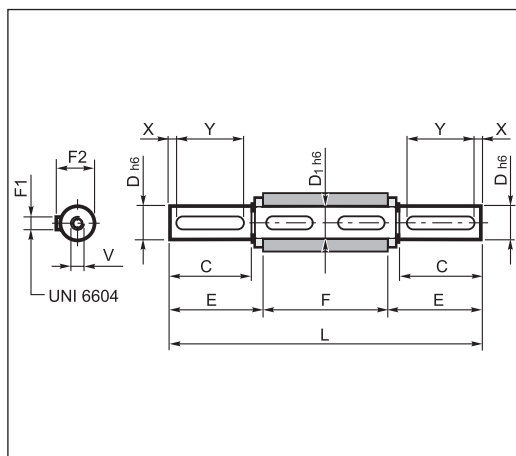

	C	D	D1	E	F	F1	F2	L	V	X	Y
VF-EP 44	40	18	18	42.7	64	6	20.5	149.4	M6x16	5	30
VF-EP 49 VF-EP R 49	60	25	25	63.2	82	8	28	208.4	M8x19	5	50
W-EP 63 W-EP R 63	60	25	25	63.2	120	8	28	246.4	M8x19	5	50
W-EP 75 W-EP R 75	60	30	30	64	127	8	33	255	M10x22	5	50
W-EP 86 W-EP R 86	60	35	35	64	140	10	38	268	M10x22	5	50

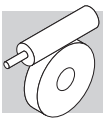

36.2 Bras de réaction

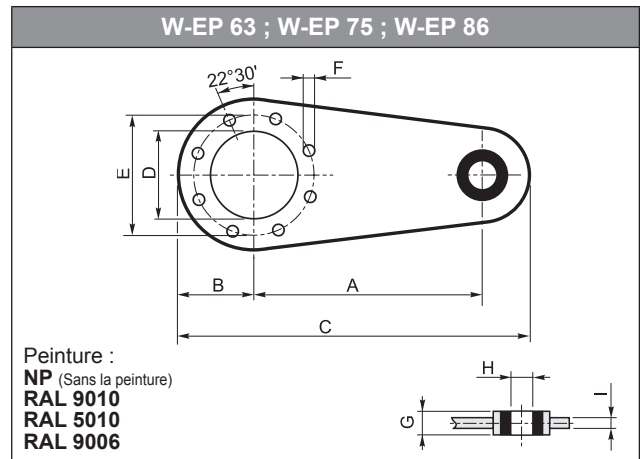
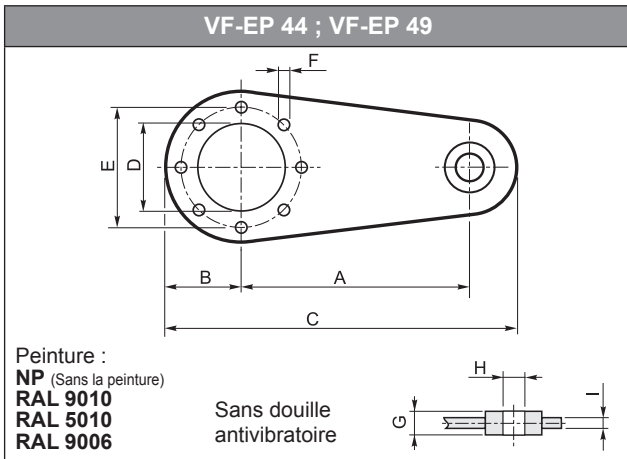

	A	B	C	D	E	F	G	H	I
VF-EP 44	100	40	157.5	50	65	7	14	8	4
VF-EP 49 VF-EP R 49	100	55	172.5	68	94	7	14	8	4
W-EP 63 W-EP R 63	150	55	233	75	90	9	20	10	6
W-EP 75 W-EP R 75	200	63	300	90	110	9	25	20	6
W-EP 86 W-EP R 86	200	80	318	110	130	11	25	20	6

36.3 Capuchon de protection

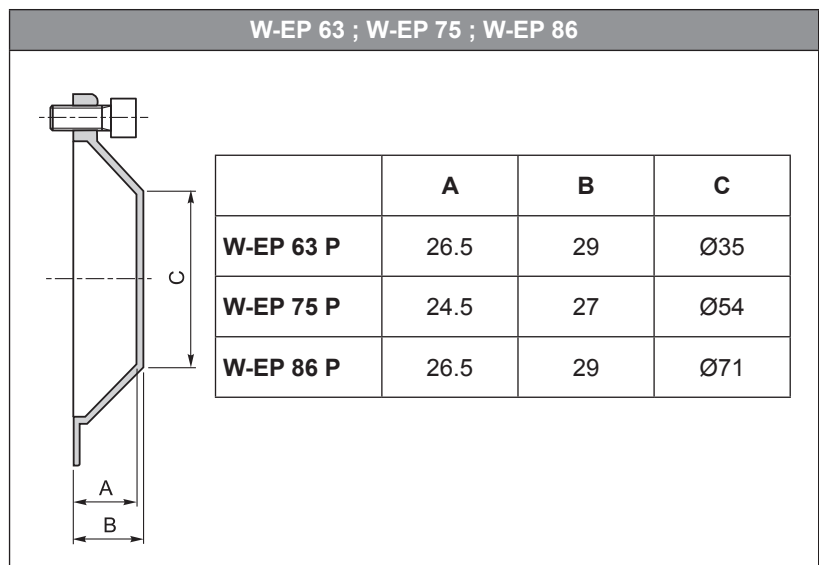
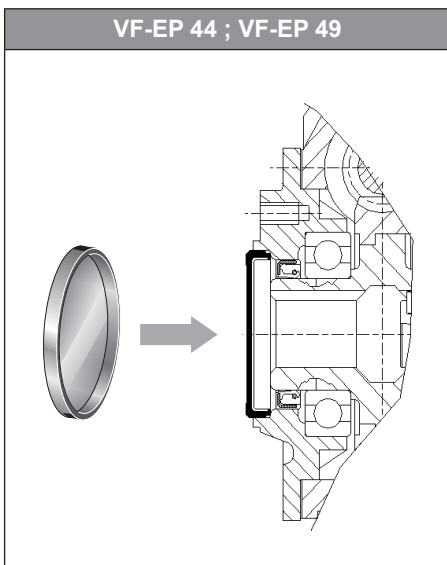

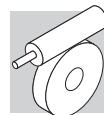

DISPOSITIF DE FIN DE COURSE RVS

37 INFORMATIONS GÉNÉRALES

Le dispositif de fin de course type RVS est conçu pour compléter et adapter les motoréducteurs à vis sans fin Bonfiglioli Riduttori à l'actionnement de:

- fenêtres et dispositifs d'ombrage pour serres
- grilles automatiques
- fenêtre à vasistas
- doseurs pour grenailles dans le secteur zootechnique
- vannes papillon

Les motoréducteurs équipés du dispositif RVS sont aussi adaptés pour toute autre application intermittente nécessitant un mouvement contrôlé et précis.

En ce qui concerne les applications susmentionnées, caractérisées par un type de service léger et intermittent, il est recommandé d'effectuer la sélection du groupe de transmission uniquement depuis les pages du paragraphe 40. Les sélections ainsi effectuées seront conformes au type de service particulier ainsi qu'aux vitesses maximales compatibles avec le fonctionnement régulier du dispositif de fin de course.

Pour obtenir la configuration complète, assembler le dispositif de fin de course sur le motoréducteur correspondant au moyen du kit de montage spécifique (disponible pour les groupes types VF 49, W63, W75 et W86), illustré à la page suivante.

Afin de permettre le montage du dispositif **RVS**, les motoréducteurs doivent être de forme de construction à bride.

37.1 Caractéristiques techniques

Le fonctionnement du dispositif de fin de course est basé sur le mouvement différentiel de deux couples de roues, dotées de came, et de l'actionnement correspondant de microrupteurs de précision, qui, à travers des relais (à la charge de l'installateur) commandent l'arrêt et l'inversion du mouvement. Les positions extrêmes du mouvement, généralement l'ouverture et la fermeture du bâti, sont facilement définissables avec le motoréducteur déjà installé et sans utilisation d'outils spécifiques autre qu'une clé à six pans ordinaire.

Une fois le réglage désiré obtenu et fixé, ce dernier est constant dans le temps, ce qui permet une répétitivité élevée des actionnements.

Dans son exécution de base, le groupe de fin de course **RVS** est fourni avec une paire de câbles, d'une longueur d'environ un mètre, précâblés à l'intérieur.

Le groupe est aussi disponible dans les variantes suivantes :

RVS ME: dotée de boîte à bornes extérieure à six bornes auxquelles seront reliés les câbles de raccordement avec les relais.

RVS DM: équipée d'une double série de microrupteurs reliés en série, pour une sécurité d'intervention absolue et conforme aux normes prévoyant la redondance de ce dispositif.

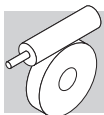



RVS ME DM: dispositif équipé de boîte à bornes extérieure et d'une double série de microrupteurs, comme décrit plus haut.

Quelles que soient les variantes, les caractéristiques du dispositif de fin de course sont les suivantes:



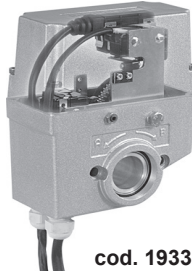
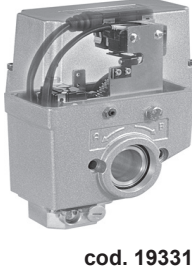

- extrêmement silencieux
- encombrement limité
- facile à installer et à régler
- doté de protection IP55
- réglable à l'intérieur d'une plage de 43 tours de l'arbre de sortie

38 REFERENCES POUR LA COMMANDE

Repérer le dispositif, ou sa variante, nécessaire pour l'application et se référer au tableau ci-dessous pour trouver la référence correspondante pour effectuer la commande :

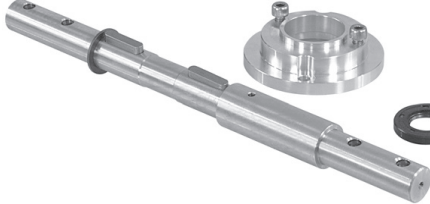
RVS	RVS ME	RVS DM	RVS ME DM
 cod. 193312025	 cod. 193312026	 cod. 193312027	 cod. 193312028

Sélectionner aussi la référence relative au kit de configuration pour le réducteur sur lequel le dispositif de fin de course sera installé:

 cod. 192860001	 cod. 192860002	 cod. 192860003	 cod. 192860004
---	---	--	--

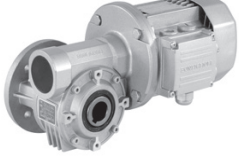
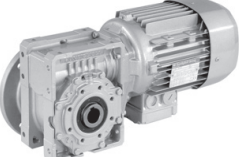
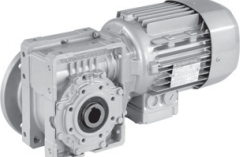
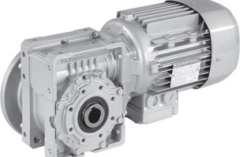
 VF 49 F - VFR 49 F	 W 63 UFC - WR 63 UFC	 W 75 UFC - WR 75 UFC	 W 86 UFC - WR 86 UFC
---	---	--	---

39 DESIGNATION

Désignation **VF** et **W** pour accouplement dispositif fin de course.

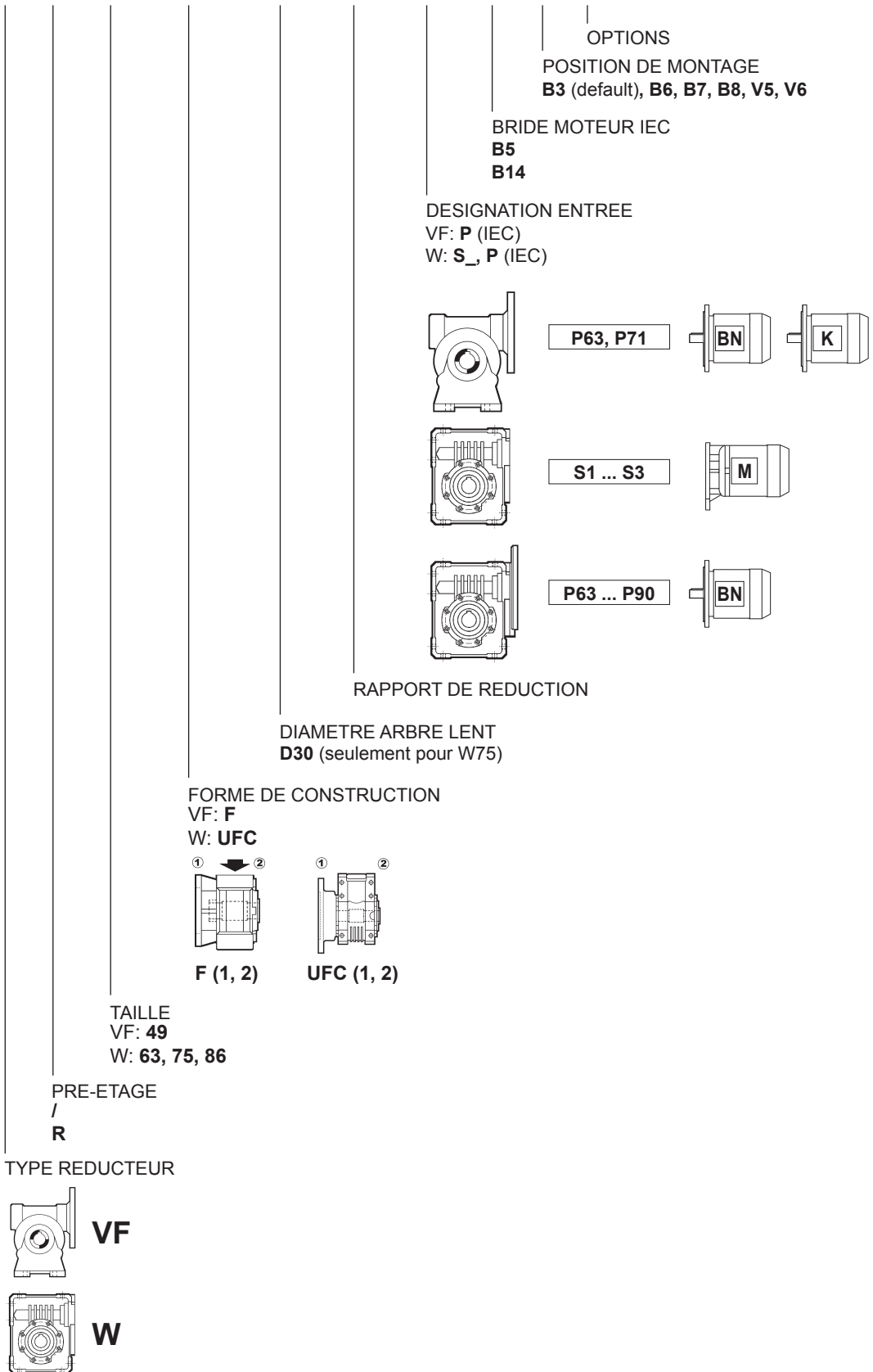

W R 75 UFC1 D30 240 P71 B5 B3

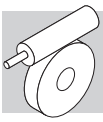



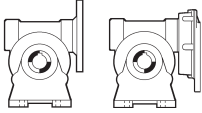

40 TABLEAUX SELECTION MOTOREDUCTEUR

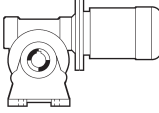

0.12 kW

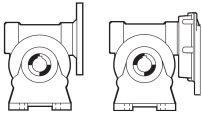
n_2 min ⁻¹	M_2 Nm	i		IEC 	
4.7	98	300	VFR 49_300	P63 BN63A4	
5.8	89	240	VFR 49_240	P63 BN63A4	
6.7	83	210	VFR 49_210	P63 BN63A4	
7.8	76	180	VFR 49_180	P63 BN63A4	
10.4	64	135	VFR 49_135	P63 BN63A4	
14.0	41	100	VF 49_100	P63 BN63A4	VF 49_100 P63 K63A4
17.5	37	80	VF 49_80	P63 BN63A4	VF 49_80 P63 K63A4
20.0	34	70	VF 49_70	P63 BN63A4	VF 49_70 P63 K63A4
23.3	31	60	VF 49_60	P63 BN63A4	VF 49_60 P63 K63A4

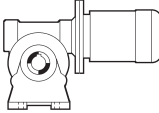
0.18 kW

n_2 min ⁻¹	M_2 Nm	i		IEC 	
7.8	112	180	VFR 49_180	P63 BN63B4	
10.4	95	135	VFR 49_135	P63 BN63B4	
14.0	61	100	VF 49_100	P63 BN63B4	
17.5	54	80	VF 49_80	P63 BN63B4	VF 49_80 P63 K63B4
20.0	49	70	VF 49_70	P63 BN63B4	VF 49_70 P63 K63B4
23.3	45	60	VF 49_60	P63 BN63B4	VF 49_60 P63 K63B4

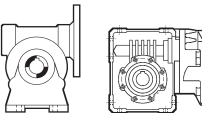
0.25 kW

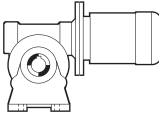
n_2 min ⁻¹	M_2 Nm	i		IEC 	
4.7	214	300	WR 63_300	P71 BN71A4	
5.8	192	240	WR 63_240	P71 BN71A4	
7.3	170	192	WR 63_192	P71 BN71A4	
10.4	136	135	WR 63_135	P71 BN71A4	
12.3	121	114	WR 63_114	P71 BN71A4	
14.0	82	100	VF 49_100	P71 BN71A4	
17.5	72	80	VF 49_80	P71 BN71A4	
20.0	66	70	VF 49_70	P71 BN71A4	
23.3	61	60	VF 49_60	P71 BN71A4	VF 49_60 P71 K71A4

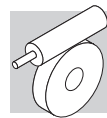

0.37 kW

n_2 min ⁻¹	M_2 Nm	i		IEC		
4.7	382	300	WR 86_300	P71	BN71B4	
5.8	306	240	WR 75_240	P71	BN71B4	
7.3	290	192	WR 86_192	P71	BN71B4	
7.8	257	180	WR 75_180	P71	BN71B4	
9.3	226	150	WR 75_150	P71	BN71B4	
10.4	204	135	WR 63_135	P71	BN71B4	W 63_100 S1 M1SD4
12.3	181	114	WR 63_114	P71	BN71B4	
14.0	133	100	W 63_100	P71	BN71B4	
17.5	108	80	VF 49_80	P71	BN71B4	
20.0	98.3	70	VF 49_70	P71	BN71B4	
23.3	90.5	60	VF 49_60	P71	BN71B4	



0.55 kW

n_2 min ⁻¹	M_2 Nm	i		IEC		
4.7	559	300	WR 86_300	P80	BN80A4	
5.8	483	240	WR 86_240	P80	BN80A4	
7.3	423	192	WR 86_192	P80	BN80A4	
7.8	376	180	WR 75_180	P80	BN80A4	
8.3	383	168	WR 86_168	P80	BN80A4	
9.3	331	150	WR 75_150	P80	BN80A4	W 63_100 S1 M1LA4 W 63_80 S1 M1LA4 W 63_64 S1 M1LA4 W 75_60 S1 M1LA4
10.1	330	138	WR 86_138	P80	BN80A4	
11.7	287	120	WR 75_120	P80	BN80A4	
14.0	194	100	W 63_100	P80	BN80A4	
17.5	170	80	W 63_80	P80	BN80A4	
21.9	148	64	W 63_64	P80	BN80A4	
23.3	148	60	W 75_60	P80	BN80A4	

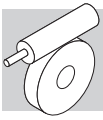

0.75 kW

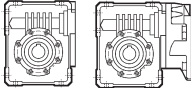
n_2 min ⁻¹	M_2 Nm	i		IEC		
7.3	568	192	WR 86_192	P80	BN80B4	
8.3	514	168	WR 86_168	P80	BN80B4	
9.3	444	150	WR 75_150	P80	BN80B4	
10.1	443	138	WR 86_138	P80	BN80B4	
11.7	386	120	WR 75_120	P80	BN80B4	
14.0	281	100	W 75_100	P80	BN80B4	W 75_100 S2 M2SA4
17.5	241	80	W 75_80	P80	BN80B4	W 75_80 S2 M2SA4
21.9	199	64	W 63_64	P80	BN80B4	W 63_64 S2 M2SA4
23.3	199	60	W 75_60	P80	BN80B4	W 75_60 S2 M2SA4

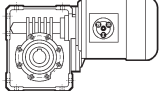
**1.1 kW**

n_2 min ⁻¹	M_2 Nm	i				
10.1	652	138	WR 86_138	P90	BN90S4	
11.7	594	120	WR 86_120	P90	BN90S4	
14.0	443	100	W 86_100	P90	BN90S4	W 86_100 S2 M2SB4
17.5	384	80	W 86_80	P90	BN90S4	W 86_80 S2 M2SB4
21.9	326	64	W 86_64	P90	BN90S4	W 86_60 S2 M2SB4

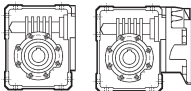
1.5 kW

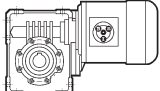
n_2 min ⁻¹	M_2 Nm	i				
11.7	816	120	WR 86_120	P90	BN90LA4	
17.5	527	80	W 86_80	P90	BN90LA4	W 86_80 S3 M3SA4
21.9	448	64	W 86_64	P90	BN90LA4	W 86_60 S3 M3SA4

41 DIMENSIONS

VF 49_F - VFR 49_F

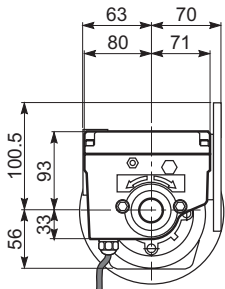

VF 49_F

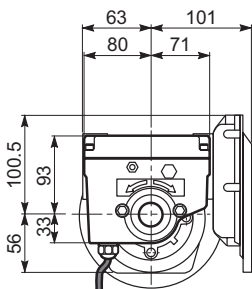
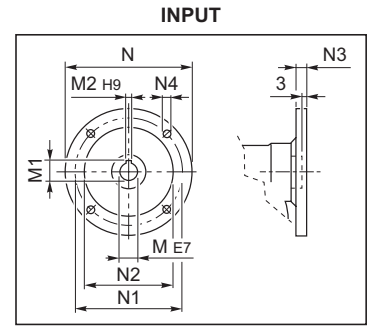
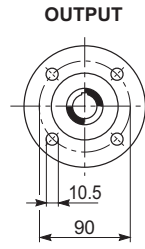
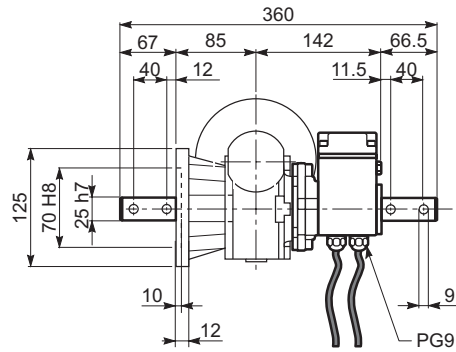

VFR 49_F

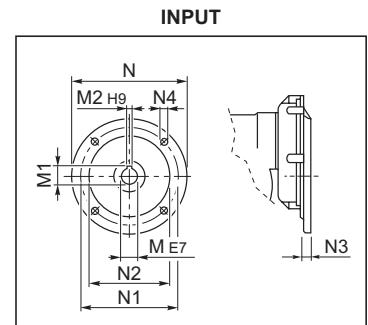
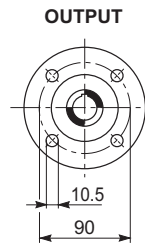
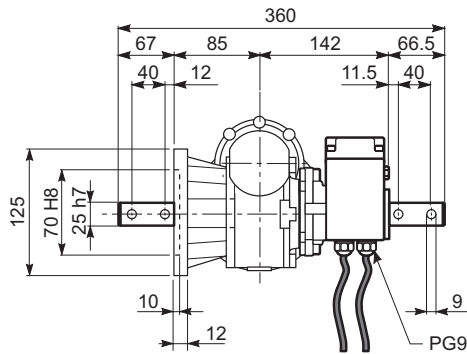

	M	M1	M2	N	N1	N2	N3	N4
VF 49_P 63	11	12.8	4	140	115	95	10.5	9.5
VF 49_P 71	14	16.3	5	160	130	110	10.5	9.5
VFR 49_P 63	11	12.8	4	140	115	95	11	M8x19

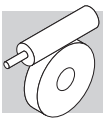

W 63 UFC_M - W 63 UFC - WR 63 UFC

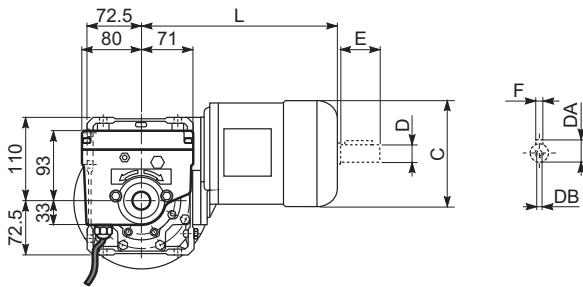

W 63 UFC_M

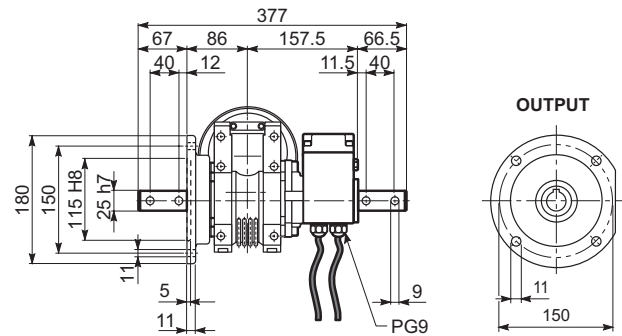

	C	D	DA	DB	E	F	L
W 63_S1 M1L	138	14	16	M5	30	5	289
W 63_S2 M2S	156	19	21.5	M6	40	6	317

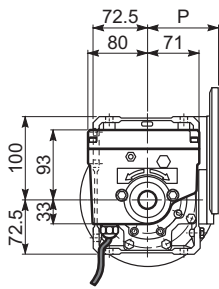

W 63 UFC

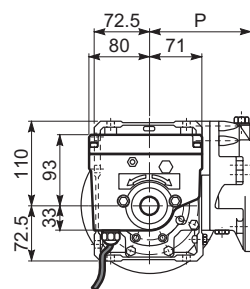
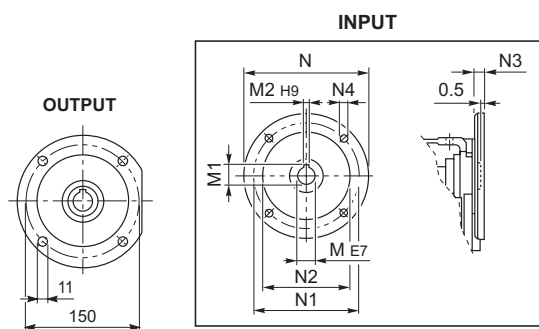
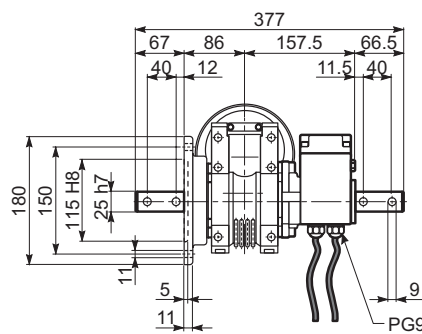

WR 63 UFC

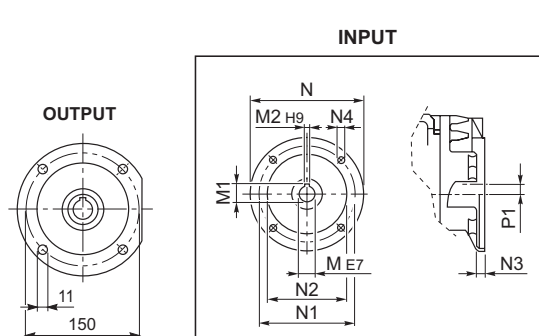
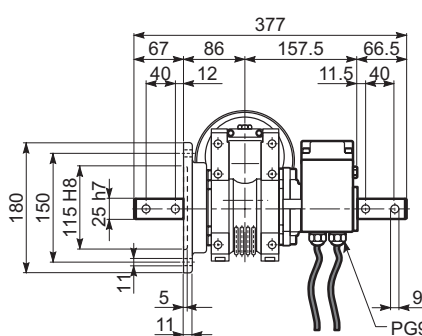

	M	M1	M2	N	N1	N2	N3	N4	P	P1
W 63_P 71	14	16.3	5	160	130	110	11	9	95	-
W 63_P 80	19	21.8	6	200	165	130	12	11.5	102	-
W 63_P 90	24	27.3	8	200	165	130	12	11.5	102	-
WR 63_P 63	11	12.8	4	140	115	95	10	M8x10	133.5	11.42
WR 63_P 71	14	16.3	5	160	130	110	10	M8x10	133.5	11.42

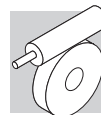

W 75 UFC_M - W 75 UFC - WR 75 UFC

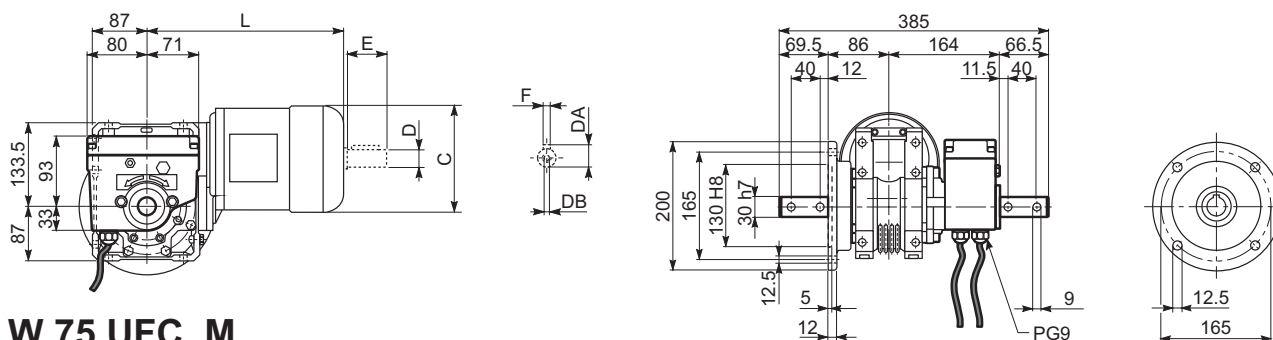

W 75 UFC_M

	C	D	DA	DB	E	F	L
W 75_S1 M1L	138	14	16	M5	30	5	308
W 75_S2 M2S	156	19	21.5	M6	40	6	333
W 75_S3 M3S	193	28	31	M10	60	8	376
W 75_S3 M3L	193	28	31	M10	60	8	408

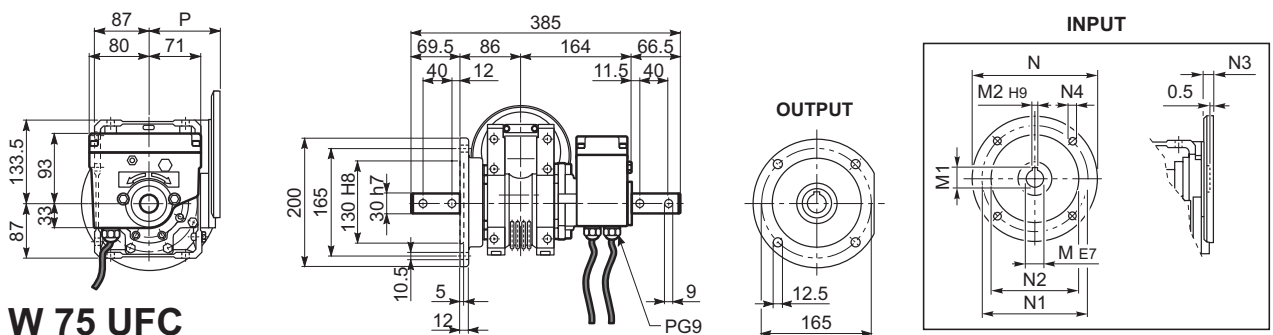

W 75 UFC

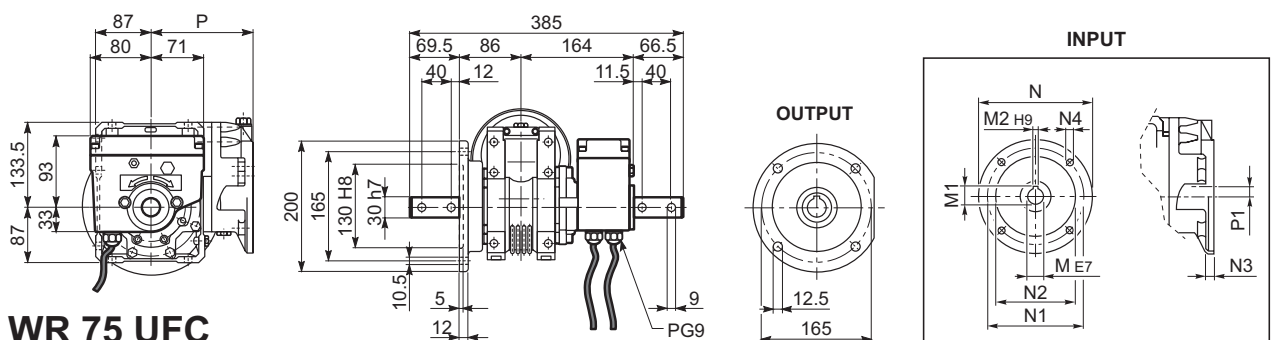

WR 75 UFC

	M	M1	M2	N	N1	N2	N3	N4	P	P1
W 75_P 71	14	16.3	5	160	130	110	11	9	112	-
W 75_P 80	19	21.8	6	200	165	130	12	11.5	112	-
W 75_P 90	24	27.3	8	200	165	130	12	11.5	112	-
WR 75_P 63	11	12.8	4	140	115	95	10	M8x10	152	23.53
WR 75_P 71	14	16.3	5	160	130	110	10	M8x10	152	23.53
WR 75_P 80	19	21.8	6	200	165	130	12	M10x13	163.5	11
WR 75_P 90	24	27.3	8	200	165	130	12	M10x13	163.5	11

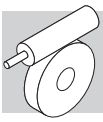

W 86 UFC_M - W 86 UFC - WR 86 UFC

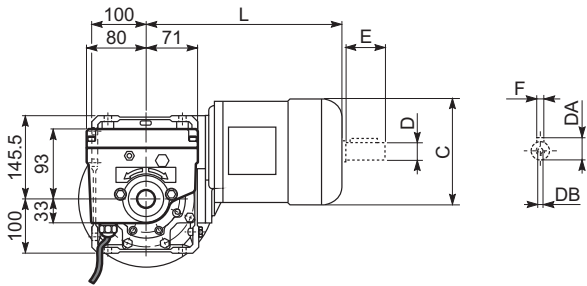

W 86 UFC_M

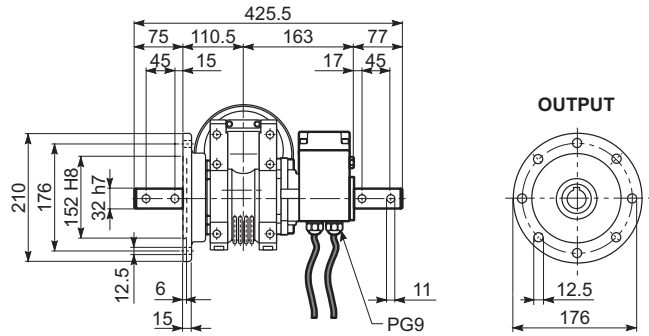

	C	D	DA	DB	E	F	L
W 86_S1 M1L	138	14	16	M5	30	5	324
W 86_S2 M2S	156	19	21.5	M6	40	6	349
W 86_S3 M3S	193	28	31	M10	60	8	392
W 86_S3 M3L	193	28	31	M10	60	8	424

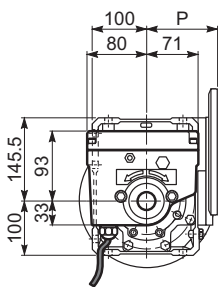

W 86 UFC

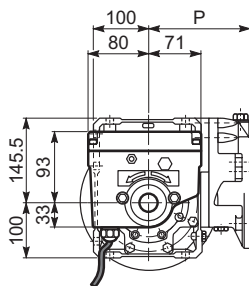
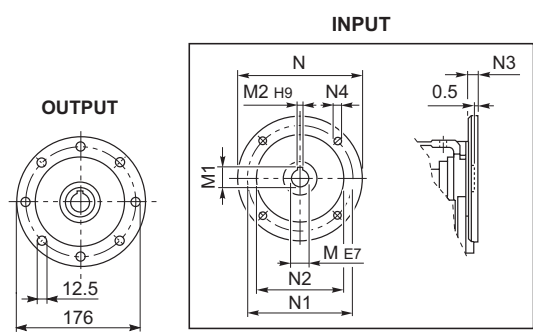
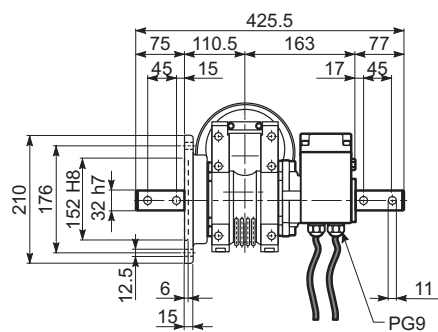

WR 86 UFC

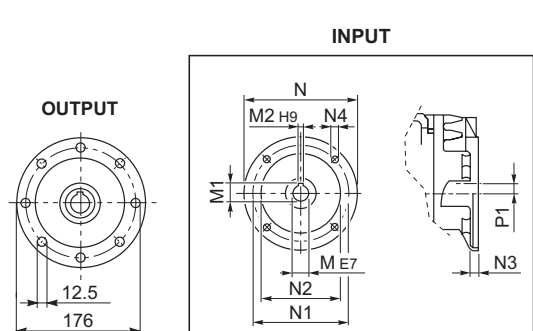
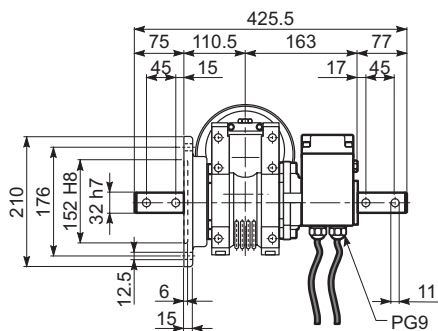

	M	M1	M2	N	N1	N2	N3	N4	P	P1
W 86_P 71	14	16.3	5	160	130	110	11	9	128	-
W 86_P 80	19	21.8	6	200	165	130	12	11.5	128	-
W 86_P 90	24	27.3	8	200	165	130	12	11.5	128	-
WR 86_P 63	11	12.8	4	140	115	95	10	M8x10	168	35.4
WR 86_P 71	14	16.3	5	160	130	110	10	M8x10	168	35.4
WR 86_P 80	19	21.8	6	200	165	130	12	M10x13	179.5	22.9
WR 86_P 90	24	27.3	8	200	165	130	12	M10x13	179.5	22.9

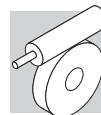

42 OPTIONS

Variantes fin de course

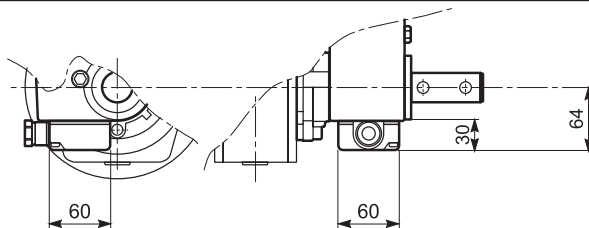
ME

Version avec boîte à bornes

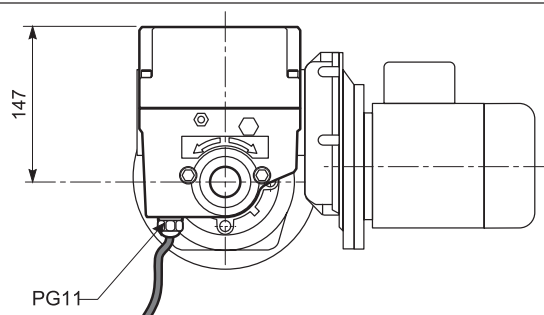
DM

Version équipée de quatre microrupteurs

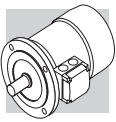

MOTEURS ELECTRIQUES

M1 SYMBOLES ET UNITES DE MESURE

Symboles	Unités de mesure	Descrizione	Symboles	Unités de mesure	Descrizione
$\cos\phi$	–	Facteur de puissance	n	[min ⁻¹]	Vitesse nominale
η	–	Rendement	P_B	[W]	Puissance absorbée par le frein à 20°C
f_m	–	Facteur de correction de la puissance	P_n	[kW]	Puissance nominale
I	–	Rapport d'intermittence	P_r	[kW]	Puissance nécessaire
I_N	[A]	Courant nominal	t_1	[ms]	Temps de déblocage du frein avec alimentation à demi-onde
I_s	[A]	Courant de démarrage	t_{1s}	[ms]	Temps de déblocage du frein avec alimentation à contrôle électronique
J_C	[Kgm ²]	Moment d'inertie de la charge	t_2	[ms]	Retard de freinage avec coupure coté c.a.
J_M	[Kgm ²]	Moment d'inertie du moteur	t_{2c}	[ms]	Retard de freinage avec coupure coté c.a. et c.c.
K_C	–	Facteur de couple	t_a	[°C]	Température ambiante
K_d	–	Facteur de charge	t_f	[min]	Temps de fonctionnement à charge constante
K_J	–	Facteur d'inertie	t_r	[min]	Temps de repos
M_A	[Nm]	Couple d'accélération moyen	W	[J]	Energie de freinage accumulée entre deux réglages de l'entrefer
M_B	[Nm]	Couple du frein	W_{max}	[J]	Energie maxi par freinage
M_N	[Nm]	Couple nominal	Z	[1/h]	Nombre de démarrages admissibles en charge
M_L	[Nm]	Couple résistant moyen	Z_0	[1/h]	Nombre de démarrages admissibles à vide (I = 50%)
M_S	[Nm]	Couple de démarrage			

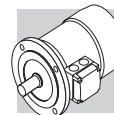

M2 CARACTERISTIQUES GENERALES

M2.1 Programme de production

Les moteurs électriques asynchrones triphasés du programme de production de BONFIGLIOLI RIDUTTORI sont prévus dans les formes de construction de base IMB5, IMB14 et leur dérivés avec les polarités suivantes : 2, 4, 6, 2/4, 2/6, 2/8, 2/12.

Dans le présent catalogue sont également mises en évidence les caractéristiques techniques des moteurs en version compacte, type M.

M2.2 Réglementations

Les moteurs décrits dans ce catalogue sont construits en accord avec les Normes et standardisations applicables mises en évidence dans le tableau ci-dessous.

(F 1)

Titre	CEI	IEC
Prescriptions générales pour machines électriques tournantes	CEI EN 60034-1	IEC 60034-1
Définitions des bornes et sens de rotation pour machines électriques tournantes	CEI 2-8	IEC 60034-8
Méthodes de refroidissement des machines électriques	CEI EN 60034-6	IEC 60034-6
Dimensions, puissances nominales pour machines électriques tournantes	EN 50347	IEC 60072
Classification des degrés de protection des machines électriques tournantes	CEI EN 60034-5	IEC 60034-5
Limites de bruit	CEI EN 60034-9	IEC 60034-9
Sigles de dénomination des formes de construction et des types d'installation	CEI EN 60034-7	IEC 60034-7
Tension nominale pour les systèmes de distribution publique de l'énergie électrique en basse tension	CEI 8-6	IEC 60038
Degré de vibration des machines électriques	CEI EN 60034-14	IEC 60034-14

En outre, les moteurs correspondent aux Normes étrangères adaptées aux IEC 60034-1 indiquées dans le tableau ci-dessous.

(F 2)

DIN VDE 0530	Allemagne
BS5000 / BS4999	Grande Bretagne
AS 1359	Australie
NBNC 51 - 101	Belgique
NEK - IEC 34	Norvège
NF C 51	France
OEVE M 10	Autriche
SEV 3009	Suisse
NEN 3173	Pays Bas
SS 426 01 01	Suède

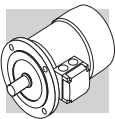

M2.3 Moteurs pour Etats-unis et Canada

CUS

Les moteurs BN et M sont disponibles en exécution NEMA Design C (pour les caractéristiques électriques), certifiés conformes aux normes CSA (Canadian Standard) C22.2 N°100 et UL (Underwriters Laboratory) UL 1004-1 avec une plaque signalétique indiquant chacun des symboles ci-dessous, dans ce cas, spécifier l'option CUS.



Les tensions des réseaux de distribution américains ainsi que les tensions nominales à spécifier pour le moteur sont indiquées dans le tableau suivant :

(F 3)

Fréquence	Tension de réseau	V _{mot}
60 Hz	208 V	200 V
	240 V	230 V
	480 V	460 V
	600 V	575 V

Les moteurs avec connexion YY/Y (ex. 230/460-60; 220/440-60) présentent, en standard, une plaque à bornes avec 9 bornes. Pour les mêmes exécutions, et aussi pour l'alimentation 575V-60Hz, la puissance de plaque correspond à celle normalisée à 50Hz.

Pour les moteurs frein avec frein en c.c. type BN/m_FD et BN/M_AFD, l'alimentation du redresseur provient de la boîte à bornes moteur avec une tension 230V c.a. monophasée. Pour les moteurs frein l'**alimentation du frein** est la suivante :

(F 4)

BN_FD ; BN_AFD M_FD ; M_AFD	BN_FA ; BN_BA M_FA	Spécifier
Depuis boîte à bornes moteur 1~230V c.a.	Alimentation séparée 230V Δ - 60Hz	230SA
	Alimentation séparée 460V Y - 60Hz	460SA

L'option CUS n'est pas applicable aux moteurs dotés d'une servo-ventilation ou aux moteurs équipés du frein AFD.

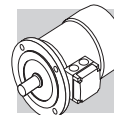

M2.4 China Compulsory Certification

CCC

Les moteurs électriques destinés à être commercialisés dans la République Populaire de Chine entrent dans le cadre du système de certification CCC (China Compulsory Certification). Les moteurs BN ayant un couple nominal pouvant atteindre 7 Nm sont disponibles avec une certification CCC et une plaque spéciale sur laquelle figure la marque illustrée ci-dessous :



L'option CCC n'est pas applicable aux moteurs équipés du frein AFD.

M2.5 Directives 2006/95/CE (LVD) et 2004/108/CE (EMC)

Les moteurs de la série BN et M sont conformes aux conditions requises par les Directives 2006/95/CE (Directive Basse Tension) et 2004/108/CE (Directive Compatibilité Electromagnétique), et le marquage CE est indiqué sur la plaque signalétique.

En ce qui concerne la Directive EMC, la fabrication répond aux Normes CEI EN 60034-1, EN 61000-6-2, EN 61000-6-4.

Les moteurs avec frein FD et AFD, s'ils sont équipés du filtre capacitif approprié en entrée du redresseur (option **CF**), entrent dans les limites d'émission prévues par la Norme EN 61000-6-3:2007 "Compatibilité électromagnétique - Norme Générique sur l'émission - Partie 6-3 : Milieux résidentiels, commerciaux et de l'industrie légère".

Les moteurs répondent aussi aux prescriptions de la Norme CEI EN 60204-1 "Equipement électrique des machines".

Le fabricant ou le monteur de la machine qui comprend les moteurs comme composant est responsable et doit se charger de garantir la sécurité et la conformité aux directives du produit final.

M2.6 Tolérances

Selon les Normes, les tolérances indiquées dans le tableau ci-dessous sont admises sur les tailles garanties.

(F 5)

-0.15 (1 - η) P \leq 50kW	Rendement
-(1 - $\cos\phi$)/6 min 0.02 max 0.07	Facteur de puissance
$\pm 20\%$ *	Glissement
+20%	Courant à rotor bloqué
-15% +25%	Couple à rotor bloqué
-10%	Couple max

* $\pm 30\%$ pour moteurs avec Pn < 1 kW

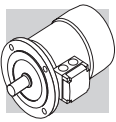

M3 CARACTERISTIQUES MECANQUES

M3.1 Formes de construction

Les moteurs série BN sont prévus dans les formes de construction indiquées sur le tableau (F6) selon les normes CEI EN 60034-14.

Les formes de construction sont les suivantes :

IM B5 (base)

IM V1, IM V3 (dérivées)

IMB14 (base)

IM V18, IMV19 (dérivées)

Les moteurs en forme de construction IM B5 peuvent être installés dans les positions IM V1 et IM V3 ; les moteurs en forme de construction IM B14 peuvent être installés dans les positions IM V18 et IM V19.

Dans ces cas, la forme de construction base IM B5 ou IM B14 sera indiquée sur la plaque du moteur. Dans les formes de construction où le moteur présente une position verticale avec arbre vers le bas, nous conseillons de demander l'exécution avec capot de protection contre la pluie (à prévoir toujours dans le cas de moteurs freins). Cette exécution, prévue dans les options, doit être expressément demandée en phase de commande étant donné qu'elle n'est pas prévue dans la version de base

(F 6)

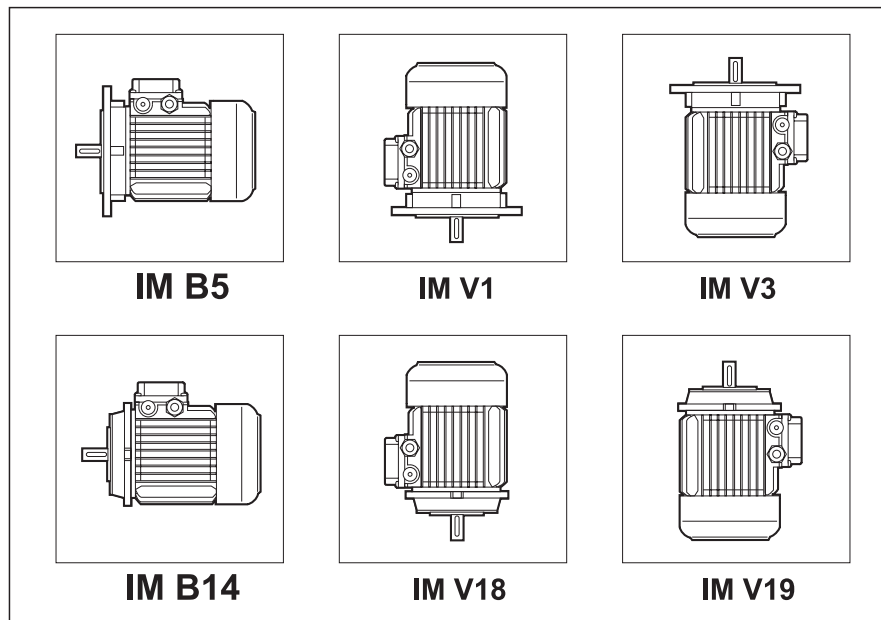

Les moteurs avec forme à bride peuvent être fournis avec des tailles d'accouplement réduites, comme indiqué dans le tableau (F7) - exécutions **B5R, B14R**.

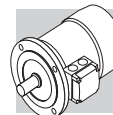

(F 7)

	BN 71	BN 80	BN 90	BN 100	BN 112	BN 132
	DxE - Ø					
B5R ⁽¹⁾	11x23 - 140	14x30 - 160	19x40 - 200	24x50 - 200	24x50 - 200	28x60 - 250
B14R ⁽²⁾	11x23 - 90	14x30 - 105	19x40 - 120	24x50 - 140	—	—

(1) bride avec orifices passants

(2) bride avec orifices filetés

M3.2 Degré de protection

IP..

Le tableau ci-dessous résume la disponibilité des différents degrés de protection.

Indépendamment du degré de protection spécifié, en cas d'installation en plein air, les moteurs doivent être protégés des rayons directs du soleil et, en cas d'installation avec l'arbre dirigé vers le bas, il est nécessaire de spécifier ultérieurement le capot de protection contre la pénétration de l'eau et des corps solides (option **RC**).

(F 8)

		IP 54	IP 55	IP 56
BN	M	⊘	standard	
BN_FD BN_AFD BN_FA	M_FD M_AFD M_FA	standard		⊘
BN_BA	-	⊘	standard	⊘

M3.3 Ventilation

Les moteurs sont refroidis à l'aide d'une ventilation extérieure (IC 411 selon CEI EN 60034-6) et sont dotés d'un ventilateur à ailettes en plastique qui fonctionne dans les deux sens de rotation.

L'installation doit assurer une distance minimum entre le capot de protection du ventilateur et la paroi afin de permettre une bonne circulation de l'air et rendre plus aisé l'entretien du moteur et si prévu, du frein.

Sur demande, il est possible de prévoir une ventilation forcée indépendante (option U1).

Cette solution permet d'augmenter le facteur d'utilisation du moteur en cas d'alimentation, via un variateur de fréquence, et pour un fonctionnement à faible vitesse.

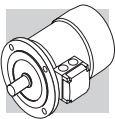

M3.4 Sens de rotation

Un fonctionnement dans les deux sens de rotation est possible. Avec raccordement des bornes U1, V1, W1 aux phases de ligne L1, L2, L3, on a la rotation dans le sens des aiguilles d'une montre vue du côté liaison alors que le sens inverse s'obtient en intervertissant deux phases entre elles.

M3.5 Niveau de bruit

Les valeurs relevées selon la méthode prévue par les normes ISO 1680 sont situées sous les niveaux maximums prévus par les normes CEI EN 60034-9.

M3.6 Vibrations et équilibrage

Tous les rotors sont équilibrés avec une demi clavette et entrent dans les limites d'intensité de vibration prévues par les Normes CEI EN 60034-14.

En cas d'exigences particulières concernant le niveau de bruit, sur demande, il est possible de réaliser une exécution anti-vibrante, de degré réduit (B).

Le tableau ci-dessous indique les valeurs de la vitesse efficace de vibration pour un équilibrage standard (A) et améliorée (B).

(F 9)

Degré de vibration	Vitesse de rotation n [min ⁻¹]	Limites de la vitesse de vibration [mm/s] BN 56 ≤ H ≤ BN 200 M05 ≤ H ≤ M5
A	600 < n < 3600	1.6
B	600 < n < 3600	0.70

Les valeurs se réfèrent à des mesures avec moteur librement suspendu et fonctionnement à vide.

M3.7 Bornier moteur

Le bornier principal prévoit six bornes pour raccordement avec cosses. Dans le boîtier se trouve une borne pour le conducteur de terre.

Les dimensions des axes de fixation sont reportées dans le tableau ci-dessous.



Pour l'alimentation du frein, voir par. M6, M7 (frein FD et AFD), M8, M9 (frein FA et BA).

Dans le cas de moteurs freins, le redresseur pour l'alimentation du frein est fixé à l'intérieur du boîtier et est doté de bornes de raccordement.

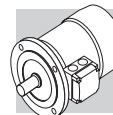
Effectuer les connexions selon les schémas indiqués à l'intérieur du bornier, ou dans les manuels d'utilisation.





(F 10)

		Nbre bornes	Filetage bornes	Section max du conducteur mm ²
BN 56...BN 71	M05, M1	6	M4	2.5
BN 80, BN 90	M2	6	M4	2.5
BN 100...BN 112	M3	6	M5	6
BN 132...BN 160MR	M4	6	M5	6
BN 160M...BN 180M	M5	6	M6	16
BN 180L...BN 200L	—	6	M8	25

M3.8 Entrée de câbles

Dans le respect de la Norme EN 50262, les orifices d'entrée de câbles dans les boîtes à bornes présentent des filetages métriques de la taille indiquée dans le tableau ci-dessous.

(F 11)

		Entrée câbles	Diam. maxi câble [mm]
BN 63	M05	2 x M20 x 1.5	13
BN 71	M1	2 x M25 x 1.5	17
BN 80 - BN 90	M2	2 x M25 x 1.5	17
BN 100	M3	2 x M32 x 1.5	21
		2 x M25 x 1.5	17
BN 112	—	2 x M32 x 1.5	17
		4 x M25 x 1.5	
BN 132...BN 160MR	M4	4 x M32 x 1.5	21
BN 160M...BN 200L	M5	2 x M40 x 1.5	29

M3.9 Roulements

Les roulements prévus sont du type radial à billes avec lubrification permanente.

Les types utilisés sont indiqués dans les tableaux ci-dessous.

La durée de vie nominale de fatigue L_{10h} des roulements en l'absence de charges extérieures appliquées est supérieure à 40.000 heures calculée selon ISO 281.

DE = sortie arbre

NDE = côté ventilateur

(F 12)

	DE		NDE	
	M, M_FD, M_AFD, M_FA	M	M_FD, M_AFD, M_FA	
M05	6004 2Z C3	6201 2Z C3	6201 2RS C3	
M1	6004 2Z C3	6202 2Z C3	6202 2RS C3	
M2	6007 2Z C3	6204 2Z C3	6204 2RS C3	
M3	6207 2Z C3	6206 2Z C3	6206 2RS C3	
M4	6309 2Z C3	6308 2Z C3	6308 2RS C3	
M5	6309 2Z C3	6309 2Z C3	6309 2RS C3	

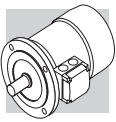

(F 13)

	DE	NDE	
	BN, BN_FD, BN_AFD, BN_FA, BN_BA	BN, BN_BA	BN_FD, BN_AFD, BN_FA
BN 56		6201 2Z C3	–
BN 63	6201 2Z C3	6201 2Z C3	6201 2RS C3
BN 71	6202 2Z C3	6202 2Z C3	6202 2RS C3
BN 80	6204 2Z C3	6204 2Z C3	6204 2RS C3
BN 90	6205 2Z C3	6205 2Z C3	6305 2RS C3
BN 100	6206 2Z C3	6206 2Z C3	6206 2RS C3
BN 112	6306 2Z C3	6306 2Z C3	6306 2RS C3
BN 132	6308 2Z C3	6308 2Z C3	6308 2RS C3
BN 160MR	6309 2Z C3	6308 2Z C3	6308 2RS C3
BN 160M/L	6309 2Z C3	6309 2Z C3	6309 2RS C3
BN 180M	6310 2Z C3	6309 2Z C3	6309 2RS C3
BN 180L	6310 2Z C3	6310 2Z C3	6310 2RS C3
BN 200L	6312 2Z C3	6310 2Z C3	6310 2RS C3

M4 CARACTERISTIQUES ELECTRIQUES

M4.1 Tension

Les moteurs à polarité unique sont prévus dans l'exécution normale pour tension 230V Δ / 400V Y, 50 Hz avec tolérance de tension $\pm 10\%$ (sauf les types M3LC4 et M3LC6).

Outre la tension nominale, les plages de fonctionnement permises sont indiquées sur la plaque signalétique, à savoir :

220-240V Δ

380-415V Y/50 Hz.

Selon les normes CEI EN 60034-1 les moteurs peuvent fonctionner aux tensions indiquées ci-dessous avec une tolérance de $\pm 5\%$.

Pour un fonctionnement à la limite de tolérance, la température peut dépasser les 10K, la limite prévue de la classe d'isolation choisie.

A l'exception des moteurs frein en c.c., type BN/M_FD et BN/M_AFD sur la plaque marque sont de plus indiquées les valeurs correspondantes au fonctionnement en 60 Hz (ex.460Y, 60 Hz) et la relative plage de tension : 440 - 480VY, 60 Hz.

En ce qui concerne les moteurs frein avec frein de type FD et AFD, les tensions standard sont les suivantes :



220V - 240V Δ - 50 Hz

380V - 415V Y - 50 Hz

avec tension d'alimentation du frein 230V $\pm 10\%$.

La tableau ci-dessous indique les tensions prévues pour les moteurs.

(F 14)

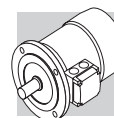

		BN M	BN_FD ; BN_AFD M_FD ; M_AFD		BN_FA ; BN_BA M_FA		Exécution
		$V_{mot} \pm 10\%$ 3 ~	$V_{mot} \pm 10\%$ 3 ~	$V_B \pm 10\%$ 1 ~	$V_{mot} \pm 10\%$ 3 ~	$V_B \pm 10\%$ 3 ~	
BN 56 - BN 132	M05...M4	230/400 - 50 Hz 460 - 60 Hz	230/400V Δ /Y- 50 Hz	230V	230/400V Δ /Y- 50 Hz 460V Y - 60Hz	230/400V Δ /Y- 50 Hz 460V Y - 60Hz	Standard
BN 100 - BN 132	M3 - M4	400/690 - 50 Hz 460 - 60Hz	400/690V Δ /Y- 50 Hz	400V	400/690V Δ /Y- 50 Hz 460V Y - 60Hz	400/690V Δ /Y- 50 Hz 460V Y - 60Hz	Sur demande, sans majoration de prix



Tous les moteurs à deux vitesses, les types 400V/50Hz, sont prévus pour une tension nominale standard de 400V ; tolérances applicables selon CEI EN 60034-1.

Dans le tableau ci-dessous sont indiqués les différents types de connexion prévus pour les moteurs.

(F 15)





		Pôles	Connexion du bobinage
BN 56...BN 200	M05...M5	2, 4, 6	Δ / Y
		2/4	Δ / YY (Dahlander)
		2/6, 2/8, 2/12	Y / Y (Deux bobinages)

M4.2 Fréquence

Les moteurs à une vitesse en exécution standard reportent sur la plaque marque en plus des tensions du fonctionnement à 50 Hz, la plage de tension 440 - 480V 60 Hz (moteurs freins avec frein FD et AFD exclus) avec puissance augmentée de 20% env.

La puissance sur la plaque marque des moteurs à 60 Hz correspond à celle indiquée au tableau suivant :

(F 16)

		2P	4P	6P			2P	4P	6P
		P_n [kW]					P_n [kW]		
BN 56A	–	–	0.06	–	BN 112M	M3LB	4.7	4.7	2.5
BN 56B	M0B	–	0.10	–		M3LC	–	4.7	2.5
BN 63A	M05A	0.21	0.14	0.10	BN 132S	M4SA	–	6.5	3.5
BN 63B	M05B	0.30	0.21	0.14	BN 132SA	M4SA	6.3	–	–
BN 71A	M05C	0.45	0.30	0.21	BN 132SB	M4SB	8.7	–	–
BN 71B	M1SD	0.65	0.45	0.30	BN 132M	M4LA	11	–	–
BN 80A	M1LA	0.90	0.65	0.45	BN 132MA	M4LA	–	8.7	4.6
BN 80B	M2SA	1.30	0.90	0.65	BN 132MB	M4LB	–	11	6.5
BN 90S	M2SB	–	1.30	0.90	BN 160MR	M4LC	12.5	12.5	–
BN 90SA	M2SB	1.8	–	–	BN 160MB	M5SB	17.5	–	–
BN 90L	M3SA	2.5	–	1.3	BN 160M	M5SA	–	–	8.6
BN 90LA	M3SA	–	1.8	–	BN 160L	M5S	21.5	17.5	12.6
BN 100L	M3LA	3.5	–	–	BN 180M	M5LA	24.5	21.5	–
BN 100LA	M3LA	–	2.5	1.8	BN 180L	–	–	25.3	17.5
BN 100LB	M3LB	4.7	3.5	2.2	BN 200L	–	34	34	22

Pour les moteurs à deux vitesses avec alimentation 60 Hz l'augmentation de puissance prévue par rapport aux valeurs indiquées dans les tableaux techniques, sera de 15%.

Si la puissance requise à 60 Hz correspond à la puissance normalisée à 50 Hz on devra indiquer l'option PN.

Les moteurs bobinés pour fréquence 50 Hz peuvent être utilisés sur réseau à 60 Hz selon les indications du tableau suivant.

Les freins, si présents, devront toujours être alimentés avec la tension V_b rapportée sur la plaque.

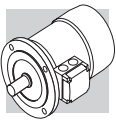

(F 17)

50 Hz	60 Hz			
V - 50 Hz	V - 60 Hz	P _n - 60 Hz	M _n , M _a /M _n - 60 Hz	n [min ⁻¹] - 60 Hz
230/400 Δ/Y	220 - 240 Δ	1	0.83	1.2
	380 - 415 Y			
400/690 Δ/Y	380 - 415 Δ			
230/400 Δ/Y	265 - 280 Δ	1.15	1	1.2
	440 - 480 Y			
400/690 Δ/Y	440 - 480 Δ			

M4.3 Puissance nominale

Les tableaux fonctionnels du catalogue présentent les caractéristiques techniques à 50 Hz dans des conditions ambiantes standard selon les normes CEI EN 60034-1 (température 40°C et altitude <1000 m).

Les moteurs peuvent être employés à des températures comprises entre 40°C et 60°C en appliquant les déclassements de puissance indiqués dans les tableaux suivants.

(F 18)

Température ambiante (°C)	40°	45°	50°	55°	60°
Puissance admissible en % de la puissance nominale	100%	95%	90%	85%	80%

Si un déclassement du moteur supérieur à 15% est requis, on devra contacter notre Service Technique.

M4.4 Classes d'isolation

CL F

De série, les moteurs fabriqués par Bonfiglioli utilisent des matériaux isolants (fil émaillé, isolants, résines d'imprégnation) en classe **F**.

CL H

Sur demande, la classe d'isolation **H** peut être spécifiée.

En général, pour les moteurs en exécution standard, l'échauffement de l'enroulement du stator se situe dans la limite de 80 K, correspondant à un échauffement de classe B.

Le choix soigné des composants du système d'isolation permet d'utiliser également les moteurs dans des climats tropicaux et en présence de vibrations normales.

Pour des applications en présence de substances chimiques agressives, ou d'humidité élevée, il est conseillé de contacter le Service Technique Bonfiglioli pour sélectionner le produit le plus adapté.

Non disponible pour les moteurs conformes aux normes CSA et UL (option CUS).

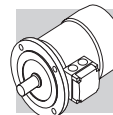

(F 19)

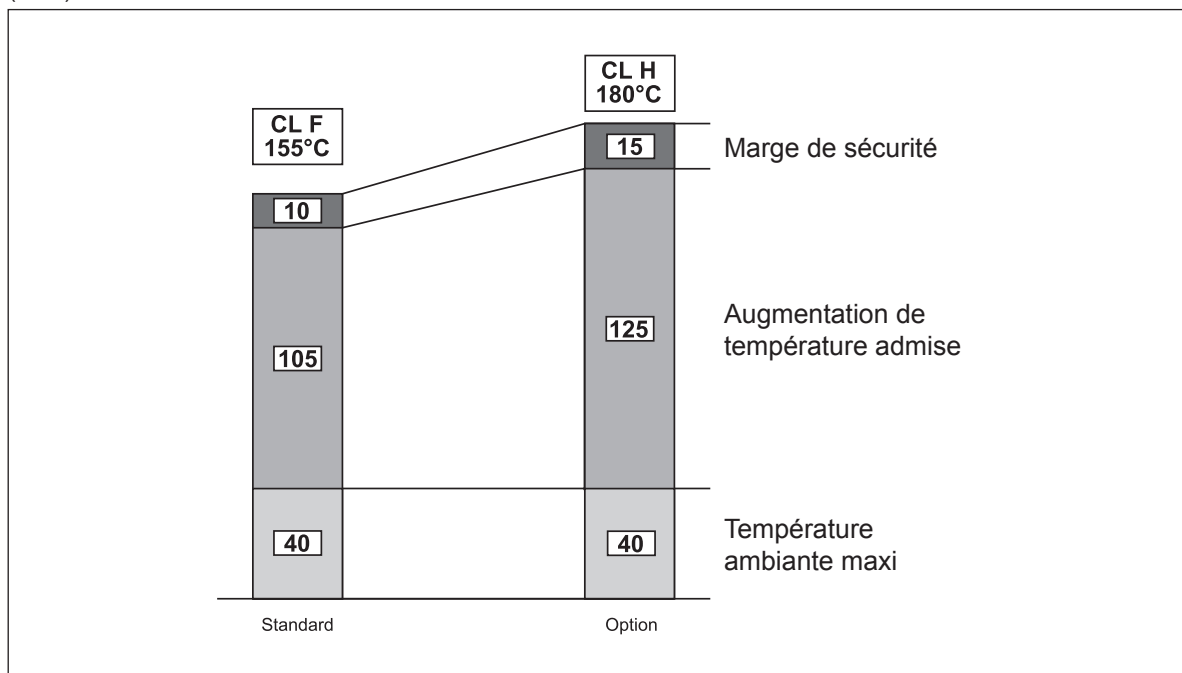

M4.5 Type de service

Sauf indication contraire, la puissance des moteurs indiquée dans le catalogue se réfère au service continu type S1. Pour les moteurs utilisés dans des conditions différentes de S1, il est nécessaire d'identifier le type de service en se référant aux Normes CEI EN 60034-1. Plus particulièrement, pour les types de service S2 et S3 il est possible d'obtenir une majoration de la puissance par rapport à celle prévue pour le service continu, en appliquant les coefficients indiqués dans le tableau suivant, valable pour les moteurs à simple polarité.

En alternative au service continu S1, en phase de configuration du produit, il est possible de sélectionner une des valeurs suivantes : S2, S3 ou S9 ; la plaque du moteur sera renseignée avec une puissance supérieure, conformément au type de service, aux données électriques dédiées et au type de service, respectivement S2-30 min, S3-70 % ou S9.

Pour plus de détails, contacter le service technique Bonfiglioli.

En ce qui concerne les majorations applicables aux moteurs à double polarité, il est préférable de contacter le Service Technique Bonfiglioli.

(F 20)

	Service						
	S2			S3 *			S4 - S9
	Durée du cycle (min)			Rapport d'intermittence (I)			
	10	20	60	25%	40%	60%	Nous contacter
f_m	1.35	1.15	1.05	1.25	1.15	1.1	

* La durée du cycle devra être inférieure ou égale à 10 minutes. Si supérieure, contacter notre Service Technique.

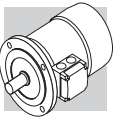

M4.5.1 Rapport d'intermittence:

$$I = \frac{t_f}{t_f + t_r} \cdot 100 \quad (23)$$

t_f = temps de fonctionnement à charge constante

t_r = temps de repos

M4.5.2 Service de durée limitée S2

Caractérisé par un fonctionnement à charge constante pour une période de temps limitée, inférieure à celle nécessaire pour atteindre l'équilibre thermique, suivie par une période de repos de durée suffisante pour rétablir, dans le moteur, la température ambiante.

M4.5.3 Service intermittent périodique S3

Caractérisé par une séquence de cycles de fonctionnement identiques, comprenant chacun une période de fonctionnement à charge constante et une période de repos.

Dans ce service, le courant de démarrage n'influence pas l'excès de température de façon significative.

M4.6 Fonctionnement avec alimentation par variateur de vitesse

Les moteurs électriques de la série BN et M peuvent être utilisés avec alimentation par variateur PWM, et tension nominale en entrée du convertisseur jusqu'à 500V. Le système adopté sur les moteurs de série prévoit l'isolation de phase avec des séparateurs, l'utilisation de fil émaillé niveau 2 et résines d'imprégnation de classe H (limite de maintien à l'impulsion de tension 1600V pic-pic et front de montée $t_s > 0.1\mu s$ aux bornes moteur). Les caractéristiques typiques couple/vitesse en service S1 pour moteur avec fréquence de base $f_b = 50$ Hz sont indiquées dans le tab. (F30).

Pour des fréquences de fonctionnement inférieures à environ 30 Hz, à cause de la diminution de la ventilation, les moteurs standards autoventilés (IC411) doivent être opportunément déclassés au niveau du couple ou, en alternative, doivent être équipés d'un servoventilateur indépendant.

Pour des fréquences supérieures à la fréquence de base, une fois la valeur maximale de tension de sortie du variateur atteinte, le moteur fonctionne dans une plage de fonctionnement à puissance constante, avec un couple à l'arbre qui diminue dans le rapport (f/f_b) . Dans la mesure où le couple maximal du moteur diminue avec $(f/f_b)^2$, la marge de surcharge admise doit être progressivement réduite.

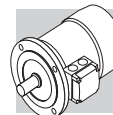

(F 21)

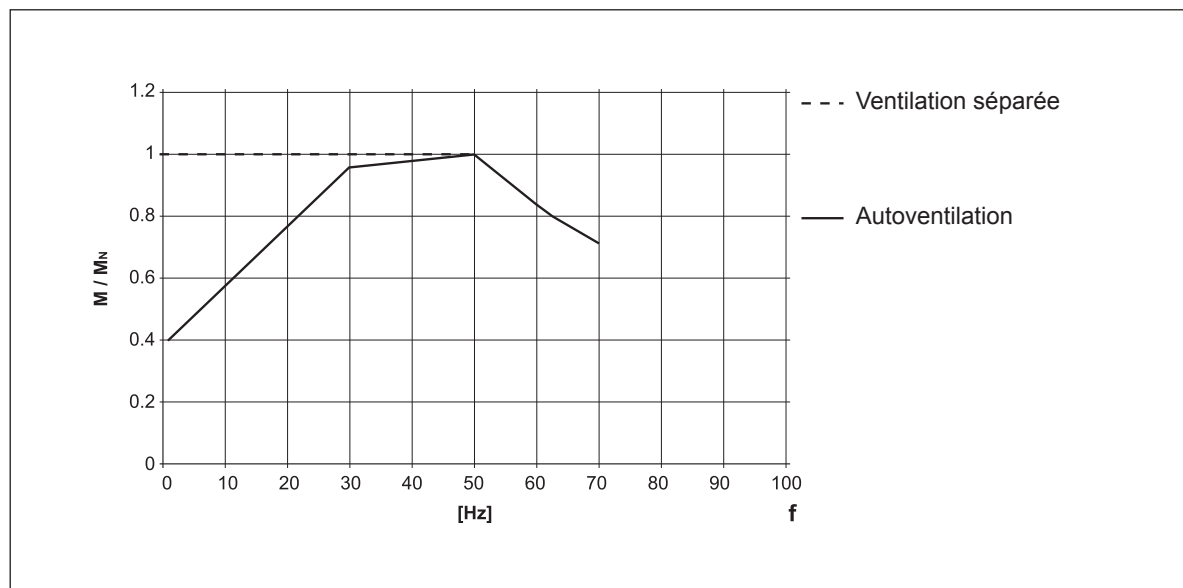

En cas de fonctionnement au-delà de la fréquence nominale, la vitesse limite mécanique des moteurs est indiquée dans le tableau (F22) :

(F 22)

		n [min ⁻¹]		
		2p	4p	6p
≤ BN 112	M05...M3	5200	4000	3000
BN 132...BN 200L	M4, M5	4500	4000	3000

A des vitesses supérieures à la vitesse nominale, les moteurs présentent plus de vibrations mécaniques et de bruit de ventilation ; pour ces applications, il est conseillé d'effectuer un équilibrage du rotor en niveau B et de monter éventuellement un servoventilateur indépendant.

Le servoventilateur et, si présent, le frein électromagnétique doivent toujours être alimentés directement par le réseau.

M4.7 Fréquence maximum de démarrage Z

Dans les tableaux des caractéristiques techniques des moteurs se trouve la fréquence maximum d'insertion à vide Z_0 avec intermittence $I = 50\%$ référée à la version frein. Cette valeur définit un nombre maximum de démarrages horaires à vide que le moteur peut supporter sans dépasser la température maximum admise par la classe d'isolation F.

Dans le cas pratique d'un moteur accouplé à une charge extérieure avec puissance absorbée P_r , masse inertielle J_c et couple résistant moyen pendant le démarrage M_L , le nombre de démarrages admissible peut se calculer de façon approximative avec la formule suivante :

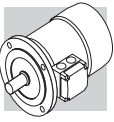

$$Z = \frac{Z_0 \cdot K_c \cdot K_d}{K_J} \quad (24)$$

où:

$$K_J = \frac{J_m + J_c}{J_m} \quad \text{facteur d'inertie}$$

$$K_c = \frac{M_a - M_L}{M_a} \quad \text{facteur de couple}$$

$$K_d = \quad \text{facteur de charge, voir le tableau suivant}$$

(F 23)

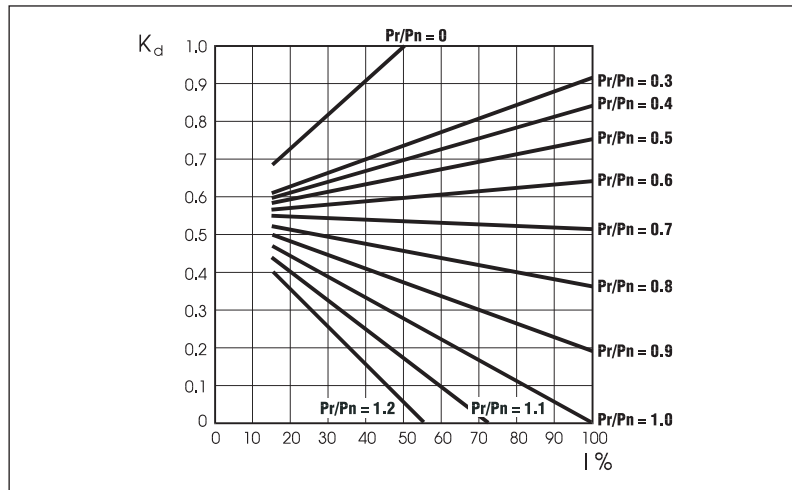

Avec le nombre de démarrages ainsi obtenu, il faudra ensuite vérifier que le travail maximum de freinage soit compatible avec la capacité thermique du frein W_{max} indiquée dans le table (F30).

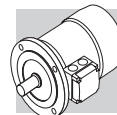

M5 MOTEURS FREIN ASYNCHRONES

M5.1 Fonctionnement

L'exécution avec frein prévoit l'utilisation de freins à pression de ressorts alimentés en c.c. (type FD, AFD) ou en c.a. (type FA, BA).

Tous les freins fonctionnent selon le principe de sécurité, c'est-à-dire qu'ils interviennent suite à la pression exercée par les ressorts, en cas de coupure d'alimentation.

(F 24)

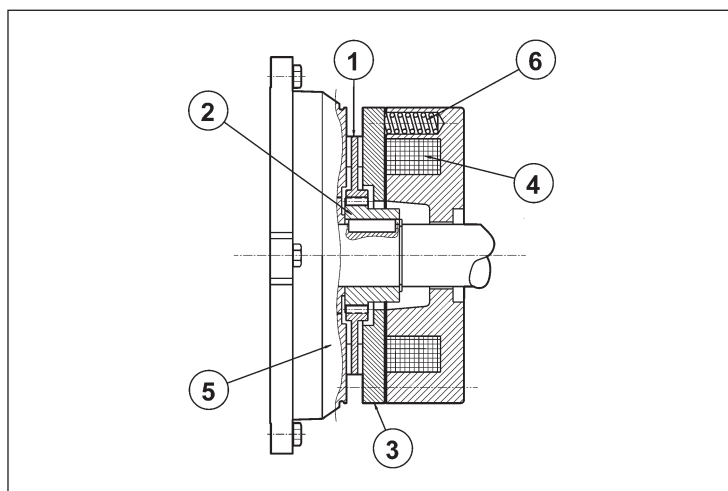

Légende:

- ① disque
- ② moyeu d'entraînement
- ③ disque de freinage
- ④ bobine de frein
- ⑤ flasque-frein
- ⑥ ressort de frein

En cas de coupure de courant, l'armature mobile, poussée par les ressorts, bloque le disque de frein entre la surface de l'armature et le bouclier moteur en empêchant la rotation de l'arbre.

Lorsque la bobine est excitée, l'attraction magnétique exercée sur l'armature mobile annule la réaction élastique des ressorts et libère le disque de frein, et par conséquent l'arbre moteur, qui est solidaire.

M5.2 Caractéristiques générales

- Couples de freinage élevés (généralement $M_b \approx 2 M_n$) et réglables.
- Disque de frein avec structure en acier à double garniture de frottement (matière à faible usure, sans amiante).
- Empreinte hexagonale sur l'arbre moteur, côté ventilateur (N.D.E.), pour la rotation manuelle (non prévue en cas de présence des options PS, RC, TC, U1, U2, EN1, EN2, EN3, EN4, EN5, EN6).
- Déblocage mécanique manuel (options **R** et **RM** pour BN/M_FD ; options **R** pour BN/M_FA).
- Déverrouillage mécanique manuel (option **R** pour BN/M_AFD).
- Traitement anticorrosion sur toute la surface du frein.
- Isolation en classe F

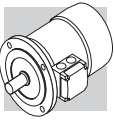

M6 MOTEURS FREIN EN C.C., TYPE BN_FD et M_FD

Tailles : BN 63 ... BN 200L / M05 ... M5

(F 25)

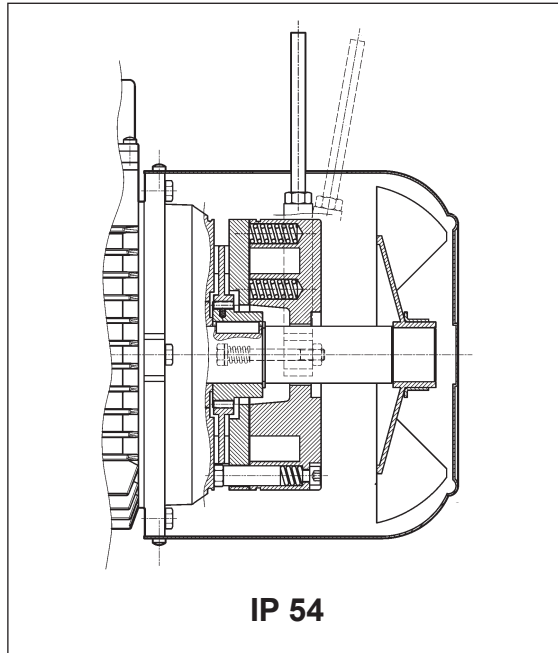

(F 26)

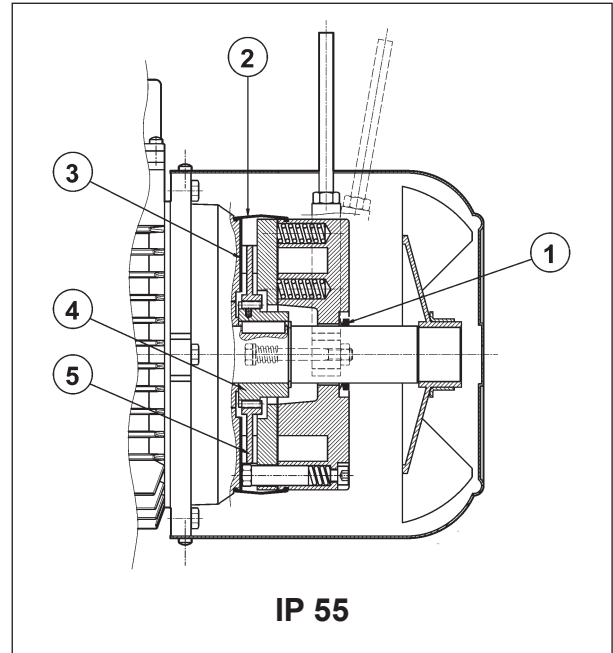

Frein électromagnétique avec bobine toroïdale en **courant continu**, fixé avec des vis au bouclier moteur ; les ressorts de précharge réalisent le positionnement axial de la bobine. Le disque frein coulisse de façon axiale sur le moyeu d'entraînement en acier calé sur l'arbre et doté d'un dispositif antivibration. Les moteurs sont fournis avec frein pré réglé en usine à la valeur de couple indiquée dans les tableaux des caractéristiques techniques ; le couple de freinage peut être réglé en modifiant le type et/ou le nombre de ressorts. Sur demande, les moteurs peuvent être équipés de levier pour le déblocage manuel avec retour automatique (**R**) ou avec maintien de la position de déblocage frein (**RM**) ; pour la position angulaire du levier de déblocage, voir description de la variante correspondante au paragraphe "SYSTEMES DE DEBLOCAGE FREIN".

Le frein FD garantit des performances dynamiques élevées et un faible niveau de bruit ; les caractéristiques d'intervention du frein en courant continu peuvent être optimisées en fonction de l'application en utilisant les différents types de dispositifs d'alimentation disponibles et/ou en réalisant un câblage approprié.

Pour des applications qui prévoient des levages et/ou des valeurs élevées de travail horaire à écouler, contacter le service technique commercial.

M6.1 Degré de protection

L'exécution standard prévoit le degré de protection IP54.

En option, le moteur frein type FD est fourni avec degré de protection **IP55**, en prévoyant les variantes de construction suivantes :

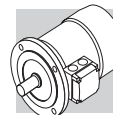

- ① abague V-ring positionnées sur l'arbre moteur N.D.E.
- ② bande de protection en caoutchouc
- ③ bague en acier inox interposée entre le bouclier moteur et le disque de frein
- ④ moyeu d'entraînement en acier inox
- ⑤ disque frein en acier inox



M6.2 Alimentation frein FD

L'alimentation de la bobine de frein en c.c. est prévue au moyen d'un redresseur approprié monté à l'intérieur de la boîte à bornes et déjà câblé à la bobine de frein.

De plus, pour les moteurs à simple polarité, le raccordement du redresseur au bornier moteur est prévu de série.

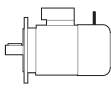

Indépendamment de la fréquence du réseau, la tension standard d'alimentation du redresseur V_B correspond à la valeur indiquée dans le tableau ci-dessous :

(F 27)

2, 4, 6 P				1 speed	
		BN_FD / M_FD		Alimentation frein depuis boîte à bornes	Alimentation séparée
		V_{mot} $\pm 10\%$ 3 ~	V_B $\pm 10\%$ 1 ~		
BN 63...BN 132	M05...M4LB	230/400 V – 50 Hz	230 V	standard	spécifier V_B SA ou V_B SD
BN 160...BN 200	M4LC...M5	400/690 V – 50 Hz	400 V	standard	spécifier V_B SA ou V_B SD

Pour les moteurs à double polarité, l'alimentation standard du frein dérive d'une ligne séparée avec tension d'entrée au redresseur V_B comme indiqué dans le tableau ci-dessous :

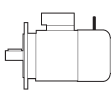

(F 28)

2/4, 2/6, 2/8, 2/12, 4/6, 4/8 P				2 speed	
		BN_FD / M_FD		Alimentation frein depuis boîte à bornes	Alimentation séparée
		V_{mot} $\pm 10\%$ 3 ~	V_B $\pm 10\%$ 1 ~		
BN 63...BN 132	M05...M4LB	400 V – 50 Hz	230 V		spécifier V_B SA ou V_B SD

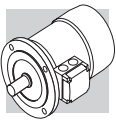
Le redresseur est du type à diodes à demi-onde ($V_{c.c} \approx 0,45 \times V_{c.a.}$) et il est disponible dans les versions **NB**, **SB**, **NBR** et **SBR**, comme indiqué de façon détaillée dans le tableau suivant :

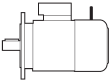
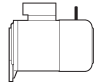

(F 29)

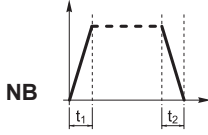
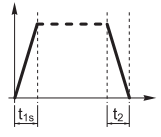
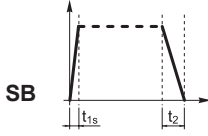
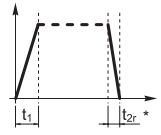
  frein				
			standard	Sur demande
BN 63	M05	FD 02		
BN 71	M1	FD 03		
		FD 53		
BN 80	M2	FD 04		
BN 90S	—	FD 14		
BN 90L	—	FD 05		
BN 100	M3	FD 15		
—		FD 55		
BN 112	—	FD 06S		
BN 132...160MR	M4	FD 56		
BN 160L - BN 180M	M5	FD 06		
BN 180L - NM 200L	—	FD 07		

(*) $t_{2c} < t_{2r} < t_2$

Le redresseur **SB** à contrôle électronique de l'excitation réduit les temps de déblocage du frein en surexcitant l'électro-aimant durant les premiers instants d'enclenchement pour passer ensuite au fonctionnement normal à demi-onde une fois le frein désactivé.

L'utilisation du redresseur type **SB** doit toujours être prévue dans les cas suivants :

- nombre d'interventions horaires élevé
- temps de déblocage frein réduits
- sollicitations thermiques du frein élevées

Pour les applications nécessitant un déblocage rapide du frein, sur demande les redresseurs **NBR** ou **SBR** sont disponibles.

Ces redresseurs complètent les types **NB** et **SB**, en intégrant dans le circuit électronique un interrupteur statique qui intervient en désexcitant rapidement le frein en cas de coupure de tension.

Cette solution permet de réduire les temps de déblocage du frein en évitant d'autres câblages et contacts extérieurs.

Pour une meilleure utilisation des redresseurs **NBR** et **SBR** l'alimentation séparée du frein est nécessaire.

Tensions disponibles : 230V ± 10%, 400V ± 10%, 50/60 Hz.

M6.3 Caractéristiques techniques freins FD

Le tableau suivant indique les caractéristiques techniques des freins en c.c. type FD.

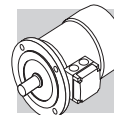

(F 30)

Frein	Couple de freinage M_b [Nm]			Déblocage		Freinage		W_{max} par freinage			W	P
	Ressorts			t_1	t_{1s}	t_2	t_{2c}	[J]				
	6	4	2	[ms]	[ms]	[ms]	[ms]	10 s/h	100 s/h	1000 s/h		
FD02	–	3.5	1.75	30	15	80	9	4500	1400	180	15	17
FD03	5	3.5	1.75	50	20	100	12	7000	1900	230	25	24
FD53	7.5	5	2.5	60	30	100	12					
FD04	15	10	5	80	35	140	15	10000	3100	350	30	33
FD14												
FD05	40	26	13	130	65	170	20	18000	4500	500	50	45
FD15	40	26	13	130	65	170	20					
FD55	55	37	18	–	65	170	20					
FD06S	60	40	20	–	80	220	25	20000	4800	550	70	55
FD56	–	75	37	–	90	250	20	29000	7400	800	80	65
FD06		100	50		100	250	20					
FD07	150	100	50	–	120	200	25	40000	9300	1000	130	65
FD08*	250	200	170	–	140	350	30	60000	14000	1500	230	100
FD09**	400	300	200	–	200	450	40	70000	15000	1700	230	120

* valeurs de couple de freinage obtenues respectivement avec n° 9, 7, 6 ressorts

** valeurs de couple de freinage obtenues respectivement avec n° 12, 9, 6 ressorts

t_1 = temps de déblocage du frein avec dispositif d'alimentation à demi-onde
 t_{1s} = temps de déblocage du frein avec dispositif d'alimentation à contrôle électronique de l'excitation
 t_2 = retard de freinage avec interruption côté c.a. et alimentation séparée
 t_{2c} = retard de freinage avec interruption côté c.a. et c.c. – Les valeurs de t_1 , t_{1s} , t_2 , t_{2c} indiquées dans le tab. (F30) se réfèrent au frein étalonné au couple maximal, entrefer moyen et tension nominale
 W_{max} = énergie max. par freinage
 W = énergie de freinage entre deux réglages successifs de l'entrefer
 P_b = puissance absorbée par le frein à 20 °C
 M_b = couple de freinage statique ($\pm 15\%$)
s/h = démarrages par heure

L'usure des plaquettes de frottement dépend des conditions de fonctionnement (température, humidité, vitesse de glissement, pression spécifique) ; les valeurs d'usure doivent donc être considérées comme fournies à titre indicatif.

M6.4 Raccordements frein FD

Les moteurs standard à une vitesse sont fournis avec le raccordement du redresseur au bornier moteur déjà réalisé en usine. Pour les moteurs à 2 vitesses, et lorsqu'une alimentation séparée du frein est requise, prévoir le raccordement au redresseur conformément à la tension frein VB indiquée sur la plaque signalétique du moteur.

Etant donné la nature inductive de la charge, pour la commande du frein et l'interruption côté courant continu, il est nécessaire d'utiliser des contacts avec catégorie d'utilisation AC-3 selon la norme IEC 60947-4-1.



Tableau (F31) - Alimentation frein depuis bornes moteur et interruption côté c.a.

Temps d'arrêt t_2 retardé et fonction des constantes de temps du moteur.

A prévoir lorsque des démarrages/arrêts progressifs sont requis.

Tableau (F32) - Bobine de frein avec alimentation séparée et interrupteur côté c.a.

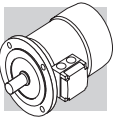
Temps d'arrêt normal et indépendant du moteur.

Les temps d'arrêts t_2 sont ceux indiqués dans le tableau (F30).

Tableau (F33) - Bobine de frein avec alimentation depuis les bornes moteur et interruption côté c.a. et c.c.

Arrêt rapide avec les temps d'intervention t_{2c} indiqués dans le tableau (F30).

Tableau (F34) - Bobine de frein avec alimentation séparée et interruption côté c.a. et c.c.

Temps d'arrêt réduit selon les valeurs t_{2c} indiquées dans le tableau (F30).

Les tableaux de (F31) à (F34) indiquent les schémas typiques de branchement pour une alimentation de 400 V, moteurs 230/400V raccordés en étoile et frein 230 V.

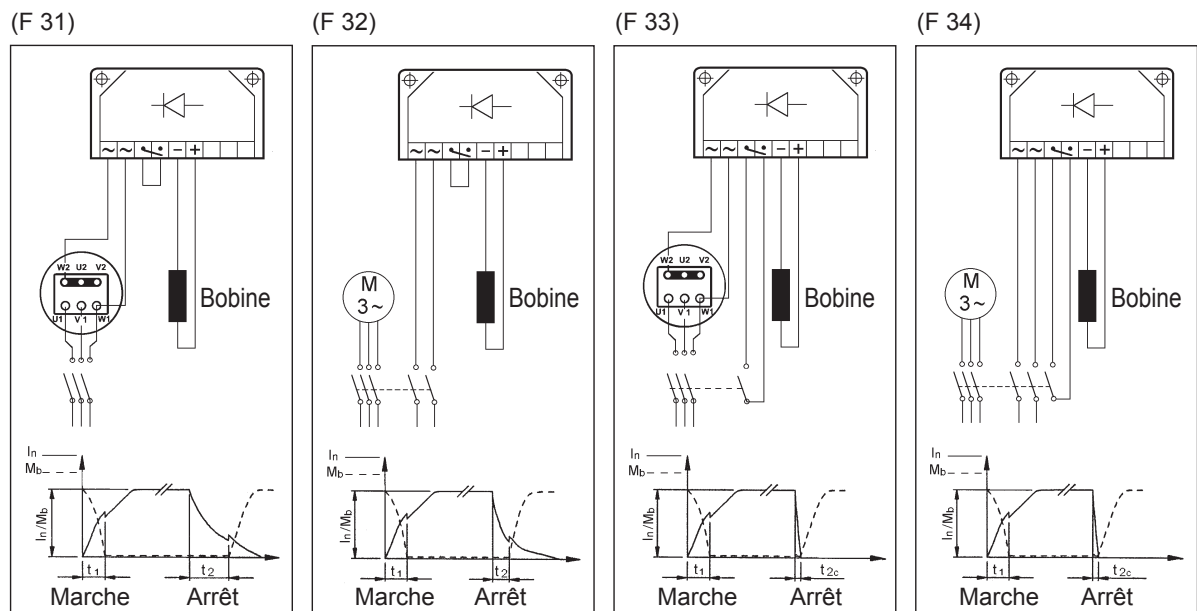

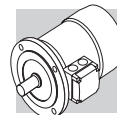

M7 MOTEURS FREIN EN C.C., TYPE BN_FD et M_AFD

Tailles : BN 63 ... BN 200L / M05 ... M5

(F 35)

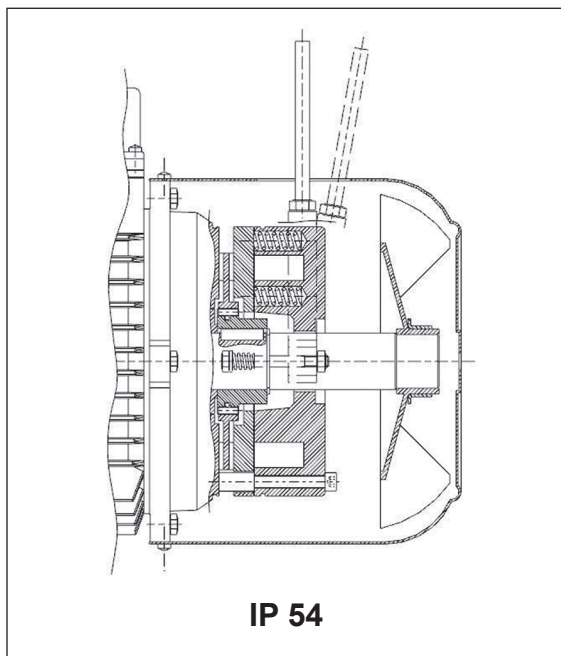

(F 36)

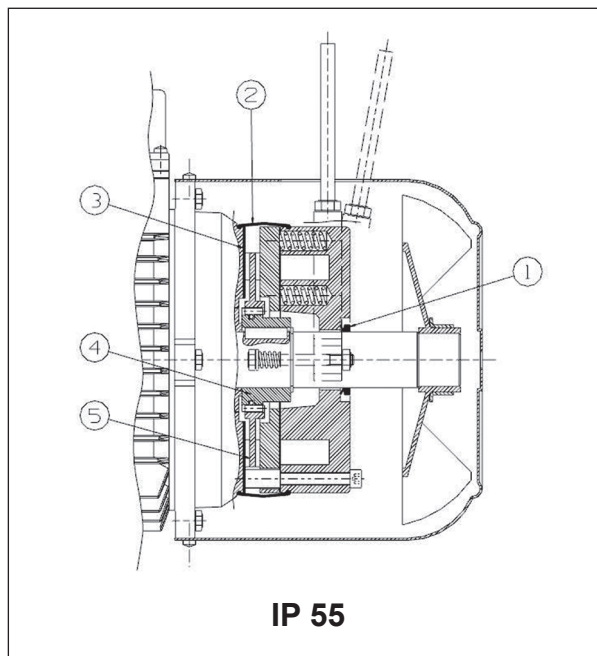

Frein à entrefer fixe, sans entretien jusqu'à l'usure maximale admissible pour la plaquette de frottement. L'entrefer est préétabli et ne doit pas être réglé.

Frein électromagnétique avec bobine toroïdale en **courant continu**, fixé avec des vis au bouclier moteur.

Le disque de frein coulisse sur le moyeu d'entraînement en acier calé sur l'arbre et doté d'un dispositif anti-vibration. Les moteurs sont fournis avec frein pré réglé en usine à la valeur de couple indiquée dans les tableaux des caractéristiques techniques ; le couple de freinage peut être réglé en modifiant le type et/ou le nombre de ressorts. Sur demande, les moteurs peuvent être équipés de levier pour le déblocage manuel avec retour automatique (**R**) ; pour la position angulaire du levier de déblocage, voir description de la variante correspondante au paragraphe "SYSTEMES DE DEBLOCAGE FREIN".

Le frein AFD garantit des performances dynamiques élevées et un faible niveau de bruit ; les caractéristiques d'intervention du frein en courant continu peuvent être optimisées en fonction de l'application en utilisant les différents types de dispositifs d'alimentation disponibles et/ou en réalisant un câblage approprié.

Le frein AFD est conseillé pour des applications dans lesquelles il est utilisé comme frein de stationnement.

Pour des applications qui prévoient des levages et/ou des valeurs élevées de travail horaire à écouler, contacter le service technique commercial.

M7.1 Degré de protection

L'exécution standard prévoit le degré de protection IP54.

En option, le moteur frein type AFD est fourni avec degré de protection **IP55**, en prévoyant les variantes de construction suivantes :

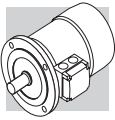

- ① abague V-ring positionnées sur l'arbre moteur N.D.E.
- ② bande de protection en caoutchouc
- ③ bague en acier inox interposée entre le bouclier moteur et le disque de frein
- ④ moyeu d'entraînement en acier inox
- ⑤ disque frein en acier inox



M7.2 Alimentation frein AFD

L'alimentation de la bobine de frein en c.c. est prévue au moyen d'un redresseur approprié monté à l'intérieur de la boîte à bornes et déjà câblé à la bobine de frein.

De plus, pour les moteurs à simple polarité, le raccordement du redresseur au bornier moteur est prévu de série.

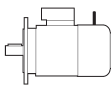

Indépendamment de la fréquence du réseau, la tension standard d'alimentation du redresseur V_B correspond à la valeur indiquée dans le tableau ci-dessous :

(F 37)

2, 4, 6 P				1 speed	
		BN_AFD / M_AFD		Alimentation frein depuis boîte à bornes	Alimentation séparée
		V_{mot} $\pm 10\%$ 3 ~	V_B $\pm 10\%$ 1 ~		
BN 63...BN 132	M05...M4LB	230/400 V – 50 Hz	230 V	standard	spécifier V_B SA ou V_B SD
BN 160MR	M4LC	400/690 V – 50 Hz	400 V	standard	spécifier V_B SA ou V_B SD

Pour les moteurs à double polarité, l'alimentation standard du frein dérive d'une ligne séparée avec tension d'entrée au redresseur V_B comme indiqué dans le tableau ci-dessous :

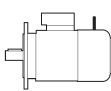
(F 38)

2/4, 2/6, 2/8, 2/12, 4/6, 4/8 P				2 speed	
		BN_AFD / M_AFD		Alimentation frein depuis boîte à bornes	Alimentation séparée
		V_{mot} $\pm 10\%$ 3 ~	V_B $\pm 10\%$ 1 ~		
BN 63...BN 132	M05...M4LB	400 V – 50 Hz	230 V		spécifier V_B SA ou V_B SD

Le redresseur est du type à diodes à demi-onde ($V_{c.c} \approx 0,45 \times V_{c.a.}$) et il est disponible dans les versions **SB** et **SBR**, comme indiqué de façon détaillée dans le tableau suivant :

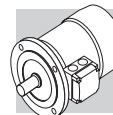

(F 39)

		frein			
				standard	Sur demande
BN 63	M05	AFD 02			
BN 71	M1	AFD 03			
BN 80	M2	AFD 04			
BN 90S	—	AFD 14			
BN 90L	—	AFD 05			
BN 100	M3	AFD 15			
BN 112	—	AFD 06S			
BN 132...160MR	M4	AFD 06			
		AFD 07			

(*) $t_{2c} < t_{2r} < t_2$

Le redresseur **SB** à contrôle électronique de l'excitation réduit les temps de déblocage du frein en surexcitant l'électro-aimant durant les premiers instants d'enclenchement pour passer ensuite au fonctionnement normal à demi-onde une fois le frein désactivé.

L'utilisation du redresseur type **SB** doit toujours être prévue dans les cas suivants :

- nombre d'interventions horaires élevé
- temps de déblocage frein réduits
- sollicitations thermiques du frein élevées

Pour les applications nécessitant un déblocage rapide du frein, sur demande les redresseurs **SBR** sont disponibles.

Ces redresseurs complètent les types **SB**, en intégrant dans le circuit électronique un interrupteur statique qui intervient en désexcitant rapidement le frein en cas de coupure de tension.

Cette solution permet de réduire les temps de déblocage du frein en évitant d'autres câblages et contacts extérieurs.

Pour une meilleure utilisation des redresseurs **SBR** l'alimentation séparée du frein est nécessaire.

Tensions disponibles : 230 Vca ± 10 %, 400 Vca ± 10 %, 50/60 Hz (avec alimentation) ; 100 Vcc ± 10 %, 180 Vcc ± 10 % (avec option SD).

M7.3 Caractéristiques techniques freins AFD

Le tableau suivant indique les caractéristiques techniques des freins en c.c. type AFD.

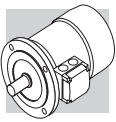

(F 40)

Frein	Couple de freinage M_b [Nm]			Entrefer		Déblocage t_{1s} [ms]	Freinage		W_{max} par freinage [J]			W [MJ]	P [W]
	Ressorts			t_{in} (± 0.1 mm)	t_{max}		t_2 [ms]	t_{2c} [ms]					
	6	4	2			10 s/h			100 s/h	1000 s/h			
AFD 02	—	3.5	1.8	0.3	0.7	20	110	10	4500	1400	160	40	15
AFD 03	7.5	5	2.5	0.3	0.7	35	140	15	7000	1900	210	60	21
AFD 04	15	10	5	0.4	0.8	55	180	15	11000	3100	350	75	27
AFD 14													
AFD 05	40	26	13	0.4	0.8	85	240	25	18000	4500	500	125	37
AFD 15													
AFD 06S	60	40	20	0.45	0.9	110	280	30	25000	6300	700	175	47
AFD 06	100	75(*) / 62(*)	37	0.45	0.9	130	330	30	29000	7400	800	200	50
AFD 07	150	100	50	0.45	0.95	170	350	30	40000	9300	1000	320	55

(*) en fonction du type de ressorts

t_{in} = entrefer avec le nouveau disque de frein

t_{max} = entrefer maximum pour lesquels il est nécessaire de remplacer le disque de frein

t_{1s} = temps de déblocage du frein avec dispositif d'alimentation à contrôle électronique de l'excitation

t_2 = retard de freinage avec interruption côté c.a. et alimentation séparée

t_{2c} = retard de freinage avec interruption côté c.a. et c.c. – Les valeurs de t_{1s} , t_2 , t_{2c} indiquées dans la table se réfèrent au frein étalonné au couple maximal, entrefer moyen et tension nominale

W_{max} = énergie max. par freinage

W = énergie de freinage dissipable avant le remplacement du disque de frein

P_b = puissance absorbée par le frein à 20 °C

M_b = couple de freinage statique ($\pm 15\%$)

s/h = démarrages par heure

L'usure des plaquettes de frottement dépend des conditions de fonctionnement (température, humidité, vitesse de glissement, pression spécifique) ; les valeurs d'usure doivent donc être considérées comme fournies à titre indicatif.

M7.4 Raccordements frein AFD

Les moteurs standard à une vitesse sont fournis avec le raccordement du redresseur au bornier moteur déjà réalisé en usine. Pour les moteurs à 2 vitesses, et lorsqu'une alimentation séparée du frein est requise, prévoir le raccordement au redresseur conformément à la tension frein VB indiquée sur la plaque signalétique du moteur.

Etant donné la nature inductive de la charge, pour la commande du frein et l'interruption côté courant continu, il est nécessaire d'utiliser des contacts avec catégorie d'utilisation AC-3 selon la norme IEC 60947-4-1.

Tableau (F41) - Alimentation frein depuis bornes moteur et interruption côté c.a.

Temps d'arrêt t_2 retardé et fonction des constantes de temps du moteur.

A prévoir lorsque des démarrages/arrêts progressifs sont requis.

Tableau (F42) - Bobine de frein avec alimentation séparée et interrupteur côté c.a.

Temps d'arrêt normal et indépendant du moteur.

Les temps d'arrêts t_2 sont ceux indiqués dans le tableau (F40).

Tableau (F43) - Bobine de frein avec alimentation depuis les bornes moteur et interruption côté c.a. et c.c.

Arrêt rapide avec les temps d'intervention t_{2c} indiqués dans le tableau (F40).

Tableau (F44) - Bobine de frein avec alimentation séparée et interruption côté c.a. et c.c.

Temps d'arrêt réduit selon les valeurs t_{2c} indiquées dans le tableau (F40).

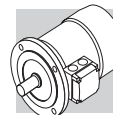

Les tableaux de (F41) à (F44) indiquent les schémas typiques de branchement pour une alimentation de 400 V, moteurs 230/400V raccordés en étoile et frein 230 V.

(F 41)

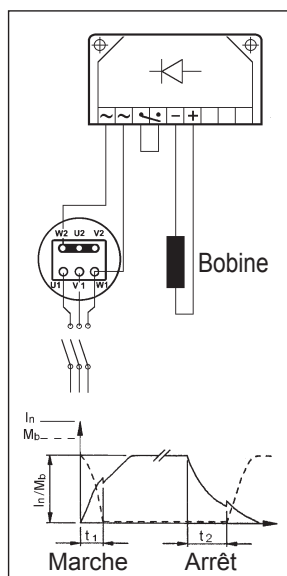

(F 42)

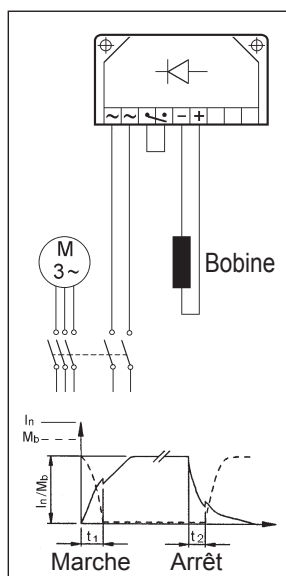

(F 43)

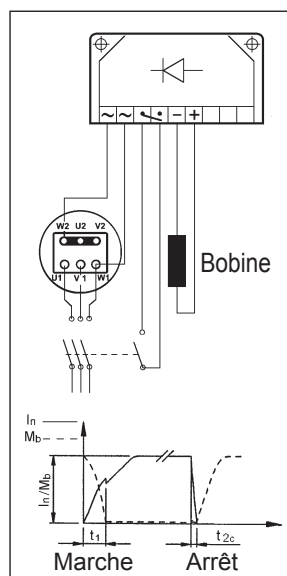

(F 44)

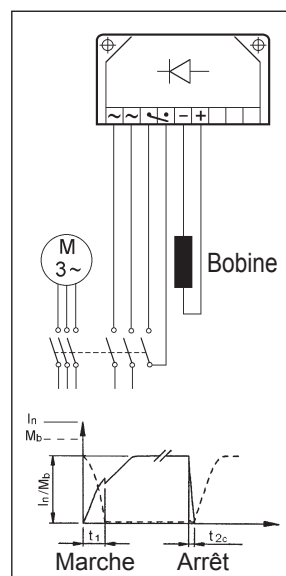

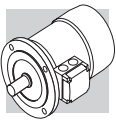

M8 MOTEURS FREIN EN C.A., TYPE BN_FA et M_FA

Tailles : BN 63 ... BN 180M / M05 ... M5

(F 45)

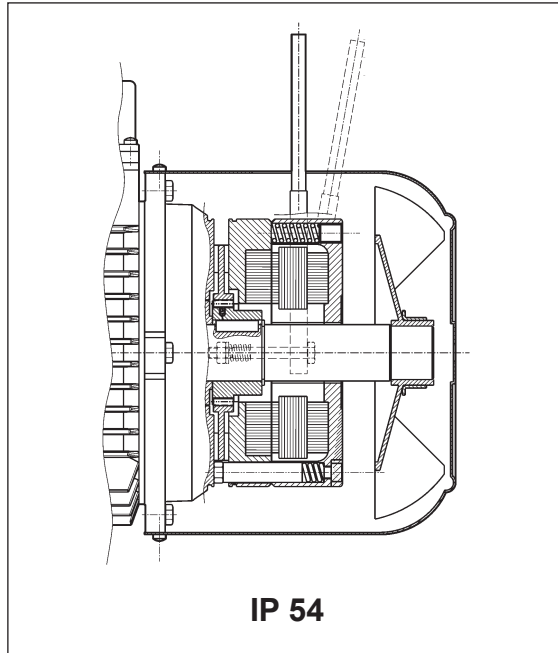

(F 46)

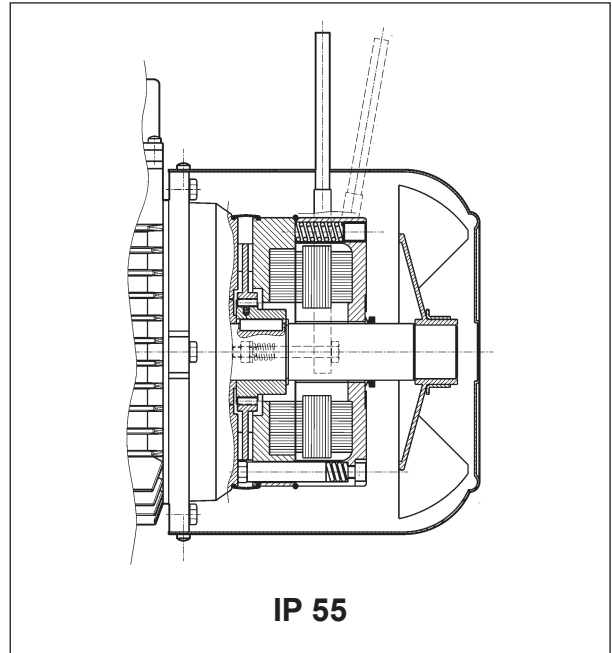

Frein électromagnétique avec alimentation en **courant alternatif** triphasé, fixé avec des vis au boulon ; les ressorts de précharge réalisent le positionnement axial de la bobine.

Le disque frein coulisse de façon axiale sur le moyeu d'entraînement en acier, calé sur l'arbre et doté d'un dispositif antivibration.

Le couple de freinage est pré réglé en usine aux valeurs qui sont indiquées dans les tableaux des caractéristiques techniques des moteurs correspondants. De plus, l'action du frein est modulable, en réglant le couple de freinage en continu au moyen des vis qui réalisent la précharge des ressorts ; la plage de réglage du couple est de $30\% M_{bMAX} < M_b < M_{bMAX}$ (M_{bMAX} est le couple de freinage maximum indiqué dans le tab. (F48).

Le frein type FA présente des caractéristiques dynamiques très élevées, il est donc adapté pour des applications nécessitant des fréquences de démarrage élevées et des temps d'intervention très rapides. Sur demande, les moteurs peuvent être prévus avec levier pour le déblocage manuel avec retour automatique (**R**). pour la position angulaire du levier de déblocage, voir description de la variante correspondante au paragraphe "SYSTEMES DE DEBLOCAGE FREIN".

Pour des applications qui prévoient des levages et/ou des valeurs élevées de travail horaire à écouler, contacter le service technique commercial.

M8.1 Degré de protection

L'exécution standard prévoit le degré de protection IP54.

En option, le moteur frein BN_FA est fourni avec degré de protection **IP55**, les variations de construction suivantes sont prévues

- bague V-ring positionnée sur l'arbre moteur N.D.E.
- bande de protection en caoutchouc
- joint torique

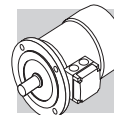

M8.2 Alimentation frein FA

Sur les moteurs à simple polarité, l'alimentation de la bobine frein dérive directement du bornier moteur, par conséquent, la tension du frein coïncide avec la tension du moteur. Dans ce cas, la tension du frein peut être omise de la désignation.

Pour les moteurs à double polarité et les moteurs avec alimentation séparée du frein, une boîte à bornes auxiliaire avec 6 bornes pour le raccordement à la ligne du frein, est présente. Dans les deux cas, la valeur de tension du frein doit être spécifiée dans la désignation.

Le tableau suivant indique les conditions d'alimentation standard du frein en c.a. pour les moteurs à simple et double polarité

(F 47)

Moteurs à simple polarité	BN 63...BN 132	BN 160...BN 180
	M05...M4LB	M4LC...M5
	230Δ / 400Y V ±10% – 50 Hz	400Δ/ 690Y V ±10% – 50 Hz
	265Δ / 460Y ±10% - 60 Hz	460Y – 60 Hz

Moteurs à double polarité (alimentation depuis ligne séparée)	BN 63...BN 132
	M05...M4
	230Δ / 400Y V ±10% – 50 Hz
	460Y - 60 Hz

Sauf spécification contraire, l'alimentation standard du frein est 230Δ /400Y V - 50 Hz.

Sur demande, des tensions spéciales sont disponibles dans la plage 24...690 V, 50-60 Hz.

M8.3 Caractéristiques techniques freins FA

(F 48)

Frein	Couple de freinage M_b [Nm]	Déblocage t_1 [ms]	Freinage t_2 [ms]	W_{max} [J]			W [MJ]	P [VA]
				10 s/h	100 s/h	1000 s/h		
FA 02	3.5	4	20	4500	1400	180	15	60
FA 03	7.5	4	40	7000	1900	230	25	80
FA 04	15	6	60	10000	3100	350	30	110
FA 14								
FA 05	40	8	90	18000	4500	500	50	250
FA 15								
FA 06S	60	16	120	20000	4800	550	70	470
FA 06	75	16	140	29000	7400	800	80	550
FA 07	150	16	180	40000	9300	1000	130	600
FA 08	250	20	200	60000	14000	1500	230	1200

M_b = couple de freinage statique max ($\pm 15\%$)
 t_1 = temps de déblocage frein
 t_2 = retard de freinage
 W_{max} = énergie max par freinage (capacité thermique du frein)
W = énergie de freinage entre deux réglages successifs de l'entrefer
 P_b = puissance absorbée par le frein à 20° (50 Hz)
s/h = démarrages par heures

N.B.
Les valeurs de t_1 et t_2 indiquées dans le tableau se réfèrent au frein étalonné au couple nominal, entrefer moyen et tension nominale.

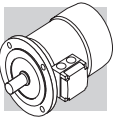

L'usure des plaquettes de frottement dépend des conditions de fonctionnement (température, humidité, vitesse de glissement, pression spécifique) ; les valeurs d'usure doivent donc être considérées comme fournies à titre indicatif.

M8.4 Raccordements frein FA

Pour les moteurs avec alimentation du frein dérivant directement de l'alimentation moteur, les raccordements à la boîte à bornes correspondent aux indications du schéma (F49) :

(F 49)

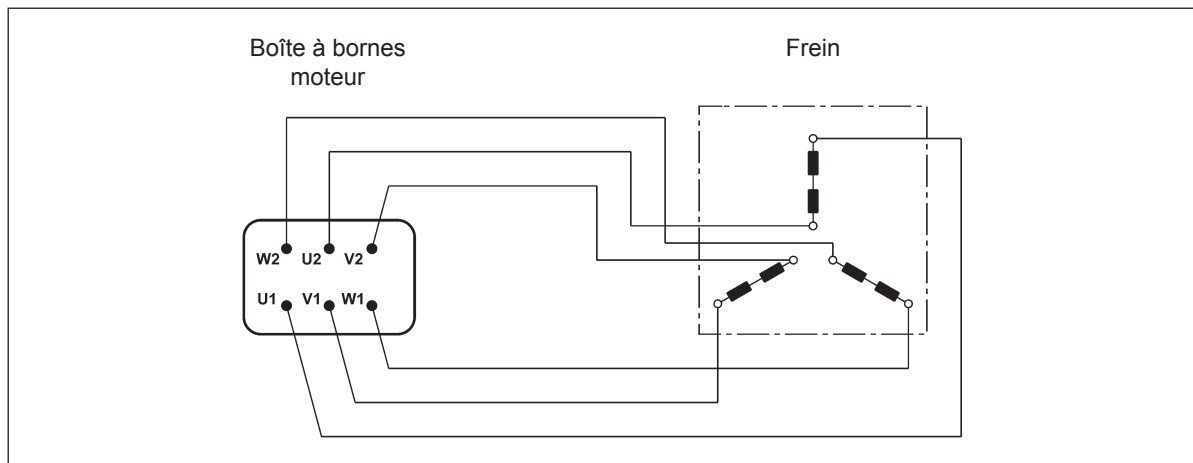

Pour les moteurs à double polarité et, lorsque cela est requis, pour les moteurs à une vitesse avec alimentation depuis une ligne séparée, une boîte à bornes auxiliaire à 6 bornes est prévue pour le raccordement du frein ; dans cette exécution les moteurs prévoient un couvercle bornier majoré. Voir schéma (F50) :

(F 50)

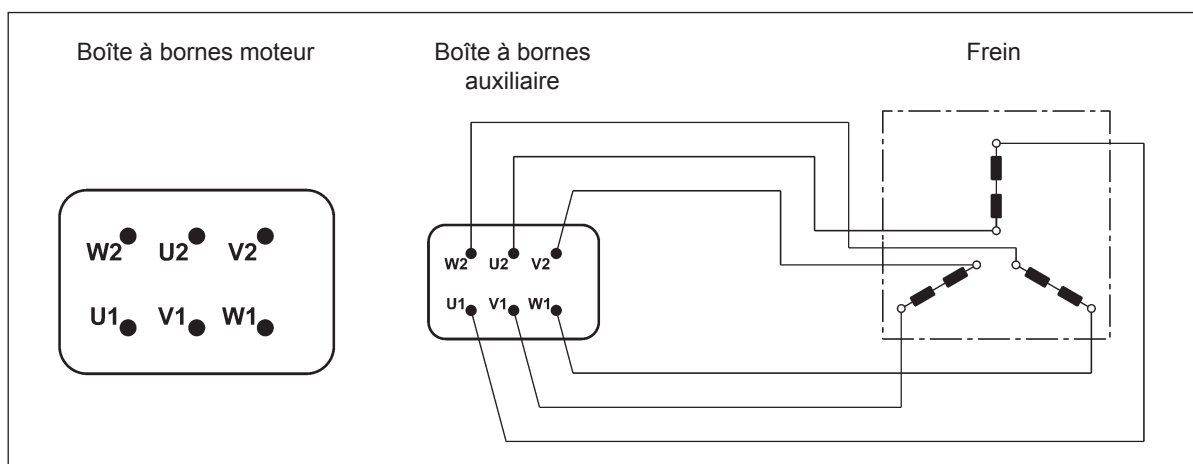

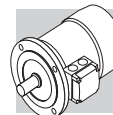

M9 MOTEURS FREIN EN C.A., TYPE BN_BA

Tailles : BN 63 ... BN 132M

(F 51)

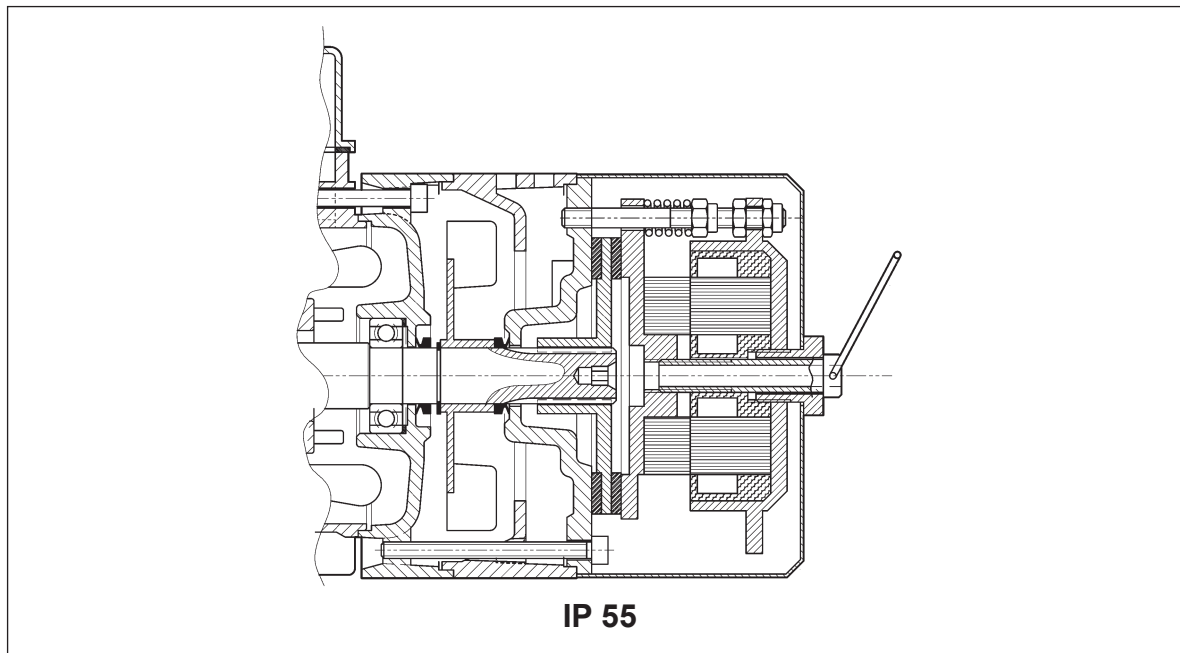

Frein électromagnétique avec alimentation en **courant alternatif** triphasé, fixé avec des vis au boulon.

Disque frein en acier coulissant de façon axiale sur l'arbre moteur claveté (moyeu d'entraînement en acier calé sur l'arbre pour la taille 244).

Les moteurs sont fournis avec frein étalonné au couple maximal.

Le couple de freinage est réglable en continu en intervenant sur les vis de compression des ressorts ; la plage de réglage autorisée est de $30\% M_{bMAX} < M_b < M_{bMAX}$ (M_{bMAX} étant le couple de freinage maximum indiqué dans le tab. (F53).

De série, les moteurs sont fournis avec vis de déblocage manuel du frein, avec maintien de la position de relâchement afin de permettre la rotation de l'arbre moteur.

La vis de déblocage doit être démontée après utilisation afin de garantir le fonctionnement correct du frein et d'éviter les situations potentiellement dangereuses.

Le frein BA, outre les caractéristiques dynamiques élevées typiques des freins en courant alternatif, est de fabrication robuste avec énergie de freinage majorée, ce qui le rend particulièrement adapté pour les services difficiles ainsi que pour les applications nécessitant des fréquences de manœuvre élevées et des temps d'intervention très rapides.

Pour des applications qui prévoient des levages et/ou des valeurs élevées de travail horaire à écouler, contacter le service technique commercial.

M9.1 Degré de protection

Il est disponible en une exécution unique, avec degré de protection IP55.

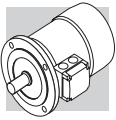

M9.2 Alimentation frein BA

Sur les moteurs à simple polarité, l'alimentation de la bobine frein dérive directement du bornier moteur, par conséquent, la tension du frein coïncide avec la tension du moteur. Dans ce cas, la tension du frein peut être omise de la désignation.

Pour les moteurs à double polarité et les moteurs avec alimentation séparée du frein, un boîte à bornes auxiliaire avec 6 bornes pour le raccordement au réseau du frein, est présente. Dans les deux cas, la valeur de tension du frein doit être spécifiée dans la désignation.

Le tableau suivant indique les conditions d'alimentation standard du frein en c.a. pour les moteurs à simple et double polarité :

(F 52)

Moteurs à simple polarité	BN 63 ... BN 132	
	230Δ / 400Y V ±10% – 50 Hz	
	265Δ / 460Y ±10% - 60 Hz	
Moteurs à double polarité (alimentation depuis ligne séparée)	BN 63 ... BN 132	
	230Δ / 400Y V ±10% – 50 Hz	
	460Y - 60 Hz	

Sauf spécification contraire, l'alimentation standard du frein est 230Δ /400Y V - 50 Hz.

Sur demande, des tensions spéciales sont disponibles dans la plage 24...690 V, 50-60 Hz.

M9.3 Caractéristiques techniques freins BA

Le tableau ci-dessous indique les caractéristiques techniques des freins en c.a., type BA.

(F 53)

Frein	Couple de freinage M_b [Nm]	Déblocage t_1 [ms]	Freinage t_2 [ms]	W_{max} [J]			W [MJ]	P_B [VA]
				10 s/h	100 s/h	1000 s/h		
BA 60	5	5	20	4000	1500	180	30	60
BA 70	8	6	25	7000	2700	300	60	75
BA 80	18	6	25	10000	3100	350	80	110
BA 90	35	8	35	13000	3600	400	88	185
BA 100	50	8	35	18000	4500	500	112	225
BA 110	75	8	35	28000	6800	750	132	270
BA 140	150	15	60	60000	14000	1500	240	530

M_b = couple de freinage statique max ($\pm 15\%$)
 t_1 = temps de déblocage frein
 t_2 = retard de freinage
 W_{max} = énergie max par freinage (capacité thermique du frein)
 W = énergie de freinage entre deux réglages successifs de l'entrefer
 P_b = puissance absorbée par le frein à 20° (50 Hz)
 s/h = démarrages par heures

N.B.
 Les valeurs de t_1 et t_2 indiquées dans le tableau se réfèrent au frein étalonné au couple nominal, entrefer moyen et tension nominale.

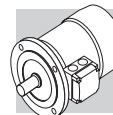

L'usure des plaquettes de frottement dépend des conditions de fonctionnement (température, humidité, vitesse de glissement, pression spécifique) ; les valeurs d'usure doivent donc être considérées comme fournies à titre indicatif.

M9.4 Raccordements frein BA

Pour les moteurs avec alimentation du frein dérivant directement de l'alimentation moteur, les raccordements à la boîte à bornes correspondent aux indications du schéma (F54) :

(F 54)

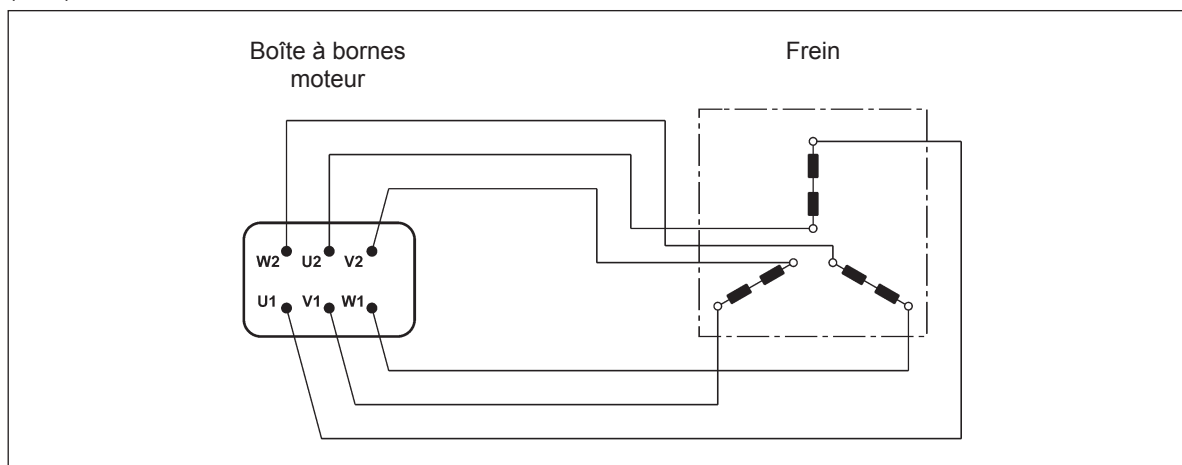

Pour les moteurs à double polarité et, lorsque cela est requis, pour les moteurs à une vitesse avec alimentation depuis ligne séparée, une boîte à bornes auxiliaire à 6 bornes est prévue pour le raccordement du frein ; dans cette exécution les moteurs prévoient un couvercle bornier majoré. Voir schéma (F55) :

(F 55)

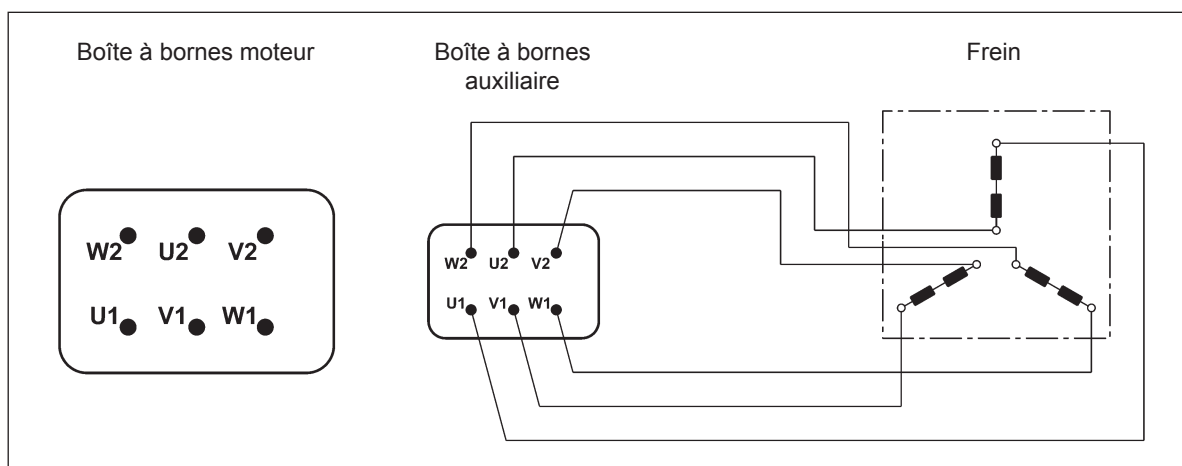

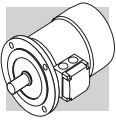

M10 SYSTEMES DE DEBLOCAGE FREIN

Les freins à pression de ressorts type FD, AFD et FA peuvent, en option, être dotés de dispositifs de déblocage manuel du frein, normalement utilisés pour effectuer des interventions d'entretien sur les composants de la machine, ou de l'installation commandée par le moteur.

(F 56)

R

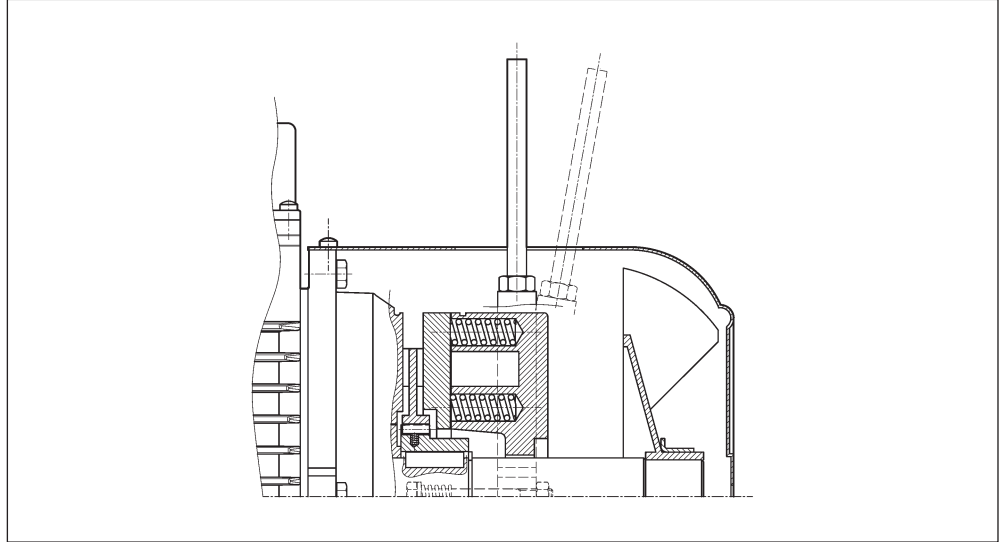

Le levier de déblocage est doté d'un retour automatique, au moyen d'un dispositif à ressort.

(F 57)

RM

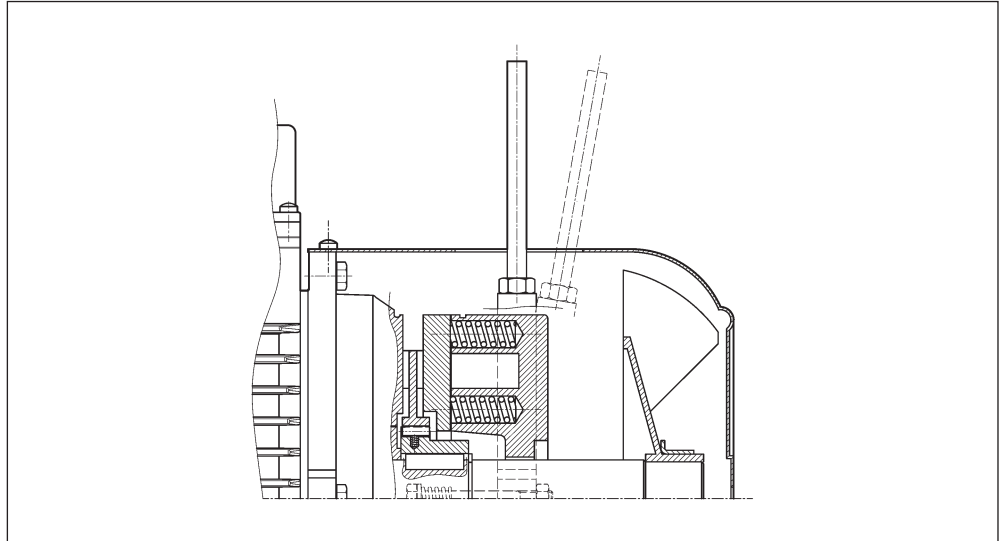

Levier de déblocage peut être temporairement bloqué en position de déblocage du frein en le vissant jusqu'à engager l'extrémité dans une saillie du corps du frein.

La disponibilité des systèmes de déblocage du frein est différente en fonction des types de moteur et figure dans le tableau suivant.

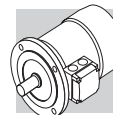

(F 58)

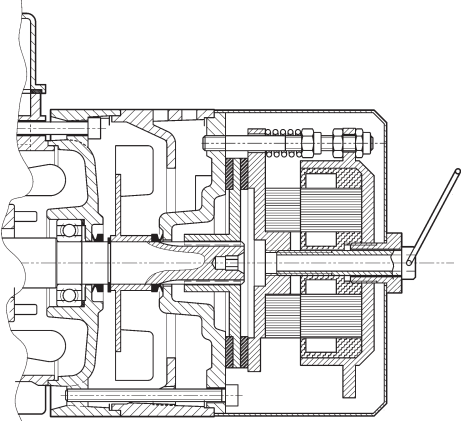
	R	RM
BN_FD	BN 63...BN 200	2p 63A2 ≤ H ≤ 132M2 4p 63A4 ≤ H ≤ 132MA4 6p 63A6 ≤ H ≤ 132MA6
BN_AFD	BN 63...BN 160MR	⊖
M_FD	M 05...M 5	M 05...M 4LA
M_AFD	M 05...M 4LC	⊖
BN_FA	BN 63...BN 180M	⊖
M_FA	M 05...M 5	
BN_BA		

M10.1 Orientation du levier de déblocage

Pour les deux options **R** et **RM**, le levier de déblocage du frein est positionné, sauf spécification contraire, avec une orientation de 90° dans le sens des aiguilles d'une montre par rapport à la position de la boîte à bornes - référence **[AB]** sur le dessin ci-dessous.

Des orientations différentes, type **[AA]**, **[AC]** et **[AD]** peuvent être demandées à condition de préciser la position correspondante :

(F 59)

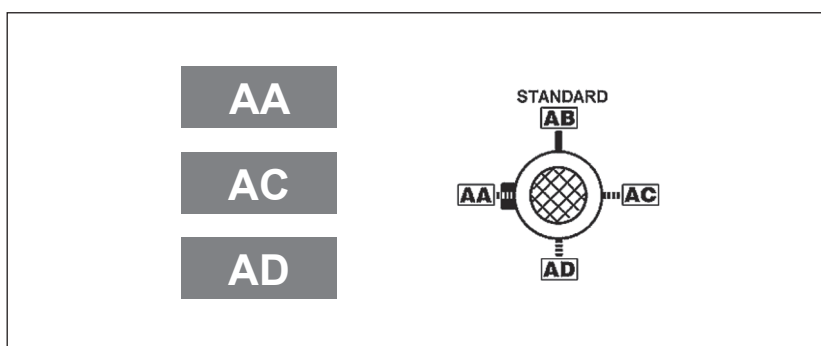

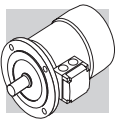

M10.2 Caractéristiques volants (F1)

Le tableau suivante indique le poids et l'inertie des volants supplémentaires sans variations de l'encombrement moteur.



(F 60)

Données volant pour moteurs type: BN_FD, M_FD			
		Poids volant [Kg]	Inertie volant [Kgm ²]
BN 63	M05	0.69	0.00063
BN 71	M1	1.13	0.00135
BN 80	M2	1.67	0.00270
BN 90 S - BN 90 L	–	2.51	0.00530
BN 100	M3	3.48	0.00840
BN 112	–	4.82	0.01483
BN 132 S - BN 132 M	M4	6.19	0.02580

M11 OPTIONS

M11.1 Protections thermiques

Outre la protection garantie par l'interrupteur magnétothermique, les moteurs peuvent être équipés de sondes thermiques incorporées pour protéger le bobinage contre une surchauffe excessive due par exemple à une ventilation insuffisante ou un service intermittent.

Cette protection devrait toujours être prévue pour les moteurs servoventilés (IC416).

M11.2 Sondes thermométriques

E3

Ce sont des semiconducteurs qui présentent une variation rapide de résistance à proximité de la température nominale d'intervention (150 °C).

L'évolution de la caractéristique $R = f(T)$ est défini par les Normes DIN 44081, IEC 34-11.

En général, on utilise des thermistors à coefficient de température positif dénommés également "résistors à conducteur froid" PTC.

Les thermistances ne peuvent pas commander directement les relais et doivent donc être branchées à un appareil de déclenchement adapté.

Avec cette protection, trois sondes (reliées en série), sont insérées dans le bobinage avec extrémités disponibles dans le bornier auxiliaire.

K1

Il s'agit d'un sous-groupe des thermistances PTC, dont les caractéristiques de construction permettent de les utiliser en tant que capteurs de température ayant un coefficient de température positif en fonction de la résistance.

La température d'exploitation est de : 0 °C ... +260 °C.

Les thermistances ne peuvent pas commander directement les relais et doivent donc être branchées à un appareil de déclenchement adapté.

Les bornes (polarisées) d'1 KTY 84-130 sont disponibles dans un bornier auxiliaire.

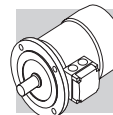

M11.3 Sondes thermiques bimétalliques

D3

Les protecteurs de ce type contiennent, dans une enveloppe interne, un disque bimétallique qui, lorsque la température nominale d'intervention (150 °C) est atteinte, commute les contacts de la position de repos.

Avec la diminution de la température, le disque et les contacts reprennent automatiquement la position de repos.

Normalement, on utilise trois sondes bimétalliques en série avec contacts normalement fermés et extrémités disponibles dans un bornier auxiliaire.

M11.4 Moteur avec connecteur

CON

Trois types de connecteurs sont disponibles (CON 1, CON 2, CON 3), qui peuvent être installés dans deux positions de montage : côté droit boîtier couvre-bornier (C1D, C2D, C3D) ; côté gauche boîtier couvre-bornier (C1S, C2S, C3S).

L'option CON est prévue pour les moteurs BN et M à polarité unique (2, 4, 6, 8, pôles) dans les grandeurs indiquées dans le tableau suivant. Toutes les versions à double polarité sont exclues.

Les connecteurs sont disponibles pour les moteurs BN et M dans la version sans frein et pour les moteurs autofreinants BN et M dotés d'un frein à courant continu FD ou AFD, dans les grandeurs indiquées dans le tableau suivant.

Le connecteur mâle (doté d'une fiche) est fixé sur le moteur, le connecteur femelle est exclu de la fourniture.

Avec l'option CON, le branchement en Y des phases est toujours prévu.

Pour des moteurs dotés d'une servo-ventilation (option U1), l'alimentation du ventilateur est prévue dans le boîtier de bornier séparé, fixé à l'enveloppe du ventilateur.

Dans les moteurs dotés d'un encodeur (options EN1...EN6), la connexion de l'encodeur se fait par le biais d'un câble volant non connecté au connecteur.

L'option CON n'est pas applicable aux moteurs dotés d'un frein en courant alternatif FA, BA.

L'option CON n'est pas compatible avec les options U2, CUS, IC.

Caractéristiques techniques

(F 61)

Option	CON 1
Taille moteur	BN63...BN112 / M05...M3
Vue connecteur	
Type de connecteur	Harting Han 10ES
Corps connecteur	Han EMC 10B avec 2 leviers
Nombre de broches - courant nominal	10 x 16A
Tension d'alimentation	500 Vac
Type de connexion contacts	Bornes avec vis

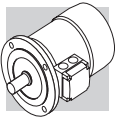

(F 62)

Option	CON 2
Taille moteur	BN63...BN160MR / M05...M4LC
Vue connecteur	
Type de connecteur	Harting Han Modular
Corps connecteur	Han EMC 10B avec 2 leviers
Type de Modules	Module C + Module vide + Module E
Nombre de broches - courant nominal	3 x 36A / 6 x 16A
Tension d'alimentation	500 Vac
Type de connexion contacts	Contacts à sertir

(F 63)

Option	CON 3
Taille moteur	BN63...BN160MR / M05...M4LC
Vue connecteur	
Type de connecteur	Harting Han Modular
Corps connecteur	Han EMC 10B avec 2 leviers
Type de Modules	Module C + Module E + Module E
Nombre de broches - courant nominal	3 x 36A / 6 + 6 x 16A
Tension d'alimentation	500 Vac
Type de connexion contacts	Contacts à sertir

(F 64)

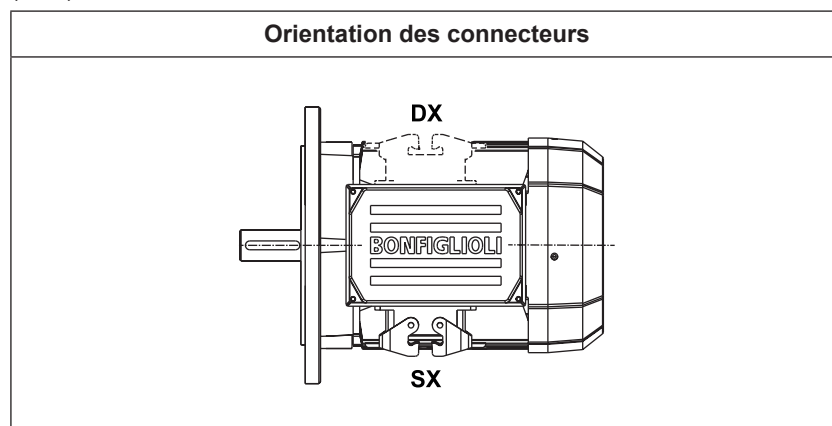

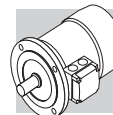

(F 65)

Dimensions d'encombrement moteurs sans frein						
		AD (mm)	AF (mm)	AH (mm)	LL (mm)	V(*) (mm)
BN63	M05	136	110	45	165	4.5
BN71	M1	149	110	45	165	15.5
BN80	M2	160	110	45	165	16.5
BN90	—	162	110	45	165	31.5
BN100	M3	171	110	45	165	37.5
BN112	—	186	110	45	165	39
BN132	M4	210	140	45	188	45.5
BN160MR	—	210	140	45	188	161

(*) Dimension valide uniquement pour les moteurs BN.

(F 66)

Dimensions d'encombrement moteurs avec frein FD						
		AD (mm)	AF (mm)	AH (mm)	LL (mm)	V(*) (mm)
BN63	M05	136	110	45	165	4.5
BN71	M1	149	110	45	165	1.5
BN80	M2	160	110	45	165	18.5
BN90	—	162	110	45	165	39.5
BN100	M3	171	110	45	165	63.5
BN112	—	186	110	45	165	75
BN132	M4	210	140	45	188	122
BN160MR	—	210	140	45	188	161

(*) Dimension valide uniquement pour les moteurs BN.

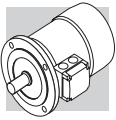

M11.5 Contrôle de la fonctionnalité du frein

MSW

Le micro-interrupteur peut être réglé pour signaler l'attraction/le relâchement de l'ancre mobile ou pour signaler que la valeur maximale admissible pour l'entrefer est atteinte.

L'option MSW est disponible pour les freins FD03...FD09 et AFD03...AFD07.

Le micro-interrupteur est doté de trois bornes NC, NO, COM. Sur la figure ci-dessous sont représentés les principaux composants du frein équipé du micro-interrupteur.

(F 67)

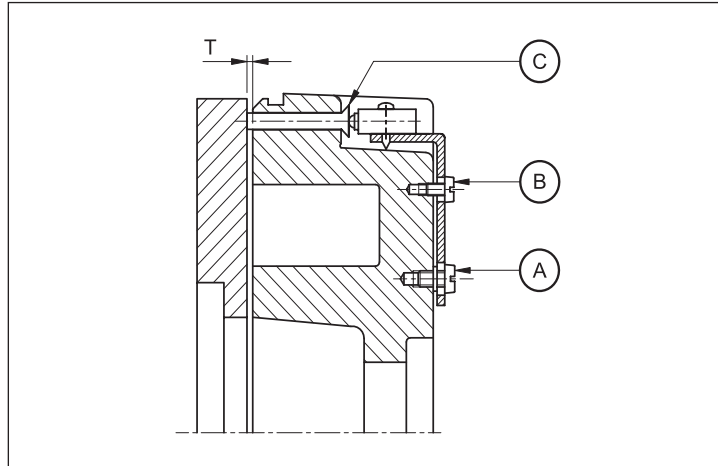

- A: Vis de fixation
- B: Vis de réglage
- C: Actionneur

M11.6 Entrée de câbles supplémentaire pour moteurs autofreinants

IC

Sur le boîtier couvre-bornier des moteurs autofreinants BN63...BN160MR / M05...M4, il existe deux entrées de câble supplémentaires M16 x 1,5 (une par côté).

Sur le boîtier couvre-bornier des moteurs autofreinants BN160...BN200 / M5, il existe une entrée de câble supplémentaire M16 x 1,5 à côté de l'entrée de câble de frein.

M11.7 Réchauffeurs anticondensation

H1



Les moteurs fonctionnant dans des milieux très humides et/ou en présence de fortes plages thermiques peuvent être équipés d'une résistance anticondensation.

L'alimentation monophasée est prévue par l'intermédiaire d'une boîte à bornes auxiliaire située dans la boîte principale.

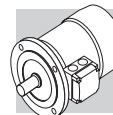
Les puissances absorbées sont indiqués ci-dessous :



(F 68)

			H1
			1~ 230V ± 10% P [W]
BN 56...BN 80		M0...M2	10
BN 90...BN 160MR		M3 - M4	25
BN 160M...BN 180M		M5	50
BN 180L...BN 200L		—	50

Avertissement! Durant le fonctionnement du moteur, la résistance anticondensation ne doit jamais être alimentée.

M11.8 Arbre à double extrémité

PS

L'option exclut les variantes RC, TC, U1, U2, EN1, EN2, EN3, EN4, EN5, EN6 – non applicables aux moteurs avec frein type BA.

Les dimensions figurent sur les planches de dimensions des moteurs.

(F 69)

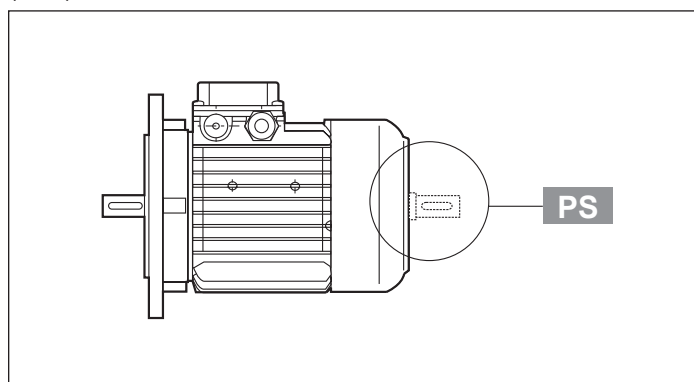

M11.9 Dispositif anti-retour

AL

AR

Pour les applications où il est nécessaire d'empêcher la rotation inverse du moteur à cause de l'action de la charge, il est possible d'utiliser des moteurs dotés d'un dispositif anti-retour (disponible seulement sur la série M).

Ce dispositif, bien que permettant la libre rotation dans le sens de marche, intervient instantanément en cas de manque d'alimentation en bloquant la rotation de l'arbre dans le sens inverse.

Le dispositif anti-retour est lubrifié à vie avec une graisse spécifique pour cette application.

En phase de commande, il faudra indiquer clairement le sens de marche prévu. En aucun cas, le dispositif anti-retour ne devra être utilisé pour empêcher la rotation inverse en cas de branchement électrique erroné.

Le tableau (F70) indique le couple nominal et le couple maximum de blocage attribués aux dispositifs anti-retour utilisés alors que la représentation schématique du dispositif se trouve dans le tableau (F71). Les dimensions sont les mêmes que celles d'un moteur frein.

Le sens de rotation libre est décrit au paragraphe "OPTIONS MOTEURS" dans les sections spécifiques dédiées aux réducteurs.

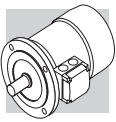

(F 70)

	Couple nominal de blocage	Couple maxi. de blocage	Vitesse de décolllement
	[Nm]	[Nm]	[min ⁻¹]
M1	6	10	750
M2	16	27	650
M3	54	92	520
M4	110	205	430

(F 71)

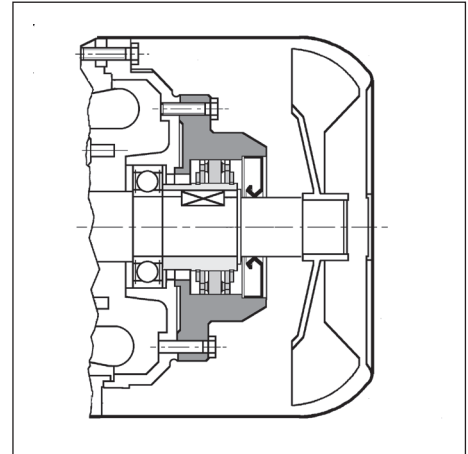

M11.10 Ventilation

Les moteurs sont refroidis par ventilation externe (IC 411 selon CEI EN 60034-6) et sont équipés d'un ventilateur radial en plastique fonctionnant dans les deux sens de rotation.



L'installation doit garantir une distance minimum de la capot cache-ventilateur par rapport au mur le plus proche de façon à ne pas créer d'empêchement à la circulation de l'air ainsi que pour permettre les interventions d'entretien ordinaire du moteur et, si présent, du frein.

Sur demande, à partir de la taille BN 71, ou M1, les moteurs peuvent être fournis avec ventilation forcée à alimentation indépendante. Le refroidissement est réalisé au moyen d'un ventilateur axial avec alimentation indépendante monté sur la capot cache-ventilateur (méthode de refroidissement IC 416).

Cette exécution est utilisée en cas d'alimentation du moteur par variateur dans le but d'étendre aussi la plage de fonctionnement à couple constant aux faibles vitesses ou lorsque des fréquences de démarrage élevées sont nécessaire à celui-ci.

Les moteurs frein type BN_BA et les moteurs avec arbre sortant des deux côtés (option PS) SP sont exclus de cette option.



(F 72)

Données d'alimentation					
		V a.c. ± 10%	Hz	P [W]	I [A]
BN 71	M1	1~ 230	50 / 60	22	0.12
BN 80	M2			22	0.12
BN 90	—			40	0.30
BN 100 (*)	M3			50	0.25
BN 112	—	3~ 230 Δ / 400Y	50	50	0.26 / 0.15
BN 132S	M4S			110	0.38 / 0.22
BN 132M...BN 160MR	M4L				
BN 160...BN 180M	M5			180	1.25 / 0.72

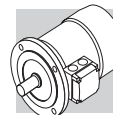
Pour la variante sont disponibles deux exécutions alternatives, dénommées **U1** et **U2**, ayant le même encombrement dans le sens longitudinal. Pour les deux exécutions, la majoration de la longueur du capot cache-ventilateur (**DL**) est indiquée dans le tableau suivant. Dimensions totales à calculer d'après les planches de dimensions des moteurs.



(F 73)

Tableau majoration longueurs moteur			
		ΔL_1	ΔL_2
BN 71	M1	93	32
BN 80	M2	127	55
BN 90	—	131	48
BN 100	M3	119	28
BN 112	—	130	31
BN 132S	M4S	161	51
BN 132M	M4L	161	51

ΔL_1 = variation de dimension par rapport à la cote LB du moteur standard correspondant

ΔL_2 = variation de dimension par rapport à la cote LB du moteur frein correspondant

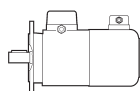
U1

Bornes d'alimentation du ventilateur dans un bornier séparé.

Pour les moteurs frein taille BN 71...BN 160MR, avec variante **U1**, le levier de déblocage ne peut être installé en position AA.

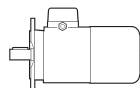

L'option n'est pas disponible pour les moteurs conformes aux normes CSA et UL (option CUS).

U2

Bornes d'alimentation du ventilateur dans le bornier principal du moteur.

L'option n'est pas applicable aux moteurs BN 160...BN 200L, sauf pour les moteurs BN 160MR, pour lesquels l'option est disponible et aux moteurs avec l'option CUS (conforme aux normes CSA et UL).

(F 74)

(*)			V a.c. $\pm 10\%$	Hz	P [W]	I [A]
	BN 100_U2	M3	3~ 230 Δ / 400Y	50 / 60	40	0.12 / 0.09



M11.11 Capot de protection anti-pluie

RC

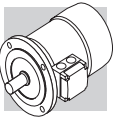
Le capot de protection antipluie est recommandé lorsque le moteur est monté verticalement avec l'arbre vers le bas, il sert à protéger le moteur contre l'introduction de corps solides et le suintement. Les dimensions à ajouter sont indiquées dans le tableau suivant. Le capot antipluie exclut les variantes PS, EN1, EN2, EN3, EN4, EN5, EN6 et n'est pas applicable aux moteurs avec frein type BA.

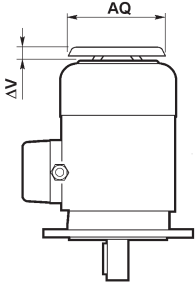

(F 75)

		AQ	ΔV	
BN 63	M05	118	24	
BN 71	M1	134	27	
BN 80	M2	152	25	
BN 90	—	168	30	
BN 100	M3	190	28	
BN 112	—	211	32	
BN 132...BN 160MR	M4	254	32	
BN 160M...BN 180M	M5	302	36	
BN 180L...BN 200L	—	340	36	

M11.12 Capot textile

TC

La variante du capot type TC est à spécifier lorsque le moteur est installé dans des sites de l'industrie textile, où sont présents des filaments qui pourraient obstruer la grille du cache-ventilateur et empêcher le flux régulier de l'air de refroidissement.

L'option exclut les variantes EN1, EN2, EN3, EN4, EN5, EN6 et n'est pas applicable aux moteurs avec frein type BA. L'encombrement total est identique à celui du capot type RC.

M11.13 Dispositifs de retroaction

Pour moteurs peuvent être dotés de trois types de codeurs différents, décrits ci-après.

Le montage du codeur exclut les exécutions avec arbre à double extrémité (PS) et le capot de protection (RC, TC).

Le dispositif n'est pas applicable aux moteurs avec frein en c.a., type BA.

EN1

Codeur incrémental, $V_{IN} = 5 V$, sortie line-driver RS 422.

EN2

Codeur incrémental, $V_{IN} = 10-30 V$, sortie line-driver RS 422.

EN3

Codeur incrémental, $V_{IN} = 12-30 V$, sortie push-pull 12-30 V.

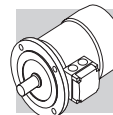

EN4

Encodeur sin/cos, $V_{IN} = 4,5-5,5$ V, sortie sinus $0,5 V_{PP}$.

EN5

Encodeur absolu monotour, interface HIPERFACE®, $V_{IN} = 7-12$ V.

EN6

Encodeur absolu multitour, interface HIPERFACE®, $V_{IN} = 7-12$ V.

(F 76)

	EN1	EN2	EN3	EN4	EN5	EN6
interface	TTL/RS 422	TTL/RS 422	HTL/push-pull	Sinus 0.5 VPP	HIPERFACE®	HIPERFACE®
tension d'alimentation [V]	4...6	10...30	12...30	4.4...5.5	7...12	7...12
tension de sortie [V]	5	5	12...30	—	—	—
courant d'utilisation sans charge [mA]	120	100	100	40	80	80
nbre d'impulsions par tour	1024					
positions de rotation	—	—	—	—	15 bit	15 bit
révolutions	—	—	—	—	—	12 bit
nbre de signaux	6 (A, B, Z + signaux inversés)			6 (cos-, cos+, sin-, sin+, Z, \bar{Z})	—	—
fréquence max. de sortie [kHz]	600			200		
vitesse max. [min ⁻¹]	6000 (9000 min ⁻¹ pour 10 s)					
gamme de température de fonctionnement [°C]	-30 ... +100					
degré de protection	IP 65					

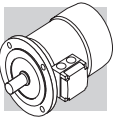

(F 78)

EN1, EN2, EN3, EN4, EN5, EN6	
BN 63...BN 200L	M05...M5
BN 63_FD...BN 200L_FD	M05_FD...M5_FD
BN 63_AFD...BN 160MR_AFD	M05_AFD...M4LC_AFD
BN 63_FA...BN 200L_FA	M05_FA...M5_FA

(F 77)

EN_ + U1		
BN 160M...BN 180M	M5	L3 72
BN 180L...BN 200L	-	82
BN 160M_FD...BN 180M_FD	M5_FD	35
BN 180L_FD...BN 200L_FD	-	41

Si un codeur (option EN_) est nécessaire sur les moteurs de tailles BN71...BN160MR / M1...M4, en association avec la ventilation forcée (options U1, U2), la variation de dimensions du moteur coïncide avec celle des exécutions U1 et U2 correspondantes.

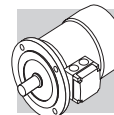

C_

M11.14 Protection de surface

Lorsque qu'aucune classe de protection n'est requise, les surfaces (ferreuses) des moteurs fournissent une protection minimale de classe C2 (UNI EN ISO 12944-2). Afin d'améliorer la résistance à la corrosion atmosphérique, les moteurs peuvent être fournis avec une protection de surface C3 et C4.

PROTECTION DE SURFACE	Environnements typiques	Température maximum de surface	Classe de corrosivité en accord avec UNI EN ISO 12944-2
C3	Environnement urbains et industriels avec jusqu'à 100% d'humidité relative (pollution de l'air moyenne)	120°C	C3
C4	Zones industrielles, zones côtières, usines chimiques, avec jusqu'à 100% d'humidité relative (pollution de l'air élevée)	120°C	C4

Les moteurs avec une protection optionnelle en classes C3 ou C4 sont disponibles dans plusieurs teintes.

Si aucune teinte spécifique n'est requise (voir l'option "PEINTURE"), les moteurs seront réalisés en RAL 7042.

Les moteurs peuvent également être fournis avec une protection de surface pour une corrosivité en classe C5 en accord avec UNI EN ISO 12944-2. Contacter notre Service Technique pour plus de détails.

RAL_

M11.15 Peinture

Les réducteurs avec une protection optionnelle en classe C3 ou C4 sont disponibles dans les teintes indiquées dans la table suivante.

PEINTURE	Couleur	RAL numéro
RAL7042*	Gris trafic A	7042
RAL5010	Bleu gentiane	5010
RAL9005	Noir foncé	9005
RAL9006	Aluminium blanc	9006
RAL9010	Blanc pur	9010

* Les réducteurs sont fournis dans cette teinte standard si rien n'est spécifié.

NOTE – Les options "PEINTURE" peuvent seulement être spécifiées en accord avec les options "PROTECTION DE SURFACE".

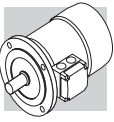

M11.16 Preuves documentaires

ACM

Certificat de conformité des moteurs

Document dont la délivrance atteste de la conformité du produit à la commande et de la construction de celui-ci conformément aux procédures standard de traitement et de contrôle prévues par le système de Qualité Bonfiglioli Riduttori.

CC

Certificat de réception

La spécification implique la réalisation de vérifications de conformité à la commande, des contrôles visuels généraux et des vérifications instrumentales des caractéristiques électriques en fonctionnement à vide. La vérification s'applique à un échantillon statistique du lot d'expédition.

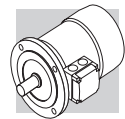

6P		1000 min ⁻¹ - S1																				50 Hz																			
		frein c.c.										frein c.c. à entrefer fixe										frein c.a.																			
		FD					AFD					FA					BA																								
P _n		n	M _n	IE1	η (100%)	η (75%)	η (50%)	cosφ	In	$\frac{I_s}{I_n}$	$\frac{M_s}{M_n}$	$\frac{M_a}{M_n}$	$\frac{J_m}{x 10^{-4}}$	IM B5	Mod	Mb	Z ₀	NB	1/h	J _m	IM B5	Mod	Mb	Z ₀	1/h	J _m	IM B5	Mod	Mb	Z ₀	1/h	J _m	IM B5								
0.09	BN 63A	6	880	0.98	○	41.0	32.9	0.53	0.60	2.1	2.1	1.8	3.4	4.6	FD 02	3.5	9000	14000	4.0	6.3	AFD 02	3.5	14000	4.0	6.1	FA 02	3.5	14000	4.0	6.1	BA 60	5.0	12000	5.4	6.9						
0.12	BN 63B	6	870	1.32	○	45.0	41.8	0.60	0.64	2.1	1.9	1.7	3.7	4.9	FD 02	3.5	9000	14000	4.3	6.6	AFD 02	3.5	14000	4.3	6.4	FA 02	3.5	14000	4.3	6.4	BA 60	5.0	12000	5.7	7.2						
0.18	BN 71A	6	900	1.91	○	55.0	51.0	0.69	0.68	2.6	1.9	1.7	8.4	5.5	FD 03	5	8100	13500	9.5	8.2	AFD 03	5	13500	9.5	7.9	FA 03	5.0	13500	9.5	7.9	BA 70	8.0	12300	10.4	9.4						
0.25	BN 71B	6	900	2.70	○	62.0	58.5	0.71	0.82	2.6	1.9	1.7	10.9	6.7	FD 03	5	7800	13000	12	9.4	AFD 03	5	13000	12	9.1	FA 03	5.0	13000	12	9.1	BA 70	8.0	12000	12.9	10.6						
0.37	BN 71C	6	910	3.9	○	66.0	60.0	0.69	1.17	3.0	2.4	2.0	12.9	7.7	FD 53	7.5	5100	9500	14	10.4	AFD 03	7.5	9500	14	10.1	FA 03	7.5	9500	14	10.1	BA 70	8.0	8900	14.9	11.6						
0.37	BN 80A	6	910	3.9	○	68.0	67.4	0.68	1.15	3.2	2.2	2.0	21	9.9	FD 04	10	5200	8500	23	13.8	AFD 04	10	8500	23	13.4	FA 04	10	8500	23	13.7	BA 80	18	8000	24	15.2						
0.55	BN 80B	6	920	5.7	○	70.0	69.8	0.68	1.67	3.9	2.6	2.2	25	11.3	FD 04	15	4800	7200	27	15.2	AFD 04	15	7200	27	14.8	FA 04	15	7200	27	15.1	BA 80	18	6800	28	16.6						
0.75	BN 80C	6	920	7.8	●	70.0	70.0	0.65	2.38	3.8	2.5	2.2	28	12.2	FD 04	15	3400	6400	30	16.1	AFD 04	15	6400	30	15.7	FA 04	15	6400	30	16.0	BA 80	18	6100	31	17.5						
0.75	BN 90S	6	920	7.8	●	70.0	69.0	0.68	2.27	3.8	2.4	2.2	26	12.6	FD 14	15	3400	6500	28	16.8	AFD 14	15	6500	28	16.4	FA 14	15	6500	28	16.7	BA 90	35	5500	33	19.9						
1.1	BN 90L	6	920	11.4	●	72.9	72.6	0.69	3.2	3.9	2.3	2.0	33	15	FD 05	26	2700	5000	37	21	AFD 05	26	5000	37	20	FA 05	26	5000	37	22	BA 90	35	4600	40	22						
1.5	BN 100LA	6	940	15.2	●	75.2	74.2	0.72	4.0	4.1	2.1	2.0	82	22	FD 15	40	1900	4100	86	28	AFD 15	40	4100	86	27	FA 15	40	4100	86	29	BA 100	50	3800	94	32						
1.85	BN 100LB	6	930	19.0	●	76.6	72.8	0.73	4.8	4.6	2.1	2.0	95	24	FD 15	40	1700	3600	99	30	AFD 15	40	3600	99	29	FA 15	40	3600	99	31	BA 100	50	3400	107	34						
2.2	BN 112M	6	940	22	●	78.5	79.0	0.73	5.5	4.8	2.2	2.0	168	32	FD 06S	60	—	2100	177	42	AFD 06S	60	2100	177	41	FA 06S	60	2100	177	44	BA 110	75	2000	184	45						
3	BN 132S	6	940	30	●	79.7	77.0	0.76	7.1	5.1	1.9	1.8	216	36	FD 56	75	—	1400	226	49	AFD 06	75	1400	226	48	FA 06	75	1400	226	50	BA 140	150	1200	266	68						
4	BN 132MA	6	950	40	●	81.4	81.5	0.77	9.2	5.5	2.0	1.8	295	45	FD 06	100	—	1200	305	58	AFD 06	100	1200	305	57	FA 07	100	1200	318	63	BA 140	150	1050	345	77						
5.5	BN 132MB	6	945	56	●	83.1	80.9	0.78	12.2	6.1	2.1	1.9	383	56	FD 07	150	—	1050	406	72	AFD 07	150	1050	406	70	FA 07	150	1050	406	74	BA 140	150	1000	433	88						
7.5	BN 160M	6	955	75	●	85.0	85.0	0.81	15.7	5.9	2.2	2.0	740	83	FD 08	170	—	900	815	112						FA 08	170	900	815	113											
11	BN 160L	6	960	109	●	86.4	86.5	0.81	22.7	6.6	2.5	2.3	970	103	FD 08	200	—	800	1045	133						FA 08	200	800	1045	133											
15	BN 180L	6	970	148	●	87.7	88.0	0.82	30	6.2	2.0	2.4	1550	130	FD 09	300	—	600	1750	170																					
18.5	BN 200LA	6	960	184	●	88.6	88.0	0.81	37	5.9	2.0	2.3	1700	145	FD 09	400	—	450	1900	185																					

○ = n.a. ● = IE1

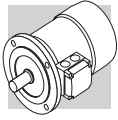

2/4P

3000/1500 min⁻¹ - S1

50 Hz

P _n kW	Image	n min ⁻¹	M _h Nm	η %	cosφ	I _n 400V A	I _s I _n	M _s M _n	M _a M _n	J _m x 10 ⁻⁴ kgm ²	IM B5 Kg	frein c.c.						frein c.c. à entrefer fixe						frein c.a.											
												FD			AFD			FA			BA			FD			AFD			FA			BA		
												Mod	Mb Nm	Z _o 1/h	J _m x 10 ⁻⁴ kgm ²	IM B5 Kg	Mod	Mb Nm	Z _o 1/h	J _m x 10 ⁻⁴ kgm ²	IM B5 Kg	Mod	Mb Nm	Z _o 1/h	J _m x 10 ⁻⁴ kgm ²	IM B5 Kg	Mod	Mb max. Nm	Z _o 1/h	J _m x 10 ⁻⁴ kgm ²	IM B5 Kg	Mod	Mb max. Nm	Z _o 1/h	J _m x 10 ⁻⁴ kgm ²
0.20	BN 63B	2	2700	0.71	55	0.82	0.64	1.9	2.9	4.4	6.1	AFD 02	3.5	2600	5100	5.9	FA 02	3.5	2600	5100	5.9	BA 60	5.0	2000	4000	4.9	6.7								
0.15	4	1350	1.06	49	0.67	0.66	2.6	1.8	1.7																										
0.28	BN 71A	2	2700	0.99	56	0.82	0.88	1.9	1.7	4.4	7.1	FD 03	3.5	2100	2400	5.8	AFD 03	5	2400	4800	6.8	BA 70	8.0	2100	5.6	8.3									
0.20	4	1370	1.39	59	0.72	0.68	3.1	1.8	1.7	3.80	4.800																								
0.37	BN 71B	2	2740	1.29	56	0.82	1.16	1.8	1.8	5.1	7.8	FD 03	5.0	1400	2100	6.9	AFD 03	5	2100	4200	7.5	BA 70	8.0	1800	7.8	9.0									
0.25	4	1390	1.72	60	0.73	0.82	3.3	2.0	1.9	2.90	4.200																								
0.45	BN 71C	2	2780	1.55	63	0.85	1.21	1.8	1.8	5.9	8.6	FD 03	5.0	1400	2100	8.0	AFD 03	5	2100	4200	8.3	BA 70	8.0	1800	8.9	9.8									
0.30	4	1400	2.0	63	0.73	0.94	3.6	2.0	1.9	2.90	4.200																								
0.55	BN 80A	2	2800	1.9	63	0.85	1.48	1.7	1.7	8.2	12.1	FD 04	5.0	1600	2300	17	AFD 04	5	2300	4000	11.7	BA 80	18	2100	18	13.5									
0.37	4	1400	2.5	67	0.79	1.01	4.1	1.8	1.9	3.00	4.000																								
0.75	BN 80B	2	2780	2.6	65	0.85	1.96	1.8	1.8	9.9	13.8	FD 04	10	1400	1600	22	AFD 04	10	1600	3600	13.4	BA 80	18	1500	22	15.2									
0.55	4	1400	3.8	68	0.81	1.44	3.9	1.7	1.7	2.70	3.600																								
1.1	BN 90S	2	2790	3.8	71	0.82	2.73	2.0	2.0	12.2	16.4	FD 14	10	1500	1600	23	AFD 14	10	1600	23	16	BA 90	35	1300	28	19.5									
0.75	4	1390	5.2	66	0.79	2.08	4.6	2.4	2.2	2.300	2.800																								
1.5	BN 90L	2	2780	5.2	70	0.85	3.64	2.4	2.1	14.0	20	FD 05	26	1050	1200	32	AFD 05	26	1200	32	19.4	BA 90	35	1100	35	21									
1.1	4	1390	7.6	73	0.81	2.69	4.7	2.5	2.2	1.600	2.000																								
2.2	BN 100LA	2	2800	7.5	72	0.85	5.2	2.0	1.9	18.3	25	FD 15	26	600	900	44	AFD 15	26	900	44	24.4	BA 100	50	750	51	29									
1.5	4	1410	10.2	73	0.79	3.8	4.7	2.0	2.0	1300	2300																								
3.5	BN 100LB	2	2850	11.7	80	0.84	7.5	2.4	2.1	25	31	FD 15	40	500	900	65	AFD 15	40	900	65	30	BA 100	50	750	72	35									
2.5	4	1420	16.8	82	0.80	5.5	5.2	2.2	2.2																										
4	BN 112M	2	2880	13.3	79	0.83	8.8	2.4	2.0	30	40	FD 06S	60																						
3.3	4	1420	22.2	80	0.80	7.4	5.1	2.1	2.0																										
5.5	BN 132S	2	2890	18.2	80	0.87	11.4	2.4	2.0	44	57	FD 56	75																						
4.4	4	1440	29	82	0.84	9.2	5.3	2.2	2.0																										
7.5	BN 132MA	2	2900	25	82	0.87	15.2	2.4	2.0	53	66	FD 06	100																						
6	4	1430	40	84	0.85	12.1	5.8	2.3	2.1																										
9.2	BN 132MB	2	2920	30	83	0.86	18.6	2.6	2.2	59	75	FD 07	150																						
7.3	4	1440	48	85	0.85	14.6	5.5	2.3	2.1																										

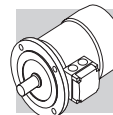

2/6P **3000/1000 min-1 - S3 60/40%** **50 Hz**

		frein c.c.											frein c.c. à entrefer fixe											frein c.a.										
		FD						AFD					FA					BA																
P_n		n	M_n	η	$\cos\phi$	I_n	$\frac{I_s}{I_n}$	$\frac{M_s}{M_n}$	$\frac{M_a}{M_n}$	J_m	IM B5	Mod	Mb	Z_o	J_m	IM B5	Mod	Mb	Z_o	J_m	IM B5	Mod	Mb	Z_o	J_m	IM B5	Mod	Mb	Z_o	J_m	IM B5			
kW		min-1	Nm	%		400V	A			$\times 10^{-4}$	$\frac{Kg}{Kg}$		Nm	1/h	$\times 10^{-4}$	$\frac{Kg}{Kg}$		Nm	1/h	$\times 10^{-4}$	$\frac{Kg}{Kg}$		Nm	1/h	$\times 10^{-4}$	$\frac{Kg}{Kg}$		Nm	1/h	$\times 10^{-4}$	$\frac{Kg}{Kg}$			
0.25	BN 71A	2	0.84	60	0.82	0.73	4.3	1.9	1.8	6.9	5.9	FD 03	1.75	1500	1700	8.0	8.6	AFD 03	2.5	1700	8.0	8.3	FA 03	2.5	1700	8.0	8.3	BA 70	8.0	1500	8.9	9.8		
0.08		6	0.84	43	0.70	0.38	2.1	1.4	1.5	10000	13000		10000	13000					13000					11000					11000					
0.37	BN 71B	2	1.23	62	0.80	1.08	4.4	1.9	1.8	9.1	7.3	FD 03	3.5	1000	1300	10.2	10.0	AFD 03	5	1300	10.2	9.7	FA 03	3.5	1300	10.2	9.7	BA 70	8.0	1200	11.1	11.2		
0.12		6	1.27	44	0.73	0.54	2.4	1.4	1.5	9000	11000		9000	11000					11000					11000					10000					
0.55	BN 80A	2	1.88	63	0.86	1.47	4.5	1.9	1.7	20	9.9	FD 04	5.0	1500	1800	22	13.8	AFD 04	5	1800	22	13.4	FA 04	5.0	1800	22	13.7	BA 80	18	1700	23	15.2		
0.18		6	1.85	52	0.65	0.77	3.3	2.0	1.9	4100	6300		4100	6300					6300					6300					6000					
0.75	BN 80B	2	2.6	66	0.87	1.89	4.3	1.8	1.6	25	11.3	FD 04	5.0	1700	1900	27	15.2	AFD 04	5	1900	27	14.8	FA 04	5.0	1900	27	15.1	BA 80	18	1800	28	16.6		
0.25		6	2.6	54	0.67	1.00	3.2	1.7	1.8	3800	6000		3800	6000					6000					6000					5600					
1.10	BN 90L	2	3.7	67	0.84	2.82	4.7	2.1	1.9	28	14.0	FD 05	13	1400	1600	32	20	AFD 05	13	1600	32	19.4	FA 05	13	1600	32	21	BA 90	35	1500	35	21		
0.37		6	3.8	59	0.71	1.27	3.3	1.6	1.6	3400	5200		3400	5200					5200					5200					4700					
1.5	BN 100LA	2	5	73	0.84	3.53	5.1	1.9	2.0	40	18.3	FD 15	13	1000	1200	44	24	AFD 15	13	1200	44	23.4	FA 15	13	1200	44	25	BA 100	50	1050	51	29		
0.55		6	5.6	64	0.67	1.85	3.5	1.7	1.8	2900	4000		2900	4000					4000					4000					3500					
2.2	BN 100LB	2	7.2	77	0.85	4.9	5.9	2.0	2.0	61	25	FD 15	26	700	900	65	31	AFD 15	26	900	65	30	FA 15	26	900	65	32	BA 100	50	800	72	36		
0.75		6	7.5	67	0.64	2.5	3.3	1.9	1.8	2100	3000		2100	3000					3000					3000					2700					
3	BN 112M	2	9.9	78	0.87	6.4	6.3	2.0	2.1	98	30	FD 06S	40	—	1000	107	40	AFD 06S	40	1000	107	39	FA 06S	40	1000	107	32	BA 110	75	930	114	43		
1.1		6	11.1	72	0.64	3.4	3.9	1.8	1.8	—	—		—	2600	—	—	—		2600	—	—	—		2600	—	—	—	2400	—	—	—	—		
4.5	BN 132S	2	14.8	78	0.84	9.9	5.8	1.9	1.8	213	44	FD 56	37	—	500	223	57	AFD 06	37	500	223	56	FA 06	37	500	223	58	BA 140	150	400	263	76		
1.5		6	14.9	74	0.67	4.4	4.2	1.9	2.0	—	—		—	2100	—	—	—		2100	—	—	—		2100	—	—	—	1700	—	—	—	—		
5.5	BN 132M	2	18.0	78	0.87	11.7	6.2	2.1	1.9	270	53	FD 56	50	—	400	280	66	AFD 06	62	400	280	65	FA 06	50	400	280	67	BA 140	150	350	320	85		
2.2		6	22	77	0.71	5.8	4.3	2.1	2.0	—	—		—	1900	—	—	—		1900	—	—	—		1900	—	—	—	1600	—	—	—	—		

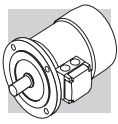

218P **3000/750 min⁻¹ - S3 60/40%** **50 Hz**



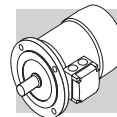

P _n kW		frein c.c.														frein c.c. à entrefer fixe										frein c.a.									
		FD							AFD							FA					BA														
		IM B5 Kg	J _m x 10 ⁻⁴ kgm ²	M _a M _n	M _s M _n	I _s I _n	I _n 400V A	cosφ	η	M _n Nm	n min ⁻¹	M _b Nm	Mod	Z ₀ 1/h	J _m x 10 ⁻⁴ kgm ²	IM B5 Kg	M _b Nm	Mod	Z ₀ 1/h	J _m x 10 ⁻⁴ kgm ²	IM B5 Kg	M _b max. Nm	Mod	Z ₀ 1/h	J _m x 10 ⁻⁴ kgm ²	IM B5 Kg	M _b Nm	Mod	Z ₀ 1/h	J _m x 10 ⁻⁴ kgm ²	IM B5 Kg				
0.25	BN 71A	2	2790	0.86	61	0.87	3.9	0.68	1.8	1.9	1.9	1300	1400	12	9.4	AFD 03	2.5	1400	12	9.1	FA 03	2.5	1400	12	9.1	FA 03	2.5	1400	12	9.1	BA 70	8.0	1300	12.9	10.6
0.06		8	680	0.84	31	0.61	2.0	0.46	1.8	1.9	10000	13000																							
0.37	BN 71B	2	2800	1.26	63	0.86	3.9	0.99	1.8	1.9	1200	1300	14	10.4	AFD 03	5	1300	14	10.1	FA 03	3.5	1300	14	10.1	FA 03	3.5	1300	14	10.1	BA 70	8.0	1200	14.9	11.6	
0.09		8	670	1.28	34	0.75	1.8	0.51	1.4	1.5	9500	13000																							
0.55	BN 80A	2	2830	1.86	66	0.86	4.4	1.40	2.1	2.0	1500	1800	22	13.8	AFD 04	5	1800	22	13.4	FA 04	5.0	1800	22	13.4	FA 04	5.0	1800	22	13.7	BA 80	18	1700	23	15.2	
0.13		8	690	1.80	41	0.64	2.3	0.72	1.6	1.7	5600	8000																							
0.75	BN 80B	2	2800	2.6	68	0.88	4.6	1.81	2.1	2.0	1700	1900	27	15.2	AFD 04	10	1900	27	14.8	FA 04	10	1900	27	14.8	FA 04	10	1900	27	15.1	BA 80	18	1800	28	16.6	
0.18		8	690	2.5	43	0.66	2.3	0.92	1.6	1.7	4800	7300																							
1.10	BN 90L	2	2830	3.7	63	0.84	3.00	3.00	2.1	1.9	1400	1600	32	20	AFD 05	13	1600	32	19.4	FA 05	13	1600	32	19.4	FA 05	13	1600	32	21	BA 90	35	1400	35	21	
0.28		8	690	3.9	48	0.63	2.4	1.34	1.8	1.9	3400	5100																							
1.5	BN 100LA	2	2880	5.0	69	0.85	4.7	3.69	1.9	1.8	1000	1200	44	25	AFD 15	13	1200	44	14.4	FA 15	13	1200	44	14.4	FA 15	13	1200	44	25	BA 100	50	1000	52	29	
0.37		8	690	5.1	46	0.63	2.1	1.84	1.6	1.6	3300	5000																							
2.4	BN 100LB	2	2900	7.9	75	0.82	5.6	5.6	2.1	2.0	550	700	65	31	AFD 15	26	700	65	30	FA 15	26	700	65	30	FA 15	26	700	65	32	BA 100	50	600	72	36	
0.55		8	700	7.5	54	0.58	2.6	1.8	1.8	1.8	2000	3500																							
3	BN 112M	2	2900	9.9	76	0.87	6.5	6.5	2.1	1.9	—	900	107	40	AFD 06S	40	900	107	39	FA 06S	40	900	107	39	FA 06S	40	900	107	42	BA 110	75	800	114	43	
0.75		8	690	10.4	60	0.65	2.8	2.5	1.6	1.6	—	2900																							
4	BN 132S	2	2870	13.3	73	0.84	9.4	9.4	2.3	2.4	500	223	57	AFD 06	37	500	223	56	FA 06	37	500	223	56	FA 06	37	500	223	58	BA 140	150	400	263	76		
1		8	690	13.8	66	0.62	3.5	2.9	1.9	1.8	—	3500																							
5.5	BN 132M	2	2870	18.3	75	0.84	12.6	12.6	2.4	2.5	400	280	66	AFD 06	62	400	280	65	FA 06	62	400	280	65	FA 06	62	400	280	67	BA 140	150	350	320	85		
1.5		8	690	21	68	0.63	5.1	2.9	1.9	1.9	—	2400																							



2/12P

3000/500 min⁻¹ - S3 60/40%

50 Hz

P _n kW		n min ⁻¹	M _n Nm	η %	cosφ	In 400V A	Is In	M _s M _n	M _a M _n	frein c.c.																																	
										FD						AFD						frein c.a.																					
										IM B5 	J _m x 10 ⁻⁴ kgm ²	Z ₀ 1/h	NB	SB	Mb Nm	Mod	IM B5 	J _m x 10 ⁻⁴ kgm ²	Z ₀ 1/h	SB	Mb Nm	Mod	IM B5 	J _m x 10 ⁻⁴ kgm ²	Z ₀ 1/h	Mb Nm	Mod	IM B5 	J _m x 10 ⁻⁴ kgm ²	Z ₀ 1/h	Mb max. Nm	IM B5											
0.55	BN 80B	2 12	2820 430	1.86 2.0	64 30	0.89 0.63	1.39 0.69	4.2 1.8	1.6 1.8	1.7 1.8	11.3	25	1300 8000	1000 12000	5	FD 04	15.2	27	1300 12000	14.8	27	1300 12000	5	AFD 04	15.2	27	1300 12000	18	BA 80	18	1200 11000	15.1	27	1300 12000	13	FA 04	15.1	27	1300 12000	18	BA 80		
0.75	BN 90L	2 12	2790 430	2.6 2.7	56 26	0.89 0.63	2.17 1.06	4.2 1.7	1.8 1.4	1.7 1.6	12.6	26	1000 4600	1150 6300	13	FD 05	18.6	30	1150 6300	18.0	30	1150 6300	13	AFD 05	18.0	30	1150 6300	35	BA 90	35	1050 5700	19.3	30	1150 6300	13	FA 05	19.3	30	1150 6300	35	BA 90		
1.10	BN 100LA	2 12	2850 430	3.7 4.0	65 26	0.85 0.54	2.87 1.85	4.5 1.5	1.6 1.3	1.8 1.5	18.3	40	700 4000	900 6000	13	FD 15	25	44	900 6000	24.4	44	900 6000	13	AFD 15	24.4	44	900 6000	50	BA 100	50	750 5000	25	BA 100	25	44	900 6000	13	FA 15	25	44	900 6000	50	BA 100
1.5	BN 100LB	2 12	2900 440	4.9 5.4	67 36	0.86 0.46	3.76 2.18	5.6 1.8	1.9 1.7	1.9 1.8	22	54	700 3800	900 5000	13	FD 15	28	58	900 5000	27	58	900 5000	13	AFD 15	27	58	900 5000	50	BA 100	50	800 4300	29	BA 100	29	58	900 5000	13	FA 15	29	58	900 5000	50	BA 100
2	BN 112M	2 12	2900 460	6.6 6.2	74 46	0.88 0.43	4.43 2.19	6.5 2.0	2.1 2.0	2.0 2.0	30	98	— —	800 3400	20	FD 06S	40	107	800 3400	39	107	800 3400	20	AFD 06S	39	107	800 3400	75	BA 110	75	750 3200	42	BA 110	42	107	800 3400	20	FA 06S	42	107	800 3400	75	BA 110
3	BN 132S	2 12	2920 470	9.8 10.2	74 51	0.87 0.43	6.7 3.3	6.8 2.0	2.3 1.7	1.9 1.6	44	213	— —	450 3000	37	FD 56	57	223	450 3000	56	223	450 3000	37	AFD 06	56	223	450 3000	150	BA 140	150	380 2500	58	BA 140	58	223	450 3000	37	FA 06	58	223	450 3000	150	BA 140
0.5	BN 132M	2 12	2920 460	13.1 14.5	75 53	0.89 0.44	8.6 4.3	5.9 1.9	2.4 1.7	2.3 1.6	53	270	— —	400 2800	37	FD 56	66	280	400 2800	65	280	400 2800	37	AFD 06	65	280	400 2800	150	BA 140	150	350 2500	67	BA 140	67	280	400 2800	37	FA 06	67	280	400 2800	150	BA 140
0.7	BN 132M	2 12	2920 460	13.1 14.5	75 53	0.89 0.44	8.6 4.3	5.9 1.9	2.4 1.7	2.3 1.6	53	270	— —	400 2800	37	FD 56	66	280	400 2800	65	280	400 2800	37	AFD 06	65	280	400 2800	150	BA 140	150	350 2500	67	BA 140	67	280	400 2800	37	FA 06	67	280	400 2800	150	BA 140

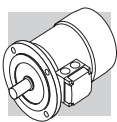

4/6P **1500/1000 min⁻¹ - S1** **50 Hz**



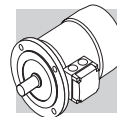

P _n kW	n min ⁻¹	M _n Nm	η	cosφ	In 400V A	I _s I _n	M _s M _n	M _a M _n	J _m x 10 ⁻⁴ kgm ²	IM B5 Kg	frein c.c.										frein c.c. à entrefer fixe										frein c.a.												
											FD					AFD					FA					BA																	
											Mod	Mb Nm	Z ₀ 1/h	J _m x 10 ⁻⁴ kgm ²	IM B5 Kg	Mod	Mb Nm	Z ₀ 1/h	J _m x 10 ⁻⁴ kgm ²	IM B5 Kg	Mod	Mb Nm	Z ₀ 1/h	J _m x 10 ⁻⁴ kgm ²	IM B5 Kg	Mod	Mb max. Nm	Z ₀ 1/h	J _m x 10 ⁻⁴ kgm ²	IM B5 Kg													
0.22	1410	1.5	64	0.74	0.67	3.9	1.8	1.9	9.1	7.3	FD 03	3.5	2500	3500	10.2	10.0	AFD 03	5	3500	9000	10.2	9.7	FA 03	3.5	3500	9000	10.2	9.7	BA 70	8.0	3200	8200	11.1	11.2									
0.13	920	1.4	43	0.67	0.65	2.3	1.6	1.7																																			
0.30	1410	2.0	61	0.82	0.87	3.5	1.3	1.5	15	8.2	FD 04	5.0	2500	3100	16.6	12.1	AFD 04	5	3100	6000	16.6	11.7	FA 04	5.0	3100	6000	16.6	12.0	BA 80	18	2800	5500	18	13.5									
0.20	930	2.1	54	0.66	0.81	3.2	1.9	2.0																																			
0.40	1430	2.7	63	0.75	1.22	3.9	1.8	1.8	20	9.9	FD 04	10	1800	2300	22	13.8	AFD 04	10	2300	5500	22	13.4	FA 04	10	2300	5500	22	13.7	BA 80	18	2200	5200	23	15.2									
0.26	930	2.7	55	0.70	0.97	2.7	1.5	1.6																																			
0.55	1420	3.7	70	0.78	1.45	4.5	2.0	1.9	21	12.2	FD 14	10	1500	2100	23	16.1	AFD 14	10	2100	4100	23	15.7	FA 14	10	2100	4100	23	16.3	BA 90	35	1700	28	19.5										
0.33	930	3.4	62	0.70	1.10	3.7	2.3	2.0																																			
0.75	1420	5.0	74	0.78	1.88	4.3	1.9	1.8	28	14	FD 05	13	1400	2000	32	20	AFD 05	13	2000	3600	32	19.4	FA 05	13	2000	3600	32	21	BA 90	35	1800	35	21										
0.45	920	4.7	66	0.71	1.39	3.3	2.0	1.9																																			
1.1	1450	7.2	74	0.79	2.72	5.0	1.7	1.9	82	22	FD 15	26	1400	2000	86	28	AFD 15	26	2000	86	27		FA 15	26	2000	86	29	BA 100	50	1800	94	32											
0.8	950	8.0	65	0.69	2.57	4.1	1.9	2.1																																			
1.5	1450	9.9	75	0.79	3.65	5.1	1.7	1.9	95	25	FD 15	26	1300	1800	99	31	AFD 15	26	1800	99	30		FA 15	26	1800	99	32	BA 100	50	1600	107	34											
1.1	950	11.1	72	0.68	3.24	4.3	2.0	2.1																																			
2.3	1450	15.2	75	0.78	5.7	5.2	1.8	1.9	168	32	FD 06S	40	—	1600	177	42	AFD 06S	40	1600	177	41		FA 06S	40	1600	177	44	BA 110	75	1500	184	45											
1.5	960	14.9	73	0.72	4.1	4.9	2.0	2.0																																			
3.1	1460	20	83	0.83	6.5	5.9	2.1	2.0	213	44	FD 56	37	—	1200	223	57	AFD 06	62	1200	223	56		FA 06	37	1200	223	58	BA 140	150	1000	263	76											
2	960	20	77	0.75	4.9	4.5	2.1	2.1																																			
4.2	1460	27	84	0.82	8.8	5.9	2.1	2.2	270	53	FD 06	50	—	900	280	66	AFD 06	62	900	280	65		FA 06	50	900	280	67	BA 140	150	800	320	85											
2.6	960	26	79	0.72	6.6	4.3	2.0	2.0																																			



4/8P

1500/750 min⁻¹ - S1

50 Hz

P _n kW		n min ⁻¹	M _n Nm	η %	cosφ	I _n 400V A	I _s I _n	M _s M _n	M _a M _n	frein c.c.										frein c.c. à entrefer fixe										frein c.a.									
										FD					AFD					FA					BA														
										IM B5 	J _m x 10 ⁻⁴ kgm ²	Z ₀ 1/h SB	Mb Nm	Mod	IM B5 	J _m x 10 ⁻⁴ kgm ²	Z ₀ 1/h SB	Mb Nm	Mod	IM B5 	J _m x 10 ⁻⁴ kgm ²	Z ₀ 1/h kgm ²	Mb Nm	Mod	IM B5 	J _m x 10 ⁻⁴ kgm ²	Z ₀ 1/h	Mb max. Nm	Mod										
0.37	BN 80A	4	1400	2.5	63	0.82	1.03	3.3	1.4	1.4	8.2	15	2300	3500	16.6	12.1	17.4	10	3500	7000	16.6	12.0	BA 80	18	3200	18	13.5												
0.18		8	690	2.5	44	0.60	0.98	2.2	1.5	1.6			4500	7000										6500															
0.55	BN 80B	4	1390	3.8	65	0.86	1.42	3.8	1.7	1.6	9.9	20	2200	2900	22	13.8	13.4	10	2900	6500	22	13.7	BA 80	18	2500	23	15.2												
0.30		8	670	4.3	49	0.65	1.36	2.3	1.7	1.8			4200	6500										5600															
0.65	BN 90S	4	1390	4.5	73	0.85	1.51	4.0	1.9	1.9	13.6	28	2300	2800	30	17.8	17.4	15	2800	6000	30	17.7	BA 90	35	2400	35	21												
0.35		8	690	4.8	49	0.57	1.81	2.5	2.1	2.2			3500	6000										5100															
0.9	BN 90L	4	1370	6.3	73	0.87	2.05	3.8	1.8	1.8	15.1	30	1700	2100	34	21	20.4	26	2100	4200	34	22	BA 90	35	1900	37	22												
0.5		8	670	7.1	57	0.62	2.04	2.4	2.1	2.0			2500	4200										3800															
1.30	BN 100LA	4	1420	8.7	72	0.83	3.14	4.3	1.7	1.8	22	82	1300	1700	86	28	27	40	1700	3400	86	29	BA 100	50	1500	94	32												
0.70		8	700	9.6	58	0.64	2.72	2.8	1.8	1.8			2000	3400										3100															
1.8	BN 100LB	4	1420	12.1	69	0.87	4.3	4.2	1.6	1.7	25	95	1200	1700	99	31	30	40	1700	2600	99	32	BA 100	50	1500	107	34												
0.9		8	700	12.3	62	0.63	3.3	3.2	1.7	1.8			1600	2600										2400															
2.2	BN 112M	4	1440	14.6	77	0.85	4.9	5.3	1.8	1.8	32	168	—	1200	177	42	41	60	1200	2000	177	43	BA 110	75	1100	184	45												
1.2		8	710	16.1	70	0.63	3.9	3.3	1.9	1.8			—	2000										1900															
3.6	BN 132S	4	1440	24	80	0.82	7.9	6.5	2.1	1.9	45	295	—	1000	305	58	57	75	1000	305	305	59	BA 140	150	900	345	77												
1.8		8	720	24	72	0.55	6.6	4.6	1.9	2.0			—	1400										1200															
4.6	BN 132M	4	1450	30	81	0.83	9.9	6.5	2.2	1.9	56	383	—	1000	393	69	68	100	1000	393	406	74	BA 140	150	900	433	88												
2.3		8	720	31	73	0.54	8.4	4.4	2.3	2.0			—	1300										1200															

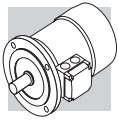

2P **3000 min⁻¹ - S1** **50 Hz**

P _n kW	n min ⁻¹	M _n Nm	IE1	η (100%) %	η (75%) %	η (50%) %	cosφ	In 400V A	Is In %	Ms Mn %	Ma Mn %	frein c.c.										frein c.c. à entrefer fixe						frein c.a.					
												FD					AFD					FA											
												Mod	Mb Nm	Z ₀ 1/h	J _m x 10 ⁻⁴ kgm ²	IM B5 Kg	Mod	Mb Nm	Z ₀ 1/h	J _m x 10 ⁻⁴ kgm ²	IM B5 Kg	Mod	Mb Nm	Z ₀ 1/h	J _m x 10 ⁻⁴ kgm ²	IM B5 Kg	Mod	Mb Nm	Z ₀ 1/h	J _m x 10 ⁻⁴ kgm ²	IM B5 Kg		
0.18	M 05A 2	2730	0.63	○	59.9	64.8	51.9	0.77	0.56	3.0	2.1	2.0	2.0	3.2	FD 02	1.75	3900	4800	2.6	4.9	FD 02	1.75	3900	4800	2.6	4.7	FA 02	1.75	4800	2.6	4.7		
0.25	M 05B 2	2740	0.87	○	66.0	64.8	64.8	0.76	0.72	3.3	2.3	2.3	2.3	3.6	FD 02	1.75	3900	4800	3.0	5.3	AFD 02	1.75	3900	4800	3.0	5.1	FA 02	1.75	4800	3.0	5.1		
0.37	M 05C 2	2800	1.26	○	69.1	66.8	66.8	0.78	0.99	3.9	2.6	2.6	3.3	4.8	FD 02	3.5	3600	4500	3.9	6.5	AFD 02	3.5	3600	4500	3.9	6.3	FA 02	3.5	4500	3.9	6.3		
0.55	M 15D 2	2820	1.86	○	76.0	75.8	74.8	0.76	1.37	5.0	2.9	2.8	4.1	5.8	FD 03	5	2900	4200	5.3	8.5	AFD 03	5	2900	4200	5.3	8.2	FA 03	5	4200	5.3	8.2		
0.75	M 15A 2	2810	2.6	○	76.6	76.2	76.2	0.76	1.86	5.1	3.1	2.8	5.0	6.9	FD 03	5	1900	3300	6.1	9.6	AFD 03	7.5	3300	3300	6.1	9.3	FA 03	5	3300	6.1	9.3		
1.1	M 25A 2	2800	3.8	●	76.4	76.2	75.0	0.81	2.57	4.8	2.8	2.4	9.0	8.8	FD 04	10	1500	3000	10.6	11.9	AFD 04	10	1500	3000	10.6	11.5	FA 04	10	3000	10.6	12.6		
1.5	M 25B 2	2800	5.1	●	79.1	79.5	77.2	0.81	3.4	4.9	2.7	2.4	11.4	10.6	FD 04	15	1300	2600	13.0	9.9	AFD 04	15	1300	2600	13.0	9.5	FA 04	15	2600	13.0	14.4		
2.2	M 35A 2	2880	7.3	●	82.7	82.1	81.0	0.80	4.8	6.3	2.9	2.7	24	15.5	FD 15	26	1100	2400	28	22	AFD 15	26	1100	2400	28	21.4	FA 15	26	2400	28	23		
3	M 35A 2	2860	10.0	●	81.5	81.3	77.4	0.79	6.7	5.6	2.6	2.2	31	18.7	FD 15	26	700	1600	35	25	AFD 15	26	700	1600	35	24.4	FA 15	26	1600	35	26		
4	M 35B 2	2870	13.3	●	83.1	83.0	77.8	0.80	8.7	5.8	2.7	2.5	39	22	FD 15	40	450	900	43	28	AFD 15	40	450	900	43	27	FA 15	40	900	43	29		
5.5	M 45A 2	2890	18.2	●	84.7	84.5	81.2	0.84	11.2	5.9	2.6	2.2	101	33	FD 06	50	—	600	112	46	46	AFD 06	62	600	600	112	45	FA 06	50	600	112	47	
7.5	M 45B 2	2900	25	●	86.5	86.3	84.4	0.85	14.7	6.4	2.6	2.2	145	40	FD 06	50	—	550	154	53	53	AFD 06	62	550	550	154	52	FA 06	50	550	154	54	
9.2	M 45A 2	2930	30	●	87.0	86.5	83.6	0.86	17.7	6.7	2.8	2.3	178	51	FD 56	75	—	430	189	64	64	AFD 06	75	430	430	189	63	FA 06	75	430	189	65	
11	M 45C 2	2920	36	●	87.6	87.0	86.0	0.88	20.6	6.9	2.9	2.5	210	60																			
15	M 55B 2	2930	49	●	89.6	89.4	88.0	0.86	28.1	7.1	2.6	2.3	340	70																			
18.5	M 55C 2	2930	60	●	90.4	90.1	89.0	0.86	34	7.6	2.7	2.3	420	83																			
22	M 55A 2	2930	72	●	89.9	89.7	89.5	0.88	40	7.8	2.6	2.4	490	95																			

○ = n.a. ● = IE1

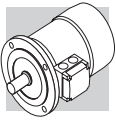

6P **1000 min⁻¹ - S1** **50 Hz**

P _n kW	n min ⁻¹	M _n Nm	IE1	η (100%) %	η (75%) %	η (50%) %	cosφ	In 400V A	Is In	Ms Mn	Ma Mn	J _m x 10 ⁻⁴ kgm ²	IM B5 Kg	frein c.c.						frein c.c. à entrefer fixe						frein c.a.						
														FD						AFD						FA						
														Mod	Mb Nm	Z ₀ 1/h	J _m x 10 ⁻⁴ kgm ²	IM B5 Kg	Mod	Mb Nm	Z ₀ 1/h	J _m x 10 ⁻⁴ kgm ²	IM B5 Kg	Mod	Mb Nm	Z ₀ 1/h	J _m x 10 ⁻⁴ kgm ²	IM B5 Kg	Mod	Mb Nm	Z ₀ 1/h	J _m x 10 ⁻⁴ kgm ²
0.09	M 05A 6	0.98	○	41.0	41.0	32.9	0.53	0.60	2.1	2.1	1.8	3.4	4.3	FD 02	3.5	9000	14000	4.0	6.0	AFD 02	3.5	14000	14000	4.0	5.8	FA 02	3.5	14000	14000	4.0	5.8	
0.12	M 05B 6	1.32	○	45.0	44.0	41.8	0.60	0.64	2.1	1.9	1.7	3.7	4.6	FD 02	3.5	9000	14000	4.3	6.3	AFD 02	3.5	14000	14000	4.3	6.1	FA 02	3.5	14000	14000	4.3	6.1	
0.18	M 15C 6	1.91	○	55.0	55.5	51.0	0.69	0.68	2.6	1.9	1.7	8.4	5.1	FD 03	5	8100	13500	9.5	7.8	AFD 03	5	13500	13500	9.5	7.5	FA 03	5	13500	13500	9.5	7.5	
0.25	M 15D 6	2.7	○	62.0	58.5	51.4	0.71	0.82	2.6	1.9	1.7	10.9	6.3	FD 03	5	7800	13000	12	9.0	AFD 03	5	13000	13000	12	8.7	FA 03	5	13000	13000	12	8.7	
0.37	M 15LA 6	3.9	○	66.0	60.0	53.3	0.69	1.17	3.0	2.4	2.0	12.9	7.3	FD 53	7.5	5100	9500	14	10.0	AFD 03	7.5	9500	9500	14	9.7	FA 03	7.5	9500	9500	14	9.7	
0.55	M 25A 6	5.7	○	70.0	69.8	64.3	0.68	1.67	3.9	2.6	2.2	25	10.6	FD 04	15	4800	7200	27	14.5	AFD 04	15	7200	7200	27	14.1	FA 04	15	7200	7200	27	14.4	
0.75	M 25B 6	7.8	●	70.0	70.0	64.4	0.65	2.38	3.8	2.5	2.2	28	11.5	FD 04	15	3400	6400	30	15.4	AFD 04	15	6400	6400	30	15	FA 04	15	6400	6400	30	15.3	
1.1	M 35A 6	11.4	●	75.0	74.0	72.0	0.72	2.9	4.3	2.0	1.8	33	17	FD 15	26	2700	5000	37	23	AFD 15	26	5000	5000	37	22.4	FA 15	26	5000	5000	37	24	
1.5	M 35LA 6	15.2	●	75.2	74.2	70.3	0.72	4.0	4.1	2.1	2.0	82	21	FD 15	40	1900	4100	86	27	AFD 15	40	4100	4100	86	26	FA 15	40	4100	4100	86	28	
1.85	M 35LB 6	19.0	●	76.6	72.8	62.6	0.73	4.8	4.6	2.1	2.0	95	23	FD 15	40	1700	3600	99	29	AFD 15	40	3600	3600	99	28	FA 15	40	3600	3600	99	30	
2.2	M 35LC 6	23	●	77.7	76.8	72.4	0.71	5.8	4.7	2.3	2.1	95	23	FD 55	55	—	1900	99	29	—	—	—	—	—	—	FA 15	55	1900	1900	99	30	
3	M 45A 6	30	●	79.7	77.0	75.1	0.76	7.1	5.1	1.9	1.8	216	34	FD 56	75	—	1400	226	47	47	AFD 06	75	1400	1400	226	46	FA 06	75	1400	1400	226	48
4	M 45LA 6	40	●	81.4	81.5	79.5	0.77	9.2	5.5	2.0	1.8	295	43	FD 06	100	—	1200	305	56	56	AFD 06	100	1200	1200	305	55	FA 07	100	1200	1200	305	57
5.5	M 45LB 6	56	●	83.1	80.9	79.1	0.78	12.2	6.1	2.1	1.9	383	54	FD 07	150	—	1050	406	70	70	AFD 07	150	1050	1050	406	68	FA 07	150	1050	1050	406	72
7.5	M 55A 6	75	●	85.0	85.0	84.8	0.81	15.7	5.9	2.2	2.0	740	69	FD 08	170	—	900	815	98	98	—	—	—	—	—	FA 08	170	900	900	800	98	
11	M 55B 6	109	●	86.4	86.5	85.9	0.81	22.7	6.6	2.5	2.3	970	89	FD 08	200	—	800	1045	119	119	—	—	—	—	—	FA 08	200	800	800	1030	118	

○ = n.a. ● = IE1

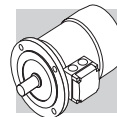

2/4P **3000/1500 min-1 - S1** **50 Hz**

P _n kW		frein c.c.														frein c.c. à entrefer fixe						frein c.a.					
		FD							AFD							FA											
		IM B5 Kg	J _m x 10 ⁻⁴ kgm ²	Z ₀ 1/h	NB	SB	Mb Nm	Mod	IM B5 Kg	J _m x 10 ⁻⁴ kgm ²	Z ₀ 1/h	SB	Mb Nm	Mod	IM B5 Kg	J _m x 10 ⁻⁴ kgm ²	Z ₀ 1/h	Mb Nm	Mod	IM B5 Kg	J _m x 10 ⁻⁴ kgm ²	Z ₀ 1/h	Mb Nm	Mod			
0.20	M 05A 2	4.1	2.9	2600	2200	3.5	FD 02	5.8	3.5	2600	4000	3.5	AFD 02	5.6	3.5	2600	5100	3.5	FA 02	5.6	3.5	2600	5100	3.5	FA 02		
0.15	4		1.7	0.66	0.66	1.8																					
0.28	M 15B 2	4.0	4.7	2400	2100	3.5	FD 03	6.7	5.8	2400	3800	5.8	AFD 03	6.4	5.8	2400	4800	5.8	FA 03	6.4	5.8	2400	4800	5.8	FA 03		
0.20	4		1.7	1.02	1.02	1.8																					
0.37	M 15C 2	4.7	5.8	2100	1400	5	FD 03	7.4	6.9	2100	2900	6.9	AFD 03	7.1	6.9	2100	4200	6.9	FA 03	7.1	6.9	2100	4200	6.9	FA 03		
0.25	4		1.9	0.82	0.82	2.0																					
0.45	M 15D 2	5.5	6.9	1400	1400	5	FD 03	8.2	8.0	1400	2900	8.0	AFD 03	7.9	8.0	1400	4200	8.0	FA 03	7.9	8.0	1400	4200	8.0	FA 03		
0.30	4		1.9	0.93	0.93	2.1																					
0.55	M 11A 2	6.9	9.1	1600	1600	5	FD 03	9.6	10.2	1600	3300	10.2	AFD 03	9.3	10.2	1600	4600	10.2	FA 03	9.3	10.2	1600	4600	10.2	FA 03		
0.37	4		2.0	1.09	1.09	2.2																					
0.75	M 25A 2	9.2	20	1400	1400	10	FD 04	13.1	22	1400	2700	22	AFD 04	12.7	22	1400	3600	22	FA 04	12.7	22	1400	3600	22	FA 04		
0.55	4		1.7	1.44	1.44	1.7																					
1.1	M 25B 2	10.7	25	1200	1200	10	FD 04	14.5	27	1200	2300	27	AFD 04	14.1	27	1200	3100	27	FA 04	14.1	27	1200	3100	27	FA 04		
0.75	4		2.0	1.78	1.78	2.1																					
1.5	M 35A 2	15.5	34	700	700	26	FD 15	22	38	700	1000	38	AFD 15	21.4	38	700	1000	38	FA 15	21.4	38	700	1000	38	FA 15		
1.1	4		2.0	2.6	2.6	2.1																					
2.2	M 35A 2	17	40	600	600	26	FD 15	24	44	600	900	44	AFD 15	23.4	44	600	900	44	FA 15	23.4	44	600	900	44	FA 15		
1.5	4		2.0	3.8	3.8	2.0																					
3.5	M 35B 2	23	61	500	500	40	FD 15	29	65	500	900	65	AFD 15	28	65	500	900	65	FA 15	28	65	500	900	65	FA 15		
2.5	4		2.2	5.5	5.5	2.2																					
4.8	M 45A 2	42	213	400	400	50	FD 06	55	233	400	950	233	AFD 06	54	233	400	950	233	FA 06	54	233	400	950	233	FA 06		
3.8	4		2.1	8.1	8.1	2.1																					
5.5	M 45B 2	42	213	350	350	75	FD 06	55	223	350	900	223	AFD 06	54	223	350	900	223	FA 06	54	223	350	900	223	FA 06		
4.4	4		2.0	9.2	9.2	2.0																					
7.5	M 45A 2	51	270	350	350	100	FD 06	64	280	350	950	280	AFD 06	63	280	350	950	280	FA 06	63	280	350	950	280	FA 06		
6	4		2.1	12.1	12.1	2.3																					
9.2	M 45B 2	57	319	300	300	150	FD 07	73	342	300	800	342	AFD 07	71	342	300	800	342	FA 07	71	342	300	800	342	FA 07		
7.3	4		2.1	14.6	14.6	2.3																					

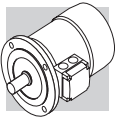



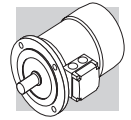

2/6P **3000/1000 min⁻¹ - S3 60/40%** **50 Hz**

		frein c.c.														frein c.c. à entrefer fixe						frein c.a.						
		FD							AFD							FA												
P _n		n	M _n	η	cosφ	I _n	I _s	$\frac{I_s}{I_n}$	$\frac{M_s}{M_n}$	$\frac{M_a}{M_n}$	J _m	IM B5	Mod	Mb	Z ₀	J _m	IM B5	Mod	Mb	Z ₀	J _m	IM B5	Mod	Mb	Z ₀	J _m	IM B5	
kW		min ⁻¹	Nm	%		A					kgm ²	Kg		Nm	SB	kgm ²	Kg		Nm	SB	kgm ²	Kg		Nm	SB	kgm ²	Kg	
0.25	M 1SA 2	2850	0.84	60	0.82	0.73	4.3	1.9	1.8	1.8	6.9	5.5	FD 03	1.75	1500	8.0	8.2	AFD 03	2.5	1700	8.0	7.9	FA 03	1.75	1700	8.0	7.9	
0.08	6	910	0.84	43	0.70	0.38	2.1	1.4	1.5	1.5	13000		10000	13000					5	13000				13000				
0.37	M 1LA 2	2880	1.23	62	0.80	1.08	4.4	1.9	1.8	1.8	9.1	6.9	FD 03	3.5	1000	10.2	9.6	AFD 03	5	1300	10.2	9.3	FA 03	3.5	1300	10.2	9.3	
0.12	6	900	1.27	44	0.73	0.54	2.4	1.4	1.5	1.5	11000		9000	11000					5	11000				11000				
0.55	M 2SA 2	2800	1.88	63	0.86	1.47	4.5	1.9	1.7	1.7	20	9.2	FD 04	5	1500	22	13.1	AFD 04	5	1800	22	12.7	FA 04	5	1800	22	13.0	
0.18	6	930	1.85	52	0.65	0.77	3.3	2.0	1.9	1.9	6300		4100	6300					5	6300				6300				
0.75	M 2SB 2	2800	2.6	66	0.87	1.89	4.3	1.8	1.6	1.6	25	10.6	FD 04	5	1700	27	14.5	AFD 04	5	1900	27	14.1	FA 04	5	1900	27	14.4	
0.25	6	930	2.6	54	0.67	1.00	3.2	1.7	1.8	1.8	3800		3800	6000					5	6000				6000				
1.1	M 3SA 2	2870	3.7	71	0.82	2.73	4.9	1.8	1.9	1.9	34	15.5	FD 15	13	1000	38	22	AFD 15	13	1300	38	21.4	FA 15	13	1300	38	23	
0.37	6	930	3.8	63	0.70	1.21	3.1	1.5	1.8	1.8	5000		3500	5000					13	5000				5000				
1.5	M 3LA 2	2880	5.0	73	0.84	3.53	5.1	1.9	2.0	2.0	40	17	FD 15	13	1000	44	24	AFD 15	13	1200	44	23.4	FA 15	13	1200	44	24	
0.55	6	940	5.6	64	0.67	1.85	3.5	1.7	1.8	1.8	2900		2900	4000					13	4000				4000				
2.2	M 3LB 2	2900	7.2	77	0.85	4.9	5.9	2.0	2.0	2.0	61	23	FD 15	26	700	65	29	AFD 15	26	900	65	28	FA 15	26	900	65	30	
0.75	6	950	7.5	67	0.64	2.5	3.3	1.9	1.8	1.8	2100		2100	3000					26	3000				3000				
3	M 4SA 2	2910	9.9	74	0.88	6.6	5.6	2.0	2.1	2.1	170	36	FD 56	37	—	182	48	AFD 06	37	600	182	47	FA 06	37	600	182	50	
1.1	6	960	10.9	73	0.68	3.2	4.5	2.2	2.0	2.0	2200		—	2200					37	2200				2200				
4.5	M 4SB 2	2910	14.8	78	0.84	9.9	5.8	1.9	1.8	1.8	213	42	FD 56	37	—	223	55	AFD 06	37	500	223	54	FA 06	37	500	223	56	
1.5	6	960	14.9	74	0.67	4.4	4.2	1.9	2.0	2.0	2100		—	2100					37	2100				2100				
5.5	M 4LA 2	2920	18.0	78	0.87	11.7	6.2	2.1	1.9	1.9	270	51	FD 06	50	—	280	64	AFD 06	62	400	280	63	FA 06	50	400	280	65	
2.2	6	960	22	77	0.71	5.8	4.3	2.1	2.0	2.0	1900		—	1900					62	1900				1900				





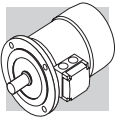

2/8P **3000/750 min⁻¹ - S3 60/40%** **50 Hz**

P _n kW		n min ⁻¹	M _n Nm	η %	cosφ	In 400V A	Is In	Ms Mn	Ma Mn	frein c.c.							frein c.c. à entrefer fixe							frein c.a.				
										FD				AFD			FA					AFD				FA		
										Mod	Mb Nm	Z _o 1/h	J _m x 10 ⁻⁴ kgm ²	IMB5 	Mod	Mb Nm	Z _o 1/h	J _m x 10 ⁻⁴ kgm ²	IMB5 	Mod	Mb Nm	Z _o 1/h	J _m x 10 ⁻⁴ kgm ²	IMB5 	Mod	Mb Nm	Z _o 1/h	J _m x 10 ⁻⁴ kgm ²
0.37	M 1LA 2	2800	1.26	63	0.86	0.99	3.9	1.8	1.9	12.9	7.3	FD 03	3.5	1200	1300	14	10.0	AFD 03	5	1300	14	9.7	FA 03	3.5	1300	14	9.7	
0.09	8	670	1.28	34	0.75	0.51	1.8	1.4	1.5	9500	13000																	
0.55	M 2SA 2	2830	1.86	66	0.86	1.40	4.4	2.1	2.0	20	9.2	FD 04	5	1500	1800	22	13.1	AFD 04	5	1800	22	12.7	FA 04	5	1800	22	13.0	
0.13	8	690	1.80	41	0.64	0.72	2.3	1.6	1.7	5600	8000																	
0.75	M 2SB 2	2800	2.6	68	0.88	1.81	4.6	2.1	2.0	25	10.6	FD 04	10	1700	1900	27	14.5	AFD 04	10	1900	27	14.1	FA 04	10	1900	27	14.4	
0.18	8	690	2.5	43	0.66	0.92	2.3	1.6	1.7	4800	7300																	
1.1	M 3SA 2	2870	3.7	69	0.84	2.74	4.6	1.8	1.7	34	15.5	FD 15	13	1000	1300	38	22	AFD 15	13	1300	38	21.4	FA 15	13	1300	38	23	
0.28	8	690	3.9	44	0.56	1.64	2.3	1.4	1.7	3400	5000																	
1.5	M 3LA 2	2880	5.0	69	0.85	3.69	4.7	1.9	1.8	40	17	FD 15	13	1000	1200	44	24	AFD 15	13	1200	44	23.4	FA 15	13	1200	44	24	
0.37	8	690	5.1	46	0.63	1.84	2.1	1.6	1.6	3300	5000																	
2.4	M 3LB 2	2900	7.9	75	0.82	5.6	5.4	2.1	2.0	61	23	FD 15	26	550	700	65	29	AFD 15	26	700	65	28	FA 15	26	700	65	30	
0.55	8	700	7.5	54	0.58	2.5	2.6	1.8	1.8	2000	3500																	
3	M 4SA 2	2920	9.8	72	0.85	7.1	5.6	2.0	1.8	162	36	FD 56	37	—	600	182	48	AFD 06	37	600	182	47	FA 06	37	600	182	50	
0.75	8	710	10.1	61	0.64	2.8	3.0	1.7	1.8	—	—				3400	3400												
4	M 4SB 2	2870	13.3	73	0.84	9.4	5.6	2.3	2.4	213	42	FD 56	37	—	500	223	55	AFD 06	37	500	223	54	FA 06	37	500	223	56	
1	8	690	13.8	66	0.62	3.5	2.9	1.9	1.8	—	—				3500	3500												
5.5	M 4LA 2	2870	18.3	75	0.84	12.6	6.1	2.4	2.5	270	51	FD 06	50	—	400	280	64	AFD 06	62	400	280	63	FA 06	50	400	280	65	
1.5	8	690	21	68	0.63	5.1	2.9	1.9	1.9	—	—				2400	2400												



2/12P **3000/500 min⁻¹ - S3 60/40%** **50 Hz**

frein c.c.														frein c.c. à entrefer fixe						frein c.a.								
FD														AFD						FA								
P _n		n	M _n	η	cosφ	In	$\frac{I_s}{I_n}$	$\frac{M_s}{M_n}$	$\frac{M_a}{M_n}$	J _m	IM B5	Mod	Mb	Z _o	J _m	IM B5	Mod	Mb	Z _o	J _m	IM B5	Mod	Mb	Z _o	J _m	IM B5		
kW		min ⁻¹	Nm	%		400V	A			x 10 ⁻⁴			Nm	1/h	x 10 ⁻⁴			Nm	1/h	x 10 ⁻⁴			Nm	1/h	x 10 ⁻⁴			
0.55	M 2SA 2	2820	1.86	64	0.89	1.39	4.2	1.6	1.7	25	10.6	FD 04	5	1000	1300	14.5	AFD 04	5	1300	12000	27	14.1	FA 04	5	1300	12000	27	14.4
0.09	12	430	2.0	30	0.63	0.69	1.8	1.9	1.8					8000														
0.75	M 3SA 2	2900	2.5	65	0.81	2.06	5.2	1.9	2.1	34	15.5	FD 15	13	700	900	22	AFD 15	13	900	7000	38	21.4	FA 15	13	900	7000	38	23
0.12	12	460	2.5	33	0.43	1.22	1.9	1.3	1.6					5000														
1.1	M 3LA 2	2850	3.7	65	0.85	2.87	4.5	1.6	1.8	40	17	FD 15	13	700	900	24	AFD 15	13	900	6000	44	23.4	FA 15	13	900	6000	44	24
0.18	12	430	4.0	26	0.54	1.85	1.5	1.3	1.5					4000														
1.5	M 3LB 2	2900	4.9	67	0.86	3.76	5.6	1.9	1.9	54	21	FD 15	13	700	900	27	AFD 15	13	900	5000	58	26	FA 15	13	900	5000	58	28
0.25	12	440	5.4	36	0.46	2.18	1.8	1.7	1.8					3800														
2	M 3LC 2	2850	6.7	70	0.84	4.9	4.9	1.8	1.7	61	23	FD 55	18	—	700	29	AFD 15	26	700	3500	65	28	FA 15	18	700	3500	65	30
0.3	12	450	6.4	38	0.47	2.4	1.7	1.6	1.7					—	—													
3	M 4SA 2	2920	9.8	74	0.87	6.7	6.8	2.3	1.9	213	42	FD 56	37	—	450	55	AFD 06	37	450	3000	223	54	FA 06	37	450	3000	223	56
0.5	12	470	10.2	51	0.43	3.3	2.0	1.7	1.6					—	3000													
4	M 4LA 2	2920	13.1	75	0.89	8.6	5.9	2.4	2.3	270	51	FD 56	37	—	400	64	AFD 06	37	400	2800	280	63	FA 06	37	400	2800	280	65
0.7	12	460	14.5	53	0.44	4.3	1.9	1.7	1.6					—	2800													

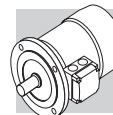

M13 DIMENSIONS MOTEURS

BN - IM B14

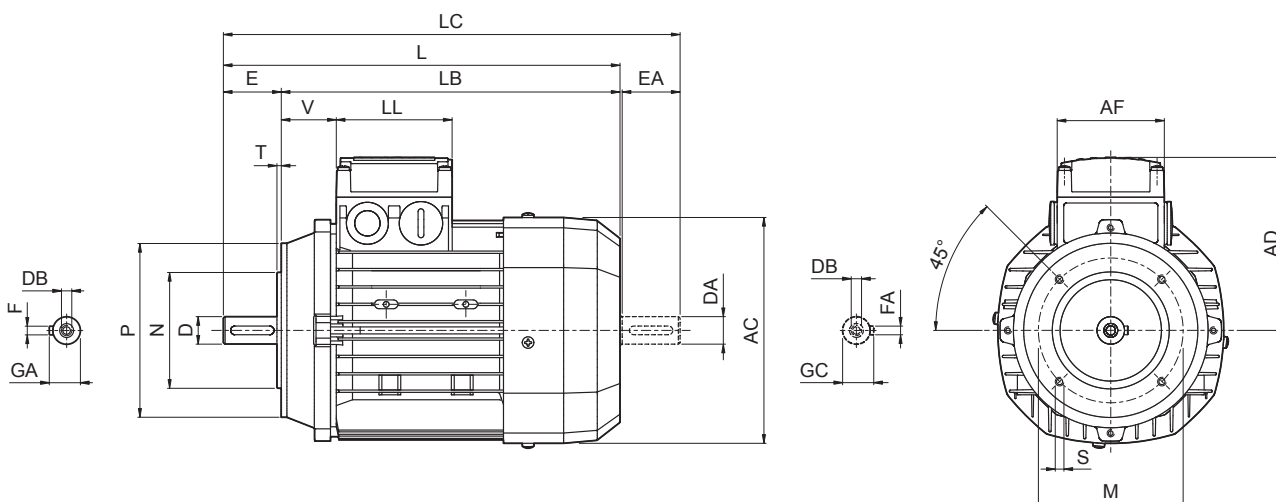

	Arbre					Bride					Moteur							
	D DA	E EA	DB	GA GC	F FA	M	N	P	S	T	AC	L	LB	LC	AD	AF	LL	V
BN 56	9	20	M3	10.2	3	65	50	80	M5	2.5	110	185	165	207	91	74	80	34
BN 63	11	23	M4	12.5	4	75	60	90	M5	2.5	121	207	184	232	95	74	80	26
BN 71	14	30	M5	16	5	85	70	105	M6	2.5	138	249	219	281	108	74	80	37
BN 80	19	40	M6	21.5	6	100	80	120	M6	3	156	274	234	315	119	74	80	38
BN 90	24	50	M8	27	8	115	95	140	M8	3	176	326	276	378	133	98	98	44
BN 100	28	60	M10	31	8	130	110	160	M8	3.5	195	367	307	429	142	98	98	50
BN 112	28	60	M10	31	8	130	110	160	M8	3.5	219	385	325	448	157	98	98	52
BN 132	38	80	M12	41	10	165	130	200	M10	4	258	493	413	576	193	118	118	58

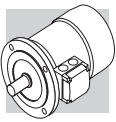

BN - IM B5

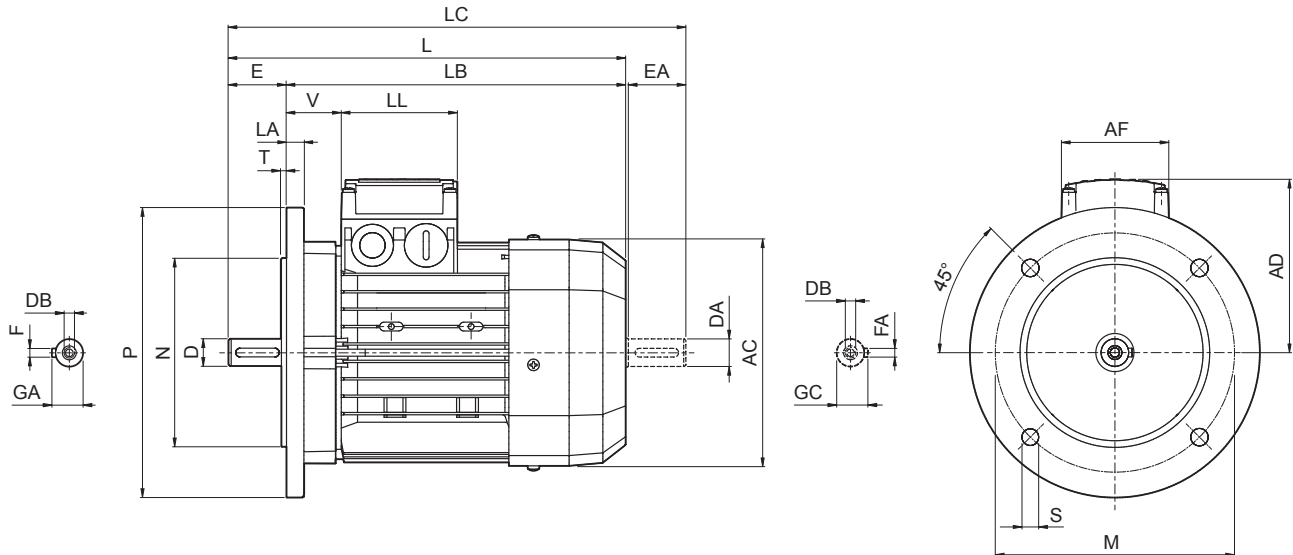

	Arbre					Bride						Moteur							
	D DA	E EA	DB	GA GC	F FA	M	N	P	S	T	LA	AC	L	LB	LC	AD	AF	LL	V
BN 56	9	20	M3	10.2	3	100	80	120	7	3	8	110	185	165	207	91	74	80	34
BN 63	11	23	M4	12.5	4	115	95	140	9.5	3	10	121	207	184	232	95	74	80	26
BN 71	14	30	M5	16	5	130	110	160	9.5	3	10	138	249	219	281	108	74	80	37
BN 80	19	40	M6	21.5	6	165	130	200	11.5	3.5	11.5	156	274	234	315	119	74	80	38
BN 90	24	50	M8	27	8	165	130	200	11.5	3.5	11.5	176	326	276	378	133	98	98	44
BN 100	28	60	M10	31	8	215	180	250	14	4	14	195	367	307	429	142	98	98	50
BN 112	28	60	M10	31	8	215	180	250	14	4	15	219	385	325	448	157	98	98	52
BN 132	38	80	M12	41	10	265	230	300	14	4	20	258	493	413	576	193	118	118	58
BN 160 MR	42 38 (1)	110 80 (1)	M16 M12 (1)	45 41 (1)	12 10 (1)	300	250	350	18.5	5	15	258	562	452	645	193	118	118	218
BN 160 M	42 38 (1)	110 80 (1)	M16 M12 (1)	45 41 (1)	12 10 (1)	300	250	350	18.5	5	15	310	596	486	680	245	187	187	51
BN 160 L	42 38 (1)	110 80 (1)	M16 M12 (1)	45 41 (1)	12 10 (1)	300	250	350	18.5	5	15	310	596	486	680	245	187	187	51
BN 180 M	48 38 (1)	110 110 (1)	M16 M12 (1)	51.5 41 (1)	14 10 (1)	300	250	350	18.5	5	15	310	640	530	724	245	187	187	51
BN 180 L	48 42 (1)	110 110 (1)	M16 M16 (1)	51.5 45 (1)	14 12 (1)	300	250	350	18.5	5	18	348	708	598	823	261	187	187	52
BN 200 L	55 42 (1)	110 110 (1)	M20 M16 (1)	59 45 (1)	16 12 (1)	350	300	400	18.5	5	18	348	722	612	837	261	187	187	66

REMARQUE :

1) Ces dimensions se réfèrent à la deuxième extrémité de l'arbre.

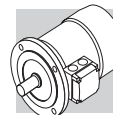

BN_FD ; BN_AFD - IM B14

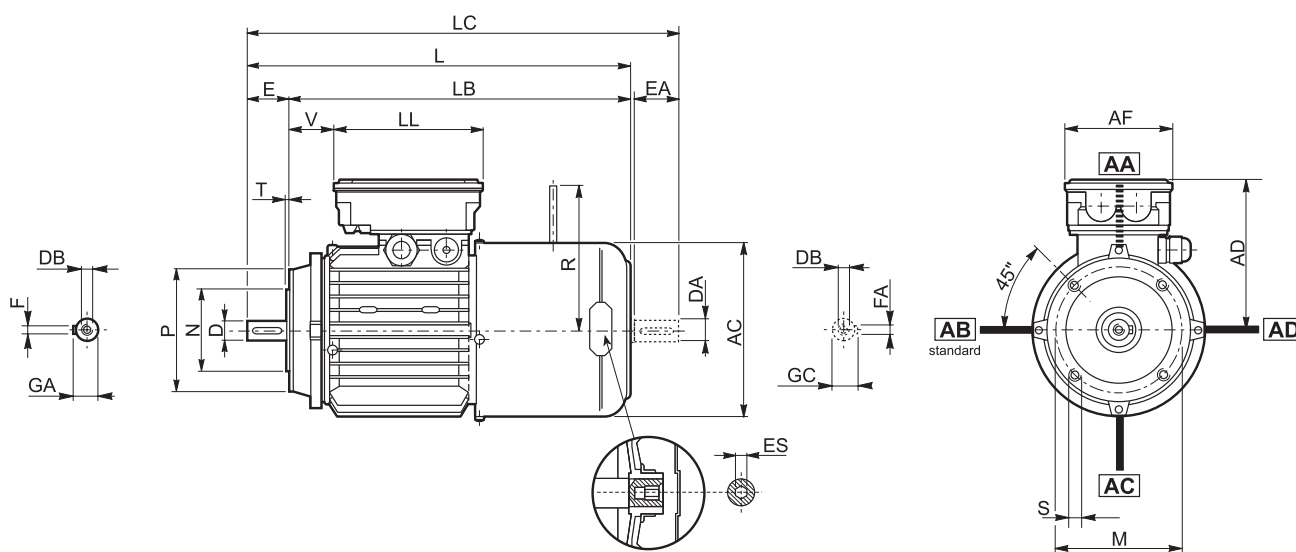

	Arbre					Bride					Moteur									
	D DA	E EA	DB	GA GC	F FA	M	N	P	S	T	AC	L	LB	LC	AD	AF	LL	V	R	ES
BN 63	11	23	M4	12.5	4	75	60	90	M5	2.5	121	272	249	297	122	98	133	14	96	5
BN 71	14	30	M5	16	5	85	70	105	M6	2.5	138	310	280	342	135	98	133	25	103	5
BN 80	19	40	M6	21.5	6	100	80	120	M6	3	156	346	306	388	146	98	133	41	129	5
BN 90 S	24	50	M8	27	8	115	95	140	M8	3	176	409	359	461	149	110	165	39	129	6
BN 90 L	24	50	M8	27	8	115	95	140	M8	3	176	409	359	461	146	110	165	39	160	6
BN 100	28	60	M10	31	8	130	110	160	M8	3.5	195	458	398	521	158	110	165	62	160	6
BN 112	28	60	M10	31	8	130	110	160	M8	3.5	219	484	424	547	173	110	165	73	199	6
BN 132	38	80	M12	41	10	165	130	200	M10	4	258	603	523	686	210	140	188	122	204 (1)	6

REMARQUE :

1) Pour frein FD07 et AFD valeur R=226.

L'hexagone ES n'est pas disponible avec l'option PS.

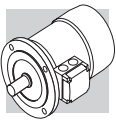

BN_FD ; BN_AFD - IM B5

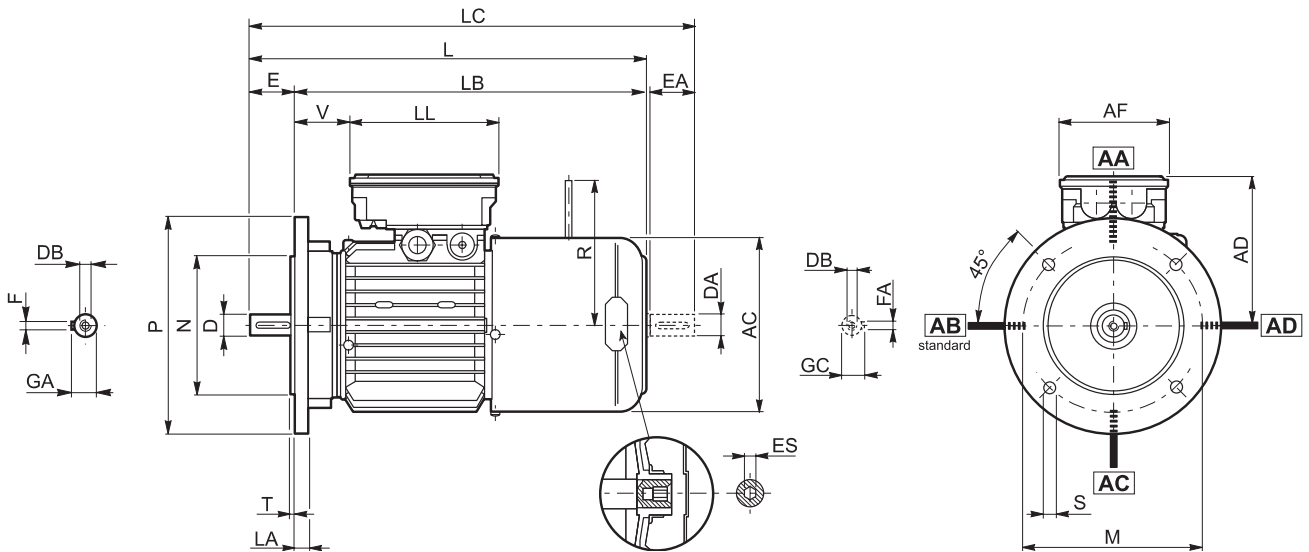

	Arbre					Bride						Moteur									
	D DA	E EA	DB	GA GC	F FA	M	N	P	S	T	LA	AC	L	LB	LC	AD	AF	LL	V	R	ES
BN 63	11	23	M4	12.5	4	115	95	140	9.5	3	10	121	272	249	297	122	98	133	14	96	5
BN 71	14	30	M5	16	5	130	110	160	9.5	3.5	10	138	310	280	342	135	98	133	25	103	5
BN 80	19	40	M6	21.5	6	165	130	200	11.5	3.5	11.5	156	346	306	388	146	98	133	41	129	5
BN 90 S	24	50	M8	27	8	165	130	200	11.5	3.5	11.5	176	409	359	461	149	110	165	39	129	6
BN 90 L	24	50	M8	27	8	165	130	200	11.5	3.5	11.5	176	409	359	461	146	110	165	39	160	6
BN 100	28	60	M10	31	8	215	180	250	14	4	14	195	458	398	521	158	110	165	62	160	6
BN 112	28	60	M10	31	8	215	180	250	14	4	15	219	484	424	547	173	110	165	73	199	6
BN 132	38	80	M12	41	10	265	230	300	14	4	20	258	603	523	686	210	140	188	122	204 (2)	6
BN 160 MR	42 38 (1)	110 80 (1)	M16 M12 (1)	45 41 (1)	12 10 (1)	300	250	350	18.5	5	15	258	672	562	755	210	140	188	161	226	6
BN 160 M	42 38 (1)	110 80 (1)	M16 M12 (1)	45 41 (1)	12 10 (1)	300	250	350	18.5	5	15	310	736	626	820	245	187	187	51	266	—
BN 160 L	42 38 (1)	110 80 (1)	M16 M12 (1)	45 41 (1)	12 10 (1)	300	250	350	18.5	5	15	310	736	626	820	245	187	187	51	266	—
BN 180 M	48 38 (1)	110 80 (1)	M16 M12 (1)	51.5 41 (1)	14 10 (1)	300	250	350	18.5	5	15	310	780	670	864	245	187	187	51	266	—
BN 180 L	48 42 (1)	110 110 (1)	M16 M16 (1)	51.5 45 (1)	14 12 (1)	300	250	350	18.5	5	18	348	866	756	981	261	187	187	52	305	—
BN 200 L	55 42 (1)	110 110 (1)	M20 M16 (1)	59 45 (1)	16 12 (1)	350	300	400	18.5	5	18	348	878	768	993	261	187	187	64	305	—

REMARQUE :

- 1) Ces dimensions se réfèrent à la deuxième extrémité de l'arbre.
- 2) Pour frein FD07 et AFD valeur R=226.

L'hexagone ES n'est pas disponible avec l'option PS.

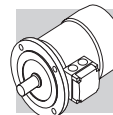

BN_FA - IM B14

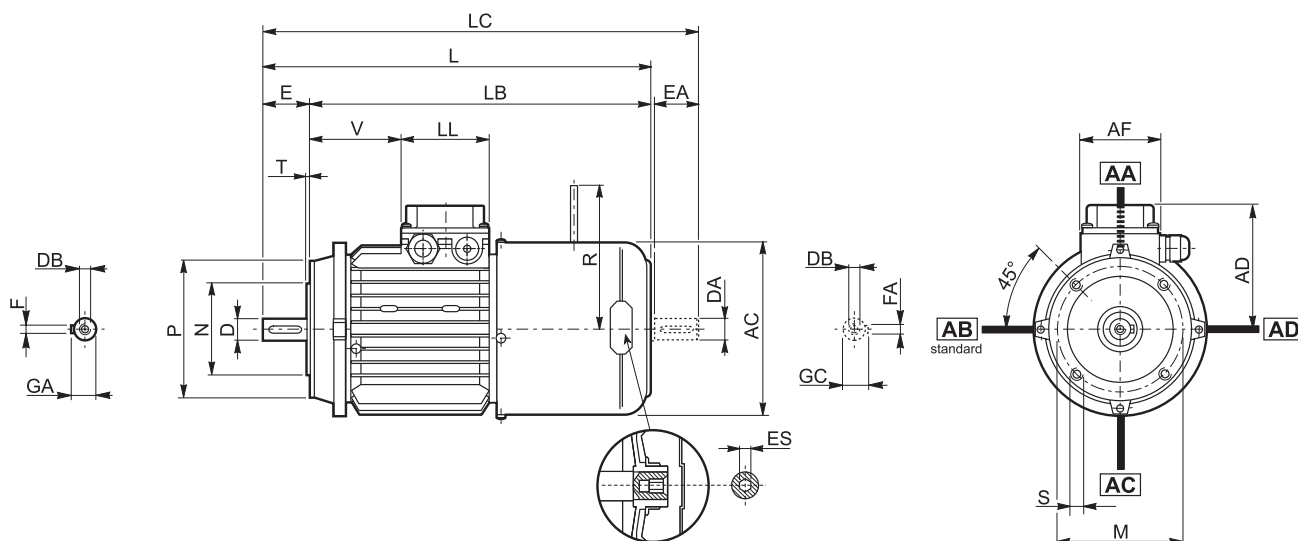

	Arbre					Bride					Moteur									
	D DA	E EA	DB	GA GC	F FA	M	N	P	S	T	AC	L	LB	LC	AD	AF	LL	V	R	ES
BN 63	11	23	M4	12.5	4	75	60	90	M5	2.5	121	272	249	119	95	74	80	26	116	5
BN 71	14	30	M5	16	5	85	70	105	M6	2.5	138	310	280	342	108	74	80	68	124	5
BN 80	19	40	M6	21.5	6	100	80	120	M6	3	156	346	306	388	119	74	80	83	134	5
BN 90	24	50	M8	27	8	115	95	140	M8	3	176	409	359	461	133	98	98	95	160	6
BN 100	28	60	M10	31	8	130	110	160	M8	3.5	195	458	398	521	142	98	98	119	160	6
BN 112	28	60	M10	31	8	130	110	160	M8	3.5	219	484	424	547	157	98	98	128	198	6
BN 132	38	80	M12	41	10	165	130	200	M10	4	258	603	523	686	193	118	118	180	200 (1)	6

REMARQUE :

1) Pour frein FA07 valeur R=217.

Les dimensions AD, AF, LL et V relatives à la boîte à bornes des moteurs BN...FA équipés d'alimentation séparée du frein (option SA) sont identiques à celles des moteurs BN...FD et AFD de la même taille.

L'hexagone ES n'est pas disponible avec l'option PS.

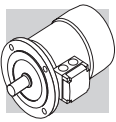

BN_FA - IM B5

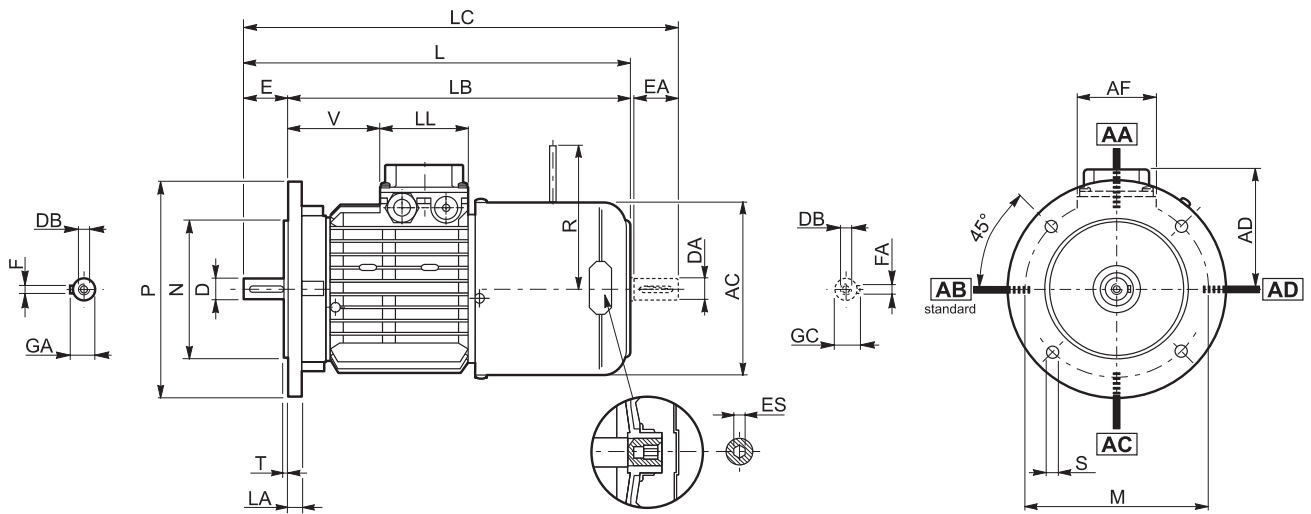

	Arbre					Bride						Moteur									
	D DA	E EA	DB	GA GC	F FA	M	N	P	S	T	LA	AC	L	LB	LC	AD	AF	LL	V	R	ES
BN 63	11	23	M4	12.5	4	115	95	140	9.5	3	10	121	272	249	297	95	74	80	26	116	5
BN 71	14	30	M5	16	5	130	110	160	9.5	3.5	10	138	310	280	342	108	74	80	68	124	5
BN 80	19	40	M6	21.5	6	165	130	200	11.5	3.5	11.5	156	346	306	388	119	74	80	83	134	5
BN 90	24	50	M8	27	8	165	130	200	11.5	3.5	11.5	176	409	359	461	133	98	98	95	160	6
BN 100	28	60	M10	31	8	215	180	250	14	4	14	195	458	398	521	142	98	98	119	160	6
BN 112	28	60	M10	31	8	215	180	250	14	4	15	219	484	424	547	157	98	98	128	198	6
BN 132	38	80	M12	41	10	265	230	300	14	4	20	258	603	523	686	193	118	118	180	200 (2)	6
BN 160 MR	42 38 (1)	110 80 (1)	M16 M12 (1)	45 41 (1)	12 10 (1)	300	250	350	18.5	5	15	258	672	562	755	193	118	118	218	217	6
BN 160 M	42 38 (1)	110-80 (1)	M16 M12 (1)	45 41 (1)	12 10 (1)	300	250	350	18.5	5	15	310	736	626	820	245	187	187	51	247	—
BN 160 L	42 38 (1)	110 80 (1)	M16 M12 (1)	45 41 (1)	12 10 (1)	300	250	350	18.5	5	15	310	736	626	820	245	187	187	51	247	—
BN 180 M	48 38 (1)	110 80 (1)	M16 M12 (1)	51.5 41 (1)	14 10 (1)	300	250	350	18.5	5	15	310	780	670	864	245	187	187	51	247	—

REMARQUE :

- 1) Ces dimensions se réfèrent à la deuxième extrémité de l'arbre.
- 2) Pour frein FA07 valeur R=217.

Les dimensions AD, AF, LL et V relatives à la boîte à bornes des moteurs BN...FA équipés d'alimentation séparée du frein (option SA) sont identiques à celles des moteurs BN...FD et AFD de la même taille.

L'hexagone ES n'est pas disponible avec l'option PS.

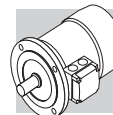

BN_BA - IM B14

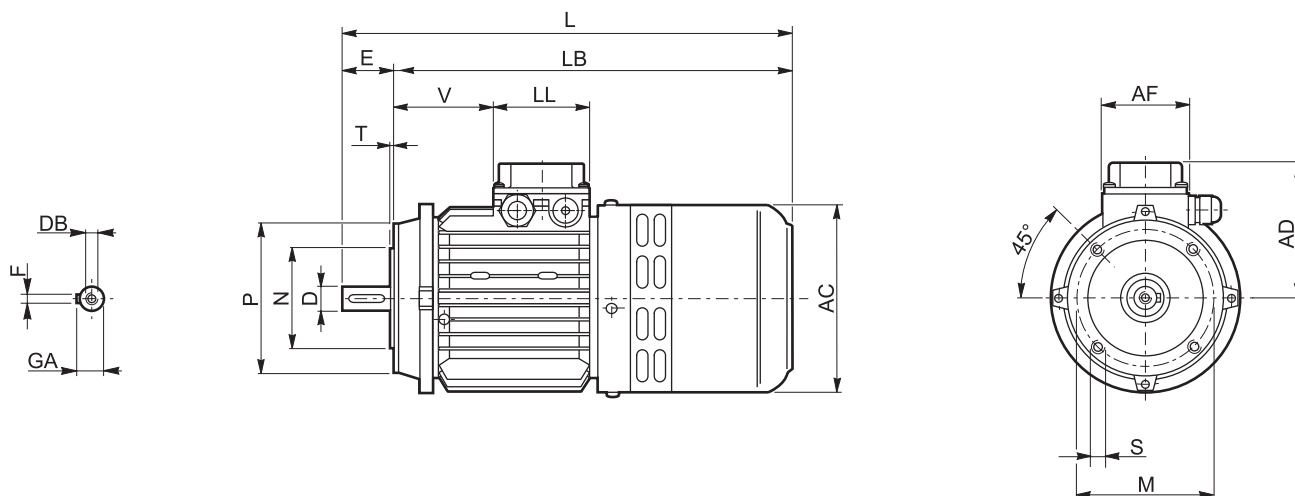

	Arbre					Bride					Moteur								
	D	E	DB	GA	F	M	N	P	S	T	AC	L	LB	LC	AD	AF	LL	V	
BN 63	11	23	M4	12.5	4	75	60	90	M5	2.5	124	298	275	95	74	80	28	34	
BN 71	14	30	M5	16	5	85	70	105	M6	2.5	138	327	297	108	74	80	68	26	
BN 80	19	40	M6	21.5	6	100	80	120	M6	3	156	372	332	119	74	80	83	37	
BN 90	24	50	M8	27	8	115	95	140	M8	3	176	425	375	133	98	98	95	38	
BN 100	28	60	M10	31	8	130	110	160	M8	3.5	195	477	417	142	98	98	119	44	
BN 112	28	60	M10	31	8	130	110	160	M8	3.5	219	500	440	157	98	98	128	50	
BN 132	38	80	M12	41	10	165	130	200	M10	4	258	638	558	193	118	118	180	52	

REMARQUE :

Les dimensions AD, AF, LL et V relatives à la boîte à bornes des moteurs BN...BA équipés d'alimentation séparée du frein (option SA) sont identiques à celles des moteurs BN...FD et AFD de la même taille.

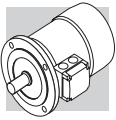

BN_BA - IM B5

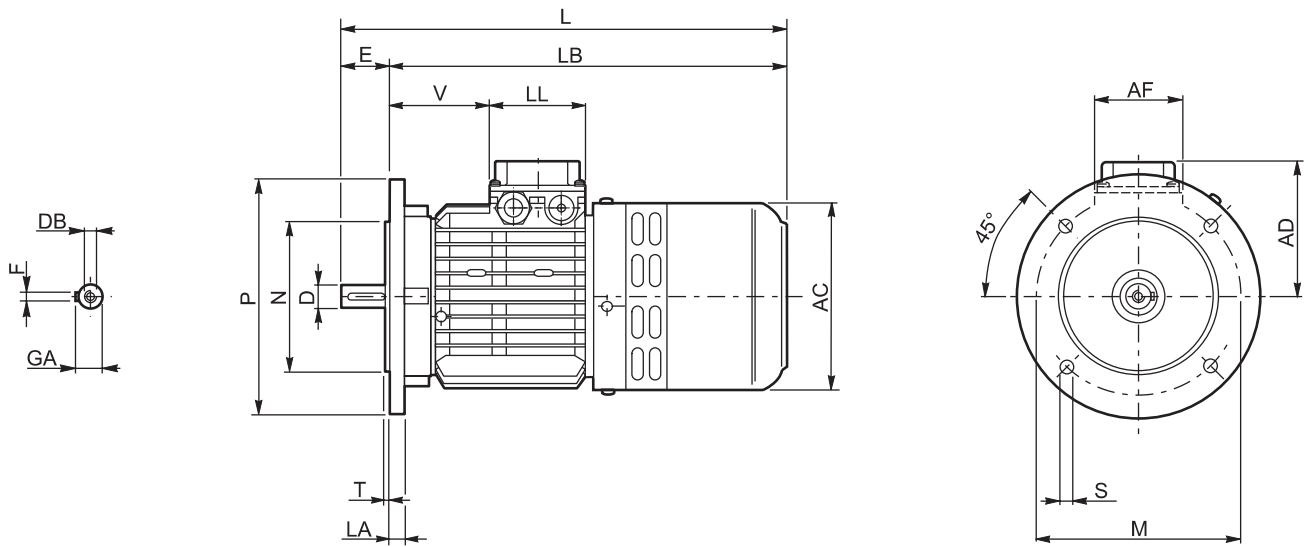

	Arbre				Bride							Moteur							
	D	E	DB	GA	F	M	N	P	S	T	LA	AC	L	LB	LC	AD	AF	LL	V
BN 63	11	23	M4	12.5	4	115	95	140	9.5	3	10	124	298	275	95	74	80	28	34
BN 71	14	30	M5	16	5	130	110	160	9.5	3.5	10	138	327	297	108	74	80	68	26
BN 80	19	40	M6	21.5	6	165	130	200	11.5	3.5	11.5	156	372	332	119	74	80	83	37
BN 90	24	50	M8	27	8	165	130	200	11.5	3.5	11.5	176	425	375	133	98	98	95	38
BN 100	28	60	M10	31	8	215	180	250	14	4	14	195	477	417	142	98	98	119	44
BN 112	28	60	M10	31	8	215	180	250	14	4	15	219	500	440	157	98	98	128	50
BN 132	38	80	M12	41	10	265	230	300	14	4	20	258	638	558	193	118	118	180	52

REMARQUE :

Les dimensions AD, AF, LL et V relatives à la boîte à bornes des moteurs BN...BA équipés d'alimentation séparée du frein (option SA) sont identiques à celles des moteurs BN...FD et AFD de la même taille.

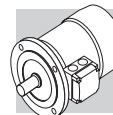

M

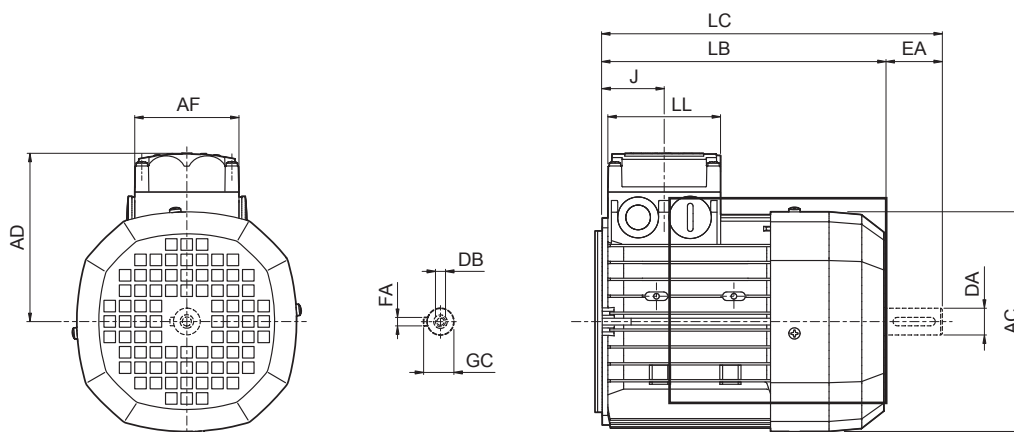

	Deuxième extrémité de l'arbre					Moteur						
	DA	EA	DB	FA	GC	AC	LB	LC	AF	LL	J	AD
M 0	9	20	M3	3	10.2	110	133	155	74	80	42	91
M 05	11	23	M4	4	12.5	121	165	191	74	80	48	95
M 1	14	30	M5	5	16	138	187	219	74	80	45	108
M 2 S	19	40	M6	6	21.5	156	202	245	74	80	44	119
M 3 S	28	60	M10	8	31	195	230	293	98	98	53.5	142
M 3 L	28	60	M10	8	31	195	262	325	98	98	53.5	142
M 4	38	80	M12	10	41	258	361	444	118	118	64.5	193
M 4 LC	38	80	M12	10	41	258	396	479	118	118	64.5	193
M 5 S	38	80	M12	10	41	310	418	502	187	187	77	245
M 5 L	38	80	M12	10	41	310	462	546	187	187	77	245

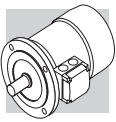

M_FD ; M_AFD

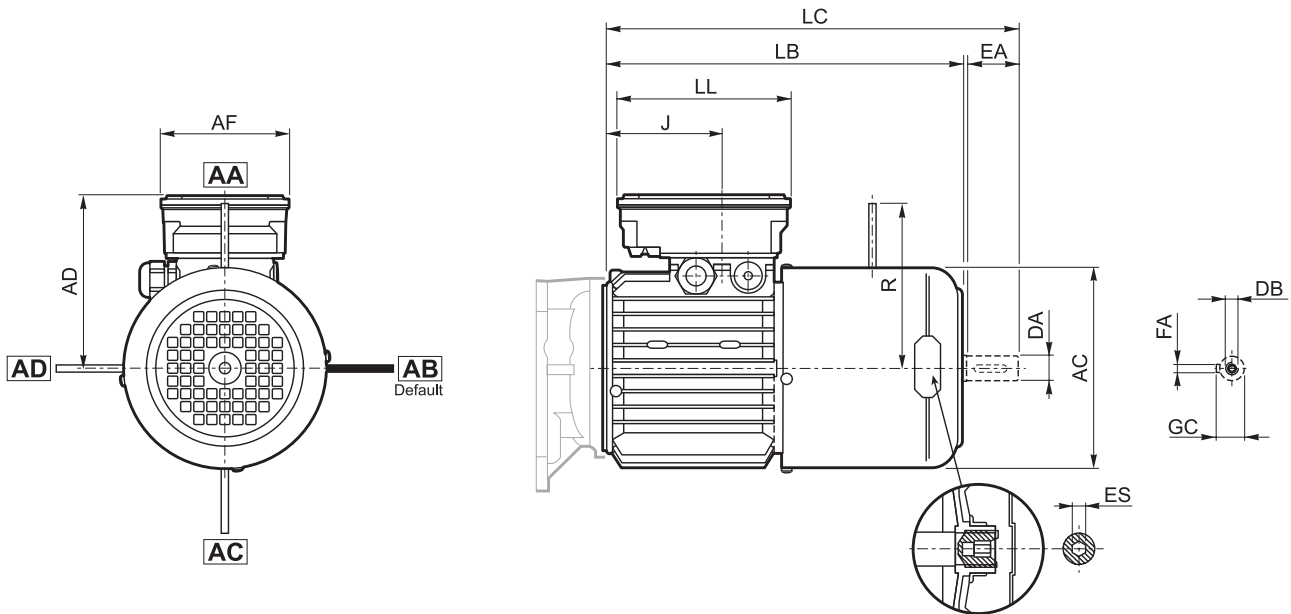

	Deuxième extrémité de l'arbre					Moteur								
	DA	EA	DB	FA	GC	AC	LB	LC	AF	LL	J	AD	R	ES
M 05	11	23	M4	4	12.5	121	231	256	98	133	48	122	96	5
M 1	14	30	M5	5	16	138	248	280	98	133	73	135	103	5
M 2 S	19	40	M6	6	21.5	156	272	314	98	133	88	146	129	5
M 3 S	28	60	M10	8	31	195	326	389	110	165	124.5	158	160	6
M 3 L	28	60	M10	8	31	195	353	416	110	165	124.5	158	160	6
M 4	38	80	M12	10	41	258	470	553	140	188	185.5	210	204 (1)	6
M 4 LC	38	80	M12	10	41	258	495	578	140	188	64.5	210	226	6
M 5 S	38	80	M12	10	41	310	558	642	187	187	77	245	266	—
M 5 L	38	80	M12	10	41	310	602	686	187	187	77	245	266	—

REMARQUE :

1) Pour frein FD07 et AFD07 valeur R=226.

L'hexagone ES n'est pas disponible avec l'option PS.

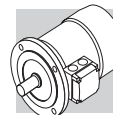

M_FA

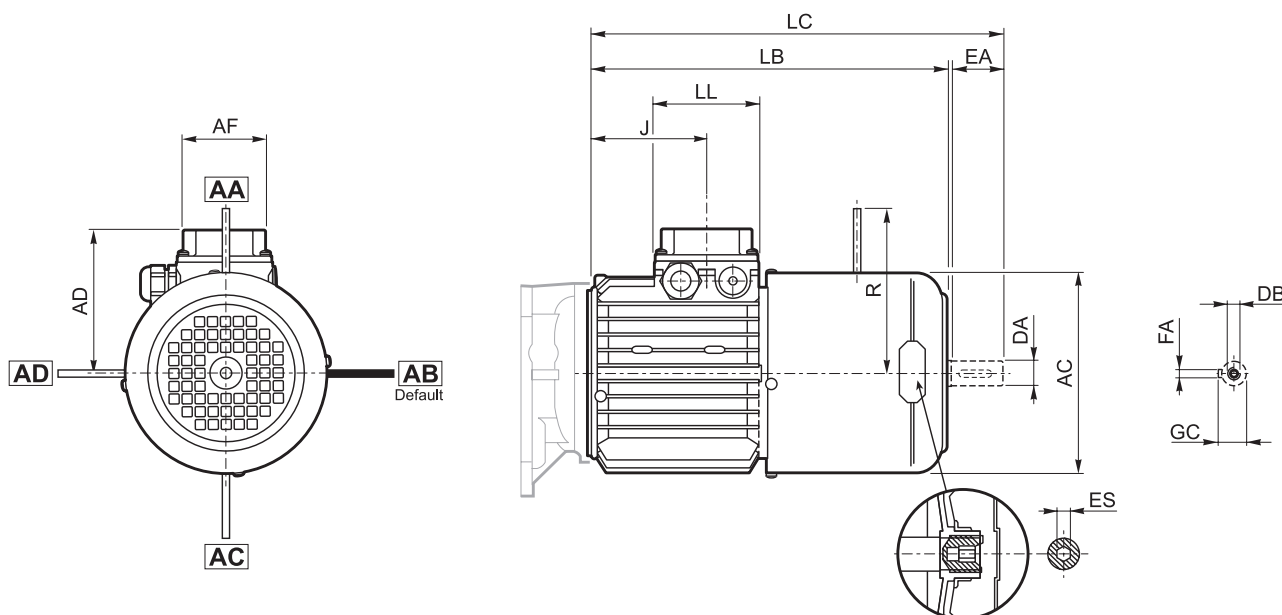

	Deuxième extrémité de l'arbre					Moteur								
	DA	EA	DB	FA	GC	AC	LB	LC	AF	LL	J	AD	R	ES
M 05	11	23	M4	4	12.5	121	231	256	74	80	48	95	116	5
M 1	14	30	M5	5	16	138	248	280	74	80	73	108	124	5
M 2 S	19	40	M6	6	21.5	156	272	314	74	80	88	119	134	5
M 3 S	28	60	M10	8	31	195	326	389	98	98	124.5	142	160	6
M 3 L	28	60	M10	8	31	195	353	416	98	98	124.5	142	160	6
M 4	38	80	M14	10	41	258	470	553	118	118	185.5	193	200 (1)	6
M 4 LC	38	80	M14	10	41	258	495	578	118	118	64.5	193	217	6
M 5 S	38	80	M12	10	41	310	558	642	187	187	77	245	247	—
M 5 L	38	80	M12	10	41	310	602	686	187	187	77	245	247	—

REMARQUE :

1) Pour frein FA07 valeur R=217.

Les dimensions AD, AF, LL et V relatives à la boîte à bornes des moteurs M...FA équipés d'alimentation séparée du frein (option SA) sont identiques à celles des moteurs M...FD et AFD de la même taille.

L'hexagone ES n'est pas disponible avec l'option PS.



INDEX DES RÉVISIONS

BR_CAT_VFW_STD_FRA_R02_1	
	Description
10	Mise à jour la figure au paragraphe "Mise en service des réducteurs série W".
21	Ajouté des informations sur l'option RB et RBO pour les réducteurs VF 44 et VFR 44.
170, 172	Ajouté des informations sur l'arbre HS pour les réducteurs VF 44, VF/W 44/75, VF/W 44/86.
110, 111 , 116, 117, 122, 123, 127	Ajouté des informations sur les réducteurs VF 30 avec l'entrée P56 B14.
180...186	Ajouté des informations sur les réducteurs VF-EP et W-EP.
219...223, 245...260	Mise à jour des informations sur les moteurs électriques avec frein AFD.

2015.01.12

Cette publication annule et remplace toutes les autres précédentes. Nous nous réservons le droit d'apporter toutes modifications à nos produits. La reproduction et la publication partielle ou totale de ce catalogue est interdite sans notre autorisation.



Depuis 1956, Bonfiglioli conçoit et réalise des solutions innovantes et fiables pour le contrôle et la transmission de puissance dans l'industrie et dans les machines automotrices et pour les énergies renouvelables.

HEADQUARTERS

Bonfiglioli Riduttori S.p.A.
Via Giovanni XXIII, 7/A
40012 Lippo di Calderara di Reno
Bologna (Italy)

tel: +39 051 647 3111
fax: +39 051 647 3126
bonfiglioli@bonfiglioli.com
www.bonfiglioli.com

BR_CAT_VFW_STD_FRA_R02_1

