

# Oil & Gas

Connect, monitor and control  
diverse remote sites and processes



Applications Include:

Drilling | Wellhead, Pump, Flow & Pressure Monitoring

Distribution | Leak Detection & Environmental Reporting

# Oil & Gas

Oil & Gas companies are increasingly going to the ends of the earth, and deeper below its surface, to find and extract reserves. These environments make it harder to maintain safety and keep operations running reliably. Regulatory demands are also creating new challenges, forcing companies to invest in the necessary technologies that will allow them to produce required data and develop new processes that help ensure safety and security.

How can companies effectively manage increasingly challenging environments and operate more safely and reliably in a competitive industry, all while meeting regulatory mandates? Traditional approaches and additional manpower are not practical options, because greater efficiency is also a requirement. The solution is not to do more of the same, but rather to build intelligence and control into operations. In short, there are tremendous benefits to maximizing technology to reliably connect, monitor or control diverse equipment and processes spread across remote locations.

Our customers are doing just that, using industrial automation and networking products from Red Lion Controls to upgrade and future-proof their systems. Red Lion products support the latest standards and protocols while providing backwards compatibility to preserve investments in legacy systems. This flexibility makes Red Lion products easy to deploy, thereby saving time and money during system rollouts and upgrades.



Oil & Gas companies worldwide rely on Red Lion to keep systems running safely and reliably around the clock, regardless of location. Whether located in the desert, ocean or ice field, Red Lion offers intelligent industrial solutions that provide the connectivity, monitoring and control required to get the job done across applications that include:

## Drilling

There are many ways to take advantage of remote terminal units (RTUs) that interface with sensors, HMIs and other devices at the wellhead. For hydraulic fracturing operations, RTUs continuously monitor conditions and calculate the optimal chemical mix for injection while recording all materials used and data collected in the process. RTUs can also manage pumps, valves, jacks, lifts and other wellhead equipment. By using industrial automation and real-time communications to manage activity at the wellhead, operators can remotely monitor and control the application and ensure continuous connectivity to host systems. Wellhead management systems can also be configured so that a single RTU manages multiple wellheads to limit the infrastructure required. The result is increased information from the field, more control over operations and less required capital investment.

## Wellhead Monitoring

Data loggers, RTUs and I/O modules aggregate data from sensors, and when combined with industrial and wireless communications systems enable effective remote monitoring and control. Programmable RTUs can be set to process input from a variety of sources and automatically adjust operations on the fly. Workers at the wellhead can also view data onsite with Red Lion's panel meters and HMIs. These capabilities enable operators to make real-time adjustments to keep systems within ideal operating parameters, while also collecting valuable performance data that can be used for predictive maintenance and advanced analytics.

## Pump Monitoring

RTUs and I/O modules can also be used to improve the energy efficiency, uptime and productivity of pumps by optimizing performance based on real-time information. With industrial automation solutions, data regarding stroke position readings, flow, pressure and other variables can be collected and used to adjust pump operations automatically without sending a technician on site. This reduces total cost of ownership while improving performance. Scalable I/O modules support many types of devices and sensors from a variety of manufacturers, and provide wired and wireless communications options. These processing and communications capabilities enable dynamic resource allocation so a single RTU can seamlessly service multiple wells. Easily programmable RTUs combined with reliable industrial networking options enable organizations to leverage assets while simplifying installation and integration.



## Flow & Pressure Monitoring

You can collect pressure and flow data from pipelines, valves, compressors and other assets through a wide range of sensors, RTUs and data loggers. Ensure the information collected is available as needed by taking advantage of numerous networking and protocol options to automatically provide data to other monitoring, predictive maintenance and M2M systems. Create solutions that remotely manage flow, automate block valves and shutdown systems, and adjust compressor air-fuel ratios.

## Distribution

The sense-and-respond capabilities that intelligent industrial automation and networking solutions provide are ideal for managing distribution at maximum efficiency. RTUs can process input from external sensors and other sources to continuously monitor pressure, flow, temperature and other conditions throughout the pipeline and make adjustments as required. Combining the RTU with a cellular router gives off-site personnel real-time visibility into operations and provides the means to remotely act on the information.

## Leak Detection & Environmental Reporting

There are plenty of sensors that can detect a leak. An intelligent control solution not only detects the leak, but also sends email and text alerts while automatically activating a shutdown valve and recording all activity on a data logger for instant download. Red Lion can turn your sensors into responsive systems that reduce risk, minimize losses and protect uptime.

These and other advanced applications don't require you to replace your entire infrastructure. Our industrial automation and networking products protect your investments by providing backwards compatibility with legacy systems, while introducing powerful new protocols and technologies to increase intelligence and control throughout operations. For example, Red Lion HMIs offer native drivers for Emerson ROC flow computers, provide standard Ethernet connectivity and built-in Web server capabilities to support advanced networking and control operations.

Red Lion will put you on the path to improved productivity and reliability with industrial automation and networking products that give you the ability to seamlessly connect, monitor and control your operations.



## Connect

Connectivity is at the heart of what Red Lion does, from our industry-leading line of Ethernet, Wi-Fi and cellular M2M products to the extensive protocol support and connectivity options that are built into our RTUs and HMIs. You'll find secure reliable communications options that provide visibility into remote operations, collect performance data from critical assets, and enable complete remote maintenance and troubleshooting.

Ethernet and cellular technology allow for the seamless connection of numerous I/O devices regardless of location. We offer industrial Ethernet switches, Wi-Fi radios, cellular routers, RTUs and other communications products. Supported standards include Ethernet, USB, RS-232 and RS-485 communications, HSPA, GSM, GPRS and EDGE cellular, 802.11a/b/g/n Wi-Fi and others. Red Lion's feature-rich products include:

- N-Tron and Sixnet series industrial Ethernet switches available in managed, unmanaged, monitored and PoE models.
- N-Tron series Wi-Fi radios that are IEEE 802.11a/b/g/n compliant and support data rates up to 300 Mb/s.
- Sixnet series cellular routers and RTUs support multiple 4G and 3G networks and native Modbus support to simplify connection to multi-node sites.
- Red Lion HMIs deliver the widest range of protocol support in the industry and have native drivers for hundreds of industrial control products used in Oil & Gas operations.
- Many of our products offer security features that meet NERC CIP requirements, including 1024-bit encryption, 802.1x compatibility, VPN support and IP blacklisting.

With products that enable the easy retrieval and logging of critical telemetry data, our industrial solutions provide real-time remote access to "always-on" monitoring equipment located in the field. The end result is streamlined data collection and improved network uptime, which improves safety and productivity by reducing the need for site visits.



### Industrial Ethernet Switches

Red Lion's new N-Tron and Sixnet series industrial Ethernet switches are designed to meet diverse networking environments. Built-in redundancy coupled with robust reliability ensures infrastructures like yours stay up and running around the clock.



### RTUs & I/O Modules

Red Lion's rugged RTUs and I/O provide simple yet powerful means to reliably monitor and control remote sites. Our compact automation systems can start small and grow as needs increase without requiring hardware replacement.

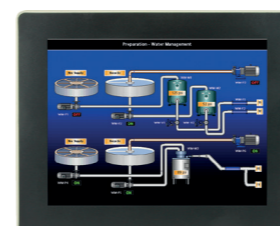

### Human Machine Interfaces

Red Lion's operator interface panels give you complete HMI functionality for PLCs, motor drives and other communications-capable devices. With Ethernet as standard on all models, you can network-enable any serial devices connected to the panel.



### Wi-Fi Radios

Red Lion's family of IEEE802.11a,b,g,n hardened wireless products provide a powerful solution for industrial applications. Data rates up to 300 Mb/s can be attained using the 802.11n MIMO wireless technology.

## Monitor

The protocols that our HMIs, panel displays and other products support make it easy to monitor multiple devices whether you are at the point of activity or thousands of miles away. You can get a true picture of performance by using the native drivers that are built into our HMIs to get data and status information from equipment, without having to add a protocol converter. By using our flexible Crimson® software or programmable RTUs, you can seamlessly take advantage of real-time data to create new applications that optimize performance and uptime. Red Lion's comprehensive support and flexibility take time out of installation and integration and add new capabilities to existing equipment.

- Red Lion HMIs not only provide sleek displays, but can double as data loggers to collect information for statistical analysis and offer emulators and databases to help you quickly create customized applications. And, with built-in Ethernet connectivity, you can easily share information to mobile devices and Web pages.
- The Crimson operator interface software supports Emerson ROC flow computers, cameras and more than 250 other industrial product protocols. The software converts input from these sources to display on the HMI and integrates with virtually any PLC, PC or SCADA system.
- Our products can even monitor themselves through self-diagnostic capabilities. For example, the N-View software that runs with N-Tron series Ethernet switches provides port-level status and integrates directly with control and monitoring applications running on HMIs.

The ability to process input from more sources and integrate with more systems and applications gives Red Lion customers the unmatched ability to monitor operations in real time and benefit from increased visibility.



## Control

Red Lion's powerful control features for drilling, wellhead, pump, pipeline and other operations have already been highlighted. But controlling equipment and processes is only one requirement for RTUs and other industrial automation products. They should also help operators control costs. Red Lion products do that with features that minimize deployment, integration and support.

First, our products help reduce capital equipment costs by performing multiple roles:

- Red Lion HMIs serve as their own protocol converters;
- HMIs and Sixnet series RTUs offer enough memory to work as data loggers;
- Sixnet series cellular automation routers combine data concentrator, router, cellular modem and RTU capabilities into a single device.

Because our products fulfill multiple roles, our customers have fewer devices to install, power, monitor and maintain. Second, we make our products easy to integrate by providing flexible configuration options, supporting open standards and leading protocols, and simplifying application development through software tools and preconfigured drivers. A product sampling follows:

- Sixnet series RTUs feature a Linux operating system so there are no proprietary operating systems and development environments to learn, and support multiple communication options, including Modbus and DNP3 for tight integration with enterprise systems.
- Our process control product line includes RTUs, distributed I/O modules and controllers that can enhance existing PLCs or form the foundation of advanced new control systems.
- Multifunctional capabilities plus various wireless and Ethernet connectivity options enable our products to play key roles in M2M systems.

Oil & Gas companies have to go farther to find new sources, and systems have to do more to provide the reliability, functionality and cost-effectiveness that today's operations require. Red Lion has become a trusted supplier to the Oil & Gas industry because our industrial automation and networking products go beyond basic functionality and provide the information, responsiveness and control to manage operations more efficiently. Our solutions make it easy for you to get the information you need and apply it to operations, with fewer onsite visits and minimal support from IT staff.

## Network Topologies

Red Lion's industrial automation and networking products can be configured in a multitude of ways, customized to suit specific applications. A few Oil & Gas network topology examples follow:

- Wellhead Monitoring
- Offshore Rig
- Gas Distribution
- Compressor Station

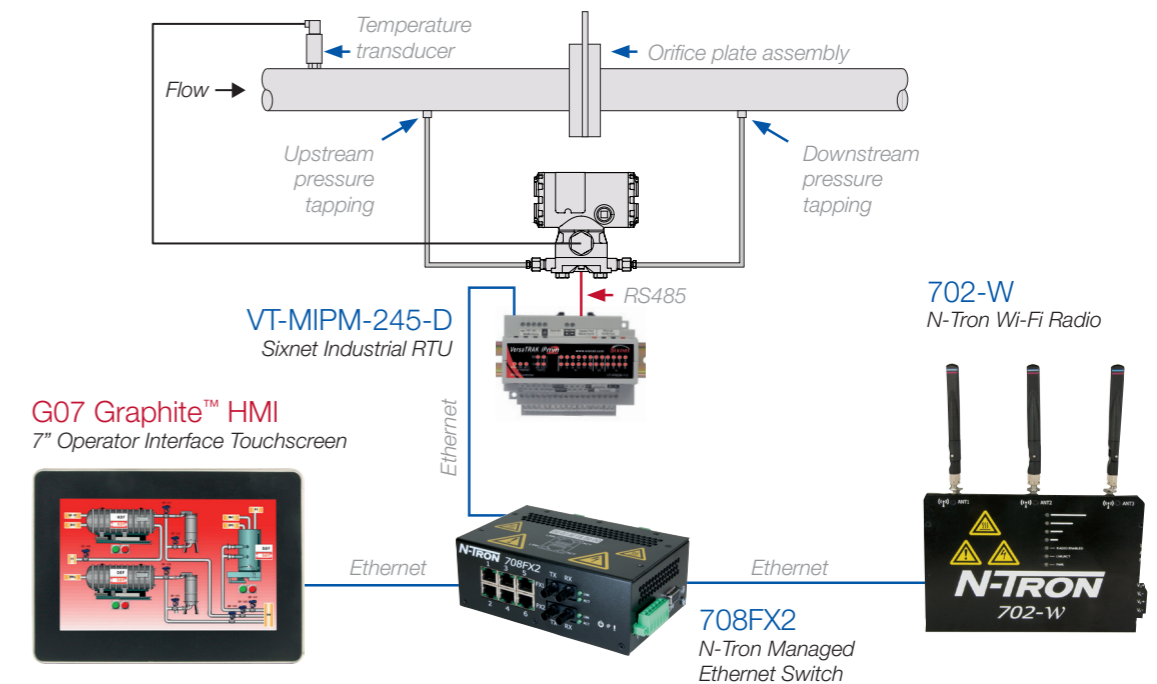

## Wellhead Monitoring

- Rugged RTU provides reliable local control
- AGA 3, 7 and 8 support for up to five meter runs
- Remote access via standard web browser
- Hardened Wi-Fi radio link

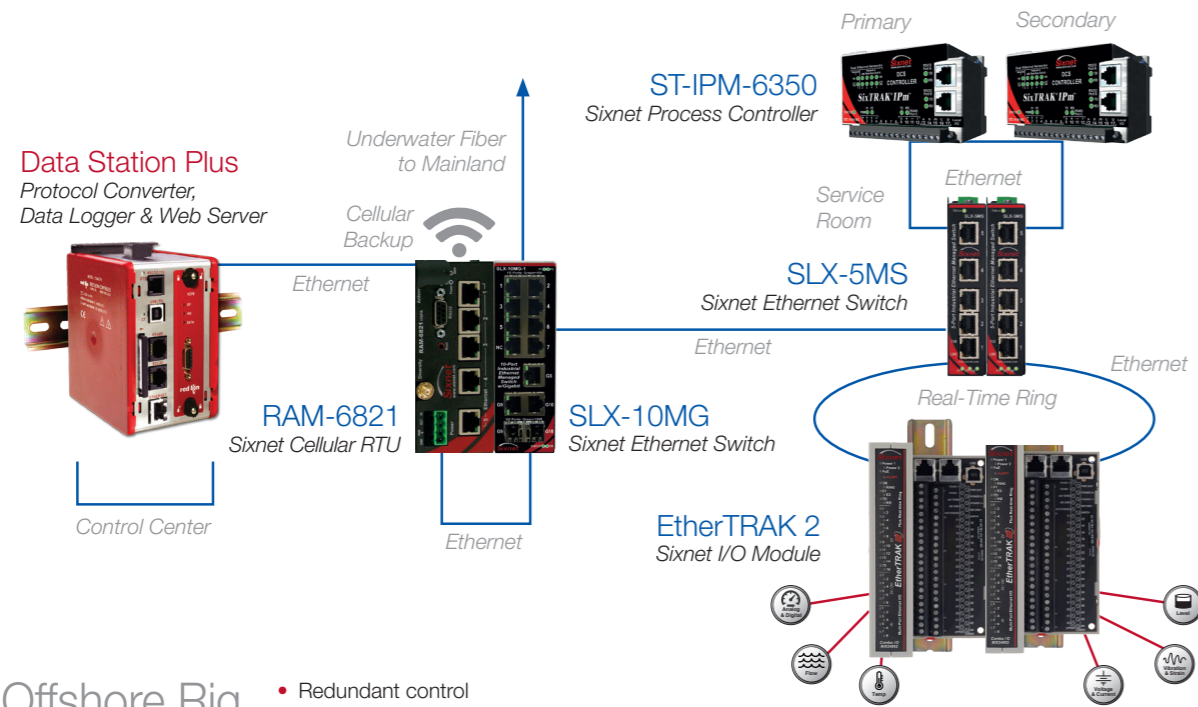

## Offshore Rig

- Redundant control
- Fault tolerant ring network
- Distributed I/O
- Cellular router offers advanced security
- Routers and controllers offer native DNP3 report by exception

## G10 Graphite™ HMI

10" Operator Interface Touchscreen

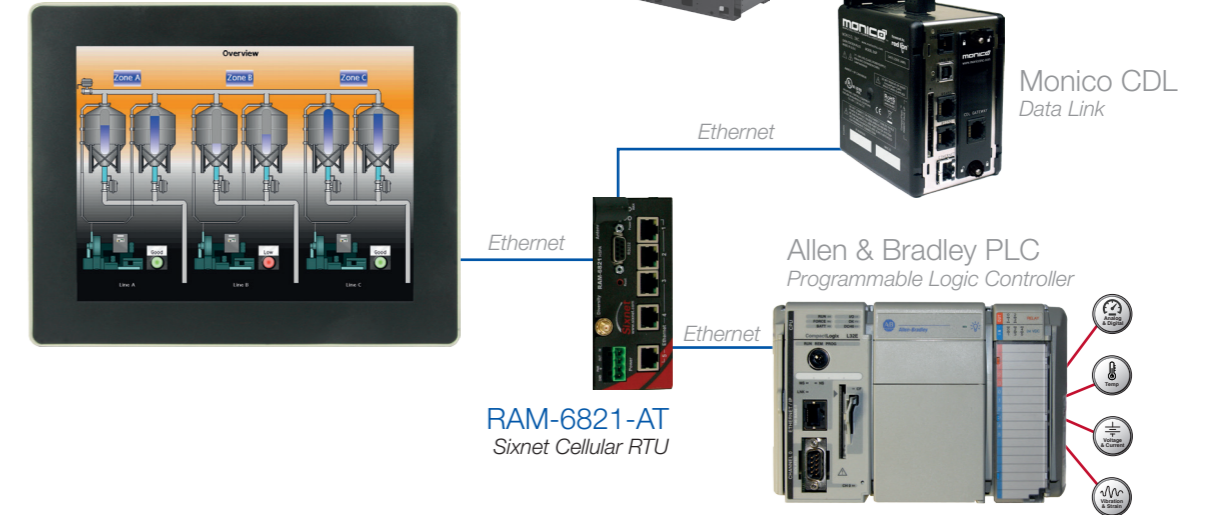

## Compressor Station

- Sunlight visible, UV hardened HMI supports 250+ protocols for complete device integration
- Data logging supports process analysis
- Built-in web server for remote control
- 4G/LTE offers high-speed, low latency connections

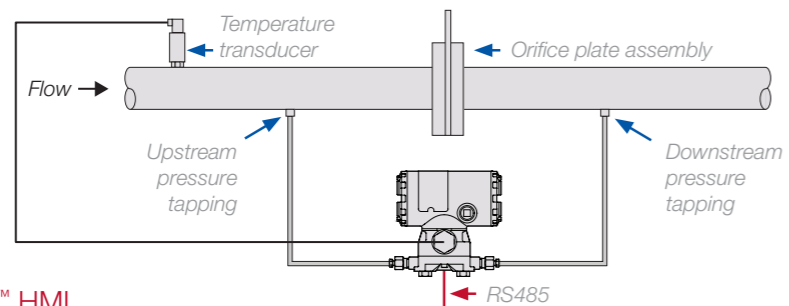

## G10 Graphite™ HMI

10" Operator Interface Touchscreen

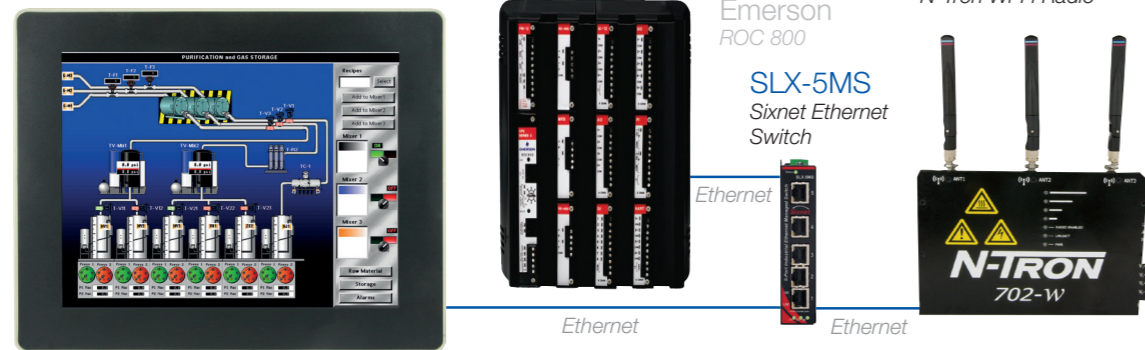

## Gas Distribution

- Sunlight visible, UV hardened HMI
- HMI supports 250+ protocols for system wide integration
- Native ROC protocol support
- Supports custom TLPs
- Data logging for process analysis
- Built-in web server for remote control

## About Red Lion

Red Lion is growing. In addition to the panel meters, HMIs and other industrial automation products that Red Lion customers have always trusted, we now offer a broad selection of communication technologies for industrial networks. Our networking products include industrial Ethernet switches, Wi-Fi devices and cellular M2M routers.

The end result? A comprehensive set of products that enable you to connect, monitor and control anything. From one device to a thousand devices. Connecting serially, via Ethernet, or over high-speed wireless networks. Speaking one protocol, or hundreds of protocols. On a single machine, across your factory, or spanning multiple sites all over the globe.



A comprehensive portfolio of industrial automation and networking solutions to **connect. monitor. control.**



## Industrial Automation

### Process Control

- PID Controllers
- Data Acquisition
- RTUs & I/O Modules
- Signal Conditioners
- Sensors

### HMIs & Panel Meters

- HMI Operator Panels
- Panel Meters
- Large LED Displays
- Industrial TV Displays

## Industrial Networking

### Ethernet Switches

- Unmanaged
- Monitored
- Managed
- PoE
- Routers
- Wi-Fi Radios

### Cellular M2M

- Cellular Routers
- Cellular RTUs

### Communication Converters

- Protocol Converters
- Media Converters
- Serial Converters

As the global experts in communication, monitoring and control for industrial automation and networking, Red Lion has been delivering innovative solutions for over forty years. Our award-winning technology enables companies worldwide to gain real-time data visibility that drives productivity. Product brands include Red Lion, N-Tron and Sixnet. With headquarters in York, Pennsylvania, the company has offices across the Americas, Asia-Pacific and Europe. For more information, please visit [www.redlion.net](http://www.redlion.net). Red Lion is a Spectris company.



**Americas**  
sales@redlion.net

**Asia-Pacific**  
asia@redlion.net

**Europe, Africa  
Middle East**  
europe@redlion.net

+31 (0) 33 472-3225

**Connect. Monitor. Control.**

[www.redlion.net](http://www.redlion.net)