



Ultrasonic flowmeter FFU

Non-contact flow measurement

SICK
Sensor Intelligence.

Non-contact flow measurement



Product description

The non-contact, ultrasonic flow sensor FFU detects the flow volumes of conductive and non-conductive liquids. Swimming against the current requires more strength than with the current – this is the simple fact on which ultrasonic flow measurement according to the phase difference process is based. The device has a compact design, and its wide range of possible applications means it can

also be used in restricted spaces. The seal-free sensor design, with high-quality polysulfone (Ultrason S) combined with enclosure rating IP 67, not only makes it possible to use the device in harsh ambient conditions, but also guarantees high process reliability. The large text display also helps ensure simple, fast and problem-free commissioning.

At a glance

- Flow sensor for conductive and non-conductive liquids
- No moving parts, compact design
- Process temperature up to 80 °C, process pressure up to 10 bar
- High chemical resistance thanks to seal-free sensor design
- Large display with membrane keyboard
- Integrated teaching tube detection
- Easy-to-clean, hygienic variants available (EHEDG certification and conformance with FDA), CIP capable

Your benefits

- Maintenance-free flow sensor; saves maintenance costs
- Adjustable measuring ranges, reduced number of variants
- Can be used for conductive and non-conductive liquids – fewer variants and lower storage costs
- Straight measuring tube reduces pressure loss, thus saving energy costs
- Sensor without seals increases process reliability and availability
- Flexible measurement system for all industries



Additional information

Detailed technical data.....3

Ordering information.....5

Dimensional drawings6

Connection type and diagram9

Recommended accessories.....9

Operation.....10

Mouting instructions.....10

Detailed technical data

Features

	NW 10	NW 15	NW 20	NW 25
Measuring principle	Ultrasonic sensor			
Medium	Fluids			
Nominal width measuring tube	NW 10	NW 15	NW 20	NW 25
Process temperature	0 °C ... +80 °C			
Process pressure	Max. 10 bar		Max. 6 bar	
EHEDG approval	✓			

Performance

	NW 10	NW 15	NW 20	NW 25
Minimum flow	0.3 l/min	0.9 l/min	3.5 l/min	5 l/min
Maximum flow	21 l/min	36 l/min	60 l/min	240 l/min
Inlet zone	10 cm	30 cm	50 cm	80 cm
Outlet zone	0 cm	5 cm	10 cm	20 cm
Conductivity	No limitation			
Accuracy	2 % (of final value)			
Reproducibility	0.5 %			
Resolution	0.003 l/min	0.006 l/min	0.012 l/min	0.03 l/min

Mechanics

	NW 10	NW 15	NW 20	NW 25
Process connection	G 1/2 1/2" NPT Clamp 11864	G 3/4 3/4" NPT Clamp 11864	G 1 1" NPT Clamp 11864	G 1 1/4 1 1/4" NPT Clamp 11864
Wetted parts	PSU			
Housing material	PSU			
Weight	340 g	350 g	420 g	460 g

Electronics

Supply voltage ¹⁾	18 V DC ... 30 V DC
Ripple ²⁾	≤ 5 V _{pp}
Power consumption ³⁾	≤ 180 mA
Initialization time	≤ 5 s
Protection class	III
Electrical connection	M12x1, 5-pin M12x1, 8-pin (depending on type)
Electronics ¹⁾	1 analog output: 4 mA ... 20 mA, 0 mA ... 20 mA current flow, 1 pulse/status output: PNP-transistor output for flow rate meter, empty pipe detection, flow monitoring / 1 analog output: 4 mA ... 20 mA, 0 mA ... 20 mA current flow, 2 pulse/status output: PNP-transistor output for flow rate meter, empty pipe detection, flow monitoring, 1 digital input (depending on type)
Impuls/frequency output	0 kHz ... 10 kHz
Puls width	≤ 1 s
Signal voltage HIGH	V _s - 2 V
Signal voltage LOW	≤ 2 V
Output current	< 100 mA
Inductive load	1 H
Capacitive load	100 nF
Response time ⁴⁾	Filter off 100 ms, filter low 300 ms, filter medium 1 s, filter strong 4.2 s
Enclosure rating	IP 67
Output load	< 500 Ohm
Lower signal level	3.8 mA ... 4 mA
Upper signal level	20 mA ... 20.5 mA

¹⁾ All connections are polarity protected. All outputs are overload and short-circuit protected.

²⁾ May not exceed or fall short of V_s tolerances.

³⁾ Without load.

⁴⁾ Analog output and display.

Ambient data

Ambient temperature, operation	0 °C ... +60 °C
Ambient temperature, storage	-20 °C ... +70 °C

Ordering information

Type code

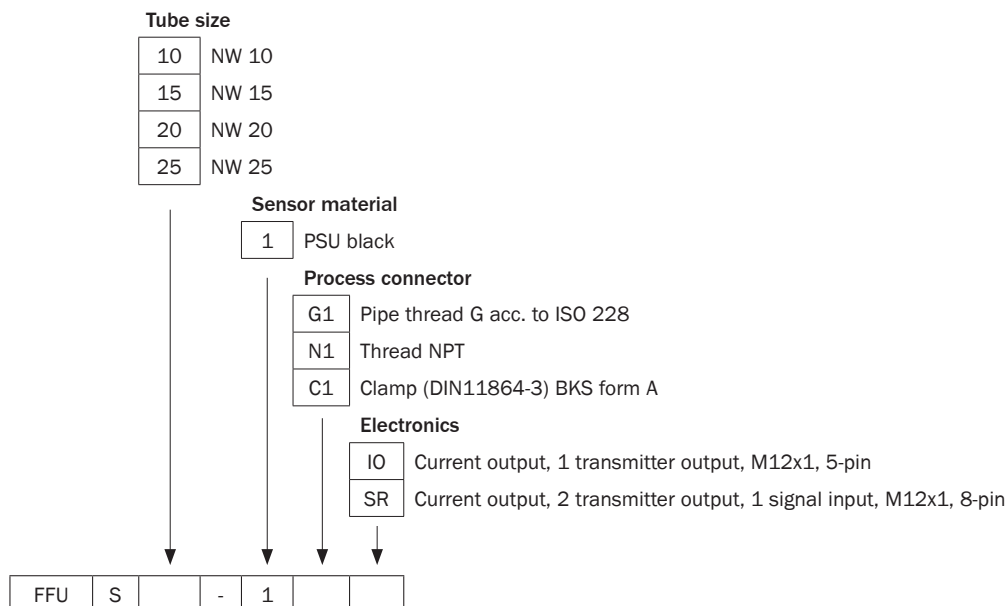

- **Electronics:** 1 analog output: 4 mA ... 20 mA, 0 mA ... 20 mA current flow, 1 pulse/status output: PNP-transistor output for flow rate meter, empty pipe detection, flow monitoring
- **Electrical connection:** M12x1, 5-pin

Process pressure	Process connection	Nominal width measuring tube	Maximum flow	Model name	Part No.
Max. 10 bar	G 1/2	NW 10	21 l/min	FFUS10-1G1IO	6041737
	G 3/4	NW 15	36 l/min	FFUS15-1G1IO	6041249
Max. 6 bar	G 1	NW 20	60 l/min	FFUS20-1G1IO	6041738
	G 1 1/4	NW 25	240 l/min	FFUS25-1G1IO	6041739

- **Electronics:** 1 analog output: 4 mA ... 20 mA, 0 mA ... 20 mA current flow, 2 pulse/status output: PNP-transistor output for flow rate meter, empty pipe detection, flow monitoring, 1 digital input
- **Electrical connection:** M12x1, 8-pin

Process pressure	Process connection	Nominal width measuring tube	Maximum flow	Model name	Part No.
Max. 10 bar	G 1/2	NW 10	21 l/min	FFUS10-1G1SR	6043743
	G 3/4	NW 15	36 l/min	FFUS15-1G1SR	6043744
Max. 6 bar	G 1	NW 20	60 l/min	FFUS20-1G1SR	6043745
	G 1 1/4	NW 25	240 l/min	FFUS25-1G1SR	6043746

Dimensional drawings

NW 10, process connection G 1/2

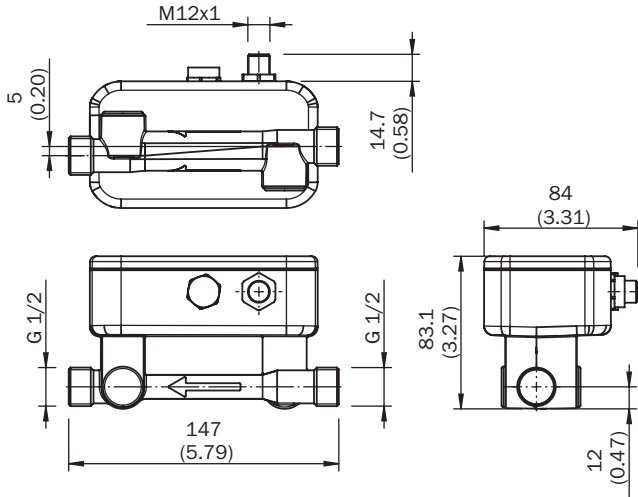

All dimensions in mm (inch)

NW 15, process connection G 3/4

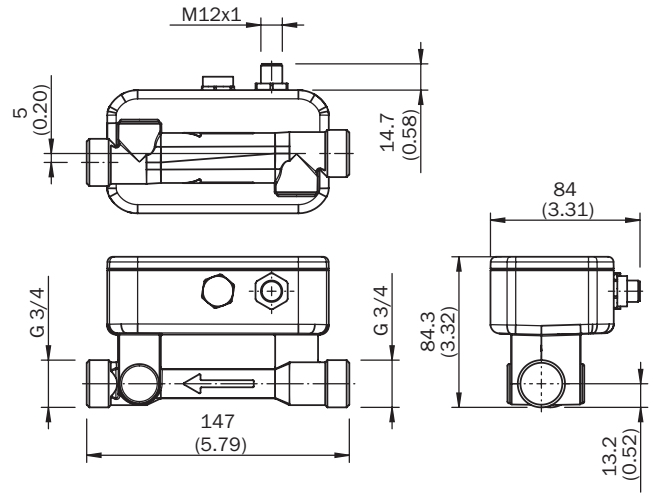

All dimensions in mm (inch)

NW 20, process connection G 1

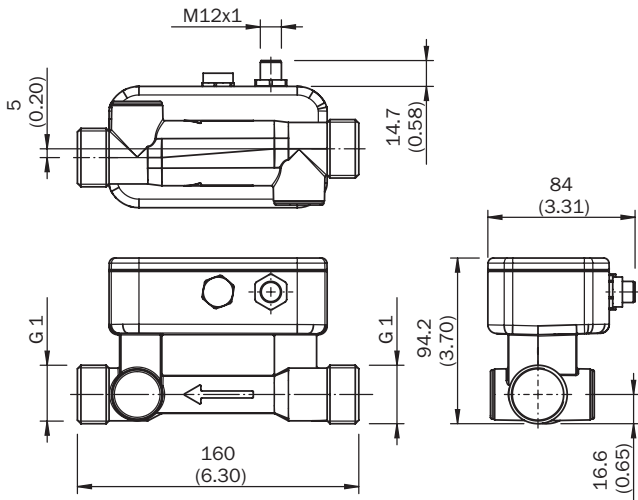

All dimensions in mm (inch)

NW 25, process connection G 1 1/4

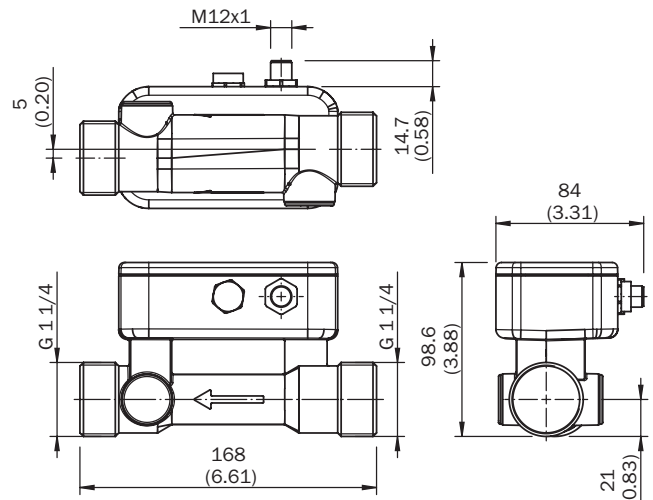

All dimensions in mm (inch)

NW 10, Clamp (DIN 11864-3)

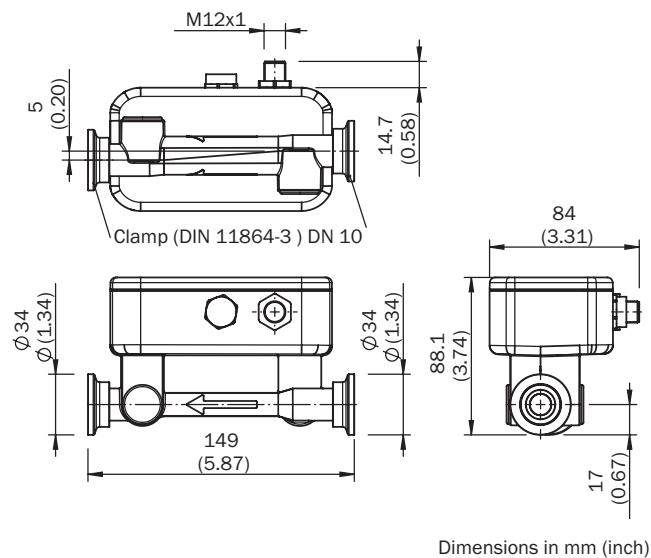

NW 15, Clamp (DIN 11864-3)

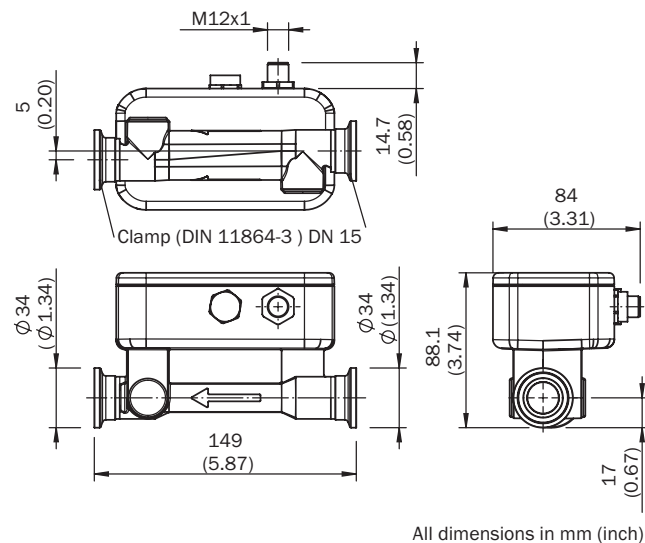

NW 20, Clamp (DIN 11864-3)

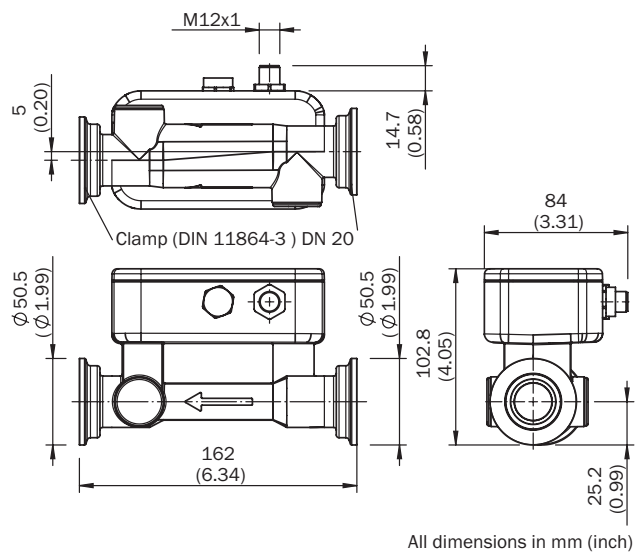

NW 25, Clamp (DIN 11864-3)

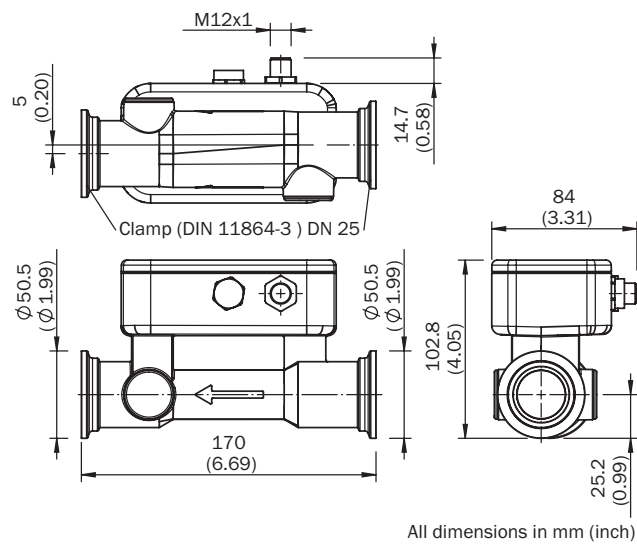

NW 10, 1/2" NPT

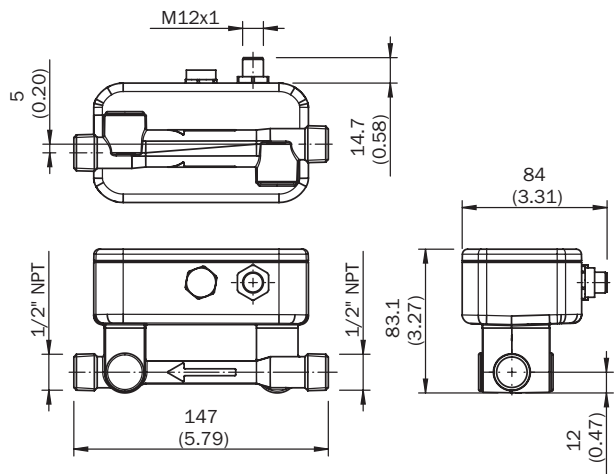

All dimensions in mm (inch)

NW 15, 3/4" NPT

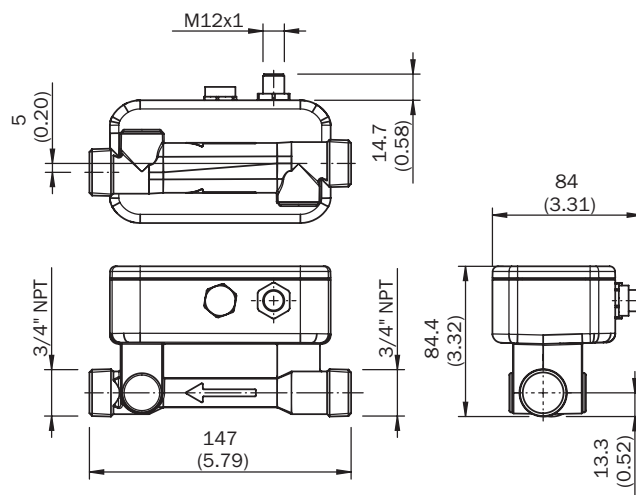

All dimensions in mm (inch)

NW 20, 1" NPT

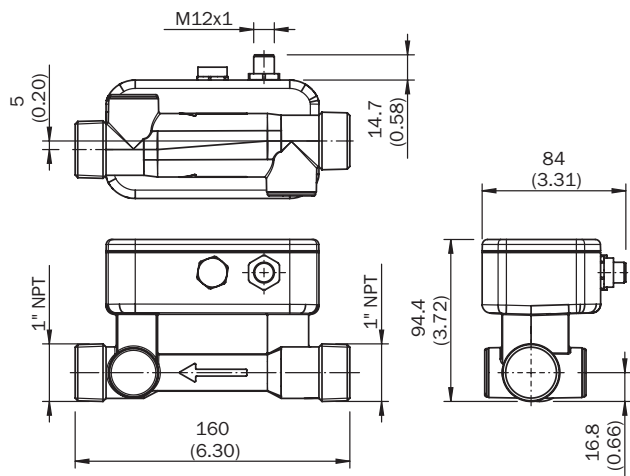

All dimensions in mm (inch)

NW 25, 1 1/4" NPT

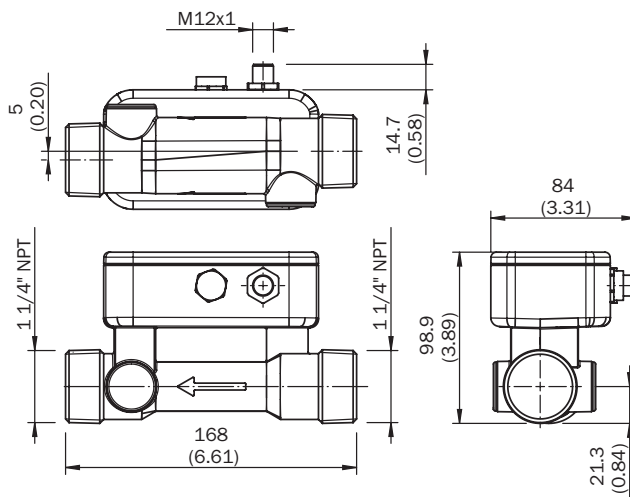

All dimensions in mm (inch)

Connection type and diagram

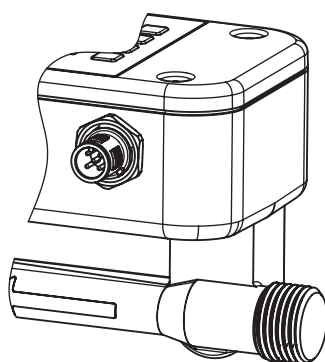

- ① L*: Supply voltage
- ② Q1: Digital output PNP/NPN
- ③ M: Ground
- ④ C: Communication
- ⑤ Q2: Analog current output

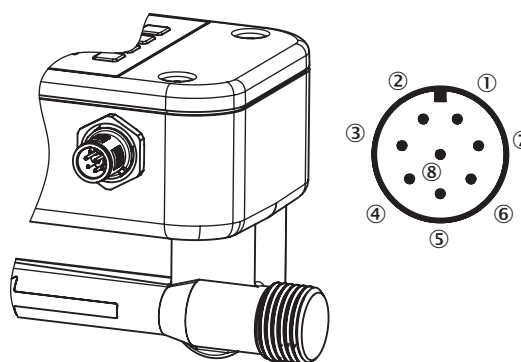

- ① L*: Supply voltage
- ② Q1: Digital output PNP/NPN
- ③ M: Ground
- ④ Q2: Digital output PNP/NPN
- ⑤ Q3: Analog current output
- ⑥ C: Communication
- ⑦ IN1: Digital input
- ⑧ No function

Recommended Accessories

Plug connectors and cables

Brief description	Model name	Part No.
Cable, M12, 5-pin, straight connector female with molded cable, 2 m, PVC	DOL-1205-G02M	6008899
Cable, M12, 5-pin, straight connector female with molded cable, 2 m, PUR halogen free	DOL-1205-G02MC	6025906
Cable, M12, 5-pin, straight connector female with molded cable, 5 m, PVC	DOL-1205-G05M	6009868
Cable, M12, 5-pin, straight connector female with molded cable, 5 m, PUR halogen free	DOL-1205-G05MC	6025907
Cable, M12, 5-pin, straight connector female with molded cable, 10 m, PVC	DOL-1205-G10M	6010544
Cable, M12, 5-pin, straight connector female with molded cable, 10 m, PUR halogen free	DOL-1205-G10MC	6025908
Cable, M12, 5-pin, angled connector female with molded cable, 2 m, PVC	DOL-1205-W02M	6008900
Cable, M12, 5-pin, angled connector female with molded cable, 2 m, PUR halogen free	DOL-1205-W02MC	6025909
Cable, M12, 5-pin, angled connector female with molded cable, 5 m, PVC	DOL-1205-W05M	6009869
Cable, M12, 5-pin, angled connector female with molded cable, 5 m, PUR halogen free	DOL-1205-W05MC	6025910
Cable, M12, 5-pin, angled connector female with molded cable, 10 m, PUR halogen free	DOL-1205-W10MC	6025911
Cable, M12, 8-pin, straight connector female with molded cable, 2 m, PVC	DOL-1208-G02MA	6020633
Cable, M12, 8-pin, straight connector female with molded cable, 2 m, PUR halogen free	DOL-1208-G02MC	6035620
Cable, M12, 8-pin, straight connector female with molded cable, 5 m, PVC	DOL-1208-G05MA	6020993
Cable, M12, 8-pin, straight connector female with molded cable, 5 m, PUR halogen free	DOL-1208-G05MC	6035621
Cable, M12, 8-pin, straight connector female with molded cable, 10 m, PVC	DOL-1208-G10MA	6022152
Cable, M12, 8-pin, straight connector female with molded cable, 10 m, PUR halogen free	DOL-1208-G10MC	6035622
Cable, M12, 8-pin, angled connector female with molded cable, 2 m, PVC	DOL-1208-W02MA	6020992
Cable, M12, 8-pin, angled connector female with molded cable, 2 m, PUR halogen free	DOL-1208-W02MC	6035623
Cable, M12, 8-pin, angled connector female with molded cable, 5 m, PVC	DOL-1208-W05MA	6021033
Cable, M12, 8-pin, angled connector female with molded cable, 5 m, PUR halogen free	DOL-1208-W05MC	6035624
Cable, M12, 8-pin, angled connector female with molded cable, 10 m, PUR halogen free	DOL-1208-W10MC	6035625

Operation



Select parameter or change values by using the arrow keys



Set: Save settings



Esc: Leaving current selection level / menu item

Display information:

- Current flow value in l/min
- Volume in l
- Bar graph with percentage value of current measurement range

Setting of:

- Analog output
- Pulse output
- Status output
- Measurement unit
- Creeping flow
- Medium calibration

Mounting instructions

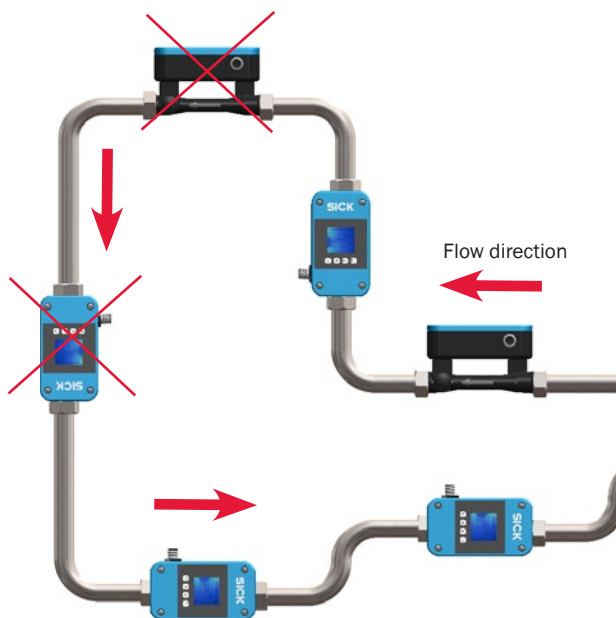

Tube has to be fully filled

Inlet and outlet paths

In order to receive an accurate volume measurement, it is necessary to observe inlet and outlet paths. The diameter of the tube - as given by the process connector of the FFU - should not change directly in front of the device and directly after the device. Minimum inlet and outlet paths are:

In applications where the flowmeter is exposed to high temperatures ($t \geq 60^\circ\text{C}$), the device should be mounted upside down:

Correct positioning

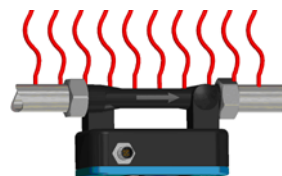

False positioning



Device nominal width	1/2"	3/4"	1"	1 1/4"
Inlet path	20 cm	30 cm	50 cm	60 cm
Outlet path	0 cm	5 cm	10 cm	10 cm

Notes

Worldwide presence with subsidiaries in the following countries:

Australia
Belgium/Luxembourg
Brasil
Ceská Republika
China
Danmark
Deutschland
España
France
Great Britain
India
Israel
Italia
Japan
Nederland
Norge

Österreich
Polska
Republic of Korea
Republika Slovenija
România
Russia
Schweiz
Singapore
Suomi
Sverige
Taiwan
Türkiye
United Arab Emirates
USA/Canada/México

Please find detailed addresses and additional representatives and agencies in all major industrial nations at www.sick.com

Handed over by:

Our Business Segment Expertise

Factory automation

With its intelligent sensors, safety systems, and automatic identification applications, SICK provides comprehensive solutions for factory automation.



- Non-contact detecting, counting, classifying, and positioning of any type of object
- Accident protection and personal safety using sensors, as well as safety software and services

Logistics automation

Sensors made by SICK form the basis for automating material flows and the optimization of sorting and warehousing processes.



- Automated identification with barcode and RFID reading devices for the purpose of sorting and target control in industrial material flow
- Detecting volume, position, and contours of objects and surroundings with laser measurement systems

Process automation

Optimized system solutions from SICK ensure efficient acquisition of environmental and process data in many industrial processes.



- Precise measurement of gases, liquids and dust concentrations for continuous monitoring of emissions and the acquisition of process data in production processes
- Gas flow measurements with maximum accuracy thanks to compact gas meters