

PM2 SERIES

Convergent Reflective Micro Photoelectric Sensor

MS-AJ
Sensor Mounting Stand

PM
Micro

PM2

NX5
Multi-voltage Type

VF

SU-7/SH
Amplifier-separated Type

SS-A5
Amplifier-separated Type

CHX-SC2
Sensor Checker

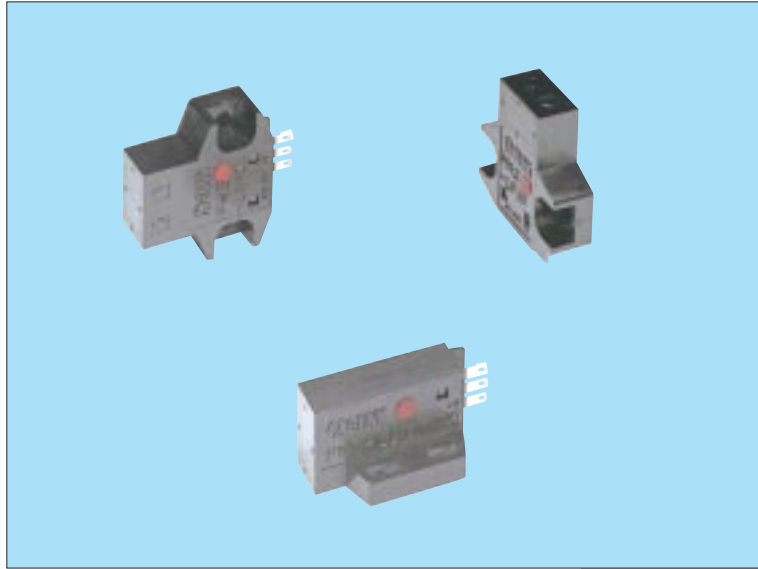

Convergent Reflection Sensing Ensures Stable Detection

CE Marked
Conforming to EMC Directive

Stable Detection by Convergent Reflective Mode

Stable detection characteristics are obtained since it is convergent reflective type and senses a limited area.

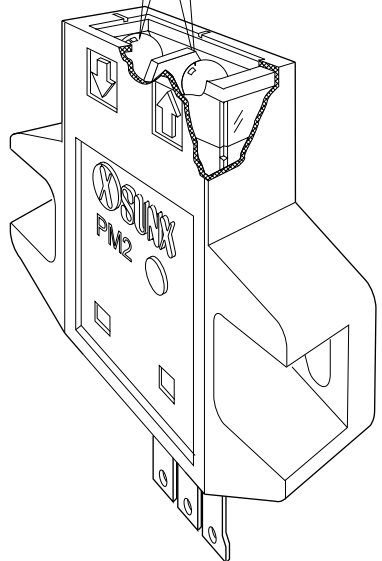
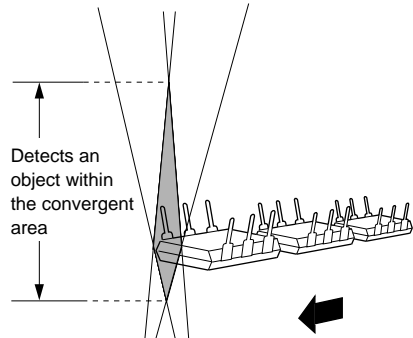

Not Affected by Background

Even a specular background does not affect the sensing performance if the sensor is located 30mm away from it (when directly opposite).

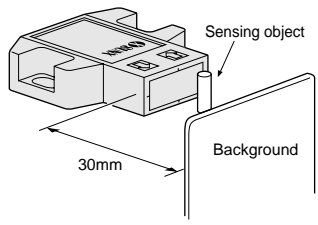

Dark Object Detectable

Since the sensor is very sensitive, it can detect even a dark object of low reflectivity.

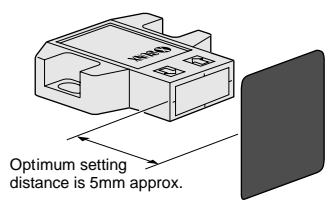

Minute Object Detectable

A $\phi 0.05\text{mm}$ copper wire can be detected at a distance of 5mm.

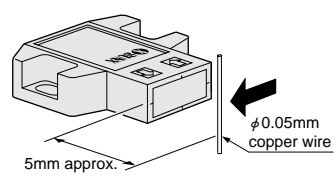

Cable Type is also Available

Cumbersome soldering is not required. It saves space and improves reliability.

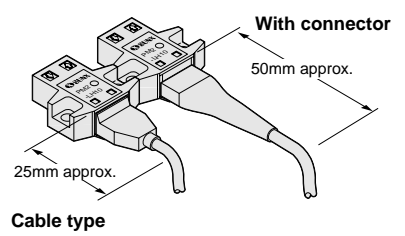

APPLICATIONS

Sensing capacitors in a tray

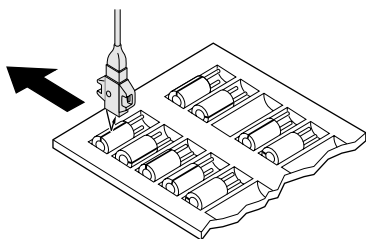

Sensing printed circuit boards

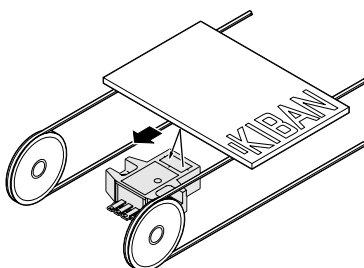

ORDER GUIDE

Type	Appearance	Sensing range	Model No.	Output operation
Connector type	Top sensing 	2.5 to 8mm (Convergent point: 5mm)	PM2-LH10	Light-ON
			PM2-LH10B	Dark-ON
	Front sensing 		PM2-LF10	Light-ON
			PM2-LF10B	Dark-ON
	L type (Top sensing) 		PM2-LL10	Light-ON
			PM2-LL10B	Dark-ON
Cable type	Top sensing 	PM2-LH10-C1	Light-ON	
		PM2-LH10B-C1	Dark-ON	
	Front sensing 	PM2-LF10-C1	Light-ON	
		PM2-LF10B-C1	Dark-ON	
	L type (Top sensing) 	PM2-LL10-C1	Light-ON	
		PM2-LL10B-C1	Dark-ON	

OPTIONS

Designation	Model No.	Description
Connector	CN-13	Dedicated connector
Mating cable	CN-13-C1	0.2mm ² 3-core cabtyre cable, 1m long
	CN-13-C3	0.2mm ² 3-core cabtyre cable, 3m long

Connector

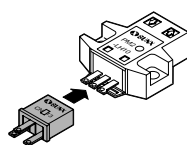

Mating cable

- CN-13-C1
- CN-13-C3

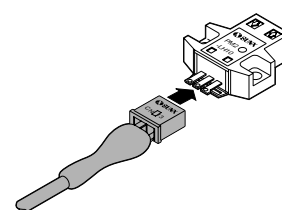

PM2

SPECIFICATIONS

Item	Model No.	Type	Connector type			Cable type		
			Top sensing	Front sensing	L type (Top sensing)	Top sensing	Front sensing	L type (Top sensing)
			Light-ON	PM2-LH10	PM2-LF10	PM2-LL10	PM2-LH10-C1	PM2-LF10-C1
		Dark-ON	PM2-LH10B	PM2-LF10B	PM2-LL10B	PM2-LH10B-C1	PM2-LF10B-C1	PM2-LL10B-C1
Sensing range			2.5 to 8mm (Conv. point: 5mm) with white non-glossy paper (15 × 15mm) (Note 1)					
Min. sensing object			φ0.05mm copper wire (Setting distance: 5mm)					
Hysteresis			20% or less of operation distance with white non-glossy paper (15 × 15 mm)					
Repeatability (pendicular to sensing axis)			0.08mm (Note 2)					
Supply voltage			5 to 24V DC ± 10% Ripple P-P 5% or less					
Current consumption			Average: 25mA or less, Peak: 80mA or less					
Output			NPN open-collector transistor <ul style="list-style-type: none"> • Maximum sink current: 100mA • Applied voltage: 30V DC or less (between output and 0V) • Residual voltage: 1V or less (at 100mA sink current) 0.4V or less (at 16mA sink current) 					
Utilization category			DC-12 or DC-13					
Short-circuit protection			Incorporated					
Response time			0.8ms or less					
Operation indicator			Red LED (lights up when the output is ON)					
Environmental resistance	Pollution degree		3 (Industrial environment)					
	Ambient temperature		- 10 to + 55°C (No dew condensation or icing allowed), Storage: - 25 to + 80°C					
	Ambient humidity		45 to 85% RH, Storage: 45 to 85% RH					
	Ambient illuminance		Sunlight: 11,000ℓx at the light-receiving face, Incandescent light: 3,500ℓx at the light-receiving face					
	EMC		Emission: EN50081-2, Immunity: EN50082-2					
	Vibration resistance		10 to 55Hz frequency, 1.5mm amplitude in X, Y and Z directions for two hours each					
	Shock resistance		500m/s ² acceleration (50G approx.) in X, Y and Z directions for three times each					
Emitting element			Infrared LED (modulated)					
Material			Enclosure: Polycarbonate, Terminal part: HSM (Ag plated)			Enclosure: Polycarbonate, Fixed cable part: PBT		
Cable						0.2mm ² 3-core cabtyre cable, 1m long (Note 3)		
Cable extension			Extension up to total 2m is possible with 0.3mm ² , or more, cable. (If the cable is extended for 2m, or more, a capacitor of 10μF must be connected between + V and 0V terminals.)					
Weight			4.5g approx.		4g approx.		25g approx.	

- Notes: 1) The sensing range may extend up to 12.5mm with white non-glossy paper due to product variation.
 2) The repeatability is specified for white non-glossy paper (15 × 15mm) at a setting distance of 5mm.
 3) Cable cannot be extended.

I/O CIRCUIT AND WIRING DIAGRAMS

I/O circuit diagram

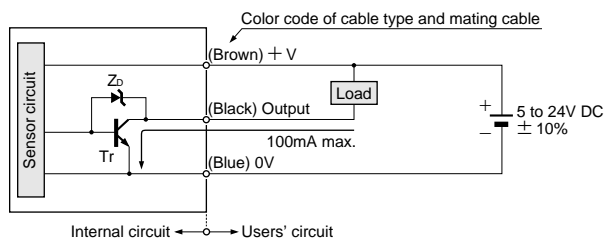

Wiring diagram

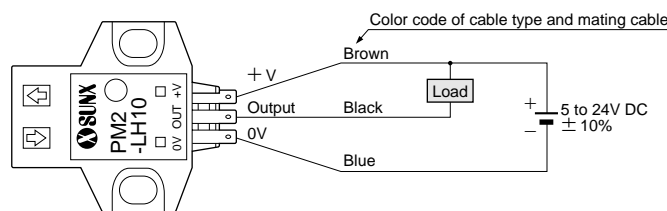

Symbols ... Zd: Surge absorption zener diode
Tr: NPN output transistor

SENSING CHARACTERISTICS (TYPICAL)

Sensing fields

• Horizontal (left and right) direction

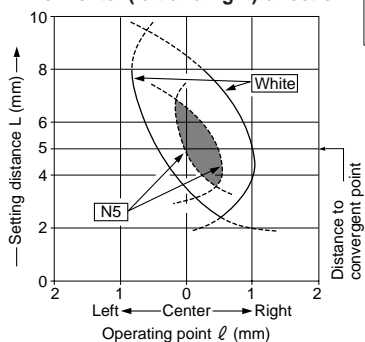

The sensors can be mounted side by side.

Horizontal direction

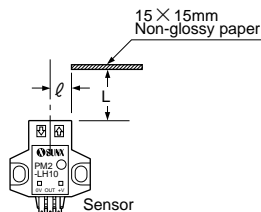

• Vertical (up and down) direction

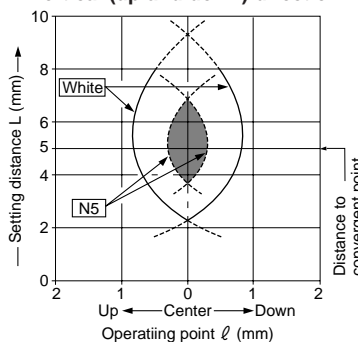

The sensors can be mounted side by side.

Vertical direction

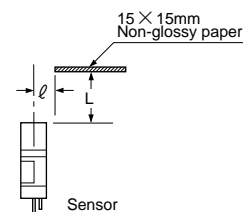

Correlation between lightness and sensing range

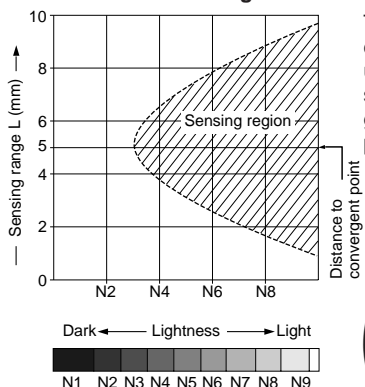

The sensing region is represented by oblique lines in the left figure. However, the sensitivity should be set with enough margin because of slight variation in products.

(Lightness shown on the left) may differ slightly from the actual object condition.

Correlation between material (15x15mm) and sensing range

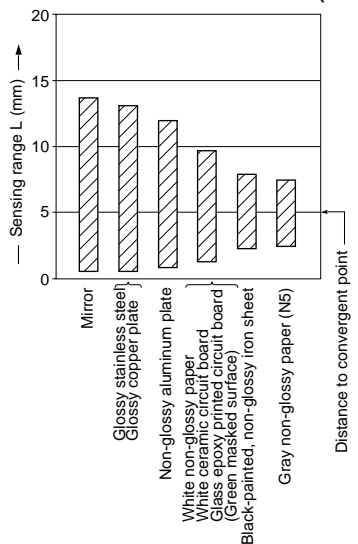

The bars in the graph indicate the sensing range for the respective material. However, there is a slight variation in the sensing range depending on the product. Further, if there is a reflective object (conveyor, etc.) in the background of the sensing object, since it affects the sensing, separate it by more than twice the sensing range shown in the left graph.

Sensor Mounting Stand
MS-AJ

Micro
PM

PM2

Multi-voltage Type
NX5

VF

Amplifier-separated Type
SU-7/SH

SS-A5

Sensor Checker
CHX-SC2

PRECAUTIONS FOR PROPER USE

Refer to P.820~ for general precautions.

All models



This product is not a safety sensor. Its use is not intended or designed to protect life and prevent body injury or property damage from dangerous parts of machinery. It is a normal object detection sensor.

Mounting

- When fixing the sensor with screws, use M3 screws and the tightening torque should be 0.49 N·m or less. Further, use small, round type plain washers ($\phi 6\text{mm}$).

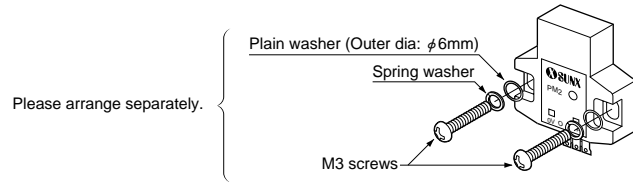

Wiring

- Make sure to connect terminals correctly as the sensor does not incorporate a reverse polarity protection circuit.
- If the sensor is being used in a noisy environment, examine the extent of noise. Further, if equipment, such as motor, solenoid or electromagnetic valve, which generates a large surge, is present near the sensor, connect a surge absorber to the equipment.

Setting

- The optimum setting distance (distance to convergent point) is 5mm. The sensor is not affected even by a specular background if it is located 30mm, or more, away from the sensor (when directly opposite).

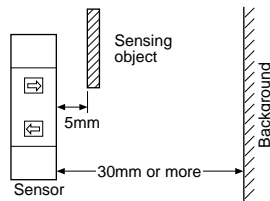

Others

- Do not use during the initial transient time (50ms) after the power supply is switched on.
- Take care that the product does not come in direct contact with oil, grease, or organic solvents, such as, thinner, etc.

Connector type

Soldering

- Solder the terminals under the following conditions.

Soldering temperature	260°C or less
Soldering time	10 sec. or less
Soldering position	Refer to the figure on the right

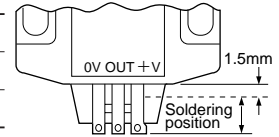

Wiring

- The cable length must be 2m, or less, with 0.3mm^2 , or more, cable. If the cable is extended for more than 2m, connect a capacitor of $10\mu\text{F}$ approx. between +V and 0V terminals.

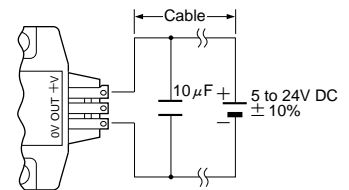
MS-AJ
Sensor Mounting StandPM
Micro

PM2

NX5

VF
Multi-voltage TypeSU-7/SH
Amplifier-separated TypeSS-A5
Amplifier-separated TypeCHX-SC2
Sensor Checker

DIMENSIONS (Unit: mm)

PM2-LH10
PM2-LH10B Sensor

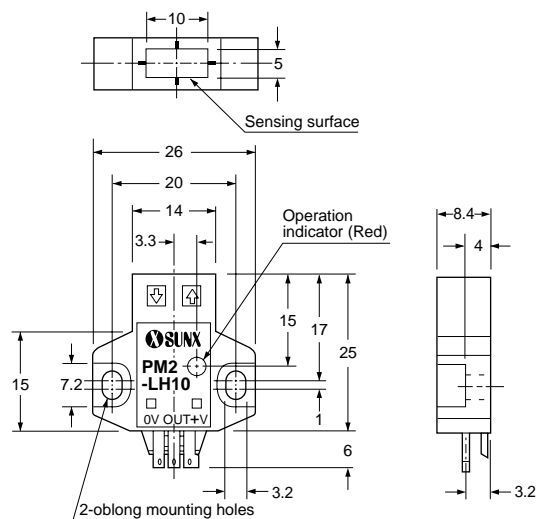

PM2-LF10
PM2-LF10B Sensor

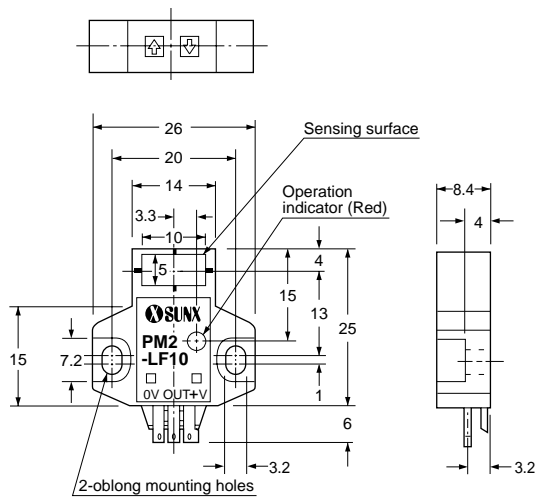

PM2-LL10
PM2-LL10B Sensor

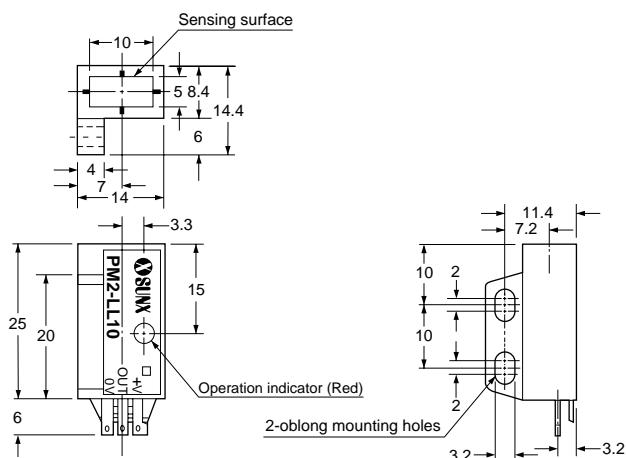

※ Terminal part (Connector type)

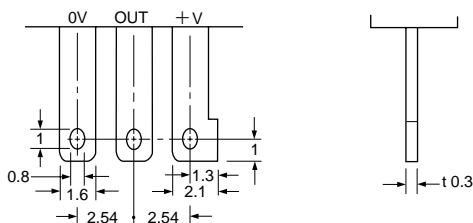

CN-13 Connector

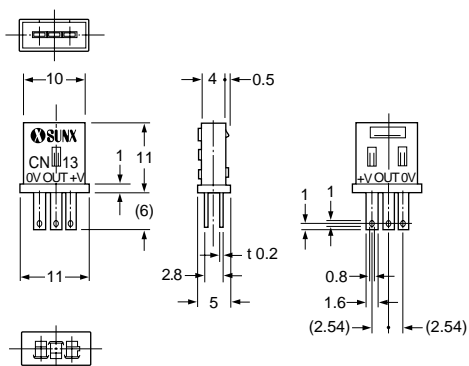

Sensor Mounting Stand
MS-AJ

Micro
PM2

Multi-voltage Type
NX5

VF

Amplifier-separated Type
SU-7/SH

SS-A5

Sensor Checker
CHX-SC2

PM2

DIMENSIONS (Unit: mm)

PM2-LH10-C1
PM2-LH10B-C1 Sensor

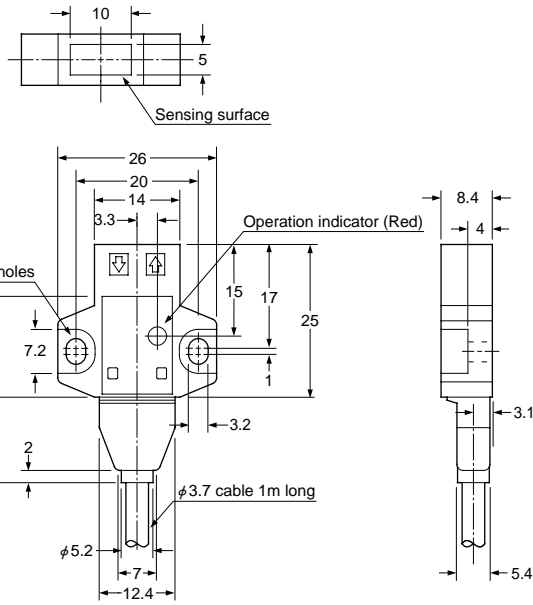

PM2-LF10-C1
PM2-LF10B-C1 Sensor

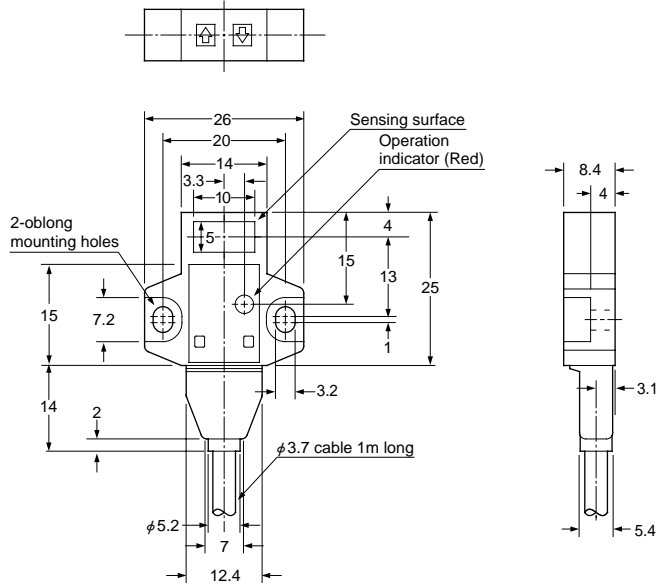

PM2-LL10-C1
PM2-LL10B-C1 Sensor

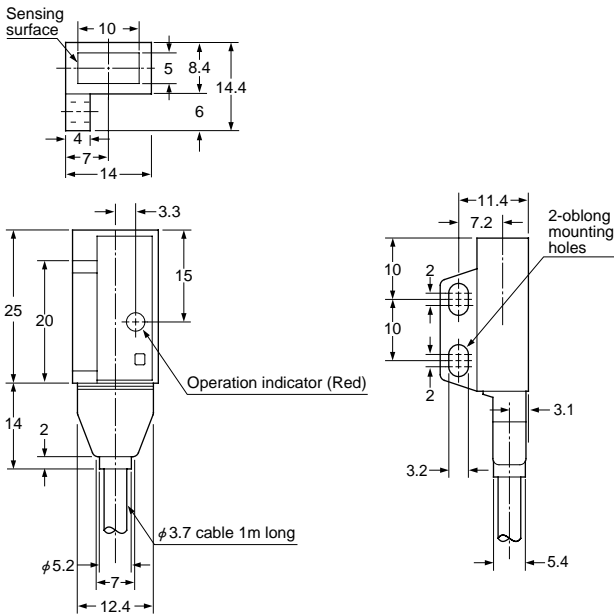

MS-AJ Sensor Mounting Stand
PM Micro
PM2
NX5 Multi-voltage Type
VF Multi-voltage Type
SU-7/SH Amplifier-separated Type
SS-A5 Amplifier-separated Type
CHX-SC2 Sensor Checker