

New SF-C14EX SERIES

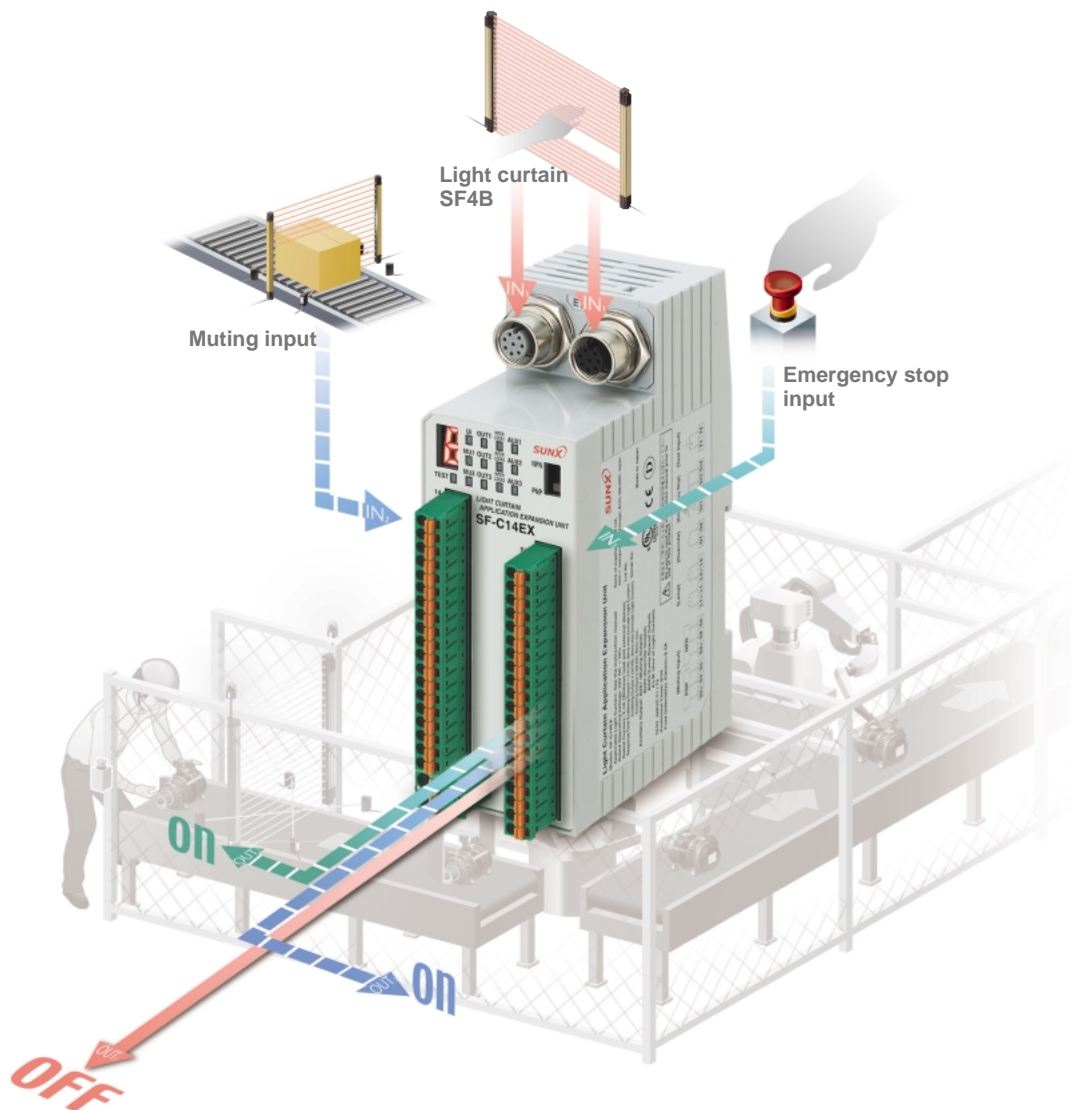

Expanding the possibilities for light curtains

Muting & Emergency stop & Semi-conductor output



Built-in muting control circuit. Light curtain and emergency stops can be controlled independently to achieve partial equipment stoppages.

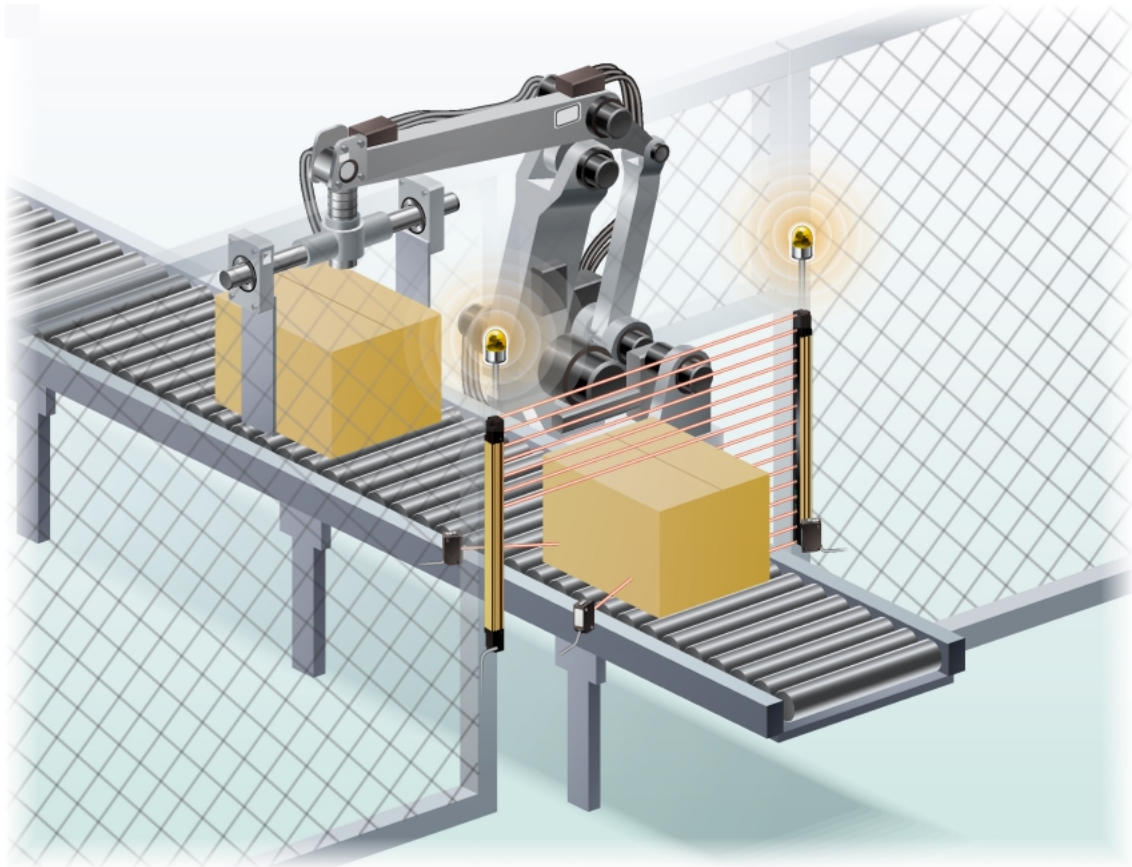

Building of muting control circuits is easy

The method used to build the safety circuit is selectable

When the **SF4B** series of light curtains is used, the muting control circuit can be built at low cost. The newly-released **SF-C14EX** application expansion unit allows the light curtain, muting sensors and muting indicators to be connected together directly, so that muting control circuits can be built very easily.

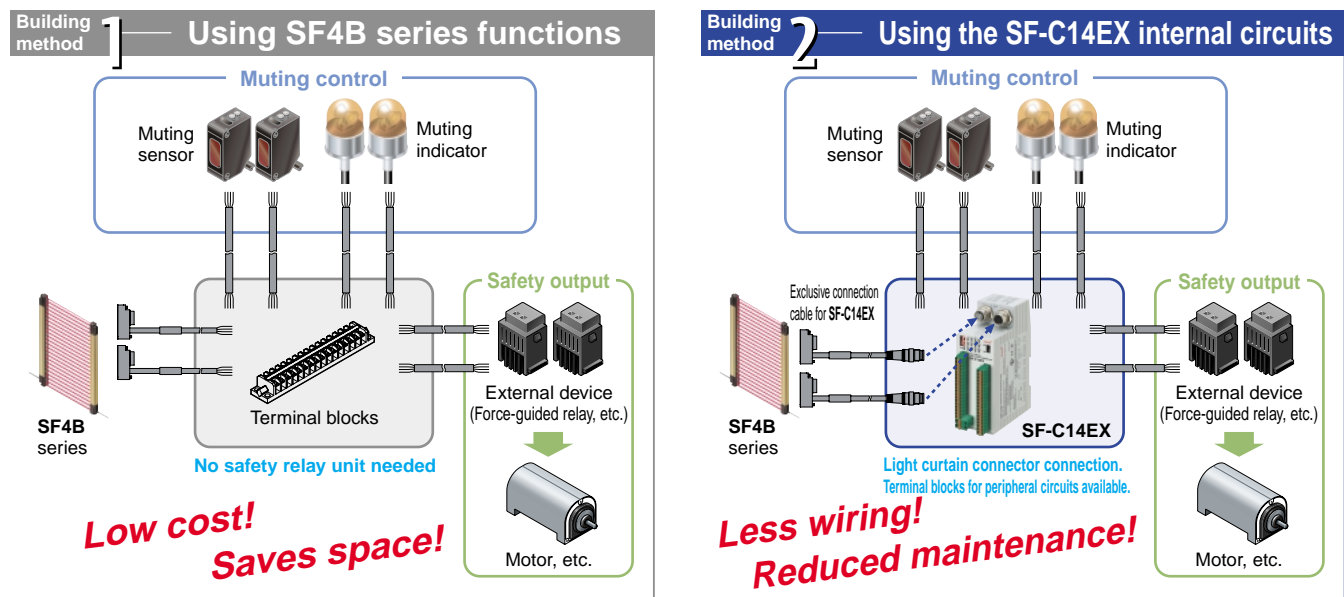

Applications expanded even further! Three safety circuit systems can be controlled independently so that equipment can be stopped all together or partially.

Motors that use muting control and those that do not use it can be controlled independently!

Controls the motors that use muting control (robots) and the motors that do not use muting control (turntables) with a single unit.

When the workpiece comes in, the turntable can be stopped and the robot can keep operating condition, to protect the safety of the operator and to maintain productivity.

Safety circuit ① : Linked to light curtain beam received / interrupted status (partial stop)

- When the light curtain is interrupted (when a workpiece enters or a person intrudes), this circuit switches off (open) the safety output and stops the turntable.

Safety circuit ② : Linked to muting control (partial stop)

- If a workpiece enters when the turntable has stopped normally (muting conditions are achieved), this circuit allows the robot to operate.
- If a workpiece enters while the turntable is turning (muting conditions are not achieved), this circuit switches off (open) the safety output and stops the robot.

Safety circuit ③ : Linked to emergency stop input (all stop)

- When the emergency stop button is pressed, this circuit switches off (open) the safety output and stops all equipment (turntable and robot).

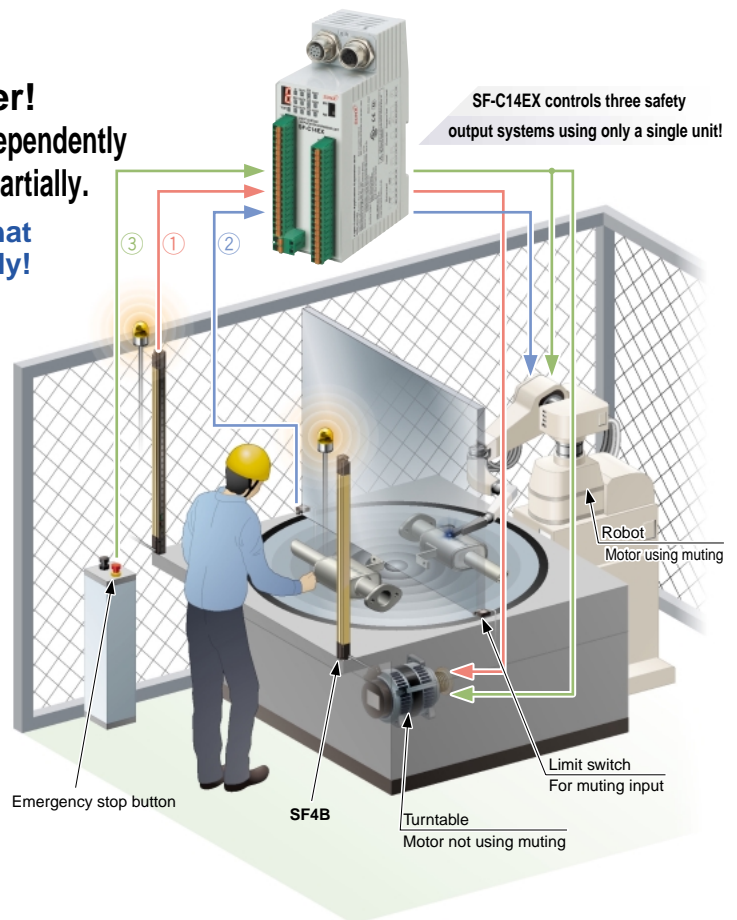

Three safety circuit systems packaged into a single unit!

Three safety circuit systems ① Light curtain output circuit, ② Muting control circuit, and ③ Emergency stop circuit are packaged into a single unit. Functions that require multiple safety relay units and muting control units can be concentrated into a single unit, which results in large space savings, less wiring and less installation work.

High-speed response 14 ms (Including light curtain)

Avoids the response delays that occur when using more than one safety relay unit, and greatly reduces the light curtain safety distance and improves ease of working.

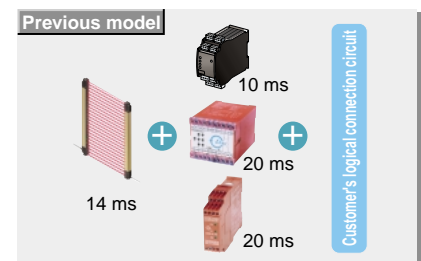
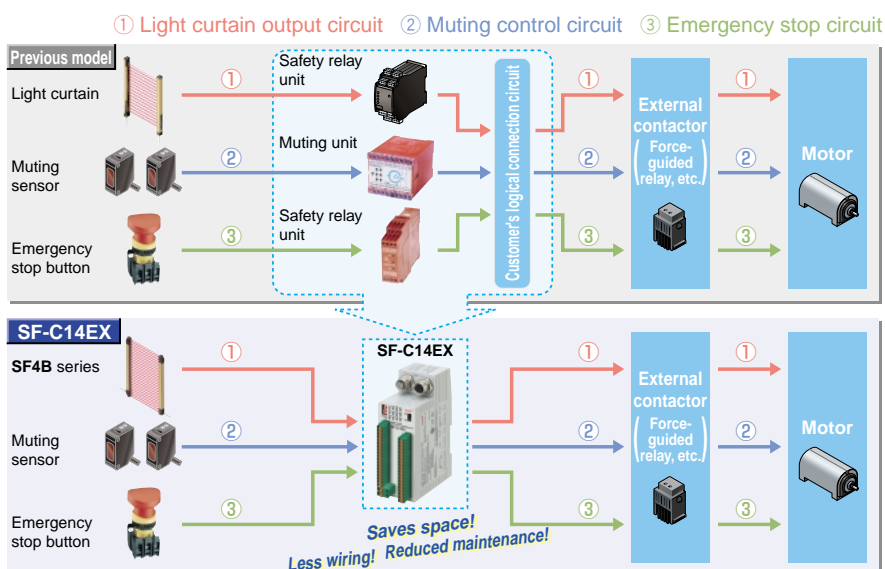

Detailed functions that support easier 'installation' and 'maintenance'

Semiconductor output reduces running costs!

Semiconductor output is used for safety output. This means there is no need to periodically replace safety relays.

Adoption of semiconductor output

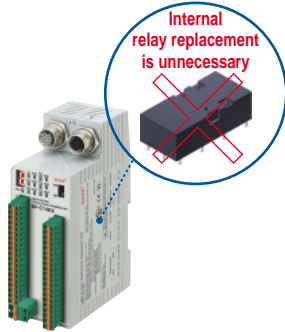

Equipped with a digital indicator so that error details can be understood at a glance!

If a problem should occur, the same output (OFF signal) as when the object was detected is maintained in order to ensure safety, and the details of the error appear on the digital display.

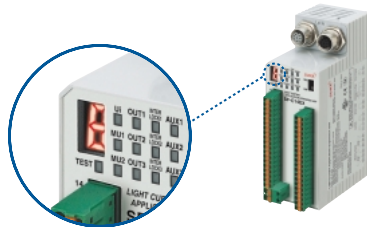

Equipped with blown lamp output for muting indicator

If a lamp in one of the two muting indicators that are connected to the unit blows, a warning is output. It is possible to replace the lamp before both lamps blow and the equipment stops. In addition, auxiliary output that is linked to the muting function, override function and light curtain control output is also available.

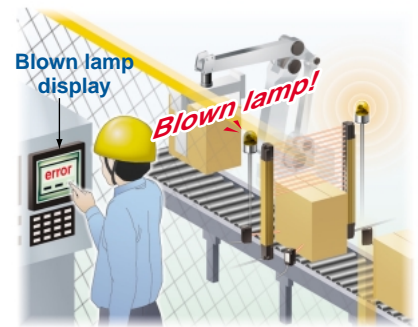

Supports both PNP and NPN polarities

A single model can be used for PNP / NPN input switching, reducing the number of parts that need to be registered.

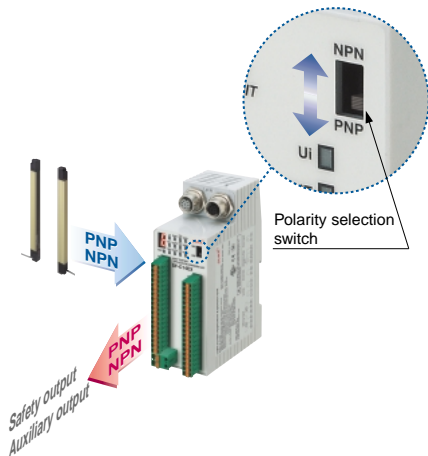

Removable terminal blocks reduce maintenance time

Removable terminal blocks are used. This reduces the work required for reconnecting wiring during maintenance.



Easy setup requiring no torque control

A spring method is used for the terminal blocks for connections other than to the light curtain. There is no need to control tightening torques for these terminal blocks.

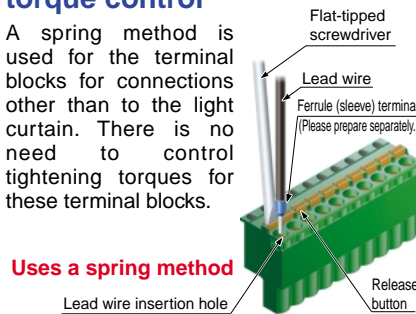

Uses a spring method

	Function	Operation
Auxiliary output 1	Muting output	ON when the muting function is invalid
Auxiliary output 2	Override output	ON when the override function is invalid
Auxiliary output 3	Blown lamp output	ON when the muting indicator is normal
Auxiliary output 4	Light curtain auxiliary output	ON when the light curtain is in light interrupted condition

Compatible with a Handy-controller for easy setting

SF-C14EX only

Can be used to set a wide variety of functions together with the SFB-HC Handy-controller

• Separate muting control function for each beam channel

The SFB-HC Handy-Controller (optional) can be used to carry out muting control for specified beam channels only.

• Any valid beam channels can be selected! The SF4B series incorporates a fixed blanking function

The SF4B series is equipped with a fixed blanking function that allows specific beam channels to be selectively blocked, without causing the control output (OSSD) to output the OFF signal.

• Non-specified beam channels can be deactivated !

The SF4B series incorporates a floating blanking function
1, 2 or 3 non-specified beam channels can be deactivated.

• Auxiliary output has selectable output configuration

The output configuration of the auxiliary output can be changed.

During muting control (line moving)

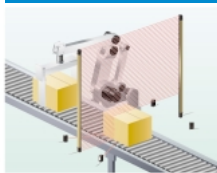

Line stopped



For example, if muting control is set to be carried out in accordance with the height of the workpiece, the machinery stops when any of the beam channels are interrupted above the workpiece.

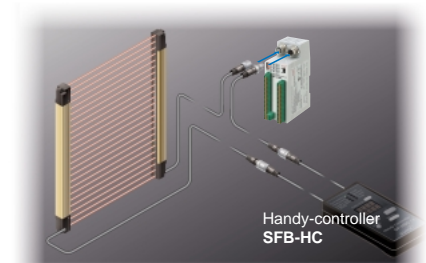

* A Handy-controller cannot be used with the SF-C14EX-01.

A variety of other functions can be selected

- Emission intensity control function
- Setting monitoring function
- Protection function
- Copy function
- Muting indicator diagnosis setting

ORDER GUIDE

Application expansion unit

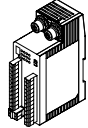
Appearance	Model No.	Description
	SF-C14EX	Up to control category 4

Handy-controller non-compatible type

A type that cannot have its functions (refer to p.3) set using the **SFB-HC** Handy-controller (optional) is also available.
Model No.: **SF-C14EX-01**

Light curtains connection cable

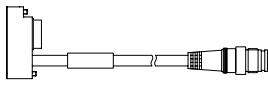
Type	Appearance	Model No.	Description
Exclusive connection cable for SF-C14EX		SFB-CB05-EX	Length: 0.5 m 1.640 ft Net weight: 95 g approx. (2 cables)
		SFB-CB5-EX	Length: 5 m 16.404 ft Net weight: 620 g approx. (2 cables)
		SFB-CB10-EX	Length: 10 m 32.808 ft Net weight: 1,200 g approx. (1 cable)

Note: If extending cables between light curtain units, be sure to use the **SFB-CCJ10E** (for emitter; cable length 10 m **32.808 ft**) and the **SFB-CCJ10D** (for receiver; cable length 10 m **32.808 ft**). The cable can be extended within 30 m **98.425 ft** (for emitter / receiver) when two light curtains are connected with series connection, within 20 m **65.617 ft** when three light curtains are connected with series connection. The cables cannot be extended when connecting in parallel.

SPECIFICATIONS

Item	Model No.	SF-C14EX
Connectable light curtain		SF4B series
Applicable standard		IEC 61496-1, UL 61496-1, EN 61496-1, JIS B 9704-1
Control category		Applicable to Category 4 based on ISO 13849-1 (EN 954-1, JIS B 9705-1)
Supply voltage		24 V DC $\pm 10\%$ Ripple P-P 10% or less
Current consumption		0.2 A or less (Excluding light curtain and other external connecting device)
Safety output (Safety output 1 Safety output 2 Safety output 3)		PNP open collector transistor 2 outputs $\times 3$ or NPN open collector transistor 2 outputs $\times 3$ (selectable using a slider switch) <When PNP output is selected> <ul style="list-style-type: none"> • Maximum source current: 200 mA or less • Applied voltage: same as supply voltage (between the safety output and + V) • Residual voltage: 2 V or less (at 200 mA source current) <When NPN output is selected> <ul style="list-style-type: none"> • Maximum sink current: 200 mA or less • Applied voltage: same as supply voltage (between the safety output and 0 V) • Residual voltage: 2 V or less (at 200 mA sink current)
Operation mode (Output operation)		Safety output 1: ON when the light curtain is in light receiving condition, OFF when the light curtain is in light interrupted condition (Note 2) Safety output 2: ON when the light curtain is in light receiving condition or the muting function is valid OFF when the light curtain is in light interrupted condition and the muting function is invalid (Note 2) Safety output 3: ON when the emergency stop is invalid, OFF when the emergency stop is valid
Protection circuit (Short-circuit protection)		Incorporated
Response time		OFF response: 14 ms or less (Safety output 1 and 2: including the response time of the light curtain) ON response: 90 ms or less (auto-reset) / 140 ms or less (manual reset) (Note 3)
Auxiliary output (Auxiliary output 1 Auxiliary output 2 Auxiliary output 3 Auxiliary output 4 (Note 4))		PNP open collector transistor $\times 3$ or NPN open collector transistor $\times 3$ (selectable using a slider switch) <When PNP output is selected> <ul style="list-style-type: none"> • Maximum source current: 60 mA or less • Applied voltage: same as supply voltage (between the auxiliary output and + V) • Residual voltage: 2 V or less (at 60 mA source current) <When NPN output is selected> <ul style="list-style-type: none"> • Maximum sink current: 60 mA or less • Applied voltage: same as supply voltage (between the auxiliary output and 0 V) • Residual voltage: 2 V or less (at 60 mA sink current)
Operation mode (Output operation)		Auxiliary output 1: ON when the muting function is invalid, OFF when the muting function is valid Auxiliary output 2: ON when the override function is invalid, OFF when the override function is valid Auxiliary output 3: ON when the muting indicator is normal, OFF when the muting indicator is error Auxiliary output 4: ON when the light curtain is in light interrupted condition, OFF when the light curtain is in light receiving condition (Note 4)
Protection circuit (Short-circuit protection)		Incorporated
Muting indicator output		Applicable muting indicator: 24 V DC, 3.6 to 30 W (per unit)
Protection circuit (Short-circuit protection)		Incorporated
Protection		Enclosure: IP40, Terminal: IP20
Ambient temperature / Ambient humidity		- 10 to + 55 °C + 14 to + 131 °F (No dew condensation or icing allowed), Storage: - 25 to + 70 °C - 13 to + 158 °F / 30 to 85 % RH, Storage: 30 to 95 % RH
Dielectric strength voltage / Insulation resistance		1,000 V AC for one min. between all supply terminals connected together and enclosure / 20 M Ω , or more, with 500 V DC megger between all supply terminals connected together and enclosure
Vibration resistance / Shock resistance		10 to 55 Hz frequency, 0.35 mm 0.014 in amplitude in X, Y and Z directions for two hours each (in power OFF state) / 30 G acceleration in X, Y and Z directions for three times each (in power OFF state)
Material		Enclosure: ABS
Connection terminal		Detachable spring gauge terminal
Weight		Net weight: 250 g approx.

Notes: 1) Where measurement conditions have not been specified precisely, the conditions used were ambient temperature + 20 °C **+ 68 °F**.
2) Both safety output 1 and 2 are OFF when the emergency stop is valid regardless of whether the light curtain is in the light receiving or light interrupted condition.
3) The auto-reset cannot be used with safety output 3.
4) The auxiliary output incorporated in the SF4B is available at the SF4B's enclosure de la malle - 51270 Saint Brice Courcelles
Tel : 03.26.04.20.21 - Fax : 03.26.04.28.20 - Web : <http://www.audin.fr> - Email : info@audin.fr

WIRING DIAGRAM

SF4B series wiring diagram

For PNP output (minus ground)

- Set the light curtain output polarity selection switch to the PNP side and ground the 0 V line.

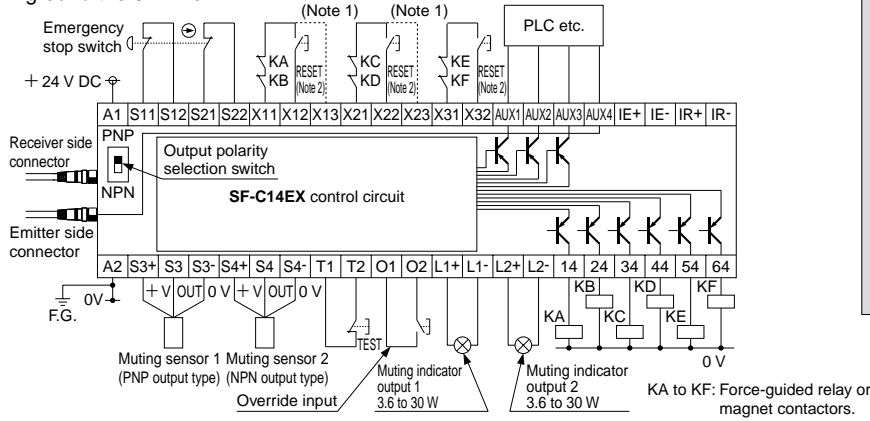

- Notes: 1) The above diagram is for manual reset. If using automatic reset, move X12 to X13 and move X22 to X23 as shown by the dotted lines. In this case, the RESET button is not required. Terminals X31 to X32 are for manual reset only.
2) Use a momentary-type switch for the RESET button.

For NPN output (plus ground)

- Set the light curtain output polarity selection switch to the NPN side and ground the + side of the power supply input.

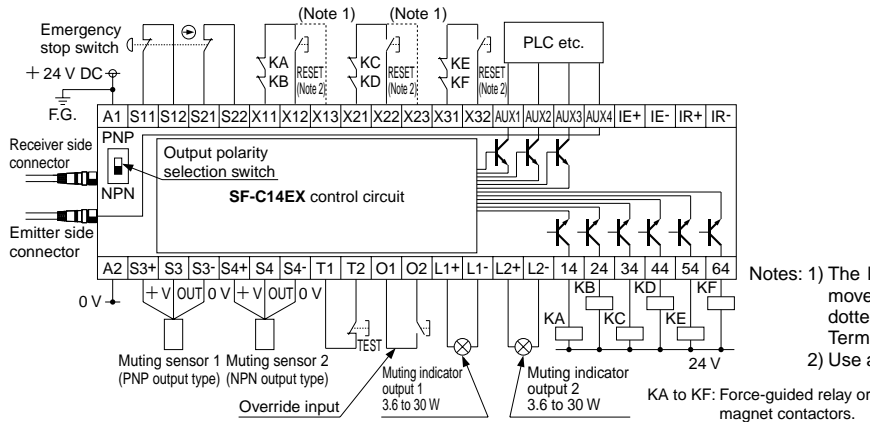

- Notes: 1) The left diagram is for manual reset. If using automatic reset, move X12 to X13 and move X22 to X23 as shown by the dotted lines. In this case, the RESET button is not required. Terminals X31 to X32 are for manual reset only.
2) Use a momentary-type switch for the RESET button.

- When this product is connected to the light curtain, be sure to use the following connecting cable.
 - SFB-CB05-EX** (Cable length 0.5 m 1.640 ft)
 - SFB-CB5-EX** (Cable length 5 m 16.404 ft)
 - SFB-CB10-EX** (Cable length 10 m 32.808 ft)
- If the NO (Normally Open) contact switch is used as a muting sensor, wire it as shown in the figure below.
- If the emergency stop switch is not used, short-circuit between the terminals S11 to S12 and S21 to S22 directly.

Terminal arrangement diagram

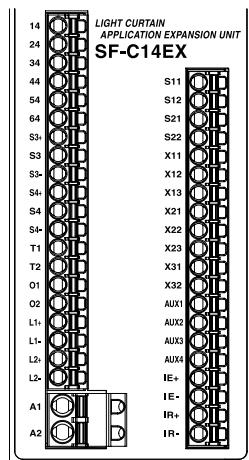

Terminal	Function	Terminal	Function
14	Safety output 1, Light received / Light interrupted output of the light curtain	S11	Emergency stop contact input
24		S12	2 NC input
34	Safety output 2, Light curtain output including the muting function	S21	Between S11 and S12
44		S22	Between S21 and S22
54	Safety output 3	X11	Safety output 1 reset input
64	Emergency stop output	X12	X11 - X12: Manual reset
S3+	Muting sensor input 1 (PNP output type)	X13	X11 - X13: Auto-reset
S3-	S3 +, S3 - : Power supply, S3: Sensor output	X21	Safety output 2 reset input
S4+	Muting sensor input 2 (NPN output type)	X22	X21 - X22: Manual reset
S4-	S4 +, S4 - : Power supply, S4: Sensor output	X23	X21 - X23: Auto-reset
T1	Test input terminal	X31	Safety output 3 reset input
T2	Open: Test mode, Short-circuit: Normal operation	X32	X31 - X32: Manual reset
O1	Override input terminal	AUX1	Auxiliary output 1, Muting output
O2	Open: Invalid, Short-circuit: Valid	AUX2	Auxiliary output 2, Override output
L1+	Muting indicator output 1	AUX3	Auxiliary output 3, Blown lamp output
L1-		AUX4	Auxiliary output 4, Light curtain auxiliary output
L2+	Muting indicator output 2	IE+	Interference prevention terminal, Emitter side +
L2-		IE-	Interference prevention terminal, Emitter side -
A1	+ 24 V DC	IR+	Interference prevention terminal, Receiver side +
A2	0 V	IR-	Interference prevention terminal, Receiver side -

PRECAUTIONS FOR PROPER USE

Part description and function

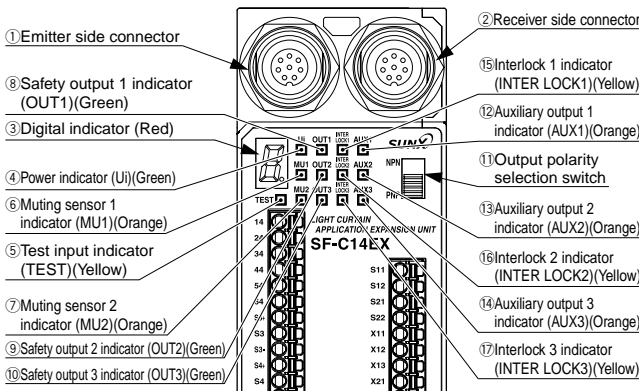

No.	Description	Function
①	Emitter side connector	The emitter of SF4B series is connected.
②	Receiver side connector	The receiver of SF4B series is connected.
③	Digital indicator (Red)	Lights up or blinks when there is a problem. Lights up when blanking function is enabled.
④	Power indicator (Ui) (Green)	Lights up when power is supplied.
⑤	Test input indicator (TEST) (Yellow)	Lights up when test input is enabled. Blinks while communication with SFB-HC handy-controller is in progress.
⑥	Muting sensor 1 indicator (MU1) (Orange)	Lights up when muting sensor 1 is ON.
⑦	Muting sensor 2 indicator (MU2) (Orange)	Lights up when muting sensor 2 is ON.
⑧	Safety output 1 indicator (OUT1) (Green)	Lights up when safety output 1 is ON.
⑨	Safety output 2 indicator (OUT2) (Green)	Lights up when safety output 2 is ON.
⑩	Safety output 3 indicator (OUT3) (Green)	Lights up when safety output 3 is ON.
⑪	Output polarity selection switch	PNP (minus ground) or NPN (plus ground) can be selected. The factory setting is PNP (minus ground).
⑫	Auxiliary output 1 indicator (AUX1) (Orange)	Lights up when auxiliary output 1 is ON.
⑬	Auxiliary output 2 indicator (AUX2) (Orange)	Lights up when auxiliary output 2 is ON.
⑭	Auxiliary output 3 indicator (AUX3) (Orange)	Lights up when auxiliary output 3 is ON.
⑮	Interlock 1 indicator (INTER LOCK1) (Yellow)	Lights up when interlock 1 is ON.
⑯	Interlock 2 indicator (INTER LOCK2) (Yellow)	Lights up when interlock 2 is ON.
⑰	Interlock 3 indicator (INTER LOCK3) (Yellow)	Lights up when interlock 3 is ON.

Wiring

- The following solid wire and twisted wires (lead wire) are recommended.

Power supply line connectors (A1 and A2): 0.2 to 2.5 mm² (AWG24 to AWG12)
 Other connectors: 0.2 to 1.5 mm² (AWG24 to AWG16)

Output waveform (Safety output ON)

- When safety output is ON, self-diagnosis of the output circuit is carried out, so that the output transistor will periodically turn OFF. (OFF pulse width: 100 μs or less)
 When the OFF signal is fed back, the receiver judges the output circuit as normal. When the OFF signal is not fed back, the receiver judges either the output circuit or wiring as error, and the safety output maintains OFF status.

Since the OFF signal of this device might cause malfunction, perform the connecting paying attention to the input response time of the machine to be connected to this device.

Others

- When connecting this product to a product other than the connectable input device, the system does not conform to the control category 4 based on ISO 13849-1 (EN 954-1, JIS B 9705-1).
- Connect this product and the output line to the same power supply.
- The power supply unit of this equipment uses the electronic fuse which does not require any replacement.
- When the electronic fuse trips, turn off the power supply and eliminate the cause for the overcurrent. After that, turn the power back on.
- The electronic fuse is not meant to be used for equipment that is operated continuously. Note that the specification may not be satisfied by continuous operation.
- Make sure to carry out the wiring in the power supply off condition.
- Wrong wiring will damage the product.
- Verify that the supply voltage variation is within the rating. Note that if a voltage exceeding the rated range is applied, or if an AC power supply is directly connected, the unit may get burnt or damaged.
- The DC power supply unit must satisfy the conditions given below:
 - Power supply unit authorized in the region where this device is to be used.
 - Power supply unit conforming to EMC Directive and Low-voltage Directive (In case CE conformity is required.)
 - Power supply unit conforming to the Low-voltage Directive and with an output of 100 VA or less.
 - The frame ground (F.G.) terminal must be connected to ground when using a commercially available switching regulator.
 - Power supply unit with an output holding time of 20 ms or more.
 - Use an isolation transformer for the DC power supply unit.
 - If surges are likely to occur, take countermeasures such as connecting a surge absorber to the origin of the surge.
 - Power supply unit corresponding to CLASS 2 (In case UL / c UL conformity is required.)

<Additional information>
 As provided in IEC 60536 (CLASS: Protection against Electric Shock), this power supply should require no ground earth and satisfy the insulation distance by double insulation or reinforced insulation.
 (If the power supply conforms to Low-voltage Directive and has an output of 100 VA or less, it can be used as a suitable product.)
- Do not run the wires together with high-voltage lines or power lines or put them in the same raceway. This can cause malfunction due to induction.
- This product is not dust-proof / splash proof. Be sure to put this product into a control box having IP54 construction.
- Avoid dust, dirt and steam.
- Take care that the product does not come in direct contact with oil, grease, or organic solvents, such as, thinner, etc.
- Note that this equipment is applicable only in the control circuit grounded in accordance with IEC 60204-1 and JIS B 9960-1, or in the control circuit in which the insulation monitor unit (ground fault detection unit) is included.
- This unit is suitable for indoor use only.
- The seal as shown in the drawing on the below is stuck to the engagement point of unit. If the seal is peeled off or broken, this equipment will not be certified as 'Safety equipment' and will not be covered by our guarantee.

Do not open!
 If this seal is removed or damaged,
 the units are not recognized as safety product.
SUNX Ltd.

PRECAUTIONS FOR PROPER USE

Time chart

Normal operation The diagram shows operation with safety outputs 1 and 2 in manual-reset mode.

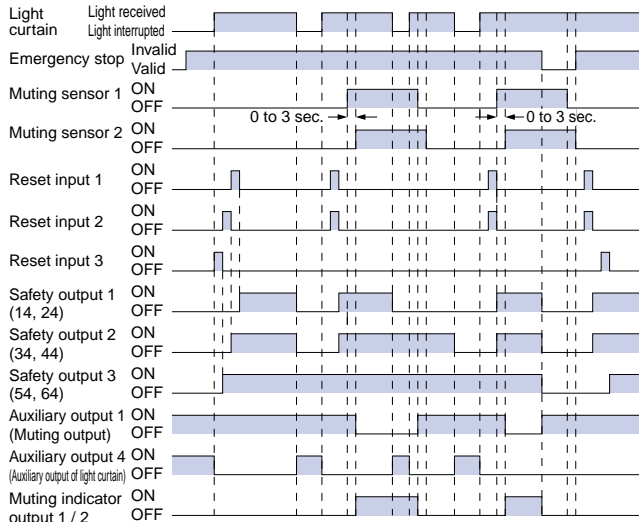

- The diagram above is the timing chart of this product in normal operation.
- In normal operation, auxiliary output 2 (override output) is maintained in the ON state.
- In normal operation, auxiliary output 3 (muting indicator output) is maintained in the ON state.

Test input, Override input The diagram shows operation with safety outputs 1 and 2 in auto-reset mode.

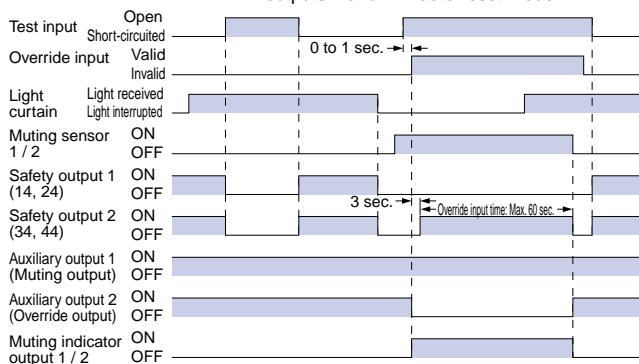

- Safety outputs 1 and 2 are OFF during test input.
- The override function becomes valid when all the conditions listed below are satisfied:
 - An incandescent lamp with 3.6 to 30 W is at least connected to either muting indicator output 1 or 2.
 - The signal is input to either muting sensor A or B.
 - The override input terminal T1 / T2 is short-circuited and the test input terminal T1 / T2 is opened within 1 sec. (3 sec. continuously)
- If one of the three conditions above becomes invalid or the timing exceeds 60 sec., the override function becomes invalid.

All information is subject to change without prior notice.

Blown lamp output The diagram shows operation with safety outputs 1 and 2 in auto-reset mode.

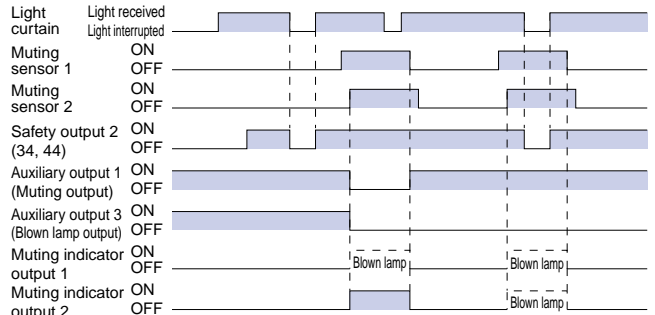

- The lamps are monitored during muting state, and if either of them breaks, auxiliary output 3 is turned OFF. If only one lamp breaks, the muting state is maintained, however, if both lamps break, the muting state is canceled immediately.

DIMENSIONS (Unit: mm in)

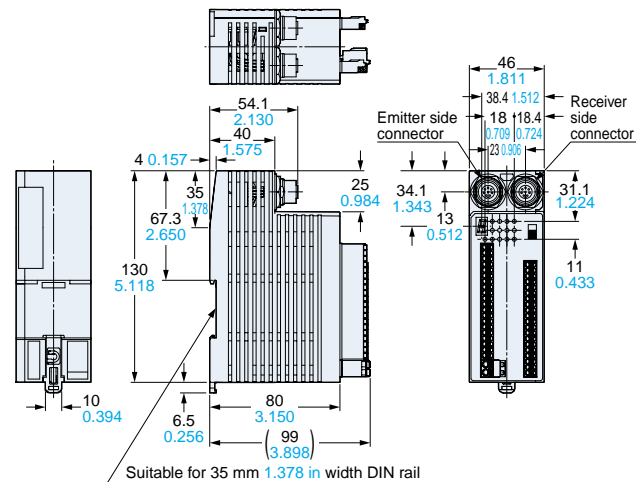

SUNX Limited

2431-1 Ushiyama-cho, Kasugai-shi, Aichi,
486-0901, Japan
Phone: +81-(0)568-33-7211
FAX: +81-(0)568-33-2631

Overseas Sales Dept.

Phone: +81-(0)568-33-7861
FAX: +81-(0)568-33-8591

<http://www.sunx.co.jp/>