

DOORS & GATES

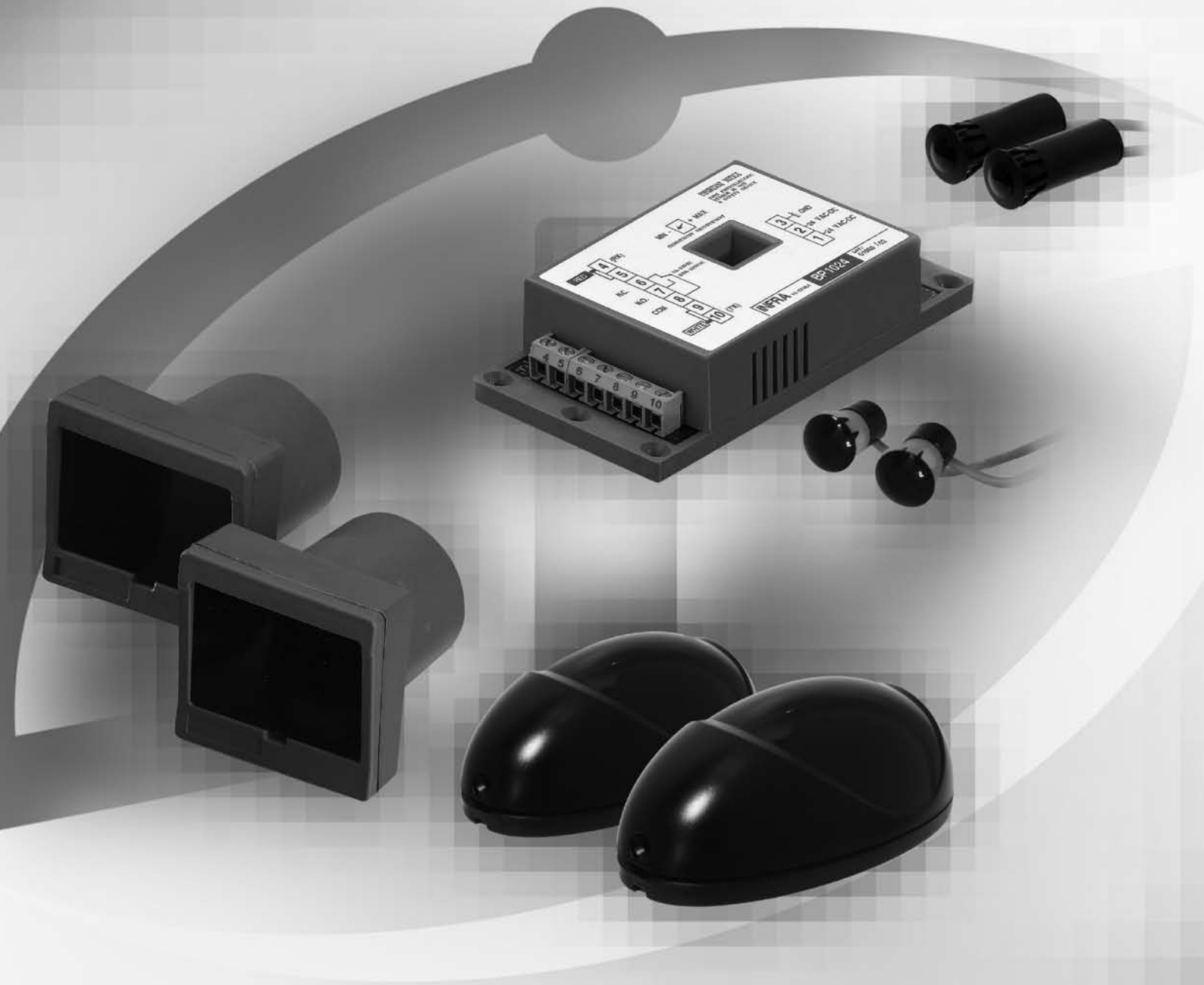

iNFRA

THRU BEAM PHOTOELECTRIC SENSORS



FOR ELEVATORS AND AUTOMATIC DOORS

10÷30 V DC - NPN/PNP NO/NC OUTPUT

- Snap in emitter and receiver
- Fully amplified stand alone unit
- Selectable switching distance (6 or 12m)
- NPN/PNP NO/NC output
- Conforming to EN 12978 and EN 954-1

BP Series



IDENTIFICATION CODE

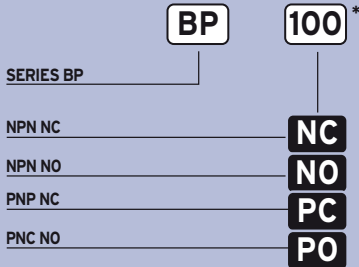

* One Beam 10 ÷ 30 V DC, TX + RX.

AVAILABLE	RECEIVER	EMITTER
NOMINAL SWITCHING DISTANCE (Sn)	6 ÷ 12 m (Selectable with different wiring)	
TOLERANCE	+10/-10%Sn	
EMISSION	Infrared (875nm)	
NOMINAL VOLTAGE	10 ÷ 30 VDC (-15/+10%)	
MAX. CURRENT OUTPUT	100 mA	
ABSORPTION	2.5 mA	20 mA
YELLOW LED	not present	
GREEN LED	not present	
SWITCHING FREQUENCY	100Hz	
START UP DELAY	≤200ms	
TEMPERATURE LIMITS	-20°C +60°C	
LIGHT IMMUNITY	> 50.000 Lux	
PROTECTION DEGREE	IP67	
CONNECTIONS	Black PVC Cable	Grey PVC Cable
CABLE LENGTH	5m	
CABLE SECTION	3 x 0.14 mm ²	
HOUSING MATERIAL	Body: ABS - Lenses: PMMA	
WEIGHT (Approximately)	75g	

(1) Determined with halogen tungsten lamp 3000 °K

WIRING DIAGRAMS

EMITTER

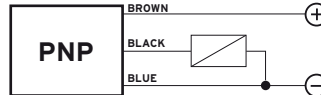
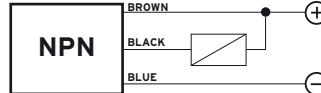

RECEIVER

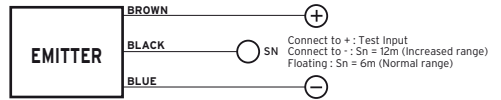

DIMENSIONS (mm)

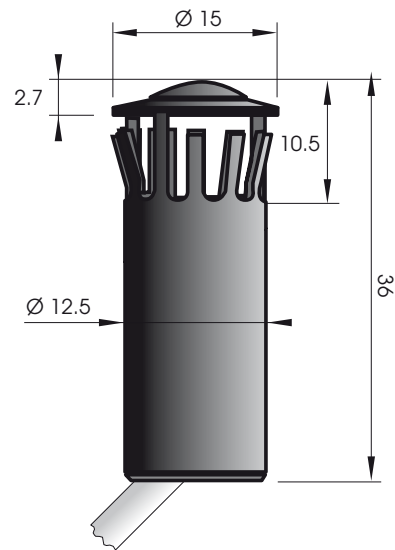

CHARACTERISTICS CURVE

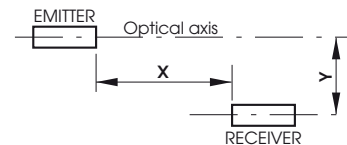
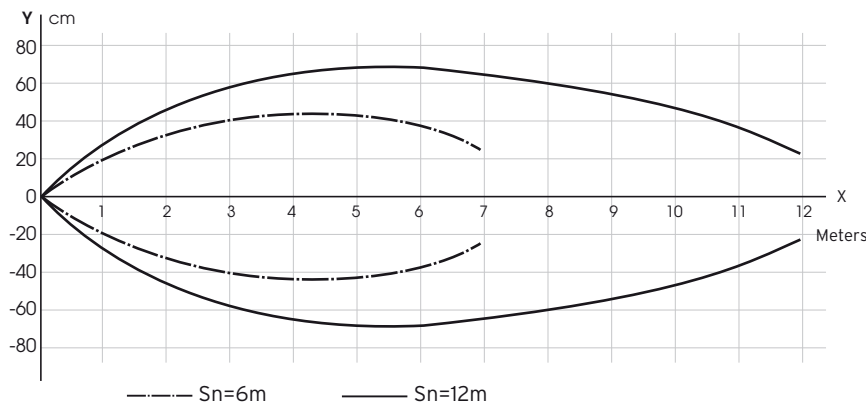

DOORS

THRU BEAM PHOTOELECTRIC SENSORS FOR ELEVATORS AND AUTOMATIC DOORS RELAY OUTPUT



- With separate amplifier
- 12-24 AC/DC input
- Conforming to EN 12978
- 1A relay SPDT
- Sensitivity adjustment
- 6 m long integral cables

BP Series



IDENTIFICATION CODE

BP **10**

SERIES BP

ONE BEAM 12÷24 VAC/DC

Note: Each package includes a pair of projectors.

AVAILABLE	ONE BEAM SELECTION
NOMINAL SWITCHING DISTANCE (Sn)	10 m
TOLERANCE	+10/-10 %Sn
EMISSION	Infrared (875 nm)
NOMINAL VOLTAGE	12 ÷ 24 VAC DC (-15 / +10%)
FREQUENCY	50 ÷ 60 Hz
OUTPUT	2 Relay
N° OF OPERATIONS	(5x10 ⁶ mec. op. -3x10 ⁵ elect. op.)
MAX OUTPUT CURRENT	1A 24 VDC - 0.5A 120 VAC
ABSORPTION	70 mA
YELLOW LED	Output and activated thru beam indicator
GREEN LED	Supply indicator
SENSITIVITY ADJUSTMENT	Present
SWITCHING FREQUENCY	5 Hz
RESPONSE TIME	100 ms
START UP DELAY	≤ 300 ms
TEMPERATURE LIMITS	-20 ÷ +60°C
LIGHT IMMUNITY	5000 Lux ⁽¹⁾
PROTECTION DEGREE Amplifiers	IP 50
PROTECTION DEGREE Projectors	IP 65
CONNECTIONS	with connectors
HOUSING MATERIAL Amplifiers	ABS
HOUSING MATERIAL Projectors	Body - Lenses: methacrylate
WEIGHT (Approximately)	300 g

⁽¹⁾ Determined with halogen tungsten lamp 3000 °K.

WIRING DIAGRAMS

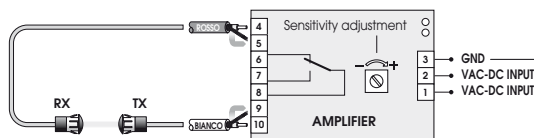

AMPLIFIER DIMENSIONS (mm)

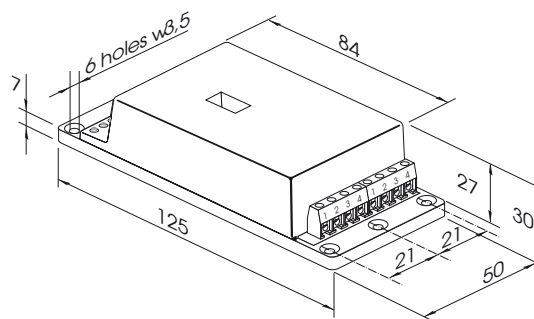

PROJECTOR DIMENSIONS (mm)

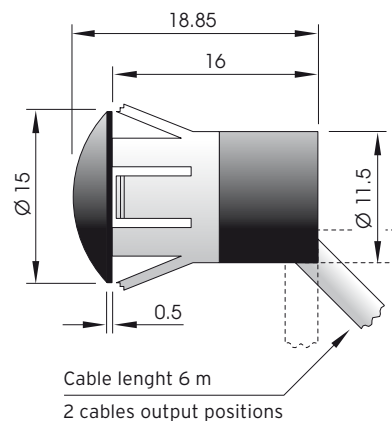

IMPORTANT WARNING

The thru beam photoelectric sensor can be used as a sensor to detect the presence of an obstacle if the sensing beam gets interrupted. In no case this device can substituted the obligatory safety devices that must be applied on all dangerous equipments.

CHARACTERISTICS CURVE

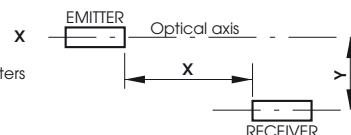
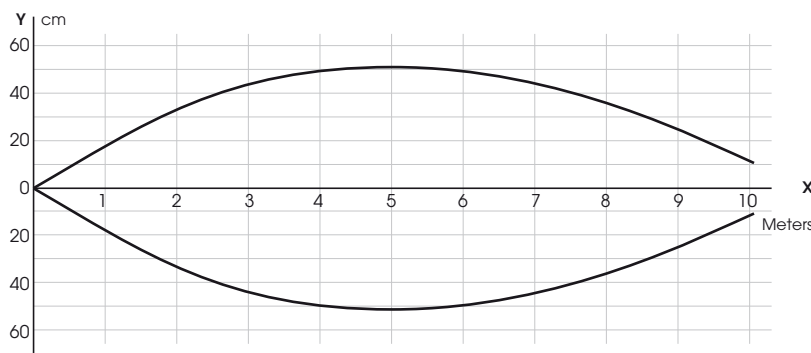

THRU BEAM PHOTOELECTRIC SENSORS FOR ELEVATORS AND AUTOMATIC DOORS RELAY OUTPUT



BP Series



- With separate amplifier
- 230 V AC input
- 5 Hz frequency/response
- 8 A relay SPDT
- Sensitivity adjustment
- 6 m long integral cables

IDENTIFICATION CODE

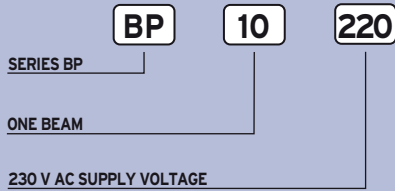

Note: Each package includes a pair of projectors.

AVAILABLE	ONE BEAM SELECTION
NOMINAL SWITCHING DISTANCE (Sn)	10 m
TOLERANCE	+10/-10 %Sn
EMISSION	Infrared (875 nm)
NOMINAL VOLTAGE	230 V AC (-15 / +10%)
FREQUENCY	50 ÷ 60 Hz
OUTPUT	Relay
N° OF OPERATIONS	Relay (5x10 ⁷ mec. op. -1x10 ⁵ elect. op.)
MAX OUTPUT CURRENT	8A 250 VAC
ABSORPTION	17 mA
YELLOW LED	Output and activated thru beam indicator
GREEN LED	Supply indicator
SENSITIVITY ADJUSTMENT	Present
SWITCHING FREQUENCY	5 Hz
RESPONSE TIME	100 ms
START UP DELAY	≤ 300 ms
TEMPERATURE LIMITS	-20 ÷ +60°C
LIGHT IMMUNITY	5000 Lux ⁽¹⁾
PROTECTION DEGREE Amplifiers	IP 50
PROTECTION DEGREE Projectors	IP 65
CONNECTIONS	with connectors
HOUSING MATERIAL Amplifiers	ABS
HOUSING MATERIAL Projectors	Body - Lenses: methacrylate
WEIGHT (Approximately)	350 g

⁽¹⁾ Determined with halogen tungsten lamp 3000 °K.

WIRING DIAGRAMS

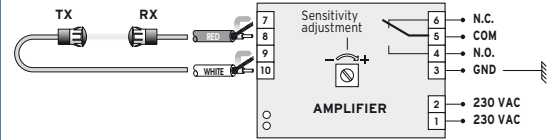

AMPLIFIER DIMENSIONS (mm)

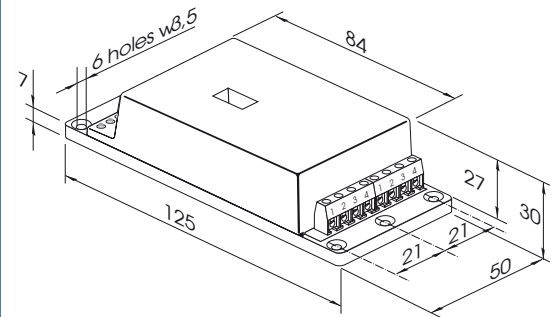

PROJECTOR DIMENSIONS (mm)

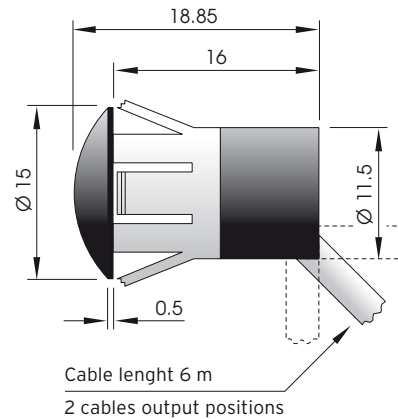

IMPORTANT WARNING

The thru beam photoelectric sensor can be used as a sensor to detect the presence of an obstacle if the sensing beam gets interrupted. In no case this device can substituted the obligatory safety devices that must be applied on all dangerous equipments.

CHARACTERISTICS CURVE

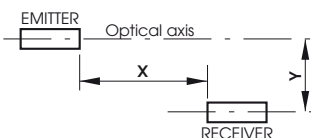
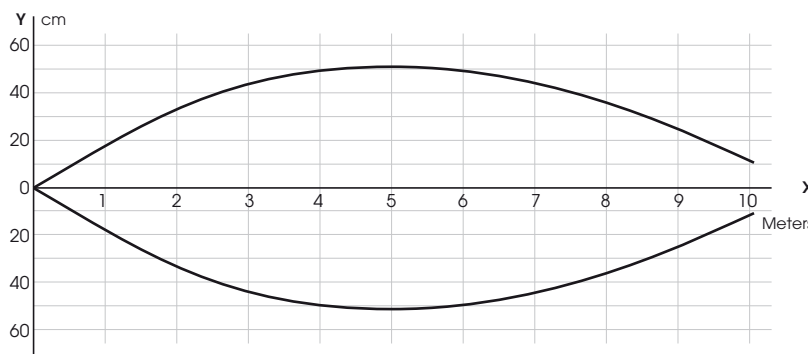

DOORS

THRU BEAM PHOTOELECTRIC SENSORS FOR ELEVATORS AND AUTOMATIC DOORS WITH TIME RELAY OUTPUT DOUBLE BEAM



BP Series



- Single or dual channel
- Conforming to EN 12978
- 1 sec OFF delay timer, selectable
- 12-24 V AC/DC input
- Sensitivity adjustment
- 6 m long integral cables

IDENTIFICATION CODE

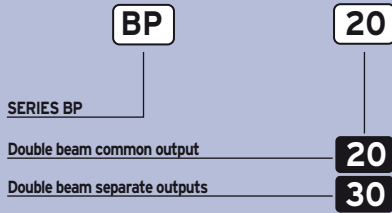

Note: Each package includes a pair of projectors.

AVAILABLE	DOUBLE BEAM SELECTION
NOMINAL SWITCHING DISTANCE (Sn)	0.3 ÷ 10 m
TOLERANCE	+10/-10 %Sn
EMISSION	Infrared (875 nm)
NOMINAL VOLTAGE	12 ÷ 24 V AC DC ± (-15 / +10%)
FREQUENCY	50 ÷ 60 Hz
OUTPUT	2 Relay
N° OF OPERATIONS	Mec. = 5x10 ⁶ ops min. - Elect. = 3x10 ⁸ ops min; (1A 28VDC) 1x10 ⁸ ops min. (0.5A 120VAC)
MAX OUTPUT CURRENT	1A 28 VDC - 0.5A 120 VAC (28W 60V A)
ABSORPTION	80 mA
YELLOW LED	Output and activated thru beam indicator
GREEN LED	Supply indicator
SWITCHING FREQUENCY	5 Hz
START UP DELAY	≤ 300 ms
TEMPERATURE LIMITS	-20 ÷ +60°C
LIGHT IMMUNITY	> 5000 Lux ⁽¹⁾
PROTECTION DEGREE Amplifiers	IP 50
PROTECTION DEGREE Projectors	IP 65
CONNECTIONS	with connectors
HOUSING MATERIAL Amplifiers	ABS
HOUSING MATERIAL Projectors	Body - Lenses: methacrylate
WEIGHT (Approximately)	430 g

⁽¹⁾ Determined with halogen tungsten lamp 3000 °K.

IMPORTANT WARNING

The thru beam photoelectric sensor can be used as a sensor to detect the presence of an obstacle if the sensing beam gets interrupted. In no case this device can substituted the obligatory safety devices that must be applied on all dangerous equipments.

CHARACTERISTICS CURVE

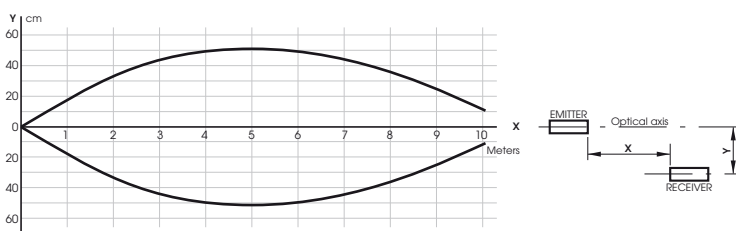

WIRING DIAGRAMS

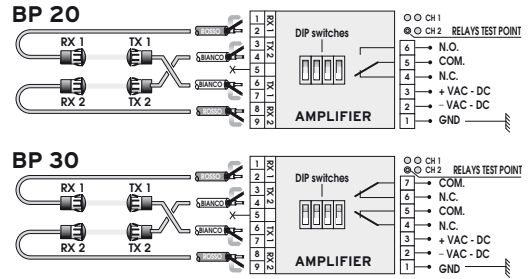

One beam selection

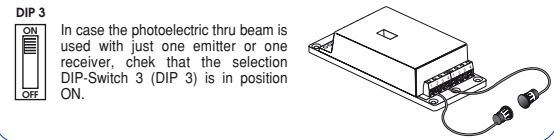

DOUBLE BEAM SELECTION

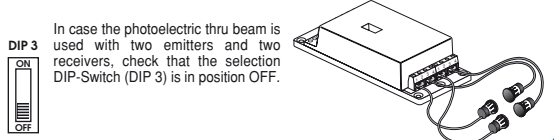

REDUCED WORKING DISTANCE (BP20 MOD.)

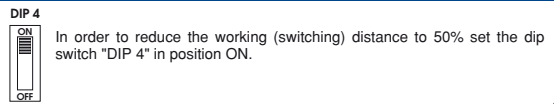

DELAY AT SENSOR DEACTIVATION

Operating on the suitable DIP-Switches it is possible to select on each channel a delay to the sensor deactivation, it permits to keep the sensor excited for about 1 second once the obstacle has passed the active area. Regulating the DIP-Switches (DIP 1 and DIP 2) in position ON, the delay is activated.

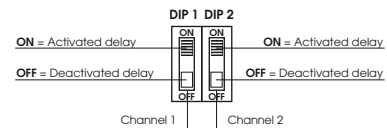

AMPLIFIER DIMENSIONS (mm)

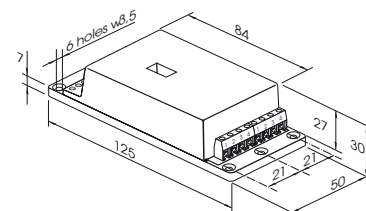

PROJECTOR DIMENSIONS (mm)

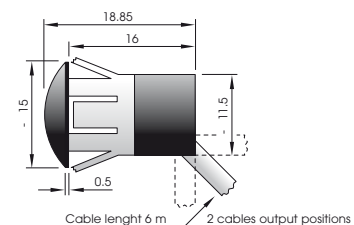



CROSS BEAMS LIGHT CURTAINS

FOR ELEVATORS AND AUTOMATIC DOORS WIDE RANGE OF SIZE UP TO 2m AND 94 CROSS BEAMS

- Selectable resolution from 30 mm up to 60 mm
- Protection degree IP65
- External control unit not needed
- Conform to EN81-70 - EN954-1 (cat. 2)

BPCX Series



IDENTIFICATION CODE

BPC X 1 A 04 A K ⁽³⁾ ⁽⁵⁾ ⁽⁶⁾

BPC SERIES

SELECTABLE VERSION

SOLID STATE OUTPUT 1 ⁽²⁾⁽³⁾

SOLID STATE + RELAY OUTPUT 3 ⁽²⁾⁽⁴⁾

RELAY OUTPUT 5 ⁽³⁾

PNP NO + NPN NC OUTPUT A

PNP NC + NPN NO OUTPUT B

4 LED (10 cross beams) 04

8 LED (22 cross beams) 08

12 LED (34 cross beams) 12

16 LED (46 cross beams) 16

24 LED (70 cross beams) 24

32 LED (94 cross beams) 32

h = 589 mm A

h = 1053 mm B

h = 1517 mm C

h = 1981 mm D

M8 CONNECTOR OUTPUT 4 WIRES (K2) K

- (2) A and B must be specified only for options 1 and 3.
 (3) Option 1 e 5 available only with M8 4 wires connector.
 (4) Option 3 available only with 5 m PUR cable.
 (5) When used with K connector output, max.tension ratings on the relay are 60 VAC or 75 VDC.
 (6) Connector versions are supplied with n. 2 K2F90V5R.

AVAILABLE	RECEIVER	EMITTER
NOMINAL SWITCHING DISTANCE (Sn)	4 m	
TOLERANCE	+10/-10%Sn	
HYSTERESIS	10%	
OPTICAL SYNCHRONISM	Present	
EMISSION	-	Infrared (875 nm)
NOMINAL VOLTAGE	12-24 V AC/DC (-15/+10%)	
RESIDUAL RIPPLE	10%	
OUTPUT	Relay (10 ⁸ ops. min.) or NPN+PNP	-
CONTACT	NO or NC	-
MAX. OUTPUT CURRENT	1A-30VDC MAX 220VDC (30WDC/62,5VAC) 200 mA (SOLID STATE)	-
ABSORPTION AT 30 V DC	70 mA	90 mA
VOLTAGE DROP (Sensor ON)	≤ 1,8V (I = 100mA)	-
RED LED	Output indicator	Test indicator
YELLOW LED	Supply indicator	
SENSITIVITY ADJUSTEMENT	-	Trimmer 1 turn
SWITCHING FREQUENCY	10 Hz	
RESPONSE TIME	See selection table	
START UP DELAY	3 sec	
SHORT CIRCUIT PROTECTION	Present (self resetting)	-
ELECTRIC PROTECTIONS	Against polarity reversal - inductive loads	
TEMPERATURE LIMITS	-10 ÷ +60 °C	
LIGHT IMMUNITY	> 10.000 Lux ⁽¹⁾	
PROTECTION DEGREE	IP 65	
CABLE LENGTH (only for option 3)	5 m Pur hight flex	
CABLE SECTION (only for option 3)	5 x 0,35 mm ²	4 x 0,35 mm ²
HOUSING MATERIAL	Aluminium	
WEIGHT APPROX.	0,5 m = 2 Kg - 1 m = 2,5 Kg - 1,5 m = 3 Kg - 2 m = 4 Kg	

(1) Determined with halogen tungsten lamp 3000 °K.

SELECTION TABLE

Order code	Relay	Solid state	Product L. mm	LED no.	Risp. time ms	Resolut. mm	Profile h. mm
BPCX 1 A 08 A K			589,00	08	25,00	30,00	561,50
1 B 08 A K							
3 A 08 A							
3 B 08 A							
5 08 A K							
BPCX 1 A 04 A K			1053,00	04	12,50	60,00	1025,50
1 B 04 A K							
3 A 04 A							
3 B 04 A							
5 04 A K							
BPCX 1 A 16 B K			1517,00	16	50,00	30,00	1489,50
1 B 16 B K							
3 A 16 B							
3 B 16 B							
5 16 B K							
BPCX 1 A 08 B K			1981,00	08	25,00	60,00	1953,50
1 B 08 B K							
3 A 08 B							
3 B 08 B							
5 08 B K							
BPCX 1 A 24 C K			1981,00	24	75,00	30,00	1953,50
1 B 24 C K							
3 A 24 C							
3 B 24 C							
5 24 C K							
BPCX 1 A 12 C K			1981,00	12	37,50	60,00	1953,50
1 B 12 C K							
3 A 12 C							
3 B 12 C							
5 12 C K							
BPCX 1 A 32 D K			1981,00	32	100,00	30,00	1953,50
1 B 32 D K							
3 A 32 D							
3 B 32 D							
5 32 D K							
BPCX 1 A 16 D K			1981,00	16	50,00	60,00	1953,50
1 B 16 D K							
3 A 16 D							
3 B 16 D							
5 16 D K							

EMITTER OPTION 3 WIRING DIAGRAMS

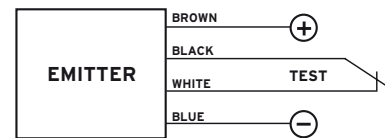

RECEIVER OPTION 3 SOLID STATE + RELAY OUTPUT

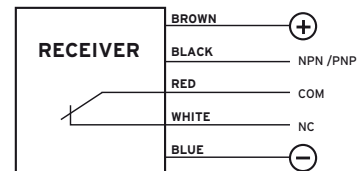

CHARACTERISTIC CURVES

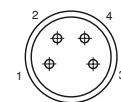

View of quadrupole male connector

CONTACTS CONFIGURATION

Output	Contacts numbers			
	1	2	3	4
EMITTER	+	TEST	-	TEST
OPTION 1 SOLID STATE OUTPUT	+	-	-	NPN/PNP
OPTION 5 RELAY OUTPUT	+	NC	-	COM

CROSS BEAMS LIGHT CURTAINS

FOR ELEVATORS AND AUTOMATIC DOORS

WIDE RANGE OF SIZE UP TO 2m AND 94 CROSS BEAMS

- Selectable resolution from 30 mm up to 60 mm
- Protection degree IP65
- External control unit not needed
- Conform to EN81-70 - EN954-1 (cat. 2)



BPCX Series



CHARACTERISTIC CURVES (mm)

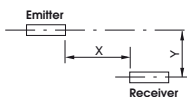
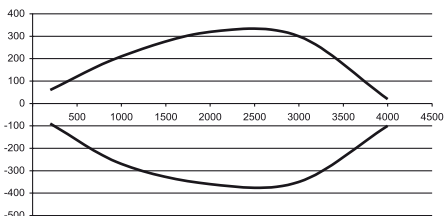

ALUMINIUM PROFILE SECTIONS

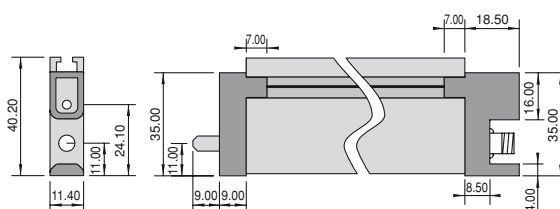

DIMENSIONS (mm)

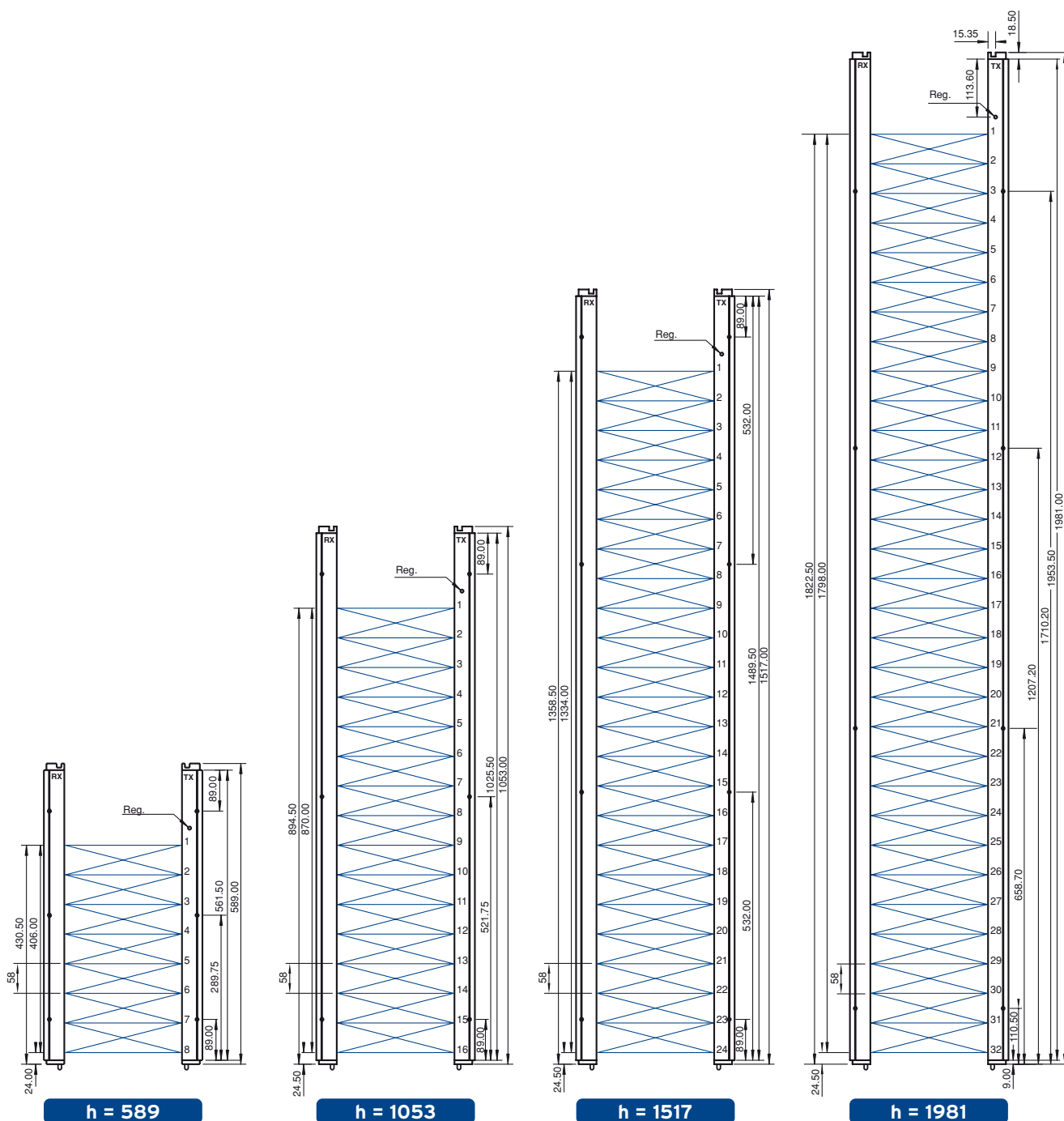

h = 589

h = 1053

h = 1517

h = 1981

Note: the drawings refer to the maximum resolution versions.

DOORS

PHOTOELECTRIC SENSORS



THRU BEAM

12÷30 V DC - NPN OR PNP OUTPUT

- 18mm tubular in metal housing
- Operation LED aids installation
- Cable or M12 quick connect models
- Emitter with test input

18 Series



IDENTIFICATION CODE

	18	22	K	T	*	EX ⁽²⁾
SERIES 18						
NPN NO output		22				
NPN NC output		23				
PNP NO output		24				
PNP NC output		25				
Emitter		21				
CONNECTOR OUTPUT M12						
TEST INPUT						
⊕ ATEX GROUP II CAT. 3D						

* Option valid only for code 1821

AVAILABLE	RECEIVER	EMITTER
NOMINAL SWITCHING DISTANCE (Sn)	25 m	
TOLERANCE	+10/-10 %Sn	
HYSTERESIS	10%	
EMISSION	-	Infrared (875 nm)
NOMINAL VOLTAGE	12 ÷ 30VDC (-15 /+10%)	
RESIDUAL RIPPLE	10%	
MAX. OUTPUT CURRENT	200 mA	-
ABSORPTION AT 30 VDC	15 mA	
VOLTAGE DROP (Sensor ON)	1.5V (I = 200 mA)	-
OPERATION LED	Yellow	
SWITCHING FREQUENCY	200 Hz	
RESPONSE TIME	2.5 ms	
START UP DELAY	100 ms	
SHORT CIRCUIT PROTECTION	Present (self-resetting)	
ELECTRIC PROTECTIONS	Against polarity reversal - inductive loads	
TEMPERATURE LIMITS	-10 ÷ +60 °C	
LIGHT IMMUNITY	> 10000 Lux ⁽¹⁾	
PROTECTION DEGREE	IP 67 (IP 65 for models with sensitivity adjustment)	
CABLE LENGTH	2 m	
CABLE SECTION	3 x 0.25 mm ²	3/2 x 0.25 mm ²
HOUSING MATERIAL	Housing: nickel plated brass - Lenses: methacrylate	
WEIGHT - cable output - (connector output)	- 110 g - (55 g)	

⁽¹⁾ Determined with halogen tungsten lamp 3000 °K.

⁽²⁾ Device marking ⊕ II 3D IP67 T6X.

Note: for a proper use see norms at pages 18, 19, 20, 21 and 22.

WIRING DIAGRAMS

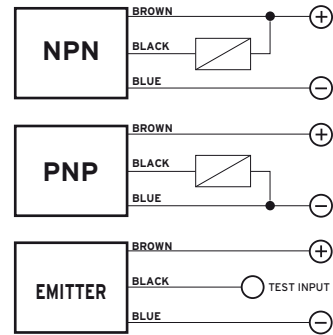

CONNECTION WITH CONNECTOR M12 (K)

View of quadripole male connector.

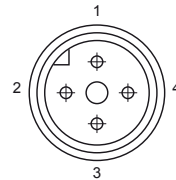

CONTACTS CONFIGURATION

Available	Contacts numbers			
	1	2	3	4
(NO o NC)	+		-	NO/NC
Emitter	+		-	TEST

ACCESSORIES

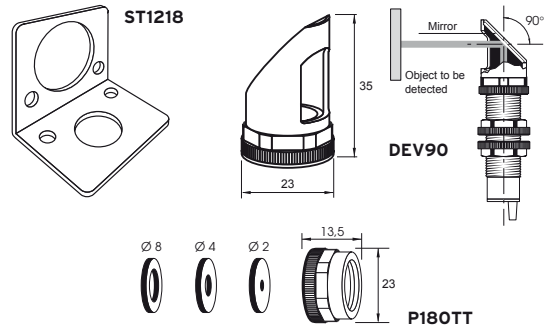

DIMENSIONS (mm)

Configuration with cable

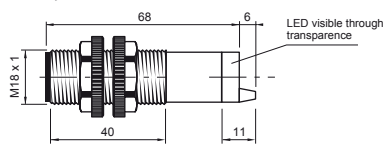

Configuration with cable - Back view

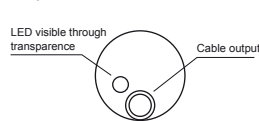

Configuration with connector K

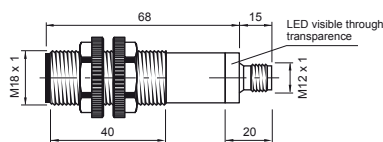

Configuration with connector K Back view

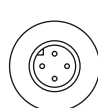

CHARACTERISTIC CURVES

THRU BEAM
Distance X (m)

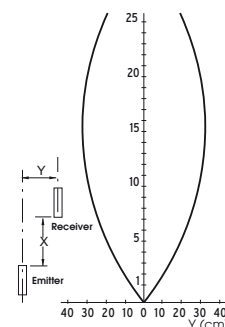

Copyright © 2000 Infra Srl. All rights reserved.



PHOTOELECTRIC SENSORS

THRU BEAM

24÷230 V AC - TRIAC NO AND NC OUTPUT

- 18mm tubular in metal housing
- Leakage <1.5 mA @ 220 V AC
- Cable or M12 quick connect models



18 Series



IDENTIFICATION CODE

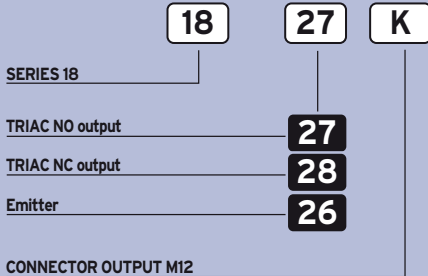

AVAILABLE	RECEIVER	EMITTER
NOMINAL SWITCHING DISTANCE (Sn)	5 m	
TOLERANCE	+10/-10 %Sn	
HYSTERESIS	10%	
EMISSION	-	Infrared (875 nm)
NOMINAL VOLTAGE	24 ÷ 230VAC (-15 /+10%)	
MAINS FREQUENCY	50 ÷ 60 Hz	
MAX. OUTPUT CURRENT	150 mA	-
LEAKAGE CURRENT	1.5mA (at 220VAC)	-
ABSORPTION	1 W	-
VOLTAGE DROP (Sensor ON)	< 2.5 V	
OPERATION LED	Yellow	
SWITCHING FREQUENCY	10 Hz	
RESPONSE TIME	50 ms	
START UP DELAY	300 ms	
ELECTRIC PROTECTIONS	Against inductive loads	
TEMPERATURE LIMITS	-10 ÷ +60 °C	
LIGHT IMMUNITY	2000 Lux ⁽¹⁾	
PROTECTION DEGREE	IP 67 (IP 65 for models with sensitivity adjustment)	
CABLE LENGTH	2 m	
CABLE SECTION	3 x 0.35 mm ²	2 x 0.25 mm ²
HOUSING MATERIAL	Housing: nickel-plated brass - Lenses: methacrylate	
WEIGHT - cable output -	120 g	

⁽¹⁾ Determined with halogen tungsten lamp 3000 °K.
 Note: for a proper use see norms at pages 18, 19, 20, 21 and 22.

WIRING DIAGRAMS

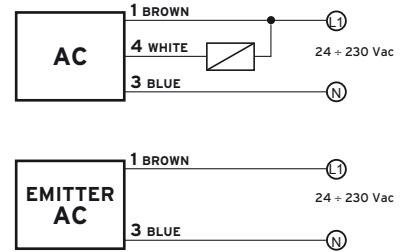

WARNING: Short circuit in the output is not possible. Wrong supply cables connections can irreparably damage the detector. Therefore sensors whose output status is short-circuited will not be substituted under warranty.

CONNECTIONS IN PARALLEL: In parallel connections with multiple outputs, the maximum leakage current (<1,5 mA at 220 VAC) referring to the load and the supply should be taken into account when calculating the max. quantity of connectable sensors. It is important in this connection that the sensors are connected at the same phase.

ACCESSORIES

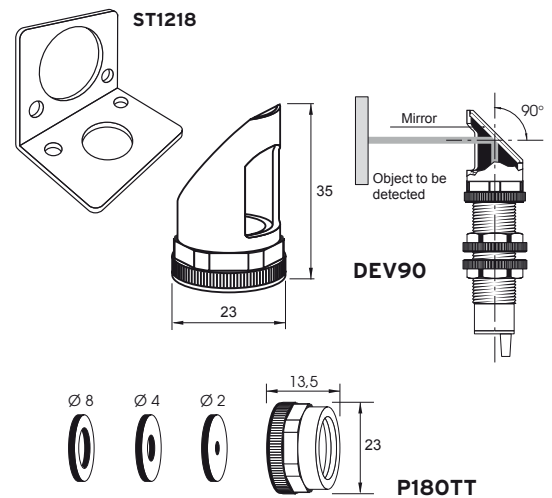

DIMENSIONS (mm)

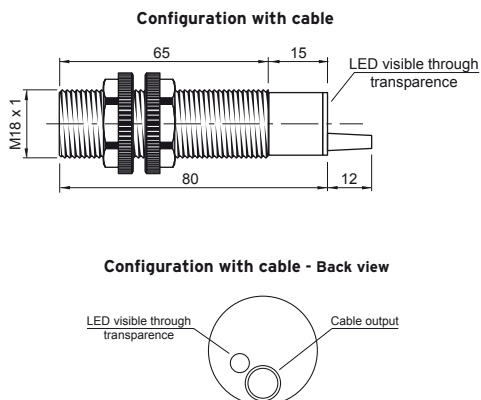

CHARACTERISTIC CURVES

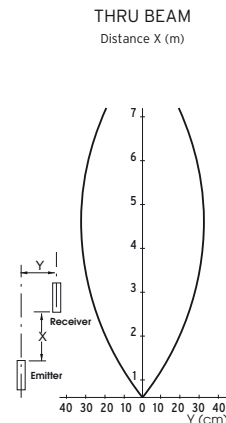



THRU BEAM PHOTOELECTRIC SENSORS



EXTERNAL WALL MOUNTING 180° ROTATING OPTICS

- 15 m range
- New appealing plastic housing
- Output LED indicator
- 2 relays SPDT
- Conforming to EN 12978

P60 Series



IDENTIFICATION CODE

P **60**

SERIES P

12 ÷ 24 V AC/DC

Note: Each package includes emitter and receiver.

AVAILABLE	RECEIVER	EMITTER
NOMINAL SWITCHING DISTANCE (Sn)	15 m	
TOLERANCE	+10/-10 %Sn	
EMISSION	Infrared (875 nm)	
NOMINAL VOLTAGE	12-24 V AC/DC	
FREQUENCY	50 ÷ 60 Hz	
OUTPUT	2 Relay	-
N° OF OPERATIONS	Mec.=5x10 ⁶ ops min. Elect. 3x10 ⁵ ops min. (1A 24 VDC) 1x10 ⁵ ops min. (0.5A 120 VAC)	
MAX OUTPUT CURRENT	1A 24VDC - 0,5A 120 VAC (24W, 60VA)	-
ABSORPTION	40 mA	40 mA
YELLOW LED	Output indicator	-
GREEN LED	-	Supply indicator
SWITCHING FREQUENCY	10 Hz	
START UP DELAY	≤ 300 ms	
TEMPERATURE LIMITS	-20 ÷ +60°C	
LIGHT IMMUNITY	> 30000 Lux ⁽¹⁾	
PROTECTION DEGREE	IP 54	
CONNECTIONS	clamps	
HOUSING MATERIAL	PMMA	
WEIGHT in carton box (approx.)	180 g	

⁽¹⁾ Determined with halogen tungsten lamp 3000 °K

WIRING DIAGRAMS

EMITTER

RECEIVER

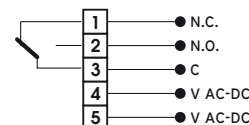

DETAILED SIGHT



DIMENSIONS (mm)

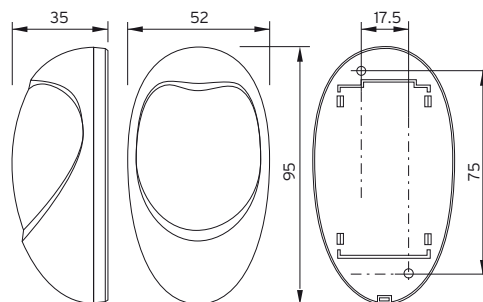

IMPORTANT WARNING

The thru beam photoelectric sensor can be used as a sensor to detect the presence of an obstacle if the sensing beam gets interrupted. In no case this device can substituted the obligatory safety devices that must be applied on all dangerous equipments.

CHARACTERISTICS CURVE

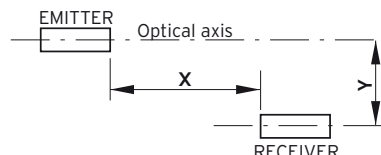
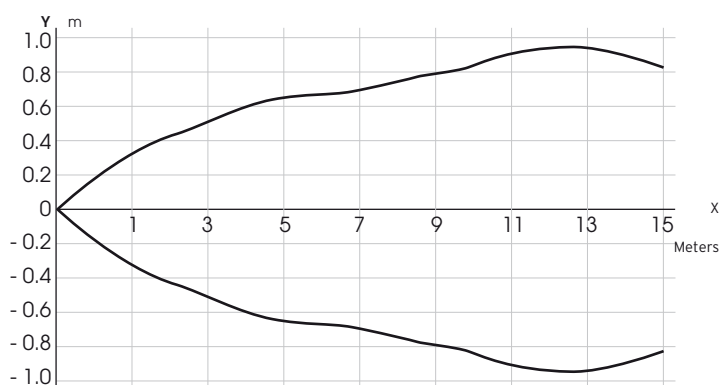



THRU BEAM PHOTOELECTRIC SENSORS



EXTERNAL WALL MOUNTING FIXED OPTICS

- 15 m range
- New appealing plastic housing
- Output LED indicator
- 2 relays SPDT
- Conforming to EN 12978

P61 Series



IDENTIFICATION CODE

P **61**

SERIES P

12 ÷ 24 V AC/DC

Note: Each package includes emitter and receiver.

AVAILABLE	RECEIVER	EMITTER
NOMINAL SWITCHING DISTANCE (Sn)	15 m	
TOLERANCE	+10/-10 %Sn	
EMISSION	Infrared (875 nm)	
NOMINAL VOLTAGE	12-24 V AC/DC	
FREQUENCY	50 ÷ 60 Hz	
OUTPUT	2 Relay	-
N° OF OPERATIONS	Mec.=5x10 ⁶ ops min. Elect. 3x10 ⁵ ops min. (1A 24 VDC) 1x10 ⁵ ops min. (0.5A 120 VAC)	
MAX OUTPUT CURRENT	1A 24VDC - 0,5A 120 VAC (24W, 60VA)	-
ABSORPTION	40 mA	40 mA
YELLOW LED	Output indicator	-
GREEN LED	-	Supply indicator
SWITCHING FREQUENCY	10 Hz	
START UP DELAY	≤ 300 ms	
TEMPERATURE LIMITS	-20 ÷ +60°C	
LIGHT IMMUNITY	> 30000 Lux ⁽¹⁾	
PROTECTION DEGREE	IP 54	
CONNECTIONS	clamps	
HOUSING MATERIAL	PMMA	
WEIGHT in carton box (approx.)	170 g	

⁽¹⁾ Determined with halogen tungsten lamp 3000° K.

WIRING DIAGRAMS

EMITTER

RECEIVER

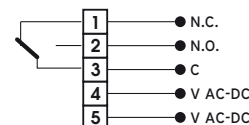

DETAILED SIGHT

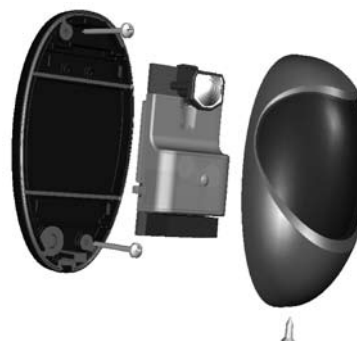

DIMENSIONS (mm)

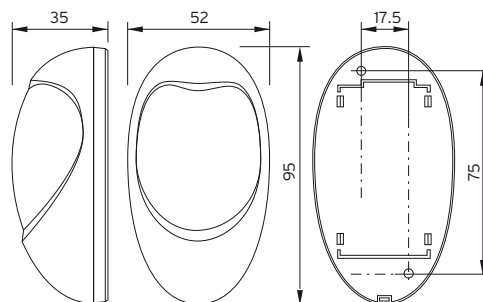

IMPORTANT WARNING

The thru beam photoelectric sensor can be used as a sensor to detect the presence of an obstacle if the sensing beam gets interrupted. In no case this device can substituted the obligatory safety devices that must be applied on all dangerous equipments.

CHARACTERISTICS CURVE

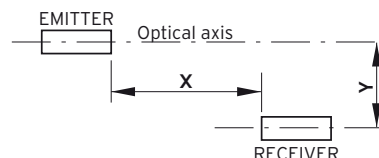
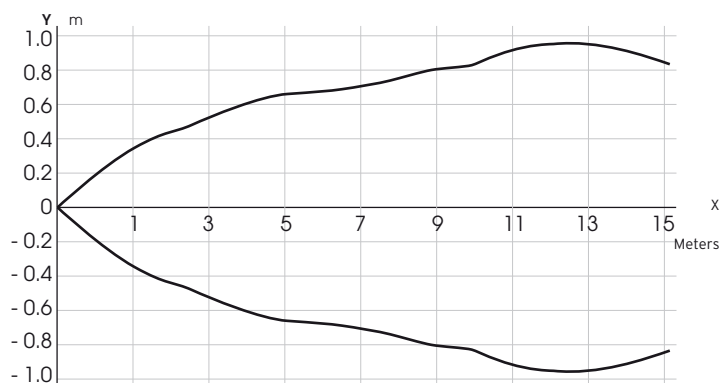



THRU BEAM PHOTOELECTRIC SENSORS



EXTERNAL WALL MOUNTING 180° ROTATING OPTICS

- 15 m range
- New appealing plastic housing
- Output LED indicator
- 2 relays SPDT
- Conforming to EN 12978

P62 Series



IDENTIFICATION CODE

P **62**

SERIES P

12 ÷ 24 V AC/DC

Note: Each package includes emitter and receiver.

AVAILABLE	RECEIVER	EMITTER
NOMINAL SWITCHING DISTANCE (Sn)	15 m	
TOLERANCE	+10/-10 %Sn	
EMISSION	Infrared (875 nm)	
NOMINAL VOLTAGE	12-24 V AC/DC	
FREQUENCY	50 ÷ 60 Hz	
OUTPUT	2 Relay	-
N° OF OPERATIONS	Mec.=5x10 ⁶ ops min. Elect. 3x10 ⁵ ops min. (1A 24 VDC) 1x10 ⁵ ops min. (0.5A 120 VAC)	
MAX OUTPUT CURRENT	1A 24VDC - 0,5A 120 VAC (24W, 60VA)	-
ABSORPTION	40 mA	40 mA
YELLOW LED	Output indicator	-
GREEN LED	-	Supply indicator
SWITCHING FREQUENCY	5 Hz	
START UP DELAY	≤ 300 ms	
TEMPERATURE LIMITS	-20 ÷ +60 °C	
LIGHT IMMUNITY	> 5000 Lux ⁽¹⁾	
PROTECTION DEGREE	IP 54	
CONNECTIONS	clamps	
HOUSING MATERIAL	PMMA	
WEIGHT in carton box (approx.)	160 g	

⁽¹⁾ Determined with halogen tungsten lamp 3000 °K

WIRING DIAGRAMS

EMITTER

RECEIVER

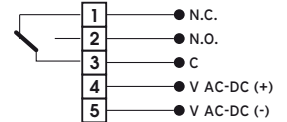

DETAILED SIGHT

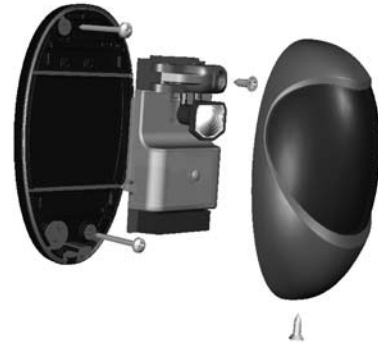

DIMENSIONS (mm)

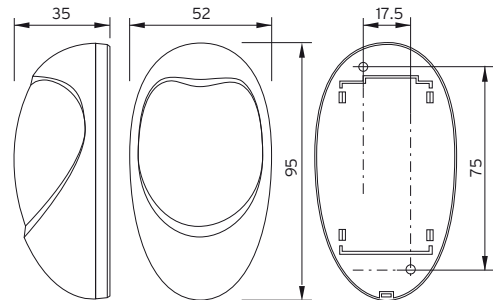

IMPORTANT WARNING

The thru beam photoelectric sensor can be used as a sensor to detect the presence of an obstacle if the sensing beam gets interrupted. In no case this device can substituted the obligatory safety devices that must be applied on all dangerous equipments.

CHARACTERISTICS CURVE

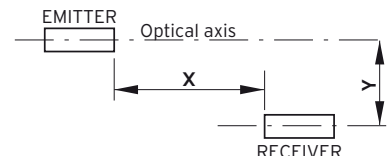
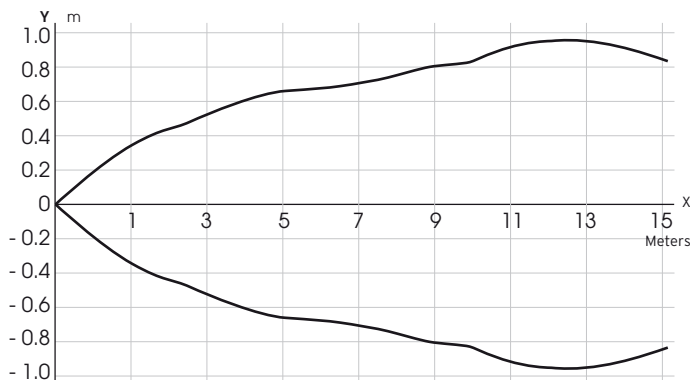



THRU BEAM PHOTOELECTRIC SENSORS



EXTERNAL WALL MOUNTING FIXED OPTICS

- 15 m range
- New appealing plastic housing
- Output LED indicator
- 2 relays SPDT
- Conforming to EN 12978

P63 Series



IDENTIFICATION CODE

P **63**

SERIES P

12 ÷ 24 V AC/DC

Note: Each package includes emitter and receiver.

AVAILABLE	RECEIVER	EMITTER
NOMINAL SWITCHING DISTANCE (Sn)	15 m	
TOLERANCE	+10/-10 %Sn	
EMISSION	Infrared (875 nm)	
NOMINAL VOLTAGE	12-24 V AC/DC	
FREQUENCY	50 ÷ 60 Hz	
OUTPUT	2 Relay	-
N° OF OPERATIONS	Mec.=5x10 ⁶ ops min. Elect. 3x10 ⁵ ops min. (1A 24 VDC) 1x10 ⁵ ops min. (0.5A 120 VAC)	
MAX OUTPUT CURRENT	1A 24VDC - 0.5A 120 VAC (24W, 60VA)	-
ABSORPTION	40 mA	40 mA
YELLOW LED	Output indicator	-
GREEN LED	-	Supply indicator
SWITCHING FREQUENCY	5 Hz	
START UP DELAY	≤ 300 ms	
TEMPERATURE LIMITS	-20 ÷ +60 °C	
LIGHT IMMUNITY	> 5000 Lux ⁽¹⁾	
PROTECTION DEGREE	IP 54	
CONNECTIONS	clamps	
HOUSING MATERIAL	PMMA	
WEIGHT in carton box (approx.)	150 g	

⁽¹⁾ Determined with halogen tungsten lamp 3000 °K

WIRING DIAGRAMS

EMITTER

RECEIVER

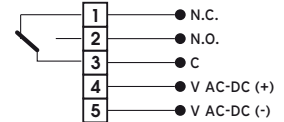

DETAILED SIGHT

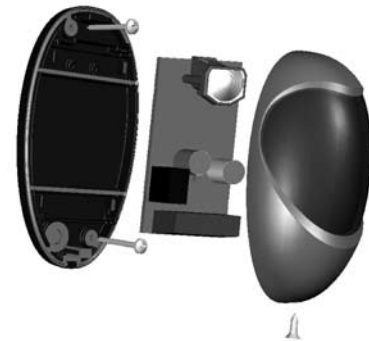

DIMENSIONS (mm)

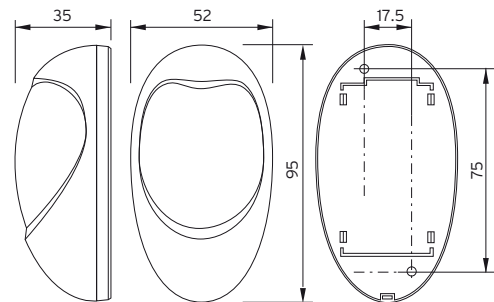

IMPORTANT WARNING

The thru beam photoelectric sensor can be used as a sensor to detect the presence of an obstacle if the sensing beam gets interrupted. In no case this device can substituted the obligatory safety devices that must be applied on all dangerous equipments.

CHARACTERISTICS CURVE

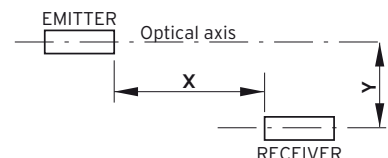
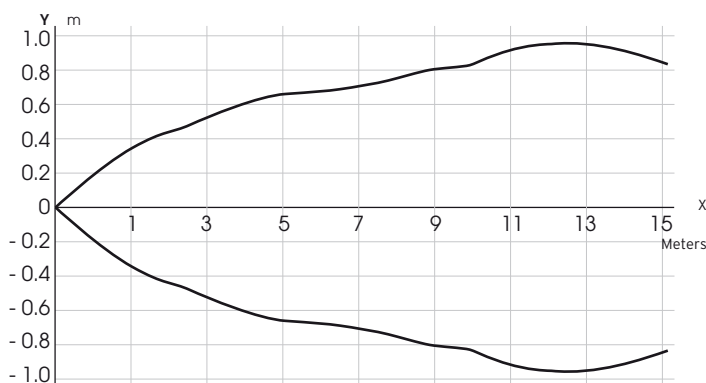



PHOTOELECTRIC SENSORS



THRU BEAM EXTERNAL PANEL MOUNTING

- Conforming to EN 12978
- Long range Sensor: 55 m range
- User friendly, wide beam alignment
- Output LED indicator
- 1A relay SPDT
- Synchronism between 2 emitters and receivers

P40 Series



IDENTIFICATION CODE

P **40**

SERIES P

12÷24V AC/DC

Note: Each package includes emitter and receiver

AVAILABLE	RECEIVER	EMITTER
NOMINAL SWITCHING DISTANCE (Sn)	55 m	
TOLERANCE	+10/-10 %Sn	
EMISSION	Infrared (875 nm)	
NOMINAL VOLTAGE	12-24 V AC/DC	
FREQUENCY	50 ÷ 60 Hz	
OUTPUT	2 Relay	-
N° OF OPERATIONS	Mec.=5x10 ⁶ ops min. Elect. 3x10 ⁵ ops min. (1A 28 VDC) 1x10 ⁵ ops min. (0.5A 120 VAC)	
MAX OUTPUT CURRENT	1A 28 VDC - 0.5A 120 VAC (28 W, 60 VA)	-
ABSORPTION	40 mA	40 mA
YELLOW LED	Output indicator	-
GREEN LED	Supply indicator	-
SWITCHING FREQUENCY	5 Hz	
START UP DELAY	≤ 300 ms	
TEMPERATURE LIMITS	-20 ÷ +60 °C	
LIGHT IMMUNITY	> 5000 Lux ⁽¹⁾	
PROTECTION DEGREE	IP 54	
CONNECTIONS	with connectors	
HOUSING MATERIAL	Housing: nylon loaded with fiberglass - Filter: methacrylate	
WEIGHT (Approximately)	425 g	

⁽¹⁾ Determined with halogen tungsten lamp 3000 °K.

IMPORTANT WARNING

The thru beam photoelectric sensor can be used as a sensor to detect the presence of an obstacle if the sensing beam gets interrupted. In no case this device can substituted the obligatory safety devices that must be applied on all dangerous equipments.

SYNCHRONISM

This photoelectric thru beam permits to work in synchronism (without mutual interference) with another couple of P40 or P41 photoelectric thru beam. To activate the synchronic working, you must supply the photoelectric thru beam in AC and connect PHASE and NEUTRAL to the same clamps of the emitter and of the receiver.

EXAMPLE: Emitter: 1 + Phase • 2 - Neutral
Receiver: 4 + Phase • 5 - Neutral

If the photocells are supplied in DC, the synchronism function is not activated.

WIRING DIAGRAMS

EMITTER

RECEIVER

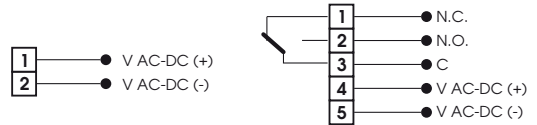

DETAILED SIGHT

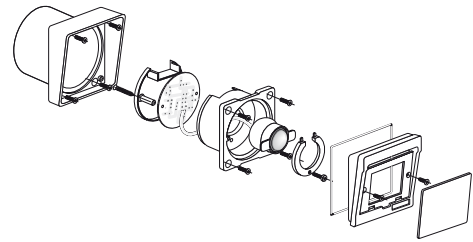

DIMENSIONS (mm)

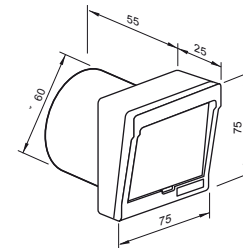

USE WITH ACCESSORIES

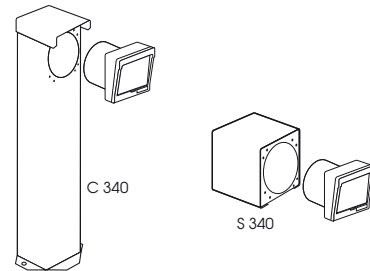

CHARACTERISTICS CURVE

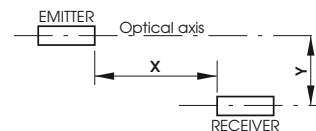
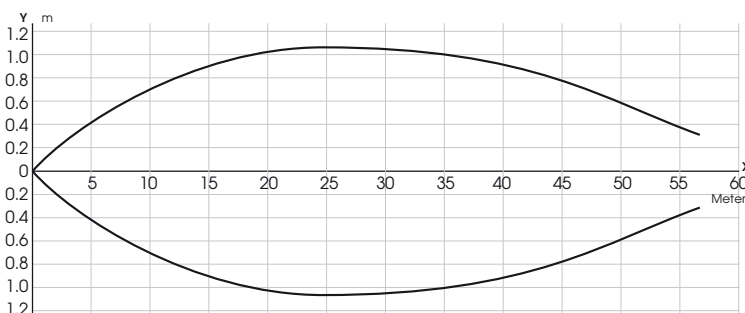

PHOTOELECTRIC SENSORS

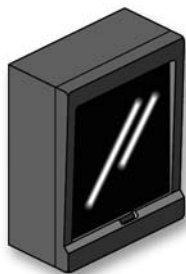

THRU BEAM EXTERNAL WALL MOUNTING

- Conforming to EN 12978
- 35 m range
- Wide beam diameter-easy to align
- Output LED indicator
- 1A relay SPDT
- Synchronism between 2 emitters and receivers

P41 Series



IDENTIFICATION CODE

P **41**

SERIES P

12÷24V AC/DC

Note: Each package includes emitter and receiver

AVAILABLE	RECEIVER	EMITTER
NOMINAL SWITCHING DISTANCE (Sn)	35 m	
TOLERANCE	+10/-10 %Sn	
EMISSION	Infrared (875 nm)	
NOMINAL VOLTAGE	12-24 V AC/DC	
FREQUENCY	50 ÷ 60 Hz	
OUTPUT	2 Relay	-
N° OF OPERATIONS	Mec.=5x10 ⁶ ops min. Elect. 3x10 ⁵ ops min. (1A 28 VDC) 1x10 ⁵ ops min. (0.5A 120 VAC)	
MAX OUTPUT CURRENT	1A 28 VDC - 0.5A 120 VAC (28 W, 60 VA)	-
ABSORPTION	40 mA	40 mA
YELLOW LED	Output indicator	-
GREEN LED	Supply indicator	-
SWITCHING FREQUENCY	5 Hz	
START UP DELAY	≤ 300 ms	
TEMPERATURE LIMITS	-20 ÷ +60 °C	
LIGHT IMMUNITY	> 5000 Lux ⁽¹⁾	
PROTECTION DEGREE	IP 54	
CONNECTIONS	with connectors	
HOUSING MATERIAL	Housing: nylon loaded with fiberglass - Filter: methacrylate	
WEIGHT (Approximately)	315 g	

⁽¹⁾ Determined with halogen tungsten lamp 3000 °K.

IMPORTANT WARNING

The thru beam photoelectric sensor can be used as a sensor to detect the presence of an obstacle if the sensing beam gets interrupted. In no case this device can substituted the obligatory safety devices that must be applied on all dangerous equipments.

SYNCHRONISM

This photoelectric thru beam permits to work in synchronism (without mutual interference) with another couple of P40 or P41 photoelectric thru beam. To activate the synchronic working, you must supply the photoelectric thru beam in AC and connect PHASE and NEUTRAL to the same clamps of the emitter and of the receiver.

EXAMPLE: Emitter: 1 + Phase • 2 - Neutral
Receiver: 4 + Phase • 5 - Neutral

If the photocells are supplied in DC, the synchronism function is not activated.

WIRING DIAGRAMS

EMITTER

RECEIVER



DETAILED SIGHT

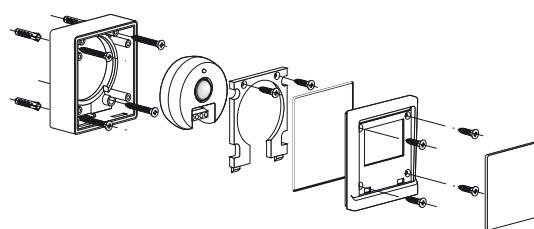

DIMENSIONS (mm)

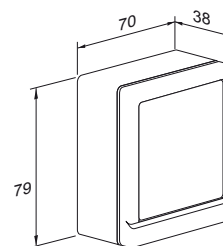

USE WITH ACCESSORIES

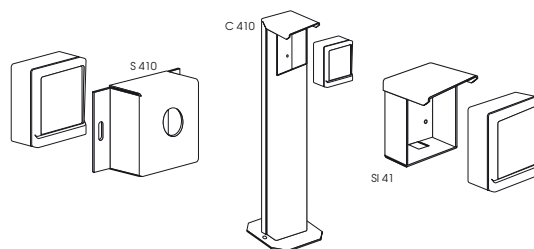

CHARACTERISTICS CURVE

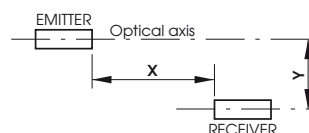
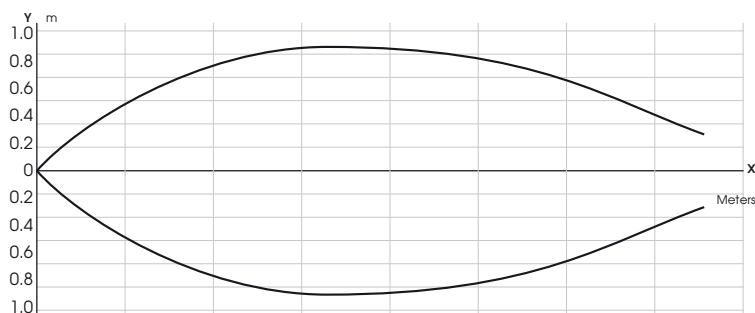

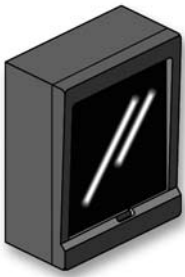

PHOTOELECTRIC SENSORS



THRU BEAM EXTERNAL WALL MOUNTING

- Battery supply
- Low voltage 12-24 AC/DC receiver
- Battery-operated 9V emitter - 150 days minimum
- Conforming to EN 12978
- Solar cell power supply on request

P44 Series



IDENTIFICATION CODE

P

44

SERIES P

FOR EXTERNAL WALL MOUNTING WITH BATTERY SUPPLY

Note: Each package includes emitter, receiver and the alkaline battery for the emitter.

AVAILABLE	RECEIVER	EMITTER
NOMINAL SWITCHING DISTANCE (Sn)	15 m	
TOLERANCE	+10/-10 %Sn	
EMISSION	Infrared (875 nm)	
NOMINAL VOLTAGE	12-24 VAC-DC (selectable)	9V alkaline battery
FREQUENCY	50 ÷ 60 Hz	-
OUTPUT	2 Relay UNI 8612 norms	-
N° OF OPERATIONS	(5x10 ⁶ mec. op. - 100x10 ³ elect. op.)	-
MAX OUTPUT CURRENT	1A 24 VDC - 0.5A 120 VAC	-
BATTERY LIFE		150 days (min.)
ABSORPTION	70 mA	-
YELLOW LED	Output indicator	
GREEN LED	Supply indicator	
SWITCHING FREQUENCY	1 Hz	
RESPONSE TIME	500 ms	
START UP DELAY	≤ 300 ms	
TEMPERATURE LIMITS	-20 ÷ +60 °C	
LIGHT IMMUNITY	> 5000 Lux ⁽¹⁾	
PROTECTION DEGREE	IP 54	
CONNECTIONS	with connectors	
HOUSING MATERIAL	Housing: nylon loaded with fiberglass - Filter: methacrylate	
WEIGHT (Approximately)	340 g	

⁽¹⁾ Determined with halogen tungsten lamp 3000 °K.

IMPORTANT WARNING

The thru beam photoelectric sensor can be used as a sensor to detect the presence of an obstacle if the sensing beam gets interrupted. In no case this device can substituted the obligatory safety devices that must be applied on all dangerous equipments.

WIRING DIAGRAMS

EMITTER

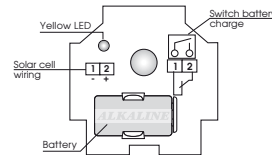

RECEIVER

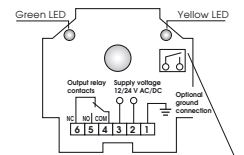

Connect the connectors 1 and 2 to the sensitive edge output contact to activate the beam emission.

WARNING: Do not connect other supply sources to the connectors 1 and 2 or to the battery plug. The device could be irreparably damaged.

Note: Connect to ground the connector 1.

DETAILED SIGHT

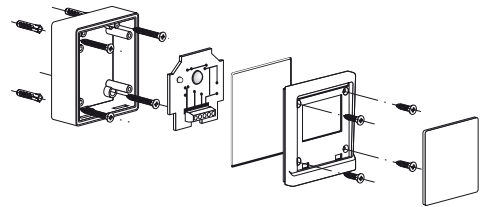

DIMENSIONS (mm)

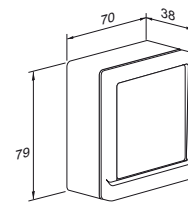

USE WITH ACCESSORIES

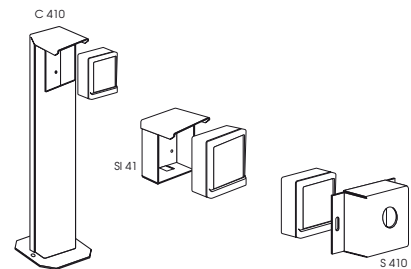

CHARACTERISTICS CURVE

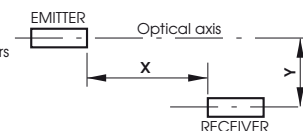
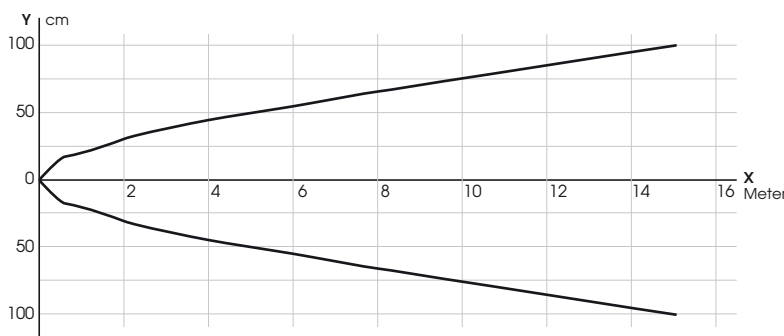

ACCESSORIES



SOLAR CELL FOR PHOTOELECTRIC THRU BEAM P44

- 9 V DC solar cell
- Material: transparent methacrylate
- Cable length: 6 m
- Protection degree: IP67

SCP44 Series



PRODUCT DESCRIPTION

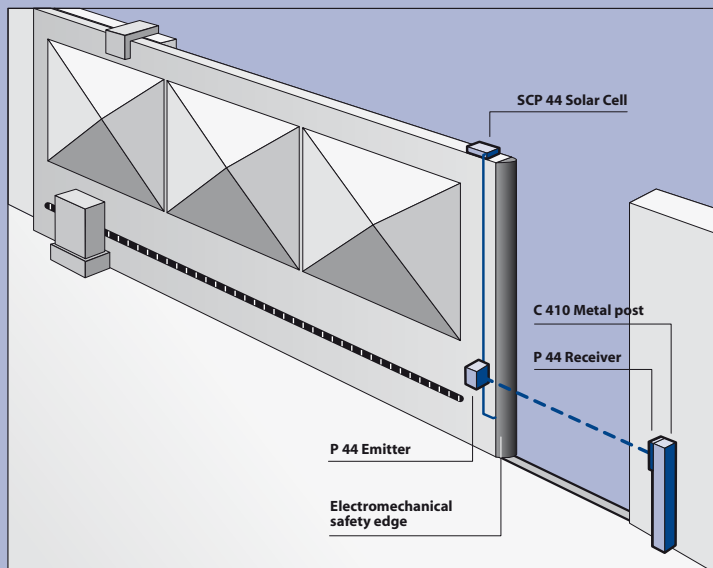

P44 TX AVERAGE CONSUMPTION 0,17 mA

TYPICAL VALUES REFERRED TO THE ENVIRONMENTAL TEMPERATURE (25C) VALIDS WITH A MARGIN OF 10%	ELECTRICAL DATA RELATED TO RADIATION	
	@ 10 mW/cm ²	@ 100 mW/cm ²
NOMINAL POWER	2.7 mW	33.5 mW
OPEN CIRCUIT VOLTAGE	11.4 V	13,7 V
VOLTAGE AT NOMINAL POWER	8.4 V	10.0 V
SHORT CIRCUIT CURRENT	0.38 mA	3.9 mA
CURRENT AT NOMINAL POWER	0.30 mA	3.2 mA

TEMPERATURE COEFFICIENTS:	
RELATED TO THE OPEN CIRCUIT VOLTAGE	$\alpha = -0.33\% / K$
RELATED TO THE SHORT CIRCUIT CURRENT	$\beta = -0.08\% / K$
RELATED TO THE NOMINAL POWER	$\gamma = -0.20\% / K$

SPECTRUM ANSWER:	
RANGE WAVE-LENGTH	350 820 nm
MAX. EFFICIENCY WAVE-LENGTH	580 nm

APPROX. INFORMATION RELATED TO RADIATION 1 mW/cm ² / 1250 Lux		
	mW/cm ²	Lux
FULLY SUNNY DAY	120 100	150000 125000
SLIGHTLY OVERCAST SKY	100 80	125000 100000
CLOUDY SKY	80 20	100000 25000
RAIN	20 3	25000 3750

APPLICATIONS FOR SCP44 AND P44

INFRA developed the solar cell SCP 44 to be used together with the thru beam photoelectric sensor P 44 which has already been provided with a 9 V DC supplementary supply input for a direct connection with the solar cell. When you use a rechargeable battery with the solar cell, is necessary to close the switch battery charge in the P44 emitter. Otherwise this switch must be open.

The P 44 emitter has got also a further input to connect the protection sensitive edge; this allows the interruption information transmission (pressing) of the same "edge" through the P 44 emitter (when the edge is pressed, an electric contact on the emitter is closed and prevents the light transmission, as if there were an obstacle between the emitter and the receiver).

Therefore, if you simply install the emitter and connect it to the control station, it is possible to get the following advantages:

- 1) it will not be necessary to install a supply cable for the emitter
- 2) it will not be necessary to install a cable (moving) for the sensitive edge
- 3) when installing the solar cell in a place well exposed to sunlight, the battery life can increase up to 2 years
- 4) the couple of P 44 thru beam photoelectric sensors replaces the photocells that are normally mounted first the automatic gate (in the internal part).

WIRING DIAGRAMS P44

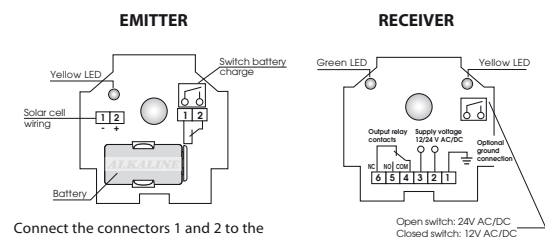

Connect the connectors 1 and 2 to the sensitive edge output contact to activate the beam emission.

WARNING: Do not connect other supply sources to the connectors 1 and 2 or to the battery plug. The device could be irreparably damaged.

Note: Connect to ground the connector 1.

WIRING DIAGRAMS SCP44

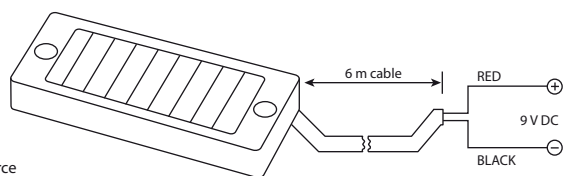

Warning: do not connect any supply source to the solar cell wires.

DIMENSIONS (mm)

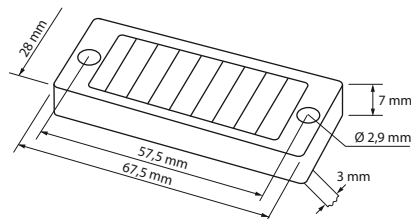

ACCESSORIES

FOR THRU BEAM PHOTOELECTRIC SENSORS

EXTERNAL BOX AND METAL POST

- Anti-vandalism box
- Material: zinc-coated iron
- Epossidic painted

C and S Series



BOX FOR P 40 (ART. S 340)

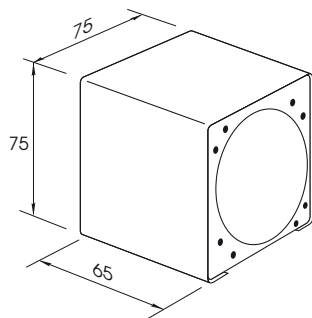

Metal box for wall mounting of model P40.
Epossidic painted. Colour grey.
Material: zinc-coated iron.

Weight 270 g

Post for P 40 (Art. C 340)

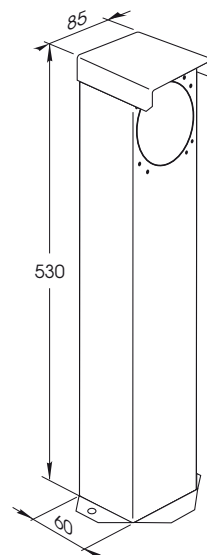

Metal post to support the model P40.
Epossidic painted.
Colour grey.
Material: zinc-coated iron.

Weight 1600 g

ANTI-VANDALISM BOX FOR P 41 - P 44 (ART. S 410)

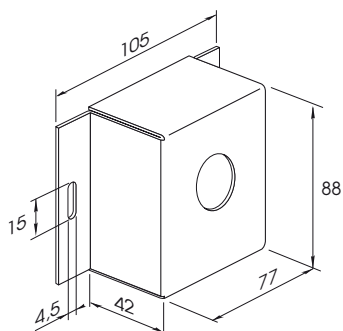

Anti-vandalic metal box for model P41-P44.
Colour grey.
Material: zinc-coated iron.

Weight 240 g

Post for P 41 - P 44 (Art. C 410)

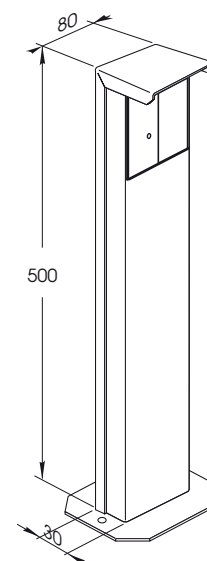

Metal post to support the model P41-P44.
Epossidic painted.
Colour grey.
Material: zinc-coated iron.

Weight 1200 g

BOX FOR P 41 - P 44 (ART. SI 41)

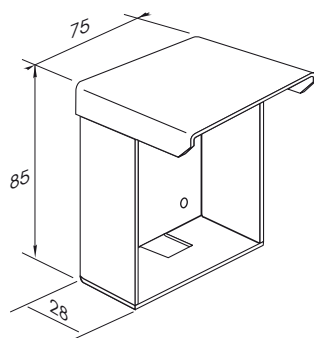

Metal box for wall mounting of model P41.
Epossidic painted. Colour grey.
Material: zinc-coated iron.

Weight 160 g

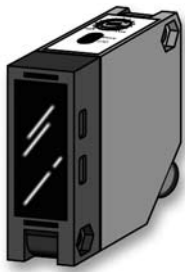

PHOTOELECTRIC SENSORS



RETRO REFLECTIVE 12÷30 V DC PROGRAMMABLE OUTPUT

- Square housing
- Compact size, output and stability indicators
- Cost effective
- Cable or M12 quick connect models
- Fast response time: 2.5 ms / 200 Hz
- Version for transparent

FQ Series



IDENTIFICATION CODE

FQ **02** **P** **T*** **K**

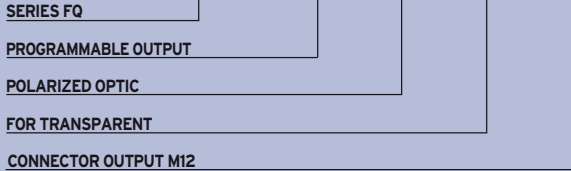

* Long tail option not available with option "K".

AVAILABLE	POLARIZED	POLAR. FOR TRANSPARENT	STANDARD
NOMINAL SWITCHING DISTANCE (Sn)	6 m ⁽¹⁾	0,05 ÷ 2m ⁽¹⁾	13 m ⁽¹⁾
TOLERANCE	+10/-10 %Sn		
HYSTERESIS	10%		
EMISSION	Red (660 nm)	Infrared (875 nm)	
NOMINAL VOLTAGE	12 ÷ 30VDC (-15 /+10%)		
RESIDUAL RIPPLE	10%		
OUTPUT	NPN or PNP (programmable)		
CONTACT	NO or NC (programmable)		
MAX. OUTPUT CURRENT	200 mA		
ABSORPTION AT 30 VDC	40 mA		
VOLTAGE DROP (Sensor ON)	1.8 V (I = 100 mA)		
YELLOW LED	Output indicator		
GREEN LED	Supply indicator		
SENSITIVITY ADJUSTMENT	Trimmer 1 turn		
SWITCHING FREQUENCY	200 Hz		
RESPONSE TIME	2.5 ms		
START UP DELAY	100 ms		
SHORT CIRCUIT PROTECTION	Present (self-resetting)		
ELECTRIC PROTECTIONS	Against polarity reversal - inductive loads		
TEMPERATURE LIMITS	-10 ÷ +60 °C		
LIGHT IMMUNITY	> 10.000 Lux ⁽²⁾		
PROTECTION DEGREE	IP 65		
CABLE LENGTH	2 m		
CABLE SECTION	4 x 0.25 mm ²		
HOUSING MATERIAL	Housing: ABS - Lenses: methacrylate		
WEIGHT - cable output - (connector output)	- 160 g - (120 g)		

⁽¹⁾ Determined with CTO4S reflector.

⁽²⁾ Determined with halogen tungsten lamp 3000 °K.

Note: for a proper use see norms at pages 18, 19, 20, 21 and 22.

WIRING DIAGRAMS

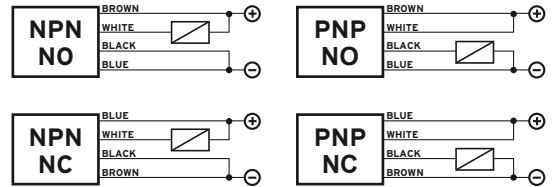

CONNECTION WITH CONNECTOR M12 (K)

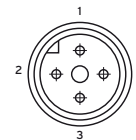

CONTACTS CONFIGURATION

Output	Contacts numbers			
	1	2	3	4
NPN NO	+	NO	-	-
NPN NC	-	NC	+	-
PNP NO	+	+	-	NO
PNP NC	-	+	+	NC
Emitter	+	-	-	-

View of quadripole male connector.

Note: Photoelectric sensor not suitable for use with 90° connectors.

SENSITIVITY ADJUSTMENT

- 1) SENSITIVITY INCREASE**
Screw the trimmer towards right towards position "+"
- 2) SENSITIVITY DECREASE**
Screw the trimmer towards left towards position "-"

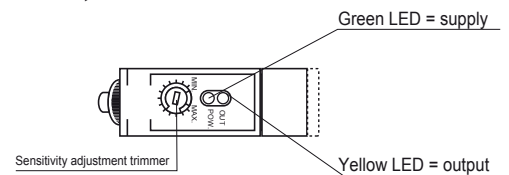

Note: the trimmer just needs one turn.

DIMENSIONS (mm)

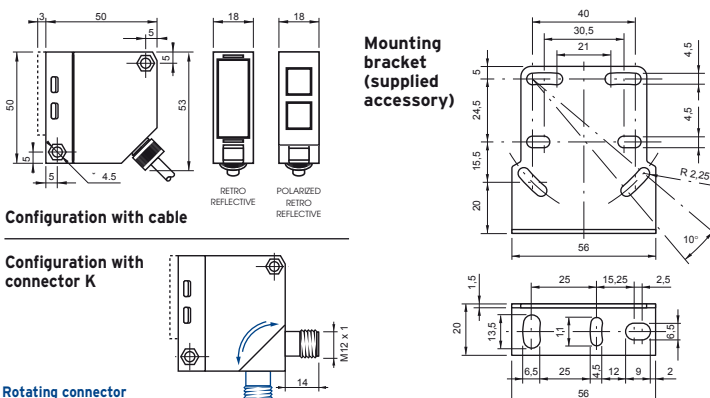

CHARACTERISTIC CURVES

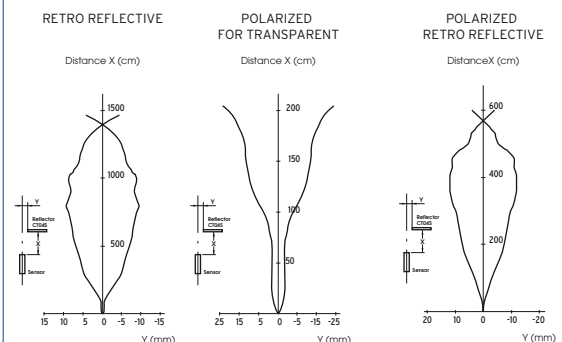

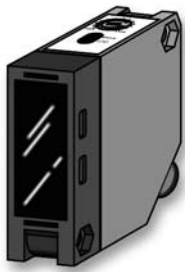

PHOTOELECTRIC SENSORS



RETRO REFLECTIVE

14÷230 V AC/DC PROGRAMMABLE OUTPUT

- Square housing
- Wide input voltage
- 3A relay SPDT
- Cable or M12 quick connect models
- Output and Supply indicators

FQ Series



IDENTIFICATION CODE

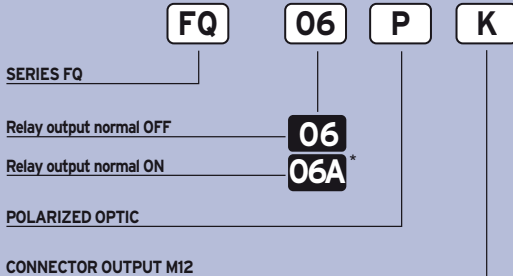

* This version is made with NORMALLY ACTIVATED RELAY when the photocell is aligned with the reflector.

AVAILABLE	POLARIZED	STANDARD
NOMINAL SWITCHING DISTANCE (Sn)	6 m ⁽¹⁾	13 m ⁽¹⁾
TOLERANCE	+10/-10 %Sn	
HYSTERESIS	10%	
EMISSION	Red (660 nm)	Infrared (875 nm)
NOMINAL VOLTAGE	14 ÷ 230V AC - DC (-15 /+10%)	
MAINS FREQUENCY	50 ÷ 60 Hz	
OUTPUT	Relay (10 x 10 ⁶ ops. min.)	
MAX. OUTPUT CURRENT	3A 30 VAC - 1A 220 VAC (90W, 360 VA)	
ABSORPTION	2.5 VA	
YELLOW LED	Output indicator	
GREEN LED	Supply indicator	
SENSITIVITY ADJUSTMENT	Trimmer 1 turn	
SWITCHING FREQUENCY	10 Hz	
RESPONSE TIME	50 ms	
START UP DELAY	300 ms	
TEMPERATURE LIMITS	-10 ÷ +60 °C	
LIGHT IMMUNITY	> 10.000 Lux ⁽²⁾	
PROTECTION DEGREE	IP 65	
CABLE LENGTH	2 m	
CABLE SECTION	5 x 0.30 mm ²	
HOUSING MATERIAL	Housing: ABS - Lenses: methacrylate	
WEIGHT - cable output - (connector output)	- 180 g - (125 g)	

⁽¹⁾ Determined with CTO4S reflector.

⁽²⁾ Determined with halogen tungsten lamp 3000 °K.

Note: for a proper use see norms at pages 18, 19, 20, 21 and 22.

WIRING DIAGRAMS

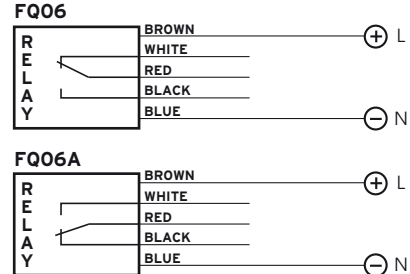

Note: in case of inductive loads it is necessary to connect one diode in antiparallel at the edges of the load.

CONNECTION WITH CONNECTOR M12 (K)

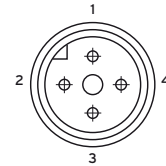

View of quadripole male connector.

CONTACTS CONFIGURATION

Output	Contacts numbers			
	1	2	3	4
Relay	L	COM	N	NO
Wire colors	brown	white	blue	black

Note: Photoelectric sensor not suitable for use with 90° connectors.

SENSITIVITY ADJUSTMENT

- 1) SENSITIVITY INCREASE**
Screw the trimmer towards right towards position "+"
- 2) SENSITIVITY DECREASE**
Screw the trimmer towards left towards position "-"

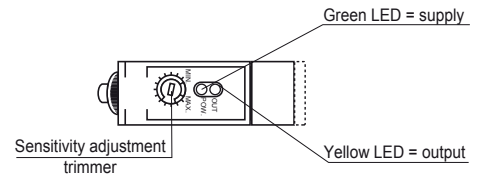

Note: the trimmer just needs one turn.

DIMENSIONS (mm)

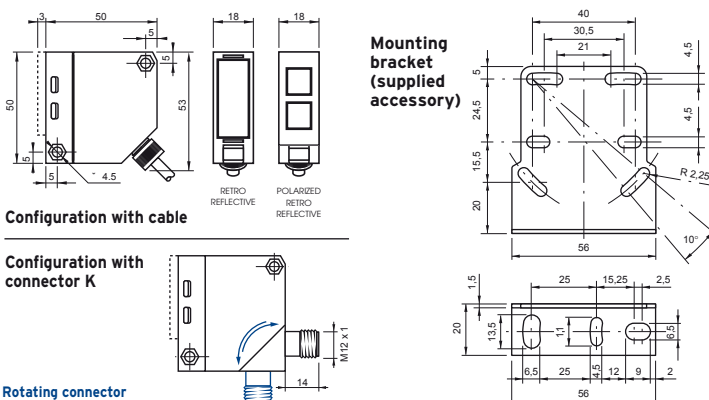

Mounting bracket (supplied accessory)

Configuration with cable

Configuration with connector K

Rotating connector

CHARACTERISTIC CURVES

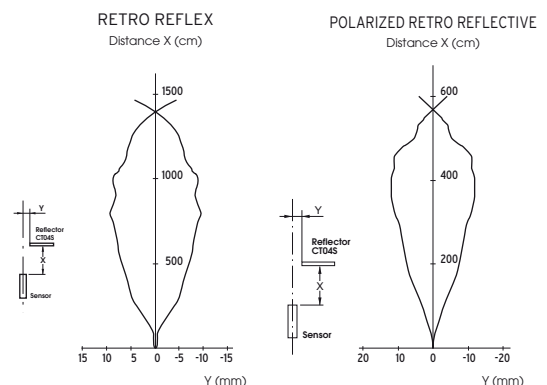



PHOTOELECTRIC SENSORS



RETRO REFLECTIVE

12÷30 V DC WITH PROGRAMMABLE OUTPUT

- Rectangular housing
- Multi-function timer
- ON/OFF delay
- One shot-four functions
- NPN or PNP programmable outputs
- Conduit wiring terminal block

FW Series



IDENTIFICATION CODE

FW **03** **P** **T** **K**

SERIES FW

NPN PNP OUTPUT

POLARIZED OPTIC

TIME DELAY 1 ÷ 7 SEC.

CONNECTOR OUTPUT M12

AVAILABLE	POLARIZED	STANDARD
NOMINAL SWITCHING DISTANCE (Sn)	9 m ⁽¹⁾	15 m ⁽¹⁾
TOLERANCE	+10/-10 %Sn	
HYSTERESIS	10%	
EMISSION	Red (660 nm)	Infrared (875 nm)
NOMINAL VOLTAGE	12 ÷ 30VDC (-15 /+10%)	
RESIDUAL RIPPLE	10%	
OUTPUT	NPN or PNP (programmable)	
MAX OUTPUT CURRENT	200 mA	
ABSORPTION	40 mA	
VOLTAGE DECREASE	2.5 VDC	
YELLOW LED	Light on indicator	
GREEN LED	Supply indicator	
SENSITIVITY ADJUSTMENT	Trimmer 1 turn	
TIME REGULATION	0.1 ÷ 7 s ± 2 s (only models with timer)	
SWITCHING FREQUENCY	200 Hz	
RESPONSE TIME	2.5 ms	
START UP DELAY	300 ms	
PROTECTION AGAINST SHORT-CIRCUIT	Present (self-resetting)	
TEMPERATURE LIMITS	-10° ÷ +60 °C	
LIGHT IMMUNITY	10.000 Lux ⁽²⁾	
PROTECTION DEGREE	IP 67	
CONNECTIONS	Screw or M12 conn.	
CABLE GUIDE	PG 13.5	
HOUSING MATERIAL	Housing: ABS - Lenses: methacrylate	
WEIGHT (Approximately)	110 g	

⁽¹⁾ Determined with CT04S reflector.

⁽²⁾ Determined with halogen tungsten lamp 3000 °K.

Note: for a proper use see norms at pages 18, 19, 20, 21 and 22.

DIMENSIONS (mm)

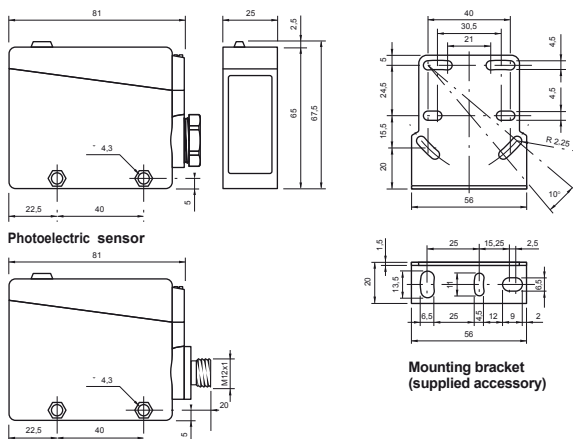

WIRING DIAGRAMS

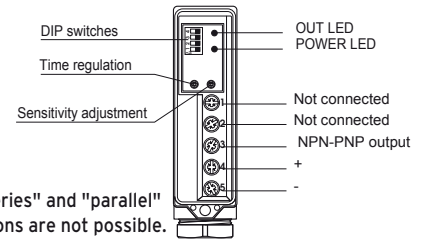

Note: "series" and "parallel" connections are not possible.

CONNECTION WITH CONNECTOR M12 (K)

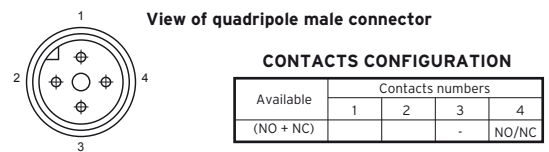

Note: Photoelectric sensor not suitable for use with 90° connectors.

TIMING DIAGRAMS

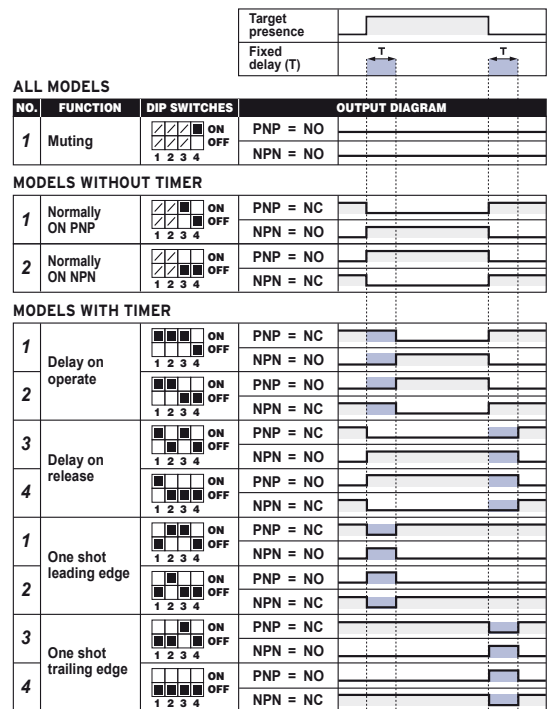

CHARACTERISTIC CURVES

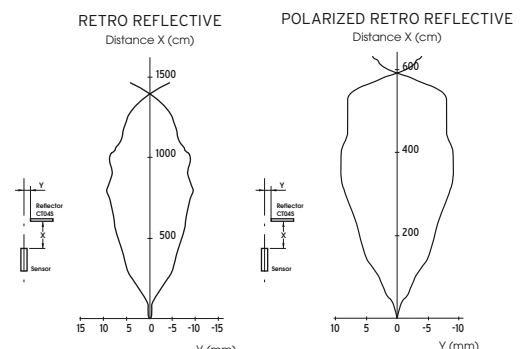



PHOTOELECTRIC SENSORS



RETRO REFLECTIVE

14÷230 V AC/DC WITH TIMER RELAY OUTPUT

- Rectangular housing
- Wide range Power Supply
- Multi-function timer
- ON/OFF delay
- One shot-four functions
- Conduit wiring terminal block

FW Series



IDENTIFICATION CODE

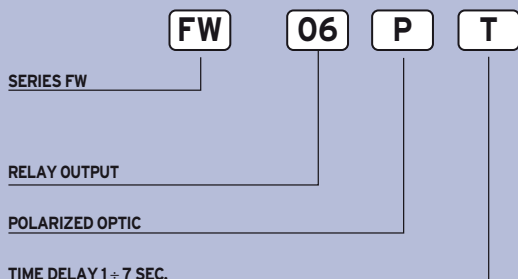

AVAILABLE	POLARIZED	STANDARD
NOMINAL SWITCHING DISTANCE (Sn)	9 m ⁽¹⁾	15 m ⁽¹⁾
TOLERANCE	+10/-10 %Sn	
HYSTERESIS	10%	
EMISSION	Red (660 nm)	Infrared (875 nm)
NOMINAL VOLTAGE	14 ÷ 230 VAC - DC (-15 /+10%)	
NET FREQUENCY	45 ÷ 60 Hz	
OUTPUT	Relay (40 x 10 ⁶ mec. op. -5 x 10 ⁶ elect. op.)	
MAX OUTPUT CURRENT	3A 250VAC - 3A 30VDC	
ABSORPTION	2W (2.5 VA)	
YELLOW LED	Light on indicator	
GREEN LED	Supply indicator	
SENSITIVITY ADJUSTMENT	Trimmer 1 turn	
TIME REGULATION	0.1 ÷ 7 s ± 2 s (only models with timer)	
SWITCHING FREQUENCY	10 Hz	
RESPONSE TIME	50 ms	
START UP DELAY	300 ms	
TEMPERATURE LIMITS	-10 ÷ +60 °C	
LIGHT IMMUNITY	> 10.000 Lux ⁽²⁾	
PROTECTION DEGREE	IP 67	
CONNECTIONS	Screw	
CABLE GUIDE	PG 13.5	
HOUSING MATERIAL	Housing: ABS - Lenses: methacrylate	
WEIGHT (Approximately)	110 g	

⁽¹⁾ Determined with CTO4S reflector.

⁽²⁾ Determined with halogen tungsten lamp 3000 °K.

Note: for a proper use see norms at pages 18, 19, 20, 21 and 22.

WIRING DIAGRAMS

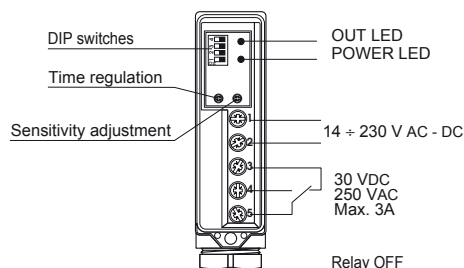

TIMING DIAGRAMS

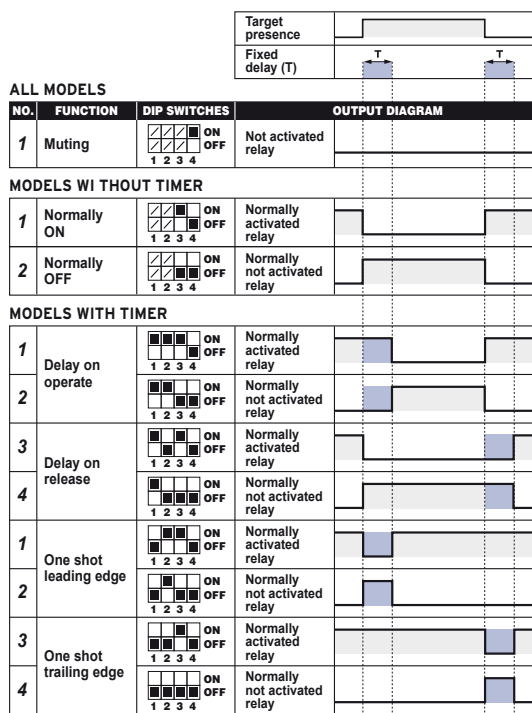

DIMENSIONS (mm)

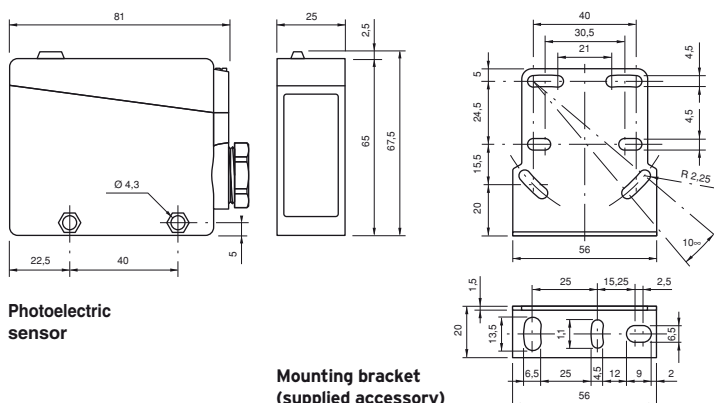

CHARACTERISTIC CURVES

