

PHOTOELECTRIC SENSORS



PHOTOELECTRIC



PHOTOELECTRIC SENSORS



DIFFUSE REFLECTIVE 12÷30 V DC - NPN OR PNP OUTPUT

- 18 mm tubular in metal housing
- Operation LED visible laterally and at the back
- Cable or M12 quick connect models
- Long working distances
- Fast response time: 1 ms / 500 Hz

18 Series



IDENTIFICATION CODE

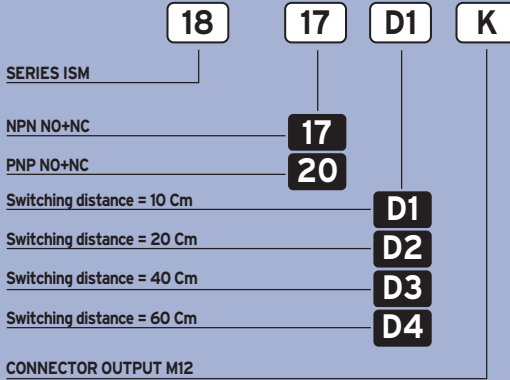

AVAILABLE	D1	D2	D3	D4
NOMINAL SWITCHING DISTANCE (Sn)	10 cm ⁽¹⁾	20 cm ⁽¹⁾	40 cm ⁽¹⁾	60 cm ⁽²⁾
TOLERANCE	+10/-10 %Sn			
HYSTERESIS	10%			
EMISSION	Infrared (875 nm)			
NOMINAL VOLTAGE	12 ÷ 30VDC (-15 / +10%)			
RESIDUAL RIPPLE	10%			
MAX. OUTPUT CURRENT	200 mA			
ABSORPTION AT 30 VDC	40 mA			
VOLTAGE DROP (Sensor ON)	1.5V (I = 200 mA)			
OPERATION LED	Yellow			
SWITCHING FREQUENCY	500 Hz			
RESPONSE TIME	1 ms			
START UP DELAY	100 ms			
SHORT CIRCUIT PROTECTION	Present (self-resetting)			
ELECTRIC PROTECTIONS	Against polarity reversal - inductive loads			
TEMPERATURE LIMITS	-10 ÷ +60 °C			
LIGHT IMMUNITY	> 10.000 Lux ⁽³⁾			
PROTECTION DEGREE	IP 67			
CABLE LENGTH	2 m			
CABLE SECTION	3 x 0.25 mm ²			
HOUSING MATERIAL	Housing: nickel-plated brass - Lenses: methacrylate			
WEIGHT - cable output - (connector output)	- 110 g - (55 g)			

⁽¹⁾ Determined with a white mat paper (cm 10 x 10).
⁽²⁾ Determined with a white mat paper (cm 20 x 20).
⁽³⁾ Determined with halogen tungsten lamp 3000 °K.
 Note: for a proper use see norms at pages 18, 19, 20, 21 and 22.

WIRING DIAGRAMS

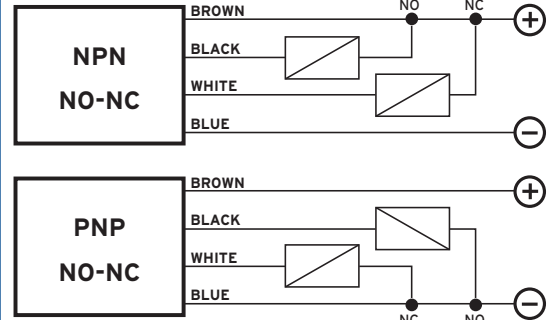

CONNECTION WITH CONNECTOR M12 (K)

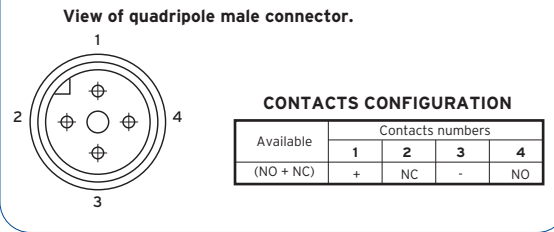

TIMING DIAGRAMS

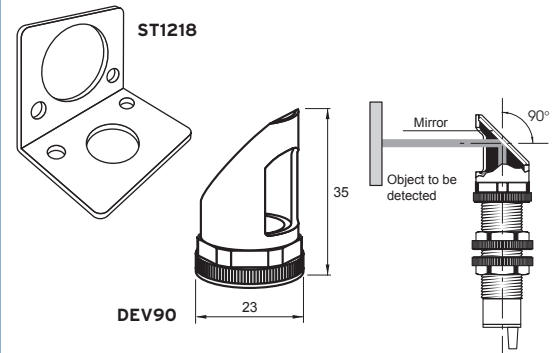

DIMENSIONS (mm)

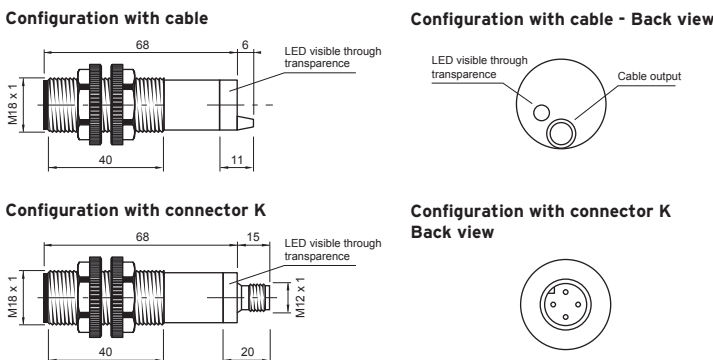

CHARACTERISTIC CURVES

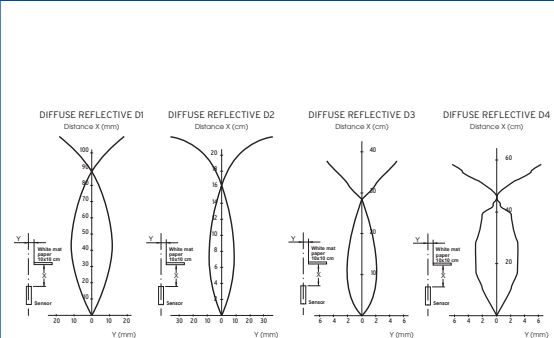

PHOTOELECTRIC

PHOTOELECTRIC SENSORS



DIFFUSE REFLECTIVE 24÷230 V AC - TRIAC NC OUTPUT

- 18mm tubular in plastic housing
- Leakage <1.5 mA@ 220 V AC
- Models w/o pots for simple installation
- Cable or M12 quick connect models
- Models with 9-turn pot
- Models with connector in metal housing

18 Series



IDENTIFICATION CODE

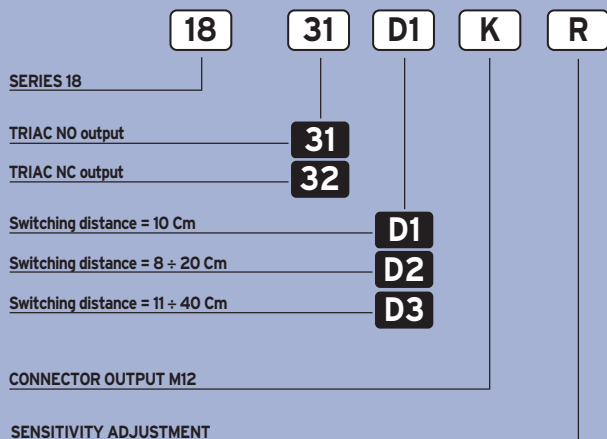

"K" model available only in metal housing.

	D1	D2	D3
NOMINAL SWITCHING DISTANCE (Sn)	10 cm ⁽¹⁾	8 + 20 cm ⁽¹⁾	11 + 40 cm ⁽¹⁾
TOLERANCE	+10/-10 %Sn		
HYSTERESIS	10%		
EMISSION	Infrared (875 nm)		
NOMINAL VOLTAGE	24 ÷ 230VAC (-15 /+10%)		
MAINS FREQUENCY	50 ÷ 60 Hz		
MAX. OUTPUT CURRENT	150 mA		
LEAKAGE CURRENT	1.5mA (at 220VAC)		
ABSORPTION	1 W		
VOLTAGE DROP (Sensor ON)	< 2.5 V		
OPERATION LED	Yellow		
SWITCHING FREQUENCY	10 Hz		
RESPONSE TIME	50 ms		
START UP DELAY	300 ms		
ELECTRIC PROTECTIONS	Against inductive loads		
TEMPERATURE LIMITS	-10 ÷ +60 °C		
LIGHT IMMUNITY	5000 Lux ⁽²⁾		
PROTECTION DEGREE	IP 67 (IP 65 for models with sensitivity adjustment)		
CABLE LENGTH	2 m		
CABLE SECTION	3 x 0.35 mm ²		
HOUSING MATERIAL	Housing: plastic / nickel-plated brass Lenses: methacrylate		
WEIGHT - cable output -	120 g		

⁽¹⁾ Determined with a white mat paper (cm 10 x 10).

⁽²⁾ Determined with halogen tungsten lamp 3000 °K.

Note: for a proper use see norms at pages 18, 19, 20, 21 and 22.

WIRING DIAGRAMS

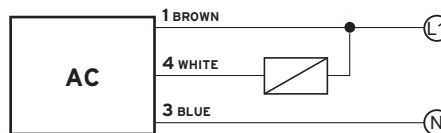

WARNING: Short circuit in the output is not possible. Wrong supply cables connections can irreparably damage the detector. Therefore sensors whose output status is short-circuited will not be substituted under warranty.

CONNECTIONS IN PARALLEL

In parallel connections with multiple outputs, the maximum leakage current (<1,5 mA at 220 VAC) referring to the load and the supply should be taken into account when calculating the max. quantity of connectable sensors. It is important in this connection that the sensors are connected at the same phase.

ACCESSORIES

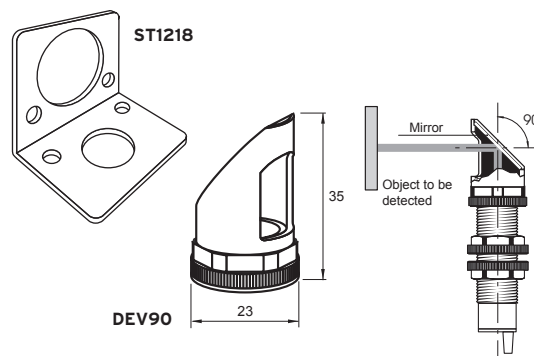

DIMENSIONS (mm)

Configuration with cable

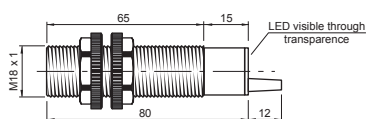

Configuration with cable - Back view

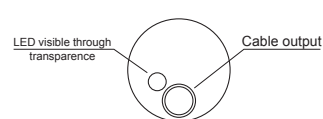

Configuration with connector K (metal housing)

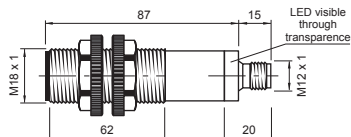

Configuration with sensitivity adjustment

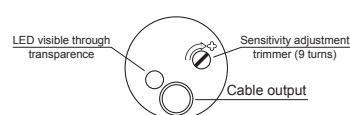

CHARACTERISTIC CURVES

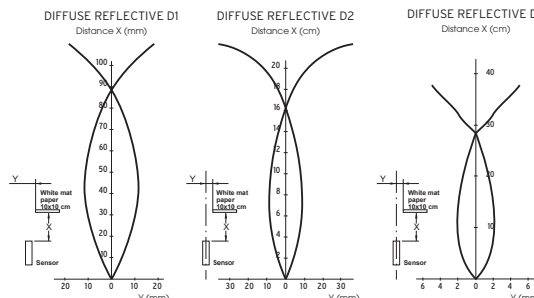



PHOTOELECTRIC SENSORS

DIFFUSE REFLECTIVE 24÷230 V AC - 2 WIRES

- 18mm tubular in metal housing
- Leakage Typ. 2,5 mA@ 230 V AC
- Models w/o post for simple installation
- Cable or M12 quick connect models

18 Series



IDENTIFICATION CODE

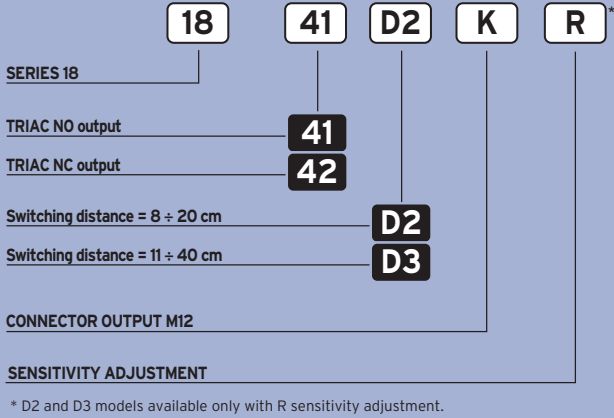

AVAILABLE	D2	D3
NOMINAL SWITCHING DISTANCE (Sn)	8 ÷ 20 cm ⁽¹⁾	11 ÷ 40 cm ⁽²⁾
TOLERANCE	+10/-10%Sn	
HYSTERESIS	3-20%	
EMISSION	Infrared (875 nm)	
NOMINAL VOLTAGE	24 ÷ 230VAC (-15 / +10%)	
MAINS FREQUENCY	50 ÷ 60 Hz	
MAX. OUTPUT CURRENT	500 mA	
LEAKAGE CURRENT (at 230 VAC)	5mA (Typ. 2,5mA)	
VOLTAGE DROP (Sensor ON)	< 10 (Typ. 7) VAC	
OPERATION LED	Yellow	
SWITCHING FREQUENCY	20 Hz	
RESPONSE TIME	Ton<=20ms-Toff<=30ms	
START UP DELAY	Typ. 100 ms	
TEMPERATURE LIMITS	-10 ÷ +60 °C	
LIGHT IMMUNITY	5000 Lux ⁽³⁾	
PROTECTION DEGREE	IP 67	
CABLE LENGTH	2 m	
CABLE SECTION	2 x 0,35 mm ²	
HOUSING MATERIAL	Housing: nickel-plated brass - Lenses: methacrylate	
WEIGHT - cable output	120 g	

(1) Determined with a white mat paper (cm 10 x 10).
 (2) Determined with a white mat paper (cm 20 x 20).
 (3) Determined with halogen tungsten lamp 3000 °K.
 Note: for a proper use see norms at pages 18, 19, 20, 21 and 22.

WIRING DIAGRAMS

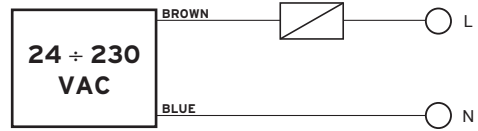

WARNING: Short circuit in the output is not possible. Wrong supply cables connections can irreparably damage the detector. Therefore sensors whose output status is short-circuited will not be substituted under warranty.

CONNECTION WITH CONNECTOR M12 (K)

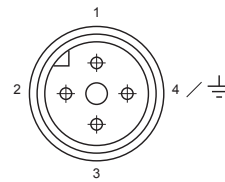

View of quadripole male connector.

CONTACTS CONFIGURATION

Output	Contacts numbers			
	1	2	3	4
(NO or NC)	L		N	

ACCESSORIES

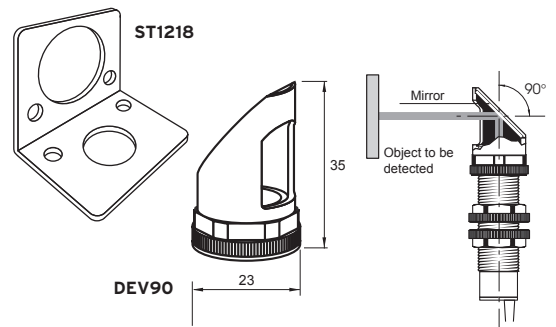

DIMENSIONS (mm)

Configuration with cable

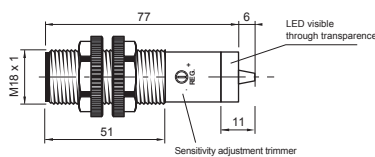

Configuration with cable - Back view

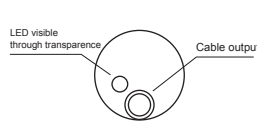

Configuration with connector K

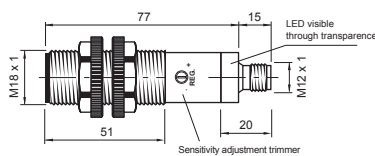

Configuration with connector K Back view

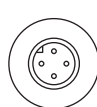

Note: the trimmer just needs one turn.

CHARACTERISTIC CURVES

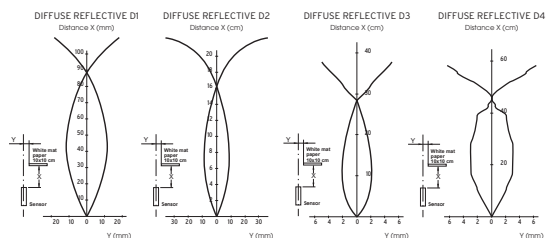



PHOTOELECTRIC SENSORS

DIFFUSE REFLECTIVE 12÷30 V DC - NPN/PNP OUTPUT

- 18mm tubular in metal housing
- Programmable output, NPN or PNP, NC + NO
- Simple one-turn sensitivity
- Cable or M12 quick connect models
- Fast response time: 2 ms / 0,5 ms/1KHz
- Long working distances
- Device marking II 3D

MD Series



IDENTIFICATION CODE

MD 01 A D3 K

SERIES MD

DIFFUSE REFLECTIVE

NPN NO+NC output

PNP NO+NC output

Switching distance = 0 ÷ 40 cm

Switching distance = 0 ÷ 70 cm

A

B

D3

D4

CONNECTOR OUTPUT M12

AVAILABLE	D3	D4
NOMINAL SWITCHING DISTANCE (Sn)	0 ÷ 40 cm ⁽¹⁾	0 ÷ 70 cm ⁽²⁾
TOLERANCE	+ 10 / - 10 % Sn	
HYSTERESIS	< 10%	
EMISSION	Infrared (880 nm)	
NOMINAL VOLTAGE	10 ÷ 30 VDC	
RESIDUAL RIPPLE	≤ 2 Vpp	
MAX. OUTPUT CURRENT	100 mA	
CONSUMPTION	≤ 35 mA	
VOLTAGE DROP	≤ 2 V	
STATUS LED	Yellow	
STABILITY LED	Green	
SENSITIVITY ADJUSTMENT	Single turn trimmer	
SWITCHING FREQUENCY	1 kHz	
RESPONSE TIME	0,5 ms	
START UP DELAY	≤ 300 ms	
SHORT CIRCUIT PROTECTION	Present (Self resetting)	
ELECTRIC PROTECTIONS	Reverse polarity protection	
TEMPERATURE LIMITS	-25 ÷ +55 °C	
LIGHT IMMUNITY	> 5.000 Lux ⁽³⁾	
PROTECTION DEGREE	IP67	
CABLE LENGTH	2m	
CABLE SECTION	4 x 0.14 mm ²	
HOUSING MATERIAL	Housing: nickel plated brass Lenses: PMMA	
WEIGHT - cable output - (connector output)	110g (60g)	

⁽¹⁾ Determined with a white mat paper (cm 10 x 10).

⁽²⁾ Determined with a white mat paper (cm 20 x 20).

⁽³⁾ Determined with halogen tungsten lamp 3000 °K.

Note: for a proper use see norms at pages 18, 19, 20, 21 and 22.

WIRING DIAGRAMS

View of quadriple male connector

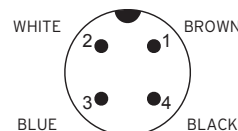

CONTACTS CONFIGURATION

	Contacts numbers			
	1	2	3	4
Output	+	NC	-	NO

DETECTION DIAGRAM

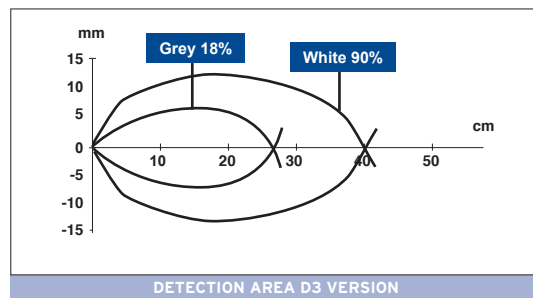
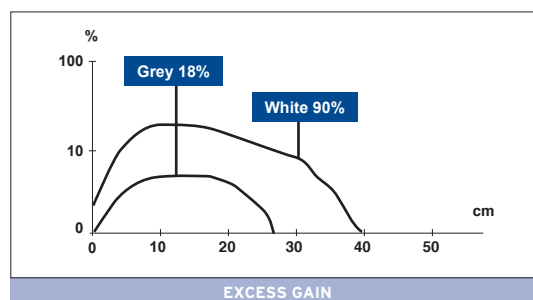

DIMENSIONS (mm)

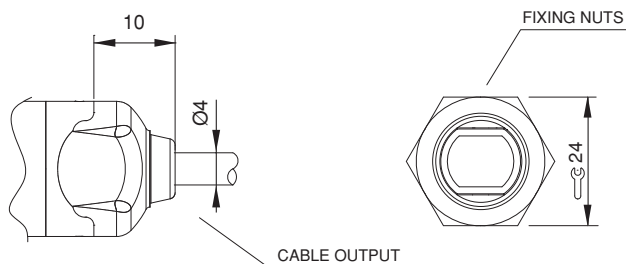
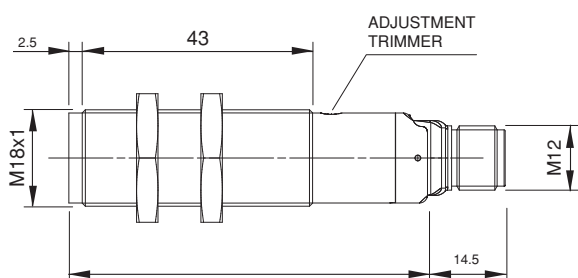



PHOTOELECTRIC SENSORS

RETRO REFLECTIVE 12÷30 V DC - NPN OR PNP OUTPUT

- 18mm tubular in metal housing
- Operation LED visible laterally and at the back
- Cable or M12 quick connect models
- Long working distances
- Fast response time: 1 ms/500 Hz

18 Series



IDENTIFICATION CODE

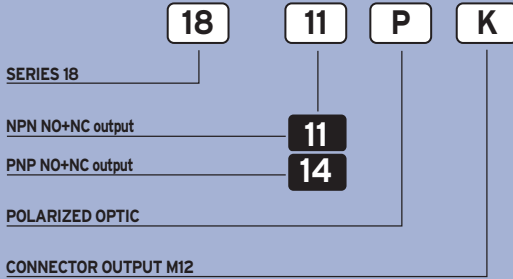

AVAILABLE	POLARIZED	STANDARD
NOMINAL SWITCHING DISTANCE (Sn)	2 m ⁽¹⁾	6 m ⁽¹⁾
TOLERANCE	+10/-10 %Sn	
HYSTERESIS	10%	
EMISSION	Red (660 nm)	Infrared (875 nm)
NOMINAL VOLTAGE	12 ÷ 30VDC (-15 /+10%)	
RESIDUAL RIPPLE	10%	
MAX. OUTPUT CURRENT	200 mA	
ABSORPTION AT 30 VDC	40 mA	
VOLTAGE DROP (Sensor ON)	1.5V (I = 200 mA)	
OPERATION LED	Yellow	
SWITCHING FREQUENCY	500 Hz	
RESPONSE TIME	1 ms	
START UP DELAY	200 ms	
SHORT CIRCUIT PROTECTION	Present (self-resetting)	
ELECTRIC PROTECTIONS	Against polarity reversal - inductive loads	
TEMPERATURE LIMITS	-10 ÷ +60 °C	
LIGHT IMMUNITY	10.000 Lux ⁽²⁾	
PROTECTION DEGREE	IP 67	
CABLE LENGTH	2 m	
CABLE SECTION	3 x 0.25 mm ²	
HOUSING MATERIAL	Nickel-plated brass	
WEIGHT - cable output - (connector output)	- 110 g - (55 g)	

⁽¹⁾ Determined with CTO4S reflector.

⁽²⁾ Determined with halogen tungsten lamp 3000 °K.

Note: for a proper use see norms at pages 18, 19, 20, 21 and 22.

WIRING DIAGRAMS

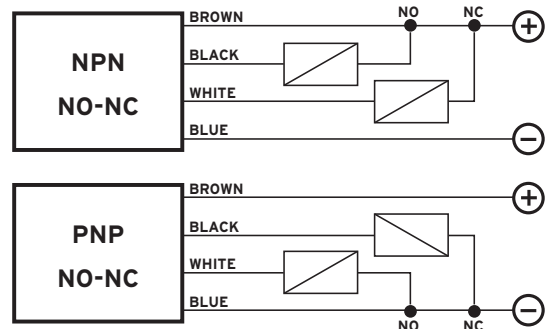

CONNECTION WITH CONNECTOR M12 (K)

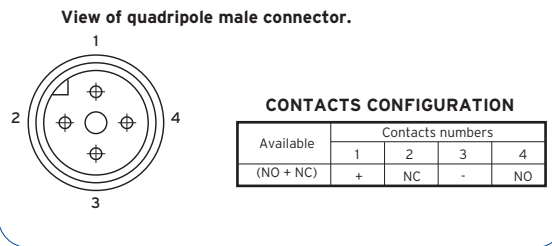

ACCESSORIES

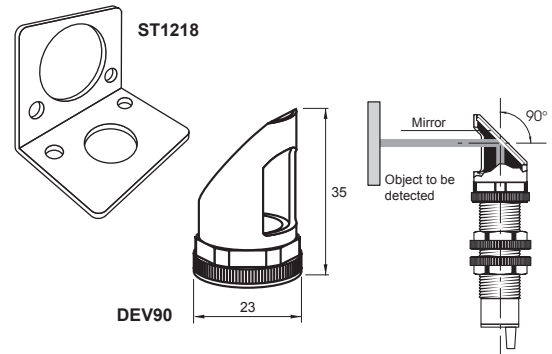

DIMENSIONS (mm)

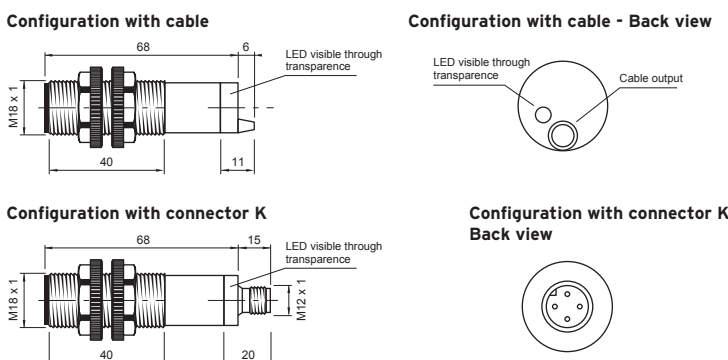

CHARACTERISTIC CURVES

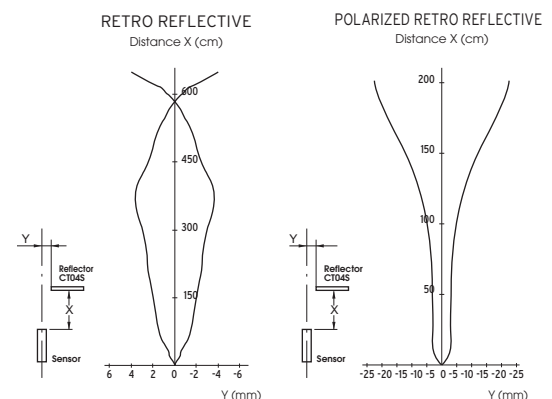

PHOTOELECTRIC



PHOTOELECTRIC SENSORS

RETRO REFLECTIVE 24÷230 V AC TRIAC NO AND NC OUTPUT

- 18mm tubular in plastic housing
- Leakage <1.5 mA @ 220 V AC
- Cable or M12 quick connect models
- Models with 9-turn pot
- Models with connector in metal housing



18 Series



IDENTIFICATION CODE

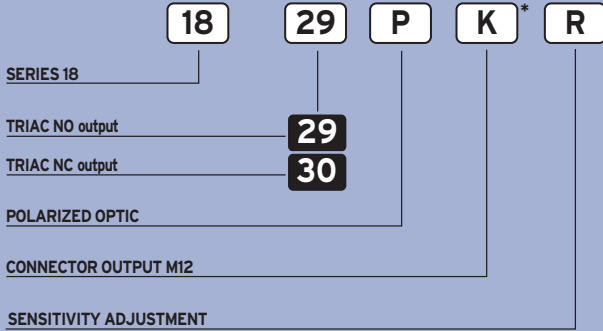

* "K" model available only in metal housing.

AVAILABLE	POLARIZED	STANDARD
NOMINAL SWITCHING DISTANCE (Sn)	1 m ⁽¹⁾	3 m ⁽¹⁾
TOLERANCE	+10/-10 %Sn	
HYSTERESIS	10%	
EMISSION	Red (660 nm)	Infrared (875 nm)
NOMINAL VOLTAGE	24 ÷ 230VAC (-15 /+10%)	
MAINS FREQUENCY	50 ÷ 60 Hz	
MAX. OUTPUT CURRENT	150 mA	
LEAKAGE CURRENT	1.5mA (at 220VAC)	
ABSORPTION	1 W	
VOLTAGE DROP (Sensor ON)	< 2.5 V	
OPERATION LED	Yellow	
SWITCHING FREQUENCY	10 Hz	
RESPONSE TIME	50 ms	
START UP DELAY	300 ms	
ELECTRIC PROTECTIONS	Against inductive loads	
TEMPERATURE LIMITS	-10 ÷ +60 °C	
LIGHT IMMUNITY	5.000 Lux ⁽²⁾	
PROTECTION DEGREE	IP 67 (IP 65 for models with sensitivity adjustment)	
CABLE LENGTH	2 m	
CABLE SECTION	3 x 0.35 mm ²	
HOUSING MATERIAL	Housing: plastic / nickel-plated brass - Lenses: methacrylate	
WEIGHT - cable output -	120 g	

⁽¹⁾ Determined with CTO4S reflector.

⁽²⁾ Determined with halogen tungsten lamp 3000 °K.

Note: for a proper use see norms at pages 18, 19, 20, 21 and 22.

WIRING DIAGRAMS

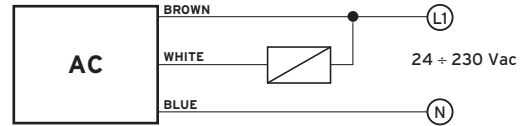

WARNING: Short circuit in the output is not possible. Wrong supply cables connections can irreparably damage the detector. Therefore sensors whose output status is short-circuited will not be substituted under warranty.

CONNECTION WITH CONNECTOR M12 (K)

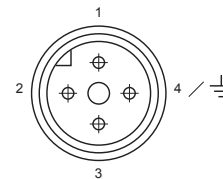

View of quadrupole male connector.

CONTACTS CONFIGURATION

Output	Contacts numbers			
	1	2	3	4
(NO or NC)	L		N	NO/NC

CONNECTIONS IN PARALLEL

In parallel connections with multiple outputs, the maximum leakage current (<1,5 mA at 220 VAC) referring to the load and the supply should be taken into account when calculating the max. quantity of connectable sensors. It is important in this connection that the sensors are connected at the same phase.

ACCESSORIES

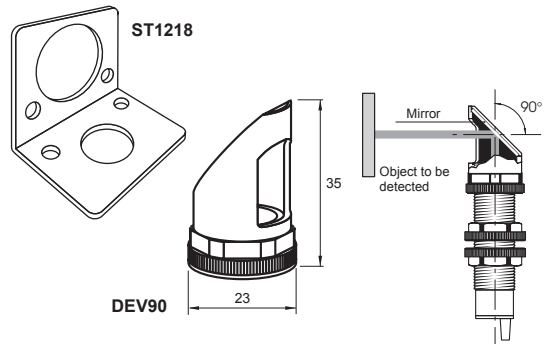

DIMENSIONS (mm)

Configuration with cable

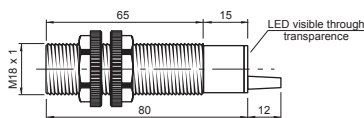

Configuration with cable - Back view

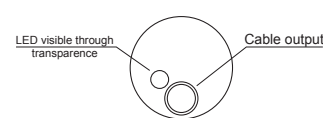

Configuration with connector K (metal housing)

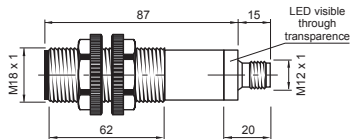

Configuration with sensitivity adjustment

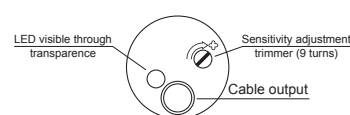

CHARACTERISTIC CURVES

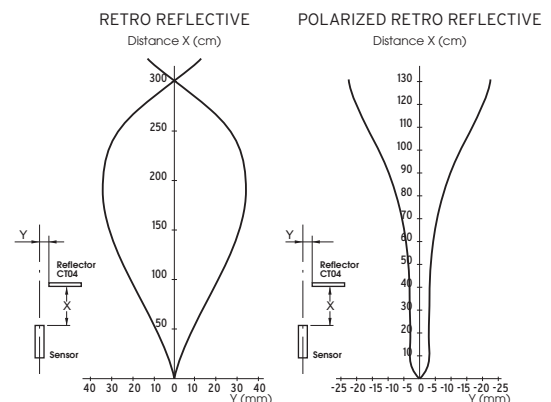

PHOTOELECTRIC SENSORS



RETRO REFLECTIVE 24÷230 V AC - 2 WIRES

- 18mm tubular in metal housing
- Leakage Typ. 2,5 mA @ 230 V AC
- Models w/o post for simple installation
- Cable or M12 quick connect models

18 Series



IDENTIFICATION CODE

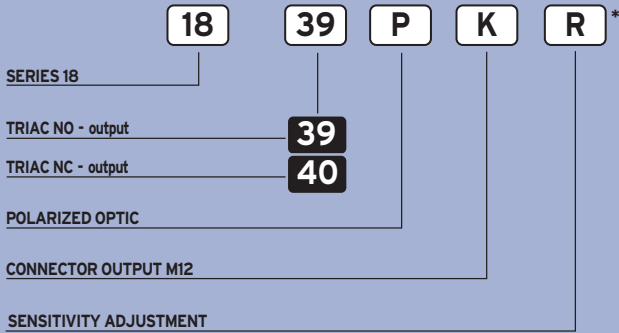

* All models available only with R sensitivity adjustment

AVAILABLE	POLARIZED	STANDARD
NOMINAL SWITCHING DISTANCE (Sn)	1 m	3 m
TOLERANCE	+10/-10%Sn	
HYSTERESIS	3-20%	
EMISSION	Infrared (875 nm)	
NOMINAL VOLTAGE	24 ÷ 230VAC (-15 / +10%)	
MAINS FREQUENCY	50 ÷ 60 Hz	
MAX. OUTPUT CURRENT	500 mA	
LEAKAGE CURRENT (at 230 VAC)	5mA (Typ. 2,5mA)	
VOLTAGE DROP (Sensor ON)	< 10 (Typ. 7) VAC	
OPERATION LED	Yellow	
SWITCHING FREQUENCY	20 Hz	
RESPONSE TIME	Ton<=20mS-Toff<=30ms	
START UP DELAY	Typ. 100 ms	
TEMPERATURE LIMITS	-10 ÷ +60 °C	
LIGHT IMMUNITY	5000 Lux ⁽³⁾	
PROTECTION DEGREE	IP 67	
CABLE LENGTH	2 m	
CABLE SECTION	2 x 0.35 mm ²	
HOUSING MATERIAL	Housing: nickel-plated brass - Lenses: methacrylate	
WEIGHT - cable output	120 g	

(1) Determined with a white mat paper (cm 10 x 10).
 (2) Determined with a white mat paper (cm 20 x 20).
 (3) Determined with halogen tungsten lamp 3000 °K.
 Note: for a proper use see norms at pages 18, 19, 20, 21 and 22.

WIRING DIAGRAMS

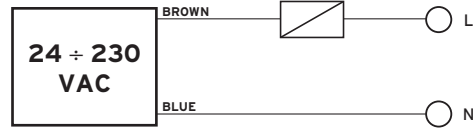

WARNING: Short circuit in the output is not possible. Wrong supply cables connections can irreparably damage the detector. Therefore sensors whose output status is short-circuited will not be substituted under warranty.

CONNECTION WITH CONNECTOR M12 (K)

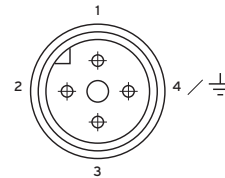

View of quadrupole male connector.

CONTACTS CONFIGURATION

Output (NO or NC)	Contacts numbers			
	1	2	3	4
L			N	

ACCESSORIES

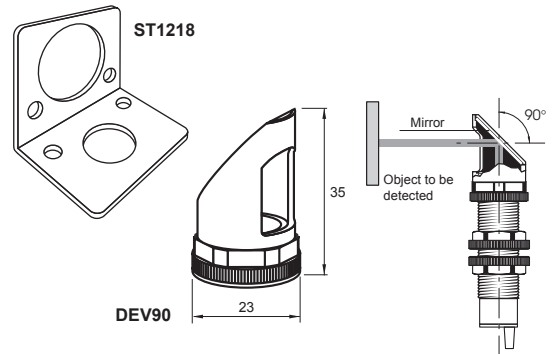

DIMENSIONS (mm)

Configuration with cable

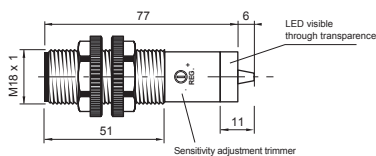

Configuration with cable - Back view

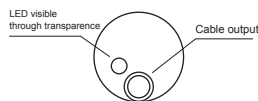

Configuration with connector K

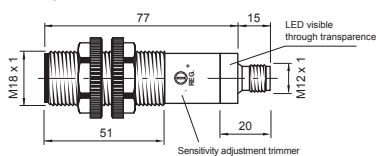

Configuration with connector K Back view



Note: the trimmer just needs one turn.

CHARACTERISTIC CURVES

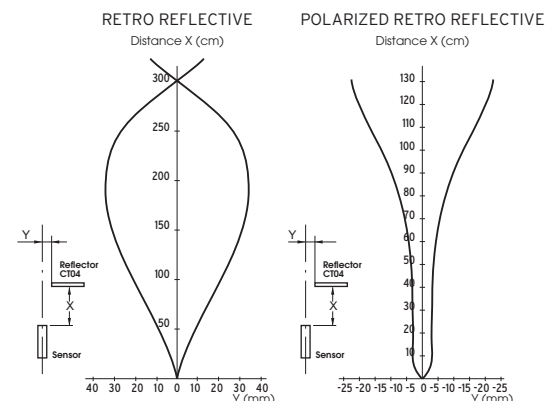



PHOTOELECTRIC SENSORS



RETRO REFLECTIVE 12÷30 V DC NPN/PNP OUTPUT

- 18mm tubular in metal housing
- Programmable output, NPN/PNP, NC + NO
- Simple one-turn sensitivity
- Cable or M12 quick connect models
- Fast response time: 2 ms / 0,5 ms/1KHz
- Long working distance
- Device marking II 3D

MD Series



IDENTIFICATION CODE

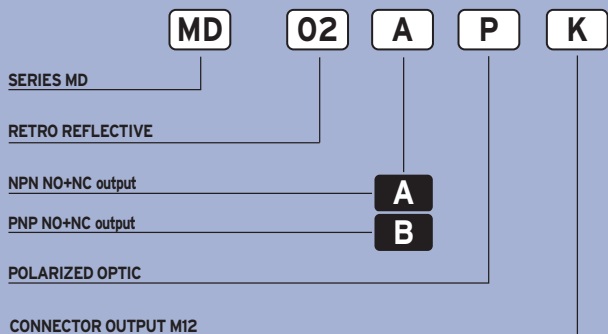

AVAILABLE	POLARIZED	STANDARD
NOMINAL SWITCHING DISTANCE (Sn)	0.1 ÷ 4.5 m ⁽¹⁾	0.1 ÷ 5 m ⁽²⁾
TOLERANCE	+ 10 / -10 % Sn	
HYSTERESIS	<10%	
EMISSION	Infrared (880 nm)	
NOMINAL VOLTAGE	10 ÷ 30 VDC	
RESIDUAL RIPPLE	≤ 2 Vpp	
MAX. OUTPUT CURRENT	100 mA	
CONSUMPTION	≤ 35 mA	
VOLTAGE DROP	≤ 2 V	
STATUS LED	Yellow	
STABILITY LED	Green	Not present
SENSITIVITY ADJUSTMENT	Single turn trimmer	Not present
SWITCHING FREQUENCY	1 kHz	
RESPONSE TIME	0.5 ms	
START UP DELAY	≤ 300 ms	
SHORT CIRCUIT PROTECTION	Present (Self resetting)	
ELECTRIC PROTECTIONS	Reverse polarity protection	
TEMPERATURE LIMITS	-25 ÷ +55 °C	
LIGHT IMMUNITY	> 5.000 Lux ⁽³⁾	
PROTECTION DEGREE	IP67	
CABLE LENGTH	2m	
CABLE SECTION	4 x 0.14 mm ²	
HOUSING MATERIAL	Housing: nickel plated brass Lenses: PMMA	
WEIGHT - cable output - (connector output)	110g (60g)	

⁽¹⁾ Determined with a white mat paper (cm 10 x 10).

⁽²⁾ Determined with a white mat paper (cm 20 x 20).

⁽³⁾ Determined with halogen tungsten lamp 3000 °K.

Note: for a proper use see norms at pages 18, 19, 20, 21 and 22.

WIRING DIAGRAMS

View of quadriple male connector

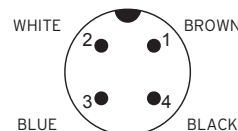

CONTACTS CONFIGURATION

	Contacts numbers			
	1	2	3	4
Output	+	NC	-	NO

DETECTION DIAGRAM

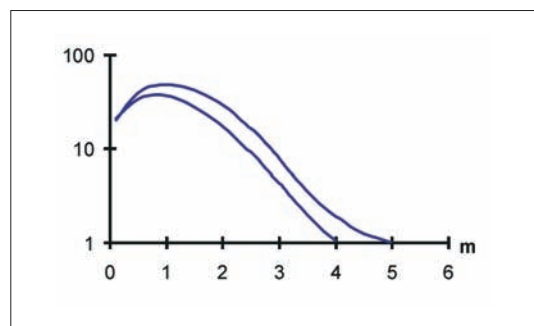

EXCESS GAIN

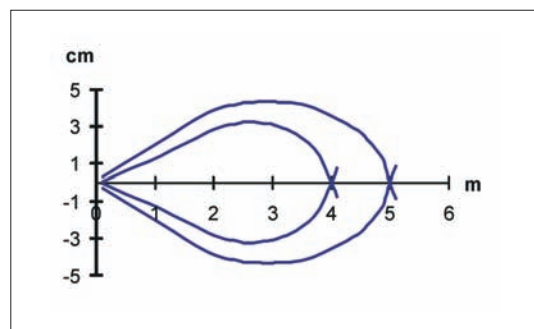

DETECTION AREA

PHOTOELECTRIC

DIMENSIONS (mm)

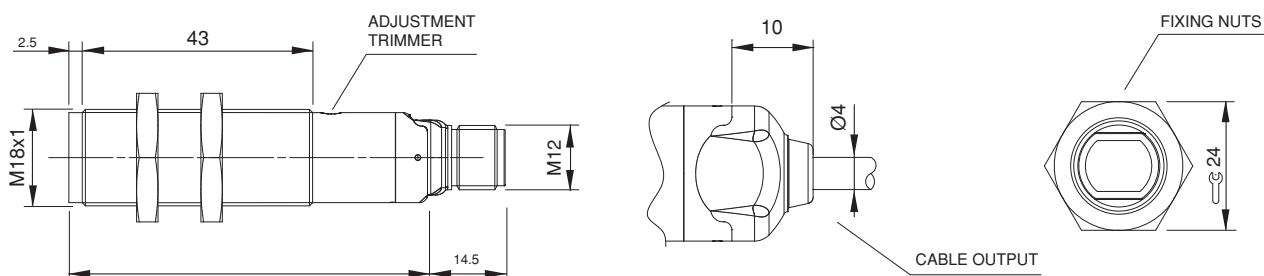

PHOTOELECTRIC SENSORS



THRU BEAM

12÷30 V DC - NPN OR PNP OUTPUT

- 18mm tubular in metal housing
- Operation LED aids installation
- Cable or M12 quick connect models
- Emitter with test input

18 Series



IDENTIFICATION CODE

18 **22** **K** **T** * **EX** ⁽²⁾

SERIES 18

NPN NO output

22

NPN NC output

23

PNP NO output

24

PNP NC output

25

Emitter

21

CONNECTOR OUTPUT M12

TEST INPUT

ATEX GROUP II CAT. 3D

* Option valid only for code 1821

AVAILABLE	RECEIVER	EMITTER
NOMINAL SWITCHING DISTANCE (Sn)	25 m	
TOLERANCE	+10/-10 %Sn	
HYSTERESIS	10%	
EMISSION	-	Infrared (875 nm)
NOMINAL VOLTAGE	12 ÷ 30VDC (-15 /+10%)	
RESIDUAL RIPPLE	10%	
MAX. OUTPUT CURRENT	200 mA	-
ABSORPTION AT 30 VDC	15 mA	
VOLTAGE DROP (Sensor ON)	1.5V (I = 200 mA)	-
OPERATION LED	Yellow	
SWITCHING FREQUENCY	200 Hz	
RESPONSE TIME	2.5 ms	
START UP DELAY	100 ms	
SHORT CIRCUIT PROTECTION	Present (self-resetting)	
ELECTRIC PROTECTIONS	Against polarity reversal - inductive loads	
TEMPERATURE LIMITS	-10 ÷ +60 °C	
LIGHT IMMUNITY	> 10000 Lux ⁽¹⁾	
PROTECTION DEGREE	IP 67 (IP 65 for models with sensitivity adjustment)	
CABLE LENGTH	2 m	
CABLE SECTION	3 x 0.25 mm ²	3/2 x 0.25 mm ²
HOUSING MATERIAL	Housing: nickel plated brass - Lenses: methacrylate	
WEIGHT - cable output - (connector output)	- 110 g - (55 g)	

⁽¹⁾ Determined with halogen tungsten lamp 3000 °K.

⁽²⁾ Device marking II 3D IP67 T6X.

Note: for a proper use see norms at pages 18, 19, 20, 21 and 22.

WIRING DIAGRAMS

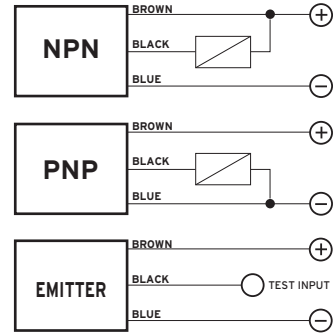

CONNECTION WITH CONNECTOR M12 (K)

View of quadriple male connector.

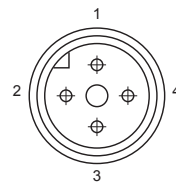

CONTACTS CONFIGURATION

Available	Contacts numbers			
	1	2	3	4
(NO o NC)	+	-	-	NO/NC
Emitter	+	-	-	TEST

ACCESSORIES

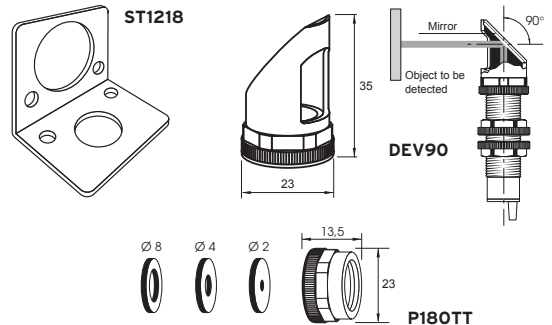

DIMENSIONS (mm)

Configuration with cable

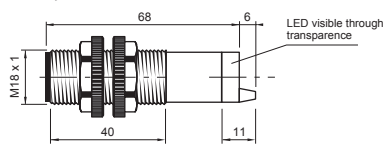

Configuration with cable - Back view

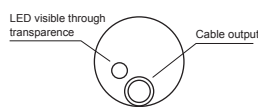

Configuration with connector K

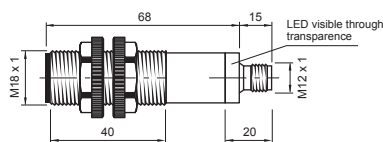

Configuration with connector K Back view



CHARACTERISTIC CURVES

THRU BEAM
Distance X (m)

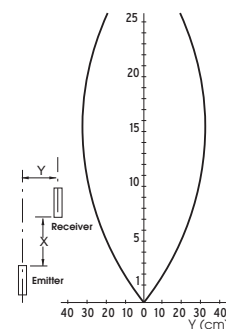



PHOTOELECTRIC SENSORS

THRU BEAM

24÷230 V AC - TRIAC NO AND NC OUTPUT

- 18mm tubular in metal housing
- Leakage <1.5 mA @ 220 V AC
- Cable or M12 quick connect models



18 Series



IDENTIFICATION CODE

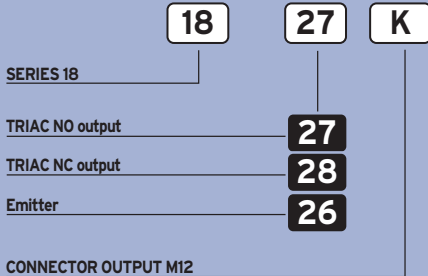

AVAILABLE	RECEIVER	EMITTER
NOMINAL SWITCHING DISTANCE (Sn)	5 m	
TOLERANCE	+10/-10 %Sn	
HYSTERESIS	10%	
EMISSION	-	Infrared (875 nm)
NOMINAL VOLTAGE	24 ÷ 230VAC (-15 /+10%)	
MAINS FREQUENCY	50 ÷ 60 Hz	
MAX. OUTPUT CURRENT	150 mA	-
LEAKAGE CURRENT	1.5mA (at 220VAC)	-
ABSORPTION	1 W	-
VOLTAGE DROP (Sensor ON)	< 2.5 V	
OPERATION LED	Yellow	
SWITCHING FREQUENCY	10 Hz	
RESPONSE TIME	50 ms	
START UP DELAY	300 ms	
ELECTRIC PROTECTIONS	Against inductive loads	
TEMPERATURE LIMITS	-10 ÷ +60 °C	
LIGHT IMMUNITY	2000 Lux ⁽¹⁾	
PROTECTION DEGREE	IP 67 (IP 65 for models with sensitivity adjustment)	
CABLE LENGTH	2 m	
CABLE SECTION	3 x 0.35 mm ²	2 x 0.25 mm ²
HOUSING MATERIAL	Housing: nickel-plated brass - Lenses: methacrylate	
WEIGHT - cable output -	120 g	

⁽¹⁾ Determined with halogen tungsten lamp 3000 °K.
Note: for a proper use see norms at pages 18, 19, 20, 21 and 22.

WIRING DIAGRAMS

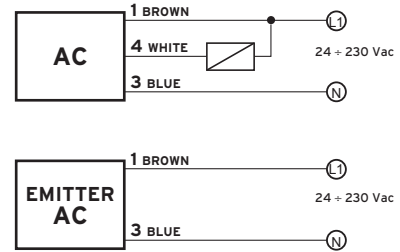

WARNING: Short circuit in the output is not possible. Wrong supply cables connections can irreparably damage the detector. Therefore sensors whose output status is short-circuited will not be substituted under warranty.

CONNECTIONS IN PARALLEL: In parallel connections with multiple outputs, the maximum leakage current (<1,5 mA at 220 VAC) referring to the load and the supply should be taken into account when calculating the max. quantity of connectable sensors. It is important in this connection that the sensors are connected at the same phase.

ACCESSORIES

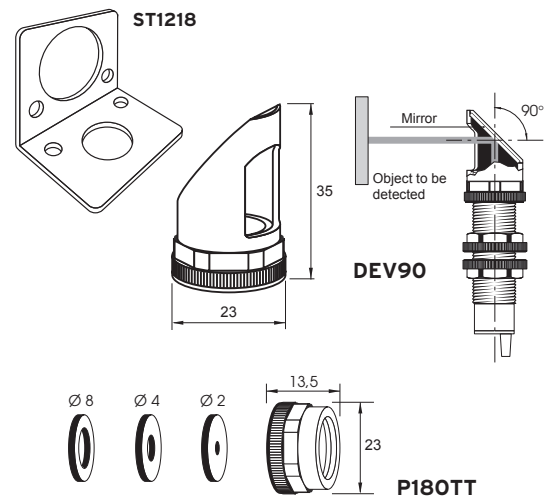

DIMENSIONS (mm)

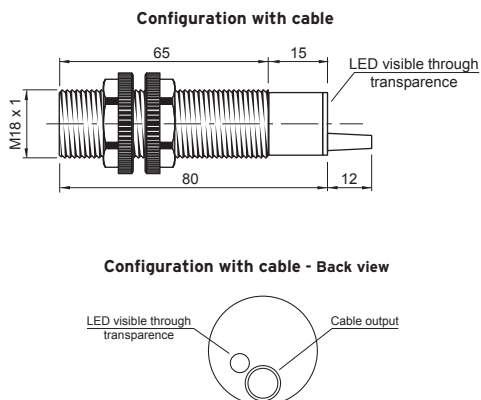

CHARACTERISTIC CURVES

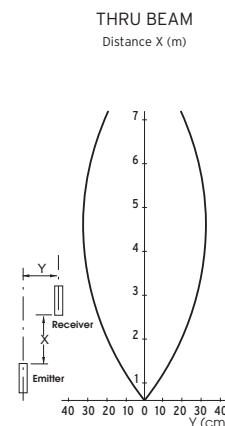



PHOTOELECTRIC SENSORS



DIFFUSE REFLECTIVE 12÷30 V DC - NPN OR PNP OUTPUT

- Miniature housing
- Sensitivity adjustment
- Yellow LED - output indicator
- Green LED - stability indicator
- M8 connector output 4 poles

MT Series



IDENTIFICATION CODE

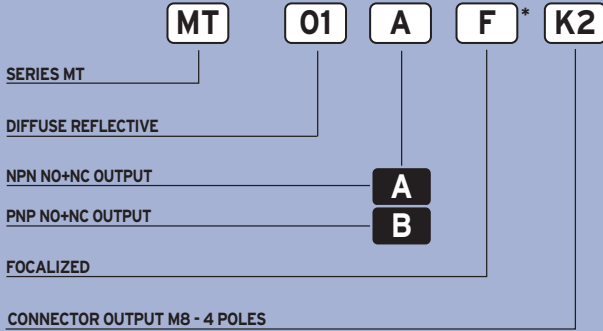

* Without sensitivity adjustment

AVAILABLE	DIFFUSE REFLECTIVE	FOCALIZED
NOMINAL SWITCHING DISTANCE (S _n)	0,2 - 35 cm ⁽¹⁾	11 cm ⁽¹⁾
HOUSING MATERIAL	ABS	
OPERATING VOLTAGE	10 ÷ 30 VDC	
RESIDUAL RIPPLE	< 2Vpp	
ABSORPTION	< 35mA	
EMISSION	Infrared led 880 nm	Red LED 660 nm
MAX. OUTPUT CURRENT	100 mA	
VOLTAGE DROP	< 2V	
SWITCHING FREQUENCY	500 Hz	
RESPONSE TIME	1 ms	
SENSITIVITY ADJUSTMENT	Present	-
LED	Present	
LIGHT IMMUNITY	> 5000 Lux ⁽²⁾	
PROTECTION DEGREE	IP 66	
TEMPERATURE LIMITS	-25/+55 °C	
REVERSE POLARITY PROTECTION	Present	
SHORT CIRCUIT PROTECTION	Present	
START UP DELAY	< 300 ms	
CONNECTION	M8 Connector (4 poles)	
WEIGHT	26 g	

⁽¹⁾ Determined with a white mat paper (cm 10 x 10).

⁽²⁾ Determined with halogen tungsten lamp 3000 °K.

Note: for a proper use see norms at pages 18, 19, 20, 21 and 22.

WIRING DIAGRAMS

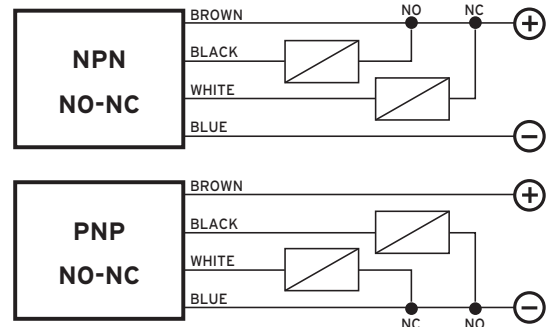

CONNECTION WITH CONNECTOR M8 (K)

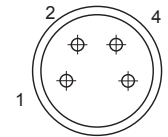

View of quadripole male connector

CONTACTS CONFIGURATION

Output	Contacts numbers			
	1	2	3	4
NPN/PNP NO+NC	+	NC	-	NO

SENSITIVITY ADJUSTMENT

- 1) **SENSITIVITY INCREASE**
Screw the trimmer towards right towards position "+"
- 2) **SENSITIVITY DECREASE**
Screw the trimmer towards left towards position "-"

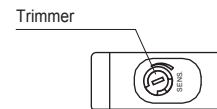

Note: the trimmer just needs one turn.

DIMENSIONS (mm)

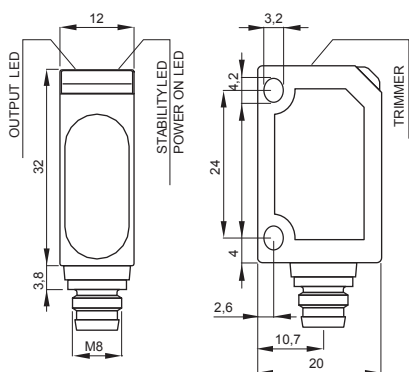

CHARACTERISTIC CURVES

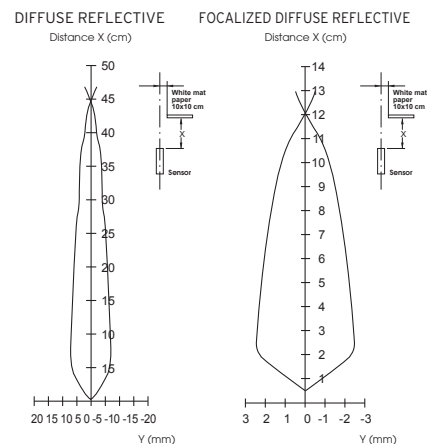



PHOTOELECTRIC SENSORS



RETRO REFLECTIVE 12÷30 V DC NPN OR PNP OUTPUT

- Miniature housing
- Sensitivity adjustment
- Yellow LED - output indicator
- Green LED - stability indicator
- M8 connector output 4 poles
- Version for transparent

MT Series



IDENTIFICATION CODE

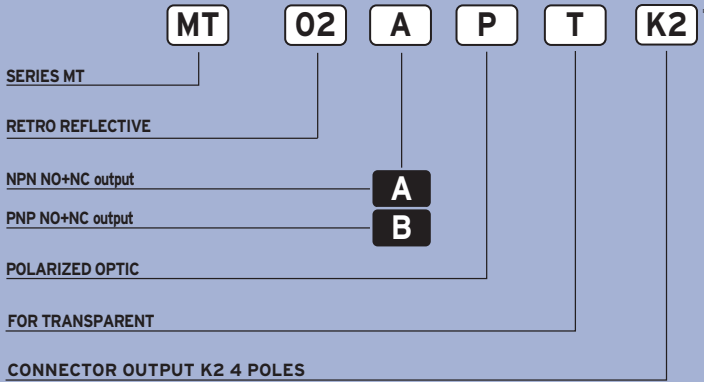

* Available only with K2 (M8 4 poles connector)

AVAILABLE	POLARIZED RETROREFLECTIVE	POLARIZED RETROREFLECTIVE FOR TRANSPARENT
NOMINAL SWITCHING DISTANCE (Sn)	2 m ⁽¹⁾	0,1 ÷ 0,7 m ⁽¹⁾
HOUSING MATERIAL	ABS	
OPERATING VOLTAGE	10-30 VDC	
RESIDUAL RIPPLE	< 2Vpp	
ABSORPTION	< 35mA	
EMISSION	Red led 660 nm	Infrared LED 880 nm
MAX. OUTPUT CURRENT	100 mA	
VOLTAGE DROP	< 2V	
SWITCHING FREQUENCY	500 Hz	
RESPONSE TIME	1 ms	
SENSITIVITY ADJUSTMENT	Present	
LED	Present	
LIGHT IMMUNITY	> 5000 Lux ⁽²⁾	
PROTECTION DEGREE	IP 66	
TEMPERATURE LIMITS	-25/+55°C	
REVERSE POLARITY PROTECTION	Present	
SHORT CIRCUIT PROTECTION	Present	
START UP DELAY	< 300 ms	
CONNECTION	M8 Connector (4 poles)	
WEIGHT	26 g	

⁽¹⁾ Determined with CT04S reflector.
⁽²⁾ Determined with halogen tungsten lamp 3000 °K.
 Note: for a proper use see norms at pages 18, 19, 20, 21 and 22.

WIRING DIAGRAMS

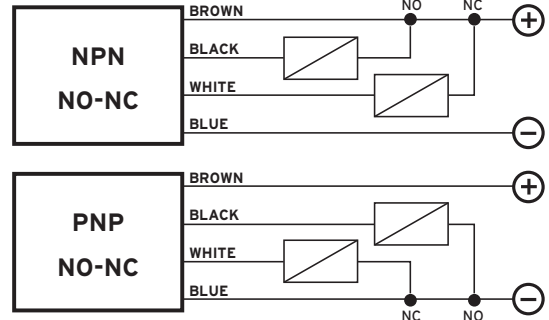

CONNECTION WITH CONNECTOR M8 (K2)

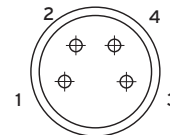

View of quadripole male connector

CONTACTS CONFIGURATION

Output	Contacts numbers			
	1	2	3	4
NPN/PNP NO+NC	+	NC	-	NO

SENSITIVITY ADJUSTMENT

- 1) SENSITIVITY INCREASE**
Screw the trimmer towards right towards position "+"
- 2) SENSITIVITY DECREASE**
Screw the trimmer towards left towards position "--"

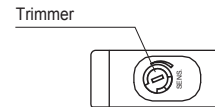

Note: the trimmer just needs one turn.

DIMENSIONS (mm)

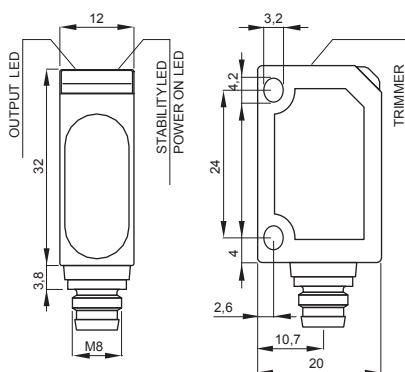

CHARACTERISTIC CURVES

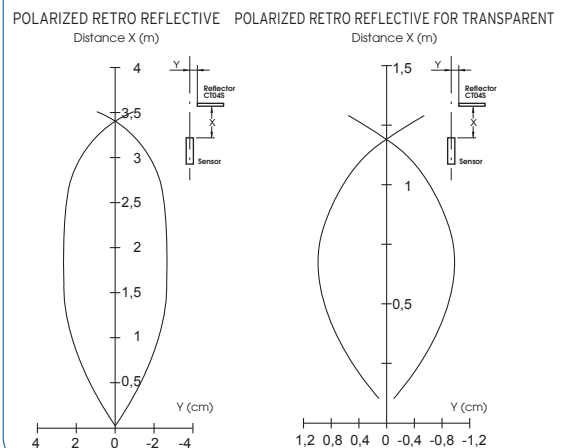



PHOTOELECTRIC SENSORS



THRU BEAM

12÷30 V DC - NPN OR PNP OUTPUT

- Miniature housing
- Sensitivity adjustment
- Yellow LED - output indicator
- Green LED - stability indicator
- M8 connector output 4 poles

MT Series



IDENTIFICATION CODE

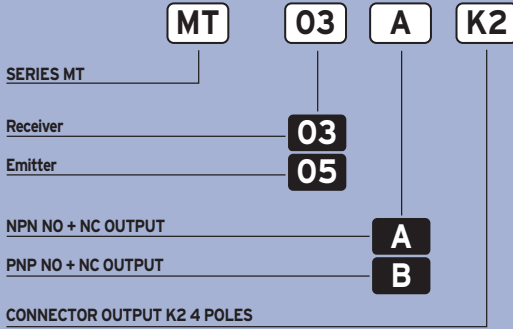

AVAILABLE	RECEIVER	EMITTER
NOMINAL SWITCHING DISTANCE (Sn)	0,1 m...6 m	
HOUSING MATERIAL	ABS	
OPERATING VOLTAGE	10-30 VDC	
RESIDUAL RIPPLE	< 2Vpp	
ABSORPTION	< 35mA	
EMISSION	-	Infrared led 880 nm
MAX. OUTPUT CURRENT	100 mA	-
VOLTAGE DROP	< 2V	-
SWITCHING FREQUENCY	500 Hz	
RESPONSE TIME	1 ms	
SENSITIVITY ADJUSTMENT	Present	-
LED	Present	
LIGHT IMMUNITY	> 5000 Lux ⁽¹⁾	
PROTECTION DEGREE	IP 66	
TEMPERATURE LIMITS	-25/+55 °C	
REVERSE POLARITY PROTECTION	Present	
SHORT CIRCUIT PROTECTION	Present	-
START UP DELAY	< 300 ms	
CONNECTION	M8 Connector (4 poles)	
WEIGHT	26 g	

⁽¹⁾ Determined with halogen tungsten lamp 3000 °K.
 Note: for a proper use see norms at pages 18, 19, 20, 21 and 22.

WIRING DIAGRAMS

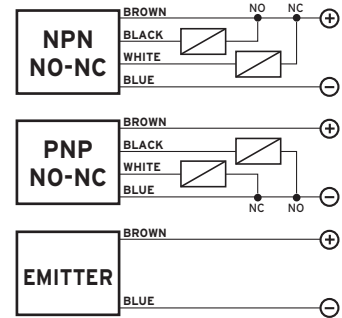

CONNECTION WITH CONNECTOR M8 (K2)

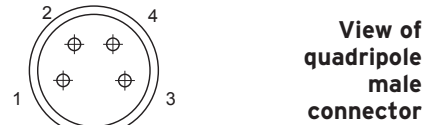

CONTACTS CONFIGURATION

Output	Contacts numbers			
	1	2	3	4
NPN/PNP NO+NC	+	NC	-	NO
EMITTER	+		-	

SENSITIVITY ADJUSTMENT

- 1) SENSITIVITY INCREASE**
Screw the trimmer towards right towards position "+"
- 2) SENSITIVITY DECREASE**
Screw the trimmer towards left towards position "-"

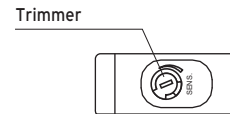

Note: the trimmer just needs one turn.

DIMENSIONS (mm)

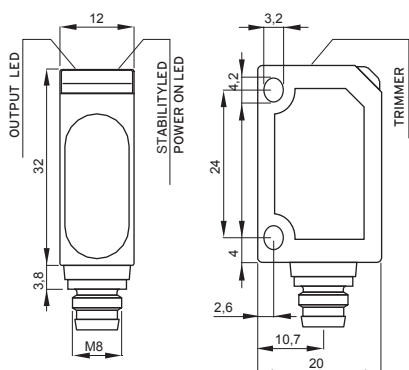

CHARACTERISTIC CURVES

EMITTER RECEIVER THRU BEAM
 Distance X (m)

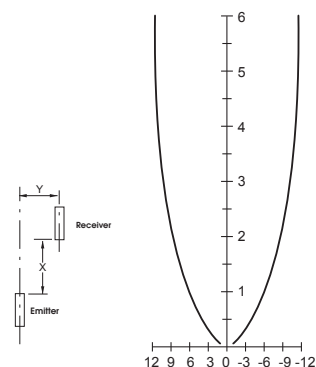

PHOTOELECTRIC

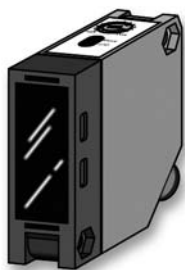

PHOTOELECTRIC SENSORS



DIFFUSE REFLECTIVE 12 ÷ 30 V DC - PROGRAMMABLE OUTPUT

- Square housing
- Compact size, output and supply indicators
- Cost effective
- Cable or M12 quick connect models
- Fast response time: 2.5 ms ON/OFF

FQ Series



IDENTIFICATION CODE

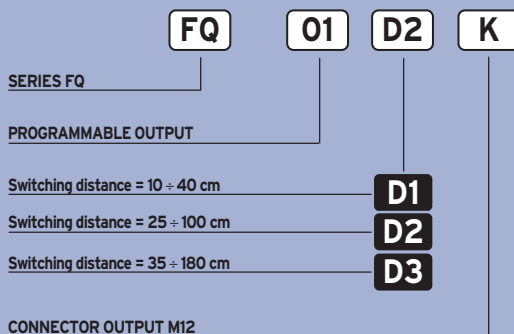

AVAILABLE	D1	D2	D3
NOMINAL SWITCHING DISTANCE (Sn)	10...40 cm ⁽¹⁾	25...100 cm ⁽¹⁾	35...180 cm ⁽²⁾
TOLERANCE	+10/-10 %Sn		
HYSTERESIS	10%		
EMISSION	Infrared (875 nm)		
NOMINAL VOLTAGE	12 ÷ 30VDC (-15 /+10%)		
RESIDUAL RIPPLE	10%		
OUTPUT	NPN or PNP (programmable)		
CONTACT	NO or NC (programmable)		
MAX. OUTPUT CURRENT	200 mA		
ABSORPTION AT 30 VDC	40 mA		
VOLTAGE DROP (Sensor ON)	1.8 V (I = 100 mA)		
YELLOW LED	Output indicator		
GREEN LED	Supply indicator		
SENSITIVITY ADJUSTMENT	Trimmer 1 turn		
SWITCHING FREQUENCY	200 Hz		
RESPONSE TIME	2.5 ms		
START UP DELAY	100 ms		
SHORT CIRCUIT PROTECTION	Present (self-resetting)		
ELECTRIC PROTECTIONS	Against polarity reversal - inductive loads		
TEMPERATURE LIMITS	-10 ÷ +60 °C		
LIGHT IMMUNITY	> 10.000 Lux ⁽³⁾		
PROTECTION DEGREE	IP 65		
CABLE LENGTH	2 m		
CABLE SECTION	4 x 0.25 mm ²		
HOUSING MATERIAL	Housing: ABS - Lenses: methacrylate		
WEIGHT - cable output - (connector output)	- 160 g - (120 g)		

⁽¹⁾ Determined with a white mat paper (cm 10 x 10).
⁽²⁾ Determined with a white mat paper (cm 20 x 20).
⁽³⁾ Determined with halogen tungsten lamp 3000 °K.
 Note: for a proper use see norms at pages 18, 19, 20, 21 and 22.

WIRING DIAGRAMS

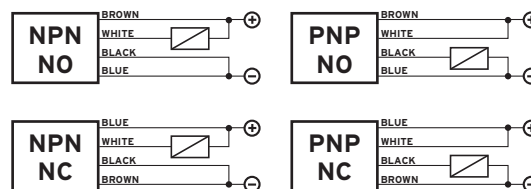

CONNECTION WITH CONNECTOR M12 (K)

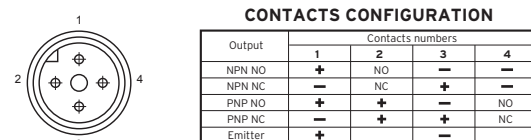

View of quadripole male connector

Note: Photoelectric sensor not suitable for use with 90° connectors.

SENSITIVITY ADJUSTMENT

- 1) SENSITIVITY INCREASE**
Screw the trimmer towards right towards position "+"
- 2) SENSITIVITY DECREASE**
Screw the trimmer towards left towards position "-"

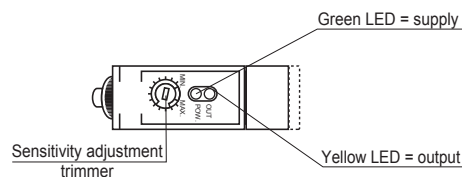

Note: the trimmer just needs one turn.

DIMENSIONS (mm)

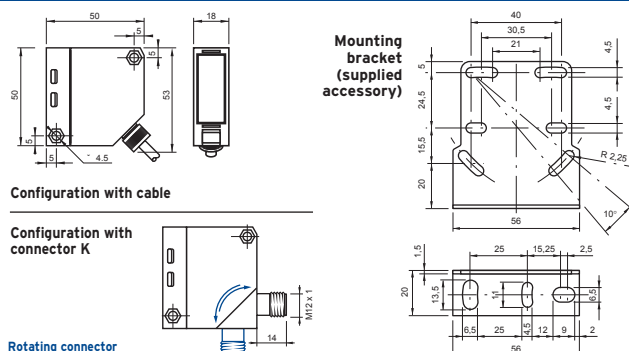

CHARACTERISTIC CURVES

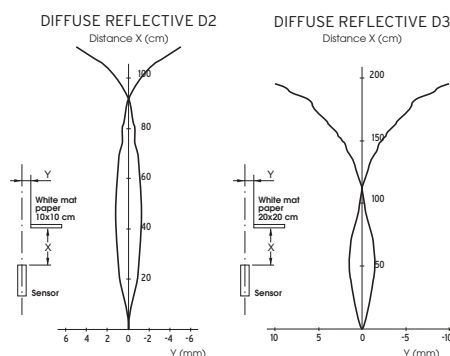

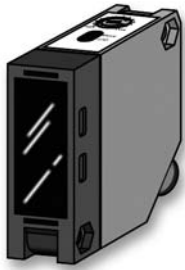

PHOTOELECTRIC SENSORS

DIFFUSE REFLECTIVE 14÷230 V AC/DC - RELAY OUTPUT

- Square housing
- Wide input voltage
- 3A relay SPDT
- Cable or M12 quick connect models
- Output and Supply indicators



FQ Series



IDENTIFICATION CODE

FQ **05** **D2** **K**

SERIES FQ

RELAY OUTPUT NORMAL OFF

Switching distance = 10 ÷ 40 cm

Switching distance = 25 ÷ 100 cm

Switching distance = 35 ÷ 180 cm

Switching distance = 40 ÷ 200 cm

D1

D2

D3

D4

CONNECTOR OUTPUT M12

SHIELDED	D1	D2	D3	D4
NOMINAL SWITCHING DISTANCE (Sn)	10...40cm	25...100cm ⁽¹⁾	35...180cm ⁽²⁾	40...200cm
TOLERANCE	+10/-10 %Sn			
HYSTERESIS	10%			
EMISSION	Infrared (875 nm)			
NOMINAL VOLTAGE	14 ÷ 230V AC - DC (-15 /+10%)			
MAINS FREQUENCY	50 ÷ 60 Hz			
OUTPUT	Relay (10 x 10 ⁶ ops. min.)			
MAX. OUTPUT CURRENT	3A 30 VAC - 1A 220 VAC (90W, 360 VA)			
ABSORPTION	2.5 VA			
YELLOW LED	Output indicator			
GREEN LED	Supply indicator			
SENSITIVITY ADJUSTMENT	Trimmer 1 turn			
SWITCHING FREQUENCY	10 Hz			
RESPONSE TIME	50 ms			
START UP DELAY	300 ms			
TEMPERATURE LIMITS	-10 ÷ +60 °C			
LIGHT IMMUNITY	> 10.000 Lux ⁽³⁾			
PROTECTION DEGREE	IP 65			
CABLE LENGTH	2 m			
CABLE SECTION	5 x 0.30 mm ²			
HOUSING MATERIAL	Housing: ABS - Lenses: methacrylate			
WEIGHT - cable output - (connector output)	- 180 g - (125 g)			

⁽¹⁾ Determined with a white mat paper (cm 10 x 10).

⁽²⁾ Determined with a white mat paper (cm 20 x 20).

⁽³⁾ Determined with halogen tungsten lamp 3000 °K.

Note: for a proper use see norms at pages 18, 19, 20, 21 and 22.

WIRING DIAGRAMS

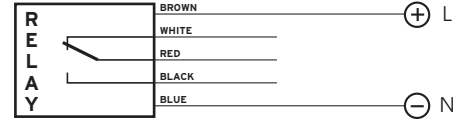

Note: in case of inductive loads it is necessary to connect one diode in antiparallel at the edges of the load.

CONNECTION WITH CONNECTOR M12 (K)

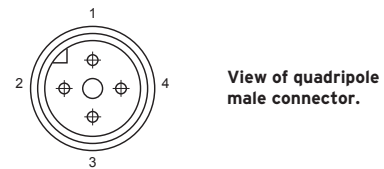

View of quadripole male connector.

CONTACTS CONFIGURATION

Output	Contacts numbers			
	1	2	3	4
Relay	L	COM	N	NO
Wire colors	brown	white	blue	black

Note: Photoelectric sensor not suitable for use with 90° connectors.

SENSITIVITY ADJUSTMENT

- 1) SENSITIVITY INCREASE**
Screw the trimmer towards right towards position "+"
- 2) SENSITIVITY DECREASE**
Screw the trimmer towards left towards position "-"

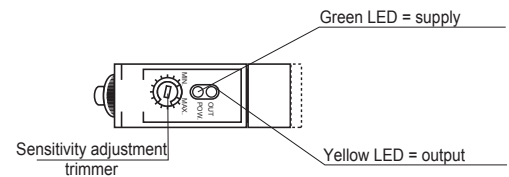

Note: the trimmer just needs one turn.

DIMENSIONS (mm)

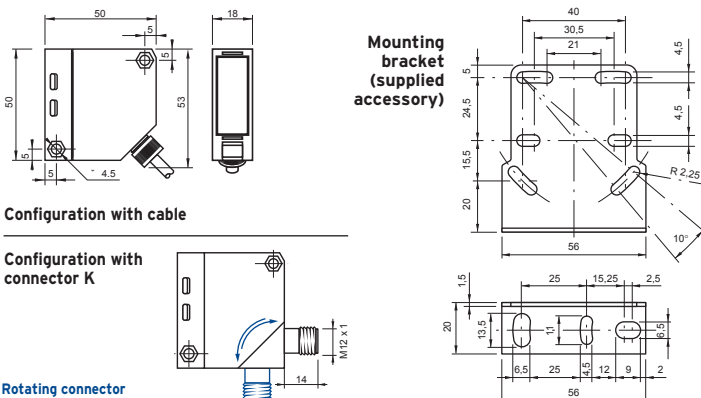

PHOTOELECTRIC

CHARACTERISTIC CURVES

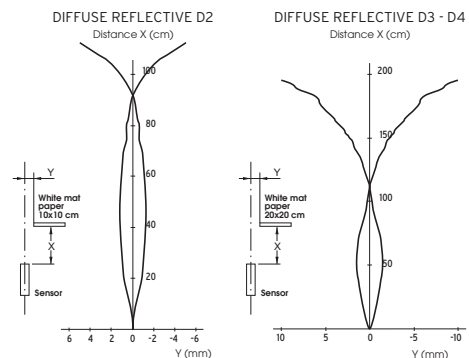



PHOTOELECTRIC SENSORS

DIFFUSE REFLECTIVE

12÷30 V DC - NPN OR PNP OUTPUT

- Laser square housing Class 1
- Compact size 50x50x15
- M12 quick connect models
- Sensitivity adjustment



FQL Series



IDENTIFICATION CODE

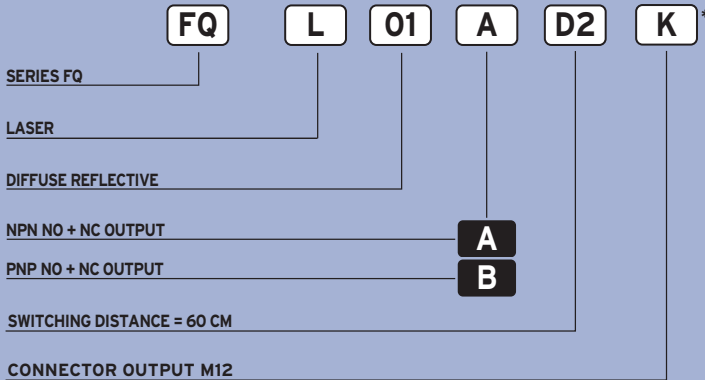

* only connector version available

AVAILABLE	DIFFUSE REFLECTIVE
NOMINAL SWITCHING DISTANCE (Sn)	60 cm ⁽¹⁾
HOUSING MATERIAL	ABS
OPERATING VOLTAGE	10÷30 VDC
RESIDUAL RIPPLE	< 2Vpp
ABSORPTION	< 35 mA
EMISSION	Red Laser 650 nm Class 1 EN60825-1
MAX. OUTPUT CURRENT	< 10 mA
VOLTAGE DROP	< 2 V
SWITCHING FREQUENCY	2 kHz
RESPONSE TIME	250 ms
SENSITIVITY ADJUSTMENT	Present
LED	Present
LIGHT IMMUNITY	> 5000 Lux ⁽²⁾
PROTECTION DEGREE	IP 67
TEMPERATURE LIMITS	-10/+50 °C
RESOLUTION	App. 10 mm
REVERSE POLARITY PROTECTION	Present
SHORT CIRCUIT PROTECTION	Present
OVERLOAD TRIP POINT	-
START UP DELAY	< 300 ms
CONNECTION	M12Connector
WEIGHT	43 g

⁽¹⁾ Determined with a white mat paper (cm 10 x 10).
⁽²⁾ Determined with halogen tungsten lamp 3000 °K.
 Note: for a proper use see norms at pages 18, 19, 20, 21 and 22.

WIRING DIAGRAMS

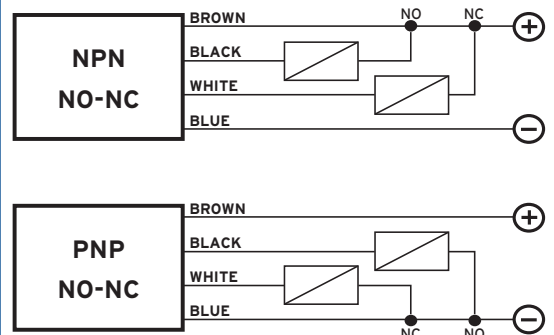

CONNECTION WITH CONNECTOR M12 (K)

View of quadripole male connector

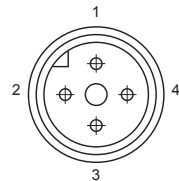

CONTACTS CONFIGURATION

Available	Contacts numbers			
	1	2	3	4
(NO + NC)	+	NC	-	NO

SENSITIVITY ADJUSTMENT

- 1) **SENSITIVITY INCREASE**
Screw the trimmer towards right towards position "+"
- 2) **SENSITIVITY DECREASE**
Screw the trimmer towards left towards position "-"

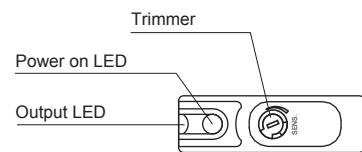

Note: the trimmer just needs one turn.

DIMENSIONS (mm)

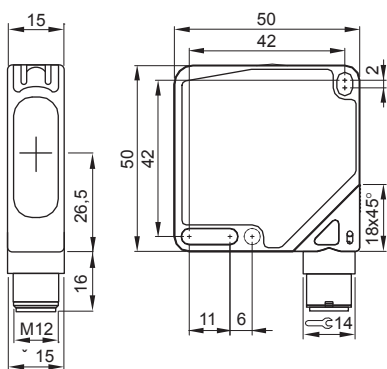

CHARACTERISTIC CURVES

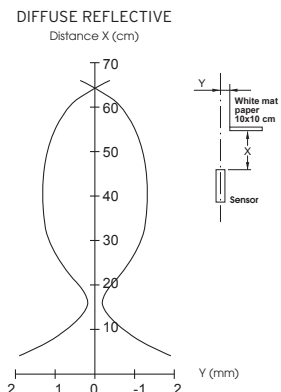

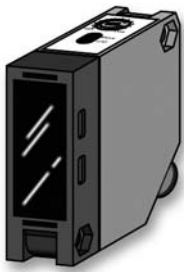

PHOTOELECTRIC SENSORS

BACKGROUND SUPPRESSION 12÷30 V DC - NPN/PNP OUTPUT

- Square housing
- Compact size, output and supply indicators
- Insensitive to colours
- Cable or M12 quick connect models
- Fast response time: 1 ms ON/OFF

FQ Series



IDENTIFICATION CODE

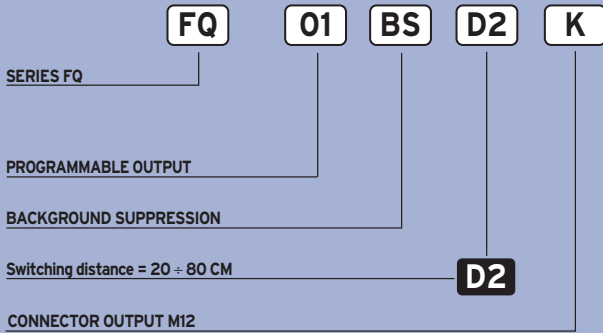

AVAILABLE	D2
NOMINAL SWITCHING DISTANCE (Sn)	20 ÷ 80 cm ⁽¹⁾
TOLERANCE	+10/-10 %Sn
HYSTERESIS	10%
EMISSION	Infrared (875 nm)
NOMINAL VOLTAGE	12 ÷ 30VDC (-15 /+10%)
RESIDUAL RIPPLE	10%
OUTPUT	NPN or PNP
CONTACT	NO+NC
MAX. OUTPUT CURRENT	200 mA
ABSORPTION AT 30 VDC	30 mA
VOLTAGE DROP (Sensor ON)	1.5 V (I = 100 mA)
YELLOW LED	Output indicator
GREEN LED	Stability indicator
SENSITIVITY ADJUSTMENT	Trimmer 1 turn
SWITCHING FREQUENCY	500 Hz
RESPONSE TIME	1 ms
START UP DELAY	100 ms
SHORT CIRCUIT PROTECTION	Present (self-resetting)
ELECTRIC PROTECTIONS	Against polarity reversal - inductive loads
TEMPERATURE LIMITS	-25 ÷ +55 °C
LIGHT IMMUNITY	> 10.000 Lux ⁽²⁾
PROTECTION DEGREE	IP 65
HOUSING MATERIAL	Housing: ABS - Lenses: methacrylate
WEIGHT (connector output)	120 g

⁽¹⁾ Determined with a white mat paper (cm 10 x 10).
⁽²⁾ Determined with halogen tungsten lamp 3000 °K.
 Note: for a proper use see norms at pages 18, 19, 20, 21 and 22.

WIRING DIAGRAMS

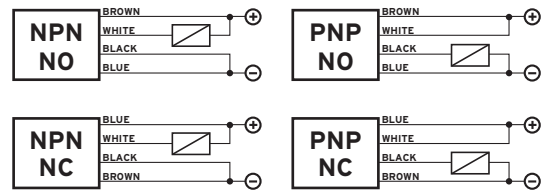

CONNECTION WITH CONNECTOR M12 (K)

View of quadripole male connector

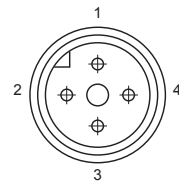

CONTACTS CONFIGURATION

Available	Contacts numbers			
	1	2	3	4
(NO + NC)	+	NC	-	NO

Note: Photoelectric sensor not suitable for use with 90° connectors.

SENSIBILITY ADJUSTMENT

- 1) SENSITIVITY INCREASE
Screw the trimmer towards right towards position "+"
- 2) SENSITIVITY DECREASE
Screw the trimmer towards left towards position "-"

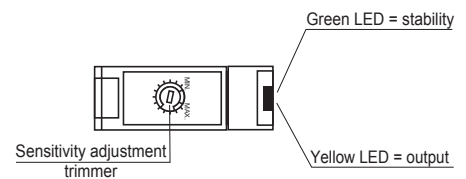

Note: the trimmer just needs one turn.

DIMENSIONS (mm)

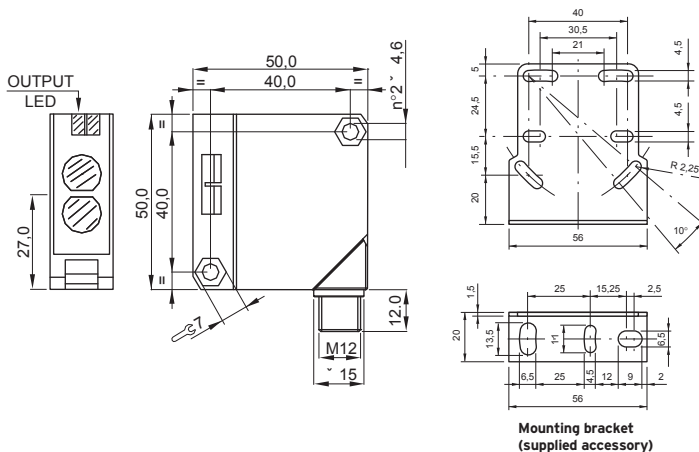

CHARACTERISTIC CURVES

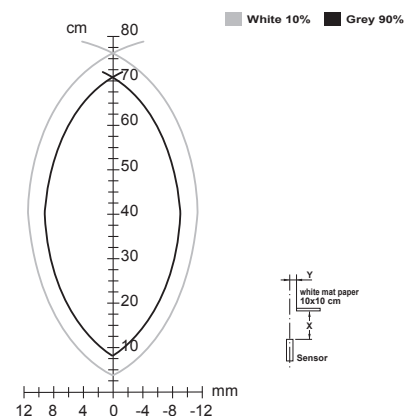

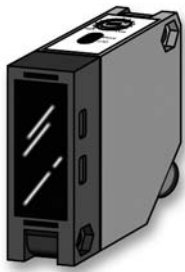

PHOTOELECTRIC SENSORS



RETRO REFLECTIVE 12÷30 V DC PROGRAMMABLE OUTPUT

- Square housing
- Compact size, output and stability indicators
- Cost effective
- Cable or M12 quick connect models
- Fast response time: 2.5 ms / 200 Hz
- Version for transparent

FQ Series



IDENTIFICATION CODE

FQ **02** **P** **T*** **K**

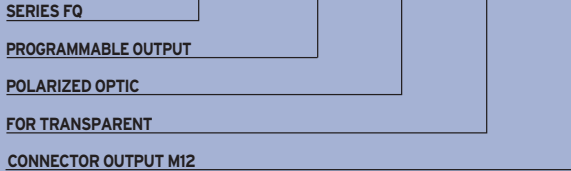

* Available only with "P" option.

AVAILABLE	POLARIZED	POLAR. FOR TRANSPARENT	STANDARD
NOMINAL SWITCHING DISTANCE (Sn)	6 m ⁽¹⁾	0,05 ÷ 2m ⁽¹⁾	13 m ⁽¹⁾
TOLERANCE	+10/-10 %Sn		
HYSTERESIS	10%		
EMISSION	Red (660 nm)	Infrared (875 nm)	
NOMINAL VOLTAGE	12 ÷ 30VDC (-15 /+10%)		
RESIDUAL RIPPLE	10%		
OUTPUT	NPN or PNP (programmable)		
CONTACT	NO or NC (programmable)		
MAX. OUTPUT CURRENT	200 mA		
ABSORPTION AT 30 VDC	40 mA		
VOLTAGE DROP (Sensor ON)	1.8 V (I = 100 mA)		
YELLOW LED	Output indicator		
GREEN LED	Supply indicator		
SENSITIVITY ADJUSTMENT	Trimmer 1 turn		
SWITCHING FREQUENCY	200 Hz		
RESPONSE TIME	2.5 ms		
START UP DELAY	100 ms		
SHORT CIRCUIT PROTECTION	Present (self-resetting)		
ELECTRIC PROTECTIONS	Against polarity reversal - inductive loads		
TEMPERATURE LIMITS	-10 ÷ +60 °C		
LIGHT IMMUNITY	> 10.000 Lux ⁽²⁾		
PROTECTION DEGREE	IP 65		
CABLE LENGTH	2 m		
CABLE SECTION	4 x 0.25 mm ²		
HOUSING MATERIAL	Housing: ABS - Lenses: methacrylate		
WEIGHT - cable output - (connector output)	- 160 g - (120 g)		

⁽¹⁾ Determined with CTO4S reflector.

⁽²⁾ Determined with halogen tungsten lamp 3000 °K.

Note: for a proper use see norms at pages 18, 19, 20, 21 and 22.

WIRING DIAGRAMS

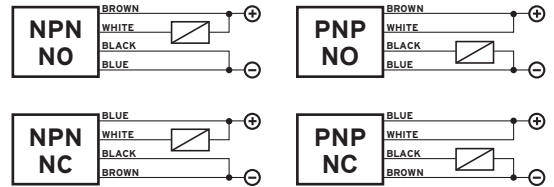

CONNECTION WITH CONNECTOR M12 (K)

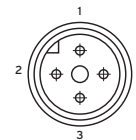

CONTACTS CONFIGURATION

Output	Contacts numbers			
	1	2	3	4
NPN NO	+	NO	-	-
NPN NC	-	NC	+	-
PNP NO	+	+	-	NO
PNP NC	-	+	+	NC
Emitter	+	-	-	-

View of quadripole male connector.

Note: Photoelectric sensor not suitable for use with 90° connectors.

SENSITIVITY ADJUSTMENT

- 1) SENSITIVITY INCREASE**
Screw the trimmer towards right towards position "+"
- 2) SENSITIVITY DECREASE**
Screw the trimmer towards left towards position "-"

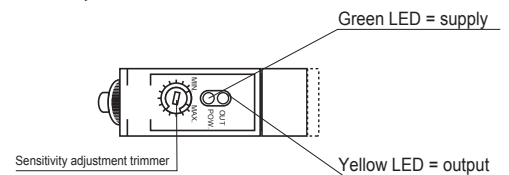

Note: the trimmer just needs one turn.

DIMENSIONS (mm)

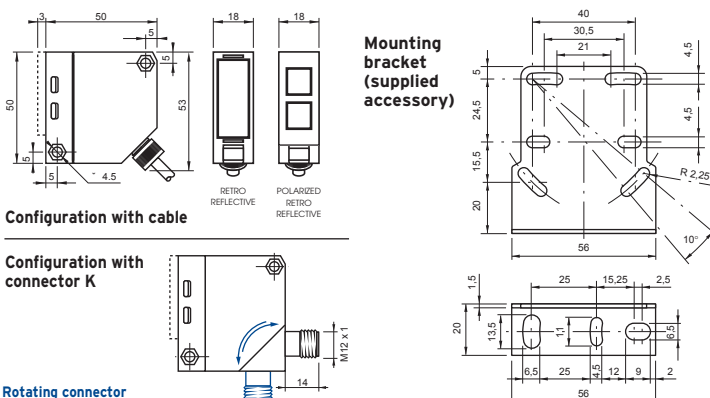

Mounting bracket (supplied accessory)

Configuration with cable

Configuration with connector K

Rotating connector

CHARACTERISTIC CURVES

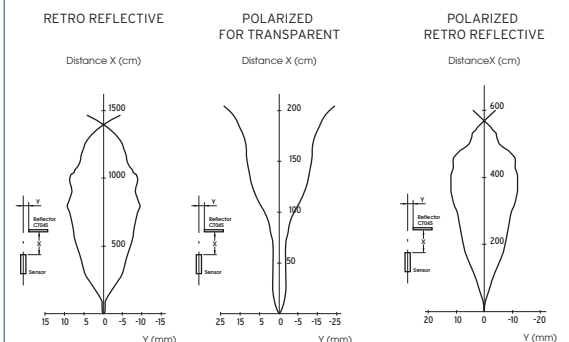

PHOTOELECTRIC SENSORS



FQ Series

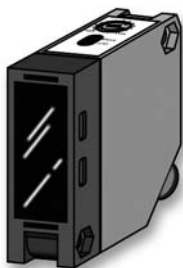

RETRO REFLECTIVE

14÷230 V AC/DC PROGRAMMABLE OUTPUT

- Square housing
- Wide input voltage
- 3A relay SPDT
- Cable or M12 quick connect models
- Output and Supply indicators

IDENTIFICATION CODE

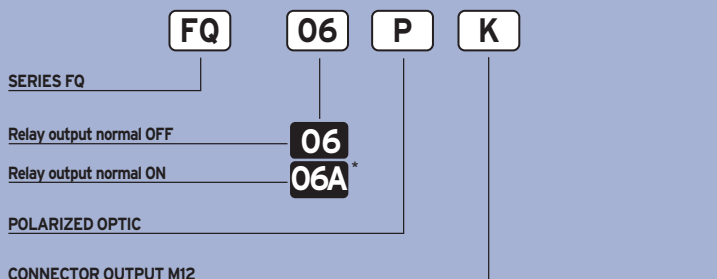

* This version is made with NORMALLY ACTIVATED RELAY when the photocell is aligned with the reflector.

AVAILABLE	POLARIZED	STANDARD
NOMINAL SWITCHING DISTANCE (Sn)	6 m ⁽¹⁾	13 m ⁽¹⁾
TOLERANCE	+10/-10 %Sn	
HYSTERESIS	10%	
EMISSION	Red (660 nm)	Infrared (875 nm)
NOMINAL VOLTAGE	14 ÷ 230V AC - DC (-15 /+10%)	
MAINS FREQUENCY	50 ÷ 60 Hz	
OUTPUT	Relay (10 x 10 ⁶ ops. min.)	
MAX. OUTPUT CURRENT	3A 30 VAC - 1A 220 VAC (90W, 360 VA)	
ABSORPTION	2.5 VA	
YELLOW LED	Output indicator	
GREEN LED	Supply indicator	
SENSITIVITY ADJUSTMENT	Trimmer 1 turn	
SWITCHING FREQUENCY	10 Hz	
RESPONSE TIME	50 ms	
START UP DELAY	300 ms	
TEMPERATURE LIMITS	-10 ÷ +60 °C	
LIGHT IMMUNITY	> 10.000 Lux ⁽²⁾	
PROTECTION DEGREE	IP 65	
CABLE LENGTH	2 m	
CABLE SECTION	5 x 0.30 mm ²	
HOUSING MATERIAL	Housing: ABS - Lenses: methacrylate	
WEIGHT - cable output - (connector output)	- 180 g - (125 g)	

⁽¹⁾ Determined with CTO4S reflector.
⁽²⁾ Determined with halogen tungsten lamp 3000 °K.
 Note: for a proper use see norms at pages 18, 19, 20, 21 and 22.

WIRING DIAGRAMS

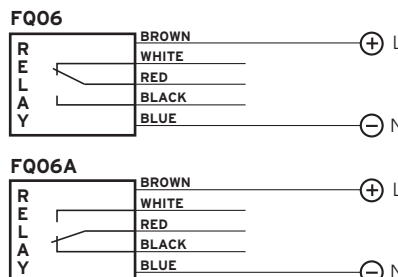

Note: in case of inductive loads it is necessary to connect one diode in antiparallel at the edges of the load.

CONNECTION WITH CONNECTOR M12 (K)

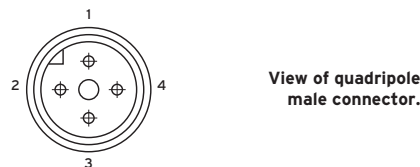

CONTACTS CONFIGURATION

Output	Contacts numbers			
	1	2	3	4
Relay	L	COM	N	NO
Wire colors	brown	white	blue	black

Note: Photoelectric sensor not suitable for use with 90° connectors.

SENSITIVITY ADJUSTMENT

- 1) SENSITIVITY INCREASE**
Screw the trimmer towards right towards position "+"
- 2) SENSITIVITY DECREASE**
Screw the trimmer towards left towards position "-"

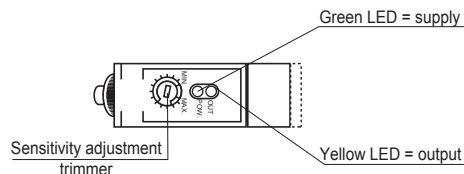

Note: the trimmer just needs one turn.

DIMENSIONS (mm)

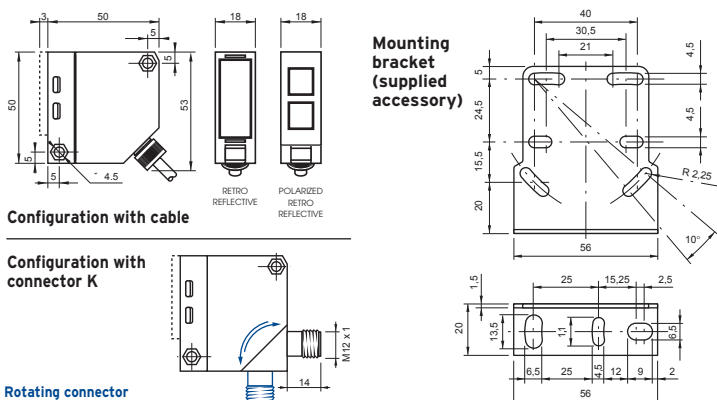

CHARACTERISTIC CURVES

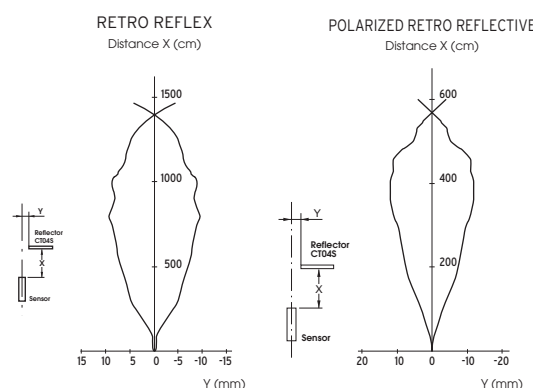



PHOTOELECTRIC SENSORS



RETRO REFLECTIVE

12÷30 V DC - NPN OR PNP OUTPUT

- Laser square housing Class 1
- Compact size 50x50x15
- M12 quick connect models
- Sensitivity adjustment

FQL Series



IDENTIFICATION CODE

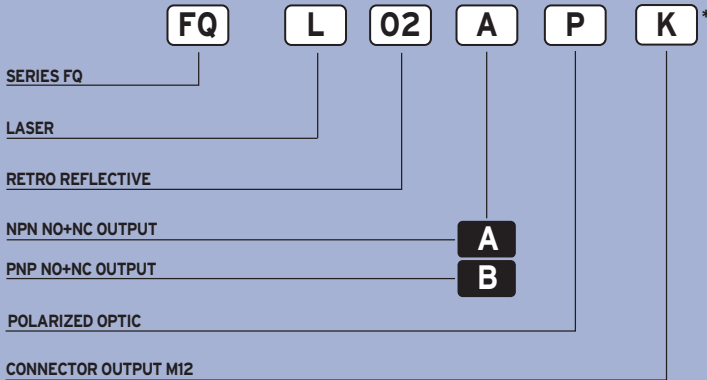

* Only connector version available

AVAILABLE	POLARIZED RETRO REFLECTIVE
NOMINAL SWITCHING DISTANCE (Sn)	20 m ⁽¹⁾
HOUSING MATERIAL	ABS
OPERATING VOLTAGE	10÷30 VDC
RESIDUAL RIPPLE	< 2Vpp
ABSORPTION	< 35 mA
EMISSION	Red Laser 650 nm Class 1 EN60825-1
MAX. OUTPUT CURRENT	< 10 mA
VOLTAGE DROP	< 2 V
SWITCHING FREQUENCY	2 kHz
RESPONSE TIME	250 ms
SENSITIVITY ADJUSTMENT	Present
LED	Present
LIGHT IMMUNITY	> 5000 Lux ⁽²⁾
PROTECTION DEGREE	IP 67
TEMPERATURE LIMITS	-10/+50 °C
RESOLUTION	App. 10 mm
REVERSE POLARITY PROTECTION	Present
SHORT CIRCUIT PROTECTION	Present
START UP DELAY	< 300 ms
CONNECTION	M12 Connector
WEIGHT	43 g

⁽¹⁾ Determined with CT04S reflector.

⁽²⁾ Determined with halogen tungsten lamp 3000 °K.

Note: for a proper use see norms at pages 18, 19, 20, 21 and 22.

WIRING DIAGRAMS

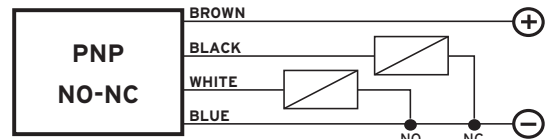
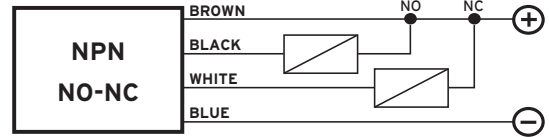

CONNECTION WITH CONNECTOR M12 (K)

View of quadripole male connector

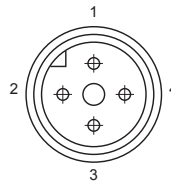

CONTACTS CONFIGURATION

Available	Contacts numbers			
	1	2	3	4
(NO + NC)	+	NC	-	NO

SENSITIVITY ADJUSTMENT

- 1) SENSITIVITY INCREASE**
Screw the trimmer towards right towards position "+"
- 2) SENSITIVITY DECREASE**
Screw the trimmer towards left towards position "-"

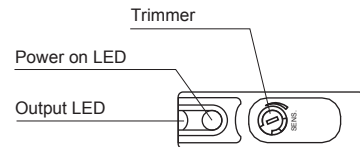

Note: the trimmer just needs one turn.

DIMENSIONS (mm)

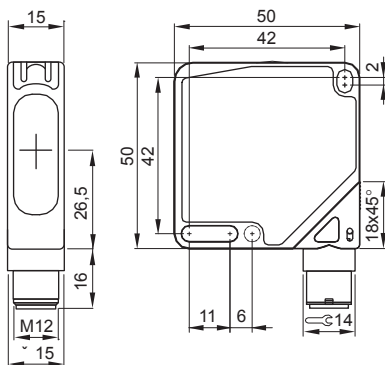

CHARACTERISTIC CURVES

POLARIZED RETRO REFLECTIVE
Distance X (m)

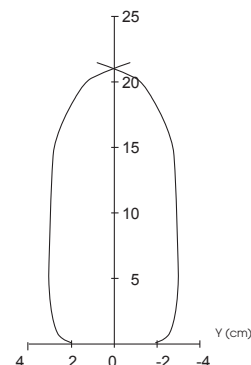

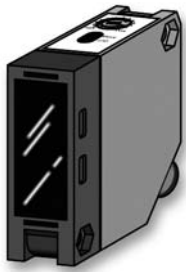

PHOTOELECTRIC SENSORS



THRU BEAM

12÷30 V DC - PROGRAMMABLE OUTPUT

- Square housing
- Compact size, output and stability indicators
- Cost effective
- Cable or M12 quick connect models
- Fast response time: 2.5 ms

FQ Series



IDENTIFICATION CODE

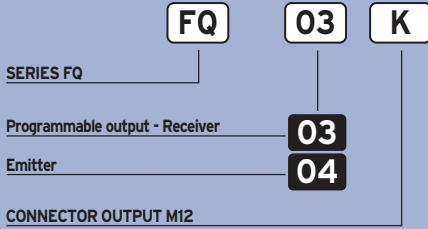

AVAILABLE	RECEIVER	EMITTER
NOMINAL SWITCHING DISTANCE (Sn)	20 m	
TOLERANCE	+10/-10 %Sn	
HYSTERESIS	10%	
EMISSION	Infrared (875 nm)	
NOMINAL VOLTAGE	12 ÷ 30VDC (-15 /+10%)	
RESIDUAL RIPPLE	10%	
OUTPUT	NPN or PNP (programmable)	-
CONTACT	NO or NC (programmable)	-
MAX. OUTPUT CURRENT	200 mA	-
ABSORPTION AT 30 VDC	25 mA	
VOLTAGE DROP (Sensor ON)	1.8 V (I = 100 mA)	-
YELLOW LED	Output indicator	-
GREEN LED	Stability indicator	Supply indicator
SENSITIVITY ADJUSTMENT	Trimmer 1 turn	-
SWITCHING FREQUENCY	200 Hz	
RESPONSE TIME	2.5 ms	
START UP DELAY	100 ms	
SHORT CIRCUIT PROTECTION	Present (self-resetting)	
ELECTRIC PROTECTIONS	Against polarity reversal - inductive loads	
TEMPERATURE LIMITS	-10 ÷ +60 °C	
LIGHT IMMUNITY	> 10.000 Lux ⁽¹⁾	
PROTECTION DEGREE	IP 65	
CABLE LENGTH	2 m	
CABLE SECTION	4 x 0.25 mm ²	2 x 0.25 mm ²
HOUSING MATERIAL	Housing: ABS - Lenses: methacrylate	
WEIGHT - cable output - (connector output)	- 160 g - (120 g)	

⁽¹⁾ Determined with halogen tungsten lamp 3000 °K.
 Note: for a proper use see norms at pages 18, 19, 20, 21 and 22.

WIRING DIAGRAMS

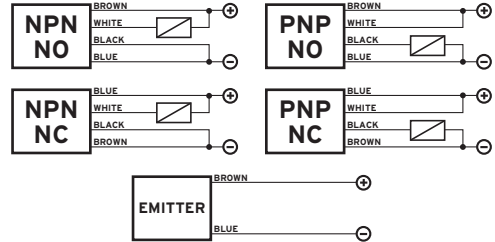

CONNECTION WITH CONNECTOR M12 (K)

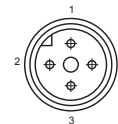

CONTACTS CONFIGURATION

Output	Contacts numbers			
	1	2	3	4
NPN NO	+	NO	-	-
NPN NC	-	NC	+	-
PNP NO	+	+	-	NO
PNP NC	-	+	+	NC
Emitter	+	-	-	-

View of quadrupole male connector.

Note: Photoelectric sensor not suitable for use with 90° connectors.

SENSITIVITY ADJUSTMENT

- 1) SENSITIVITY INCREASE**
Screw the trimmer towards right towards position "+"
- 2) SENSITIVITY DECREASE**
Screw the trimmer towards left towards position "-"

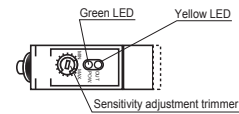

Note: the trimmer just needs one turn.

STABILITY SIGNAL LED

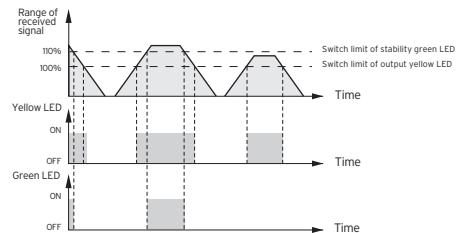

The stability signal LED shows the range of received signal and helps the photoelectric sensor to line up. A photoelectric sensor works in "stability" condition when the received light signal range is 10% ahead the switching limit of output.

DIMENSIONS (mm)

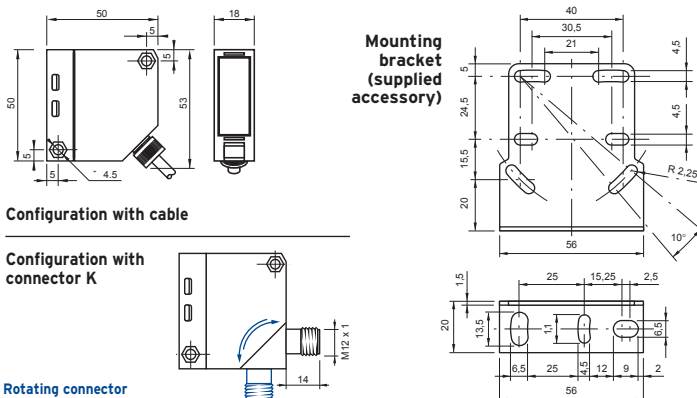

CHARACTERISTIC CURVES

EMITTER RECEIVER THRU BEAM

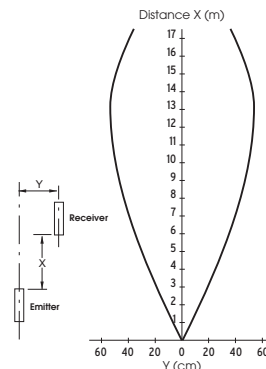

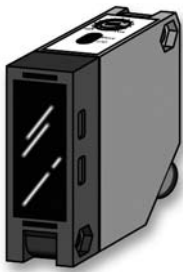

PHOTOELECTRIC SENSORS



THRU BEAM

14 ÷ 230 V AC/DC - RELAY OUTPUT

- Square housing
- Wide input voltage
- 3A relay SPDT
- Cable or M12 quick connect models
- Output and Stability indicators

FQ Series



IDENTIFICATION CODE

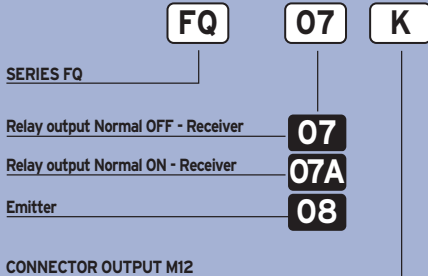

AVAILABLE	RECEIVER	EMITTER
NOMINAL SWITCHING DISTANCE (Sn)	20 m	
TOLERANCE	+10/-10 %Sn	
HYSTERESIS	10%	
EMISSION	-	Infrared (875 nm)
NOMINAL VOLTAGE	14 ÷ 230V AC - DC (-15 /+10%)	
MAINS FREQUENCY	50 ÷ 60 Hz	
OUTPUT	Relay (10 x 10 ⁶ ops. min.)	-
MAX. OUTPUT CURRENT	3A 30 VAC - 1A 220 VAC (90W, 360 VA)	-
ABSORPTION	2.5 VA	
YELLOW LED	Output indicator	-
GREEN LED	Supply indicator	
SENSITIVITY ADJUSTMENT	Trimmer 1 turn	-
SWITCHING FREQUENCY	10 Hz	
RESPONSE TIME	50 ms	
START UP DELAY	300 ms	
TEMPERATURE LIMITS	-10 ÷ +60 °C	
LIGHT IMMUNITY	> 10.000 Lux ⁽¹⁾	
PROTECTION DEGREE	IP 65	
CABLE LENGTH	2 m	
CABLE SECTION	5 x 0.30 mm ²	2 x 0.25 mm ²
HOUSING MATERIAL	Housing: ABS - Lenses: methacrylate	
WEIGHT - cable output - (connector output)	- 180 g - (125 g)	

⁽¹⁾ Determined with halogen tungsten lamp 3000 °K.
 Note: for a proper use see norms at pages 18, 19, 20, 21 and 22.

WIRING DIAGRAMS

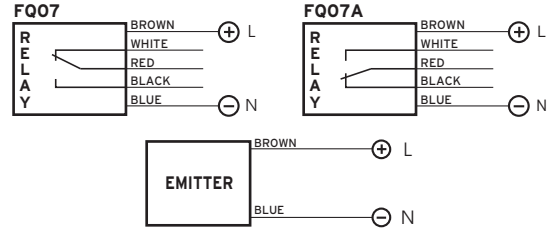

Note: in case of inductive loads it is necessary to connect one diode in antiparallel at the edges of the load.

CONNECTION WITH CONNECTOR M12 (K)

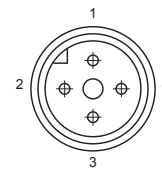

View of quadrupole male connector.

CONTACTS CONFIGURATION

Output	Contacts numbers			
	1	2	3	4
Relay L (+)	COM	N	NO	-
Emitter L (+)	-	N (-)	-	-
Wire colors	brown	white	blue	black

Note: Photoelectric sensor not suitable for use with 90° connectors.

SENSITIVITY ADJUSTMENT

- 1) SENSITIVITY INCREASE**
Screw the trimmer towards right towards position "+"
- 2) SENSITIVITY DECREASE**
Screw the trimmer towards left towards position "-"

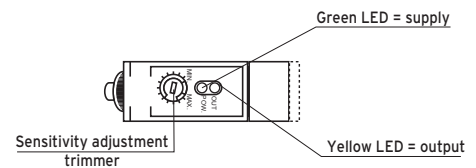

Note: the trimmer just needs one turn.

DIMENSIONS (mm)

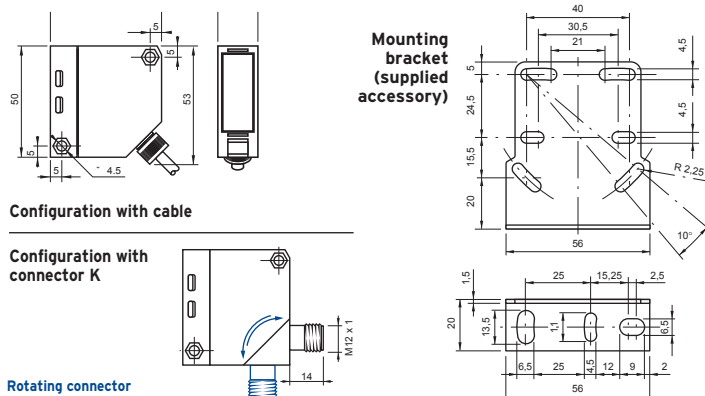

Configuration with cable

Configuration with connector K

Rotating connector

CHARACTERISTIC CURVES

EMITTER RECEIVER THRU BEAM
 Distance X (m)

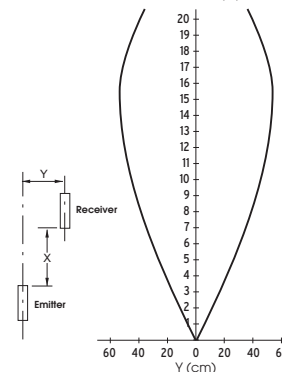



PHOTOELECTRIC SENSORS



THRU BEAM

10÷30 V DC - NPN OR PNP OUTPUT

- Laser square housing Class 1
- Compact size 50x50x15
- M12 quick connect models
- Sensitivity adjustment

FQL Series



IDENTIFICATION CODE

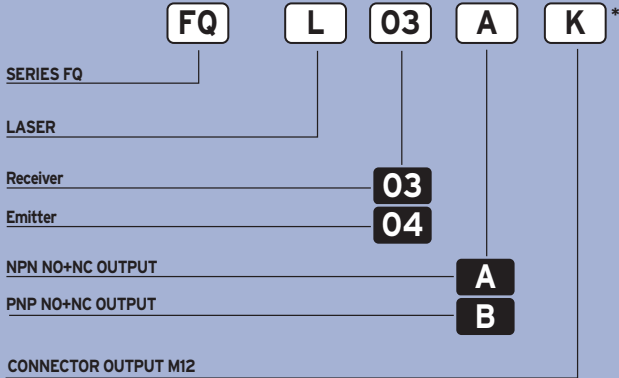

* Only connector version available.

AVAILABLE	THRU BEAM
NOMINAL SWITCHING DISTANCE (Sn)	60 m
HOUSING MATERIAL	ABS
OPERATING VOLTAGE	10 ÷ 30 VDC
RESIDUAL RIPPLE	< 2Vpp
ABSORPTION	< 35 mA
EMISSION	Red Laser 650 nm Class 1 EN60825-1
MAX. OUTPUT CURRENT	< 10 mA
VOLTAGE DROP	< 2 V
SWITCHING FREQUENCY	1.5 kHz
RESPONSE TIME	333 ms
SENSITIVITY ADJUSTMENT	Present
LED	Present
LIGHT IMMUNITY	> 5.000 Lux ⁽¹⁾
PROTECTION DEGREE	IP 67
TEMPERATURE LIMITS	-10/+50 °C
RESOLUTION	App. 10 mm
REVERSE POLARITY PROTECTION	Present
SHORT CIRCUIT PROTECTION	Present
START UP DELAY	< 300 ms
CONNECTION	M12Connector
WEIGHT	43 g

⁽¹⁾ Determined with halogen tungsten lamp 3000 °K.
Note: for a proper use see norms at pages 18, 19, 20, 21 and 22.

WIRING DIAGRAMS

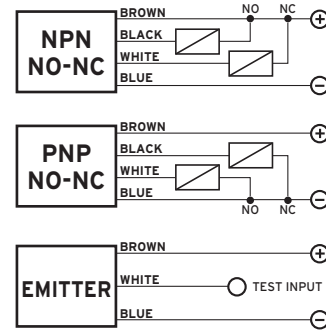

CONNECTION WITH CONNECTOR M12 (K)

View of quadripole male connector

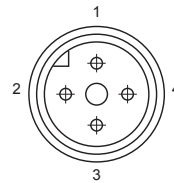

CONTACTS CONFIGURATION

Available	Contacts numbers			
	1	2	3	4
(NO + NC)	+	NC	-	NO
EMITTER	+	T.I.	-	

SENSITIVITY ADJUSTMENT

- 1) SENSITIVITY INCREASE**
Screw the trimmer towards right towards position "+"
- 2) SENSITIVITY DECREASE**
Screw the trimmer towards left towards position "-"

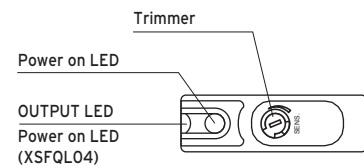

Note: the trimmer just needs one turn.

DIMENSIONS (mm)

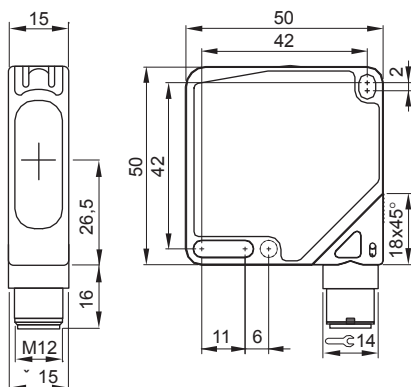

CHARACTERISTIC CURVES

EMITTER RECEIVER THRU BEAM

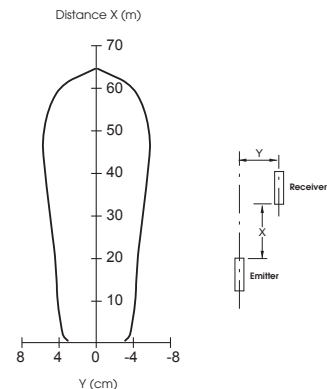

PHOTOELECTRIC



PHOTOELECTRIC SENSORS



DIFFUSE REFLECTIVE 12÷30 V DC WITH TIMER PROGRAMMABLE OUTPUT

- Rectangular housing
- Multi-function timer
- ON/OFF delay
- One shot-four functions
- NPN or PNP programmable output
- Conduit wiring terminal block

FW Series



IDENTIFICATION CODE

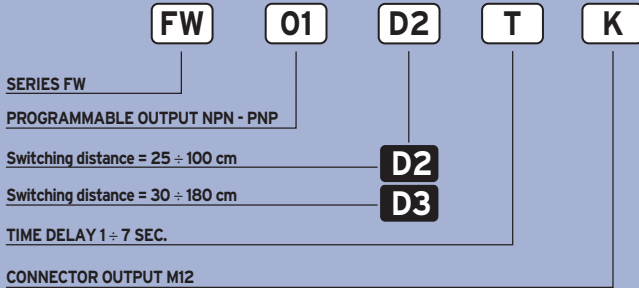

AVAILABLE	D2	D3
NOMINAL SWITCHING DISTANCE (Sn)	25 ÷ 100 cm ⁽¹⁾	30 ÷ 180 cm ⁽²⁾
TOLERANCE	+10/-10 %Sn	
HYSTERESIS	10%	
EMISSION	Infrared (875 nm)	
NOMINAL VOLTAGE	12 ÷ 30VDC (-15 /+10%)	
RESIDUAL RIPPLE	≤ 10%	
OUTPUT	NPN or PNP (programmable)	
MAX OUTPUT CURRENT	200 mA	
ABSORPTION	≤ 40 mA	
VOLTAGE DECREASE	≤ 2.5 VDC	
YELLOW LED	Light on indicator	
GREEN LED	Supply indicator	
SENSITIVITY ADJUSTEMENT	Timer 1 turn	
TIME REGULATION	0.1 ÷ 7 s ± 2 s (only models with timer)	
SWITCHING FREQUENCY	200 Hz	
RESPONSE TIME	2.5 ms	
START UP DELAY	≤ 300 ms	
PROTECTION AGAINST SHORT-CIRCUIT	Present (self-resetting)	
TEMPERATURE LIMITS	-10° ÷ +60°C	
LIGHT IMMUNITY	>10.000 Lux ⁽³⁾	
PROTECTION DEGREE	IP 67	
CONNECTIONS	Screw or M12 conn.	
CABLE GUIDE	PG 13.5	
HOUSING MATERIAL	Housing: ABS - Lenses: methacrylate	
WEIGHT (Approximately)	110 g	

⁽¹⁾ Determined with a white mat paper (cm 10 x 10).
⁽²⁾ Determined with a white mat paper (cm 20 x 20).
⁽³⁾ Determined with halogen tungsten lamp 3000 °K.
 Note: for a proper use see norms at pages 18, 19, 20, 21 and 22.

DIMENSIONS (mm)

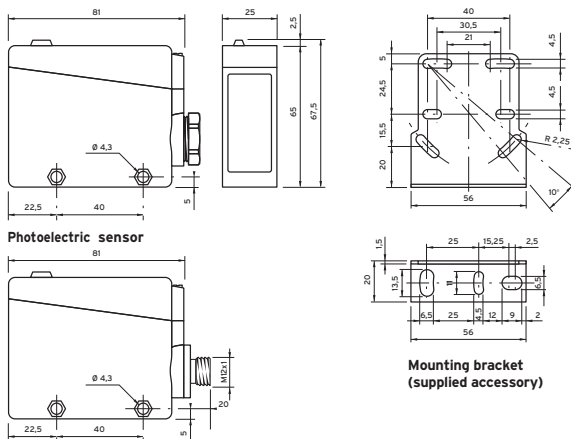

WIRING DIAGRAMS

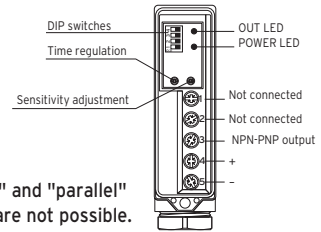

Note: "series" and "parallel" connections are not possible.

CONNECTION WITH CONNECTOR M12 (K)

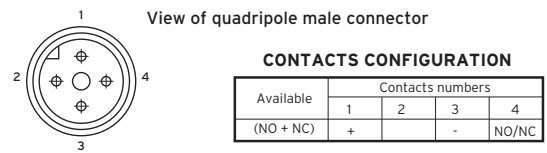

Note: Photoelectric sensor not suitable for use with 90° connectors.

TIMING DIAGRAMS

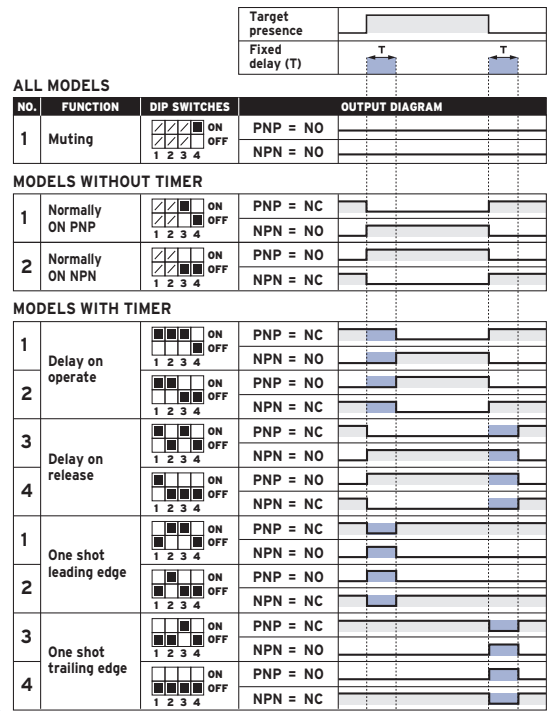

CHARACTERISTIC CURVES

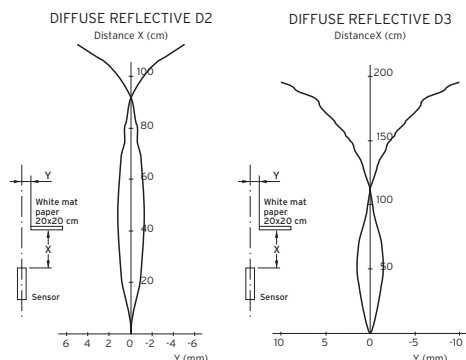

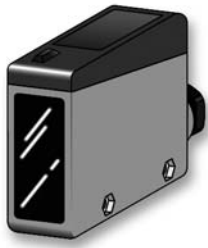

PHOTOELECTRIC SENSORS



DIFFUSE REFLECTIVE

14÷230 V AC/DC WITH TIMER RELAY OUTPUT

- Wide input voltage
- Rectangular compact size
- Multi-function timer
- ON/OFF delay
- One shot-four functions
- 3A relay SPDT
- Conduit wiring terminal block

FW Series



IDENTIFICATION CODE

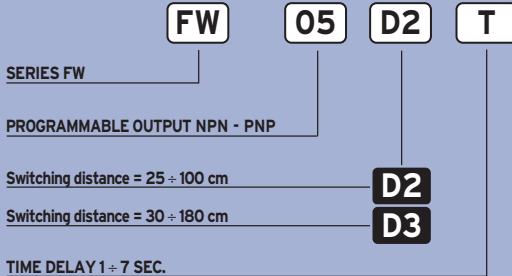

AVAILABLE	D2	D3
NOMINAL SWITCHING DISTANCE (Sn)	25...100 cm ⁽¹⁾	30...180 cm ⁽²⁾
TOLERANCE	+10/-10 %Sn	
HYSTERESIS	10%	
EMISSION	Infrared (875 nm)	
NOMINAL VOLTAGE	14-230VAC / DC (-15 /+10%)	
NET FREQUENCY	45 ÷ 60 Hz	
OUTPUT	Relay (40 x 10 ⁶ mec. op. -5 x 10 ⁶ elect. op.)	
MAX OUTPUT CURRENT	3A 250VAC - 3A 30VDC	
ABSORPTION	2W (2.5 VA)	
YELLOW LED	Light on indicator	
GREEN LED	Supply indicator	
SENSITIVITY ADJUSTMENT	Present	
TIME REGULATION	0.1 ÷ 7 s ± 2 s (only models with timer)	
SWITCHING FREQUENCY	10 Hz	
RESPONSE TIME	100 ms	
START UP DELAY	≤ 300 ms	
TEMPERATURE LIMITS	-10 ÷ +60 °C	
LIGHT IMMUNITY	> 10.000 Lux ⁽³⁾	
PROTECTION DEGREE	IP 67	
CONNECTIONS	Screw	
CABLE GUIDE	PG 13.5	
HOUSING MATERIAL	Housing: ABS - Lenses: methacrylate	
WEIGHT (Approximately)	110 g	

⁽¹⁾ Determined with a white mat paper (cm 10 x 10).
⁽²⁾ Determined with a white mat paper (cm 20 x 20).
⁽³⁾ Determined with halogen tungsten lamp 3000 °K.
 Note: for a proper use see norms at pages 18, 19, 20, 21 and 22.

WIRING DIAGRAMS

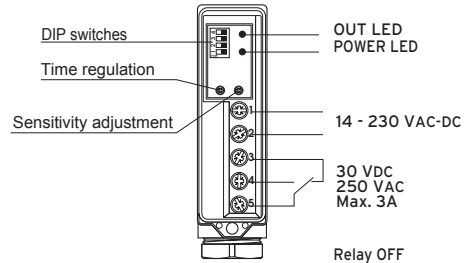

TIMING DIAGRAMS

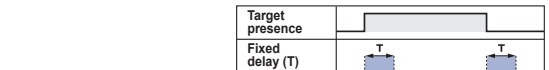

ALL MODELS

NO	FUNCTION	DIP SWITCHES	OUTPUT DIAGRAM
1	Muting	<input checked="" type="checkbox"/> ON <input type="checkbox"/> OFF 1 2 3 4	Not activated relay

MODELS WITHOUT TIMER

1	Normally ON	<input checked="" type="checkbox"/> ON <input type="checkbox"/> OFF 1 2 3 4	Normally activated relay
2	Normally OFF	<input type="checkbox"/> ON <input checked="" type="checkbox"/> OFF 1 2 3 4	Normally not activated relay

MODELS WITH TIMER

1	Delay on operate	<input checked="" type="checkbox"/> ON <input type="checkbox"/> OFF 1 2 3 4	Normally activated relay
2		<input type="checkbox"/> ON <input checked="" type="checkbox"/> OFF 1 2 3 4	Normally not activated relay
3	Delay on release	<input checked="" type="checkbox"/> ON <input type="checkbox"/> OFF 1 2 3 4	Normally activated relay
4		<input type="checkbox"/> ON <input checked="" type="checkbox"/> OFF 1 2 3 4	Normally not activated relay
1	One shot leading edge	<input checked="" type="checkbox"/> ON <input type="checkbox"/> OFF 1 2 3 4	Normally activated relay
2		<input type="checkbox"/> ON <input checked="" type="checkbox"/> OFF 1 2 3 4	Normally not activated relay
3	One shot trailing edge	<input checked="" type="checkbox"/> ON <input type="checkbox"/> OFF 1 2 3 4	Normally activated relay
4		<input type="checkbox"/> ON <input checked="" type="checkbox"/> OFF 1 2 3 4	Normally not activated relay

DIMENSIONS (mm)

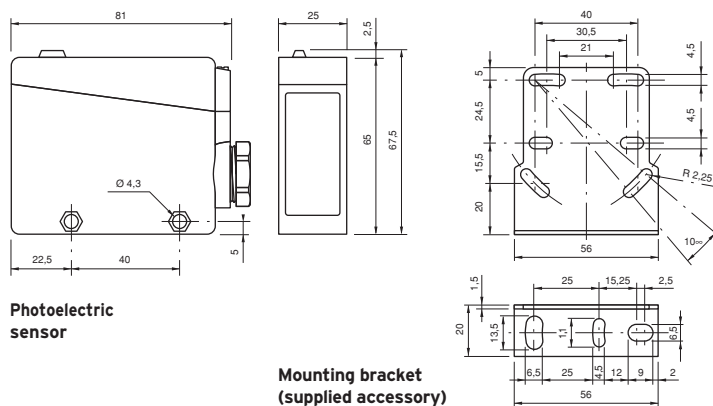

CHARACTERISTIC CURVES

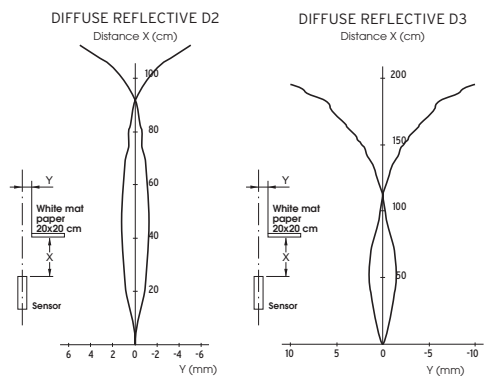

PHOTOELECTRIC



PHOTOELECTRIC SENSORS

BACKGROUND AND FOREGROUND SUPPRESSION 12÷30 V DC - PROGRAMMABLE OUTPUT



- Rectangular housing
- Switching distance: 300 cm
- Detecting black targets on white background
- Insensitive to colours
- Foreground suppression
- Conduit wiring terminal block

FW Series



IDENTIFICATION CODE

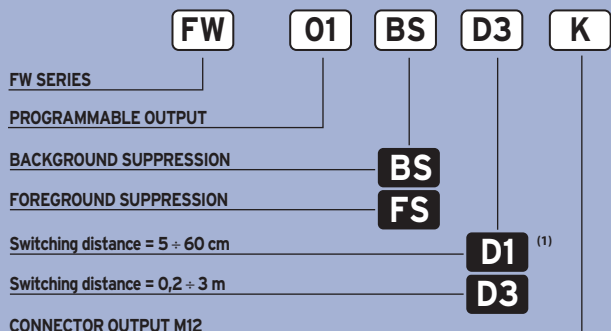

⁽¹⁾ Available only with option FS - not available with option BS

AVAILABLE	D1	D3
NOMINAL SWITCHING DISTANCE (Sn)	60 cm ⁽¹⁾	2 m ⁽¹⁾ (On White Target 3 m ⁽¹⁾)
TOLERANCE	+10/-10 %Sn	
HYSTERESIS	< 5%	
EMISSION	880 nm	
NOMINAL VOLTAGE	12 ÷ 30VDC (-15 /+10%)	
NET FREQUENCY	10%	
OUTPUT	NPN o PNP (programmable)	
CONTACT	NO o NC (programmable)	
MAX OUTPUT CURRENT	200 mA	
ABSORPTION	25 ÷ 40 mA	
VOLTAGE DROP	1.8 VDC	
YELLOW LED	Output indicator	
SWITCHING FREQUENCY	500 Hz	
RESPONSE TIME	1 ms	
SHORT CIRCUIT PROTECTION	Present (self-resetting)	
ELECTRICAL PROTECTION	Against polarity reversal - inductive loads	
TEMPERATURE LIMITS	-10 +60 °C	
LIGHT IMMUNITY	> 10.000 Lux ⁽²⁾	
PROTECTION DEGREE	IP 66	
CONNECTIONS	Screw or M12 conn.	
CABLE GUIDE	PG 13.5	
HOUSING MATERIAL	Housing: ABS - Lenses: methacrylate	
WEIGHT (Approximately)	110 g	

⁽¹⁾ Determined with a white mat paper (cm 20 x 20).

⁽²⁾ Determined with halogen tungsten lamp 3000 °K.

Note: for a proper use see norms at pages 18, 19, 20, 21 and 22.

DIMENSIONS (mm)

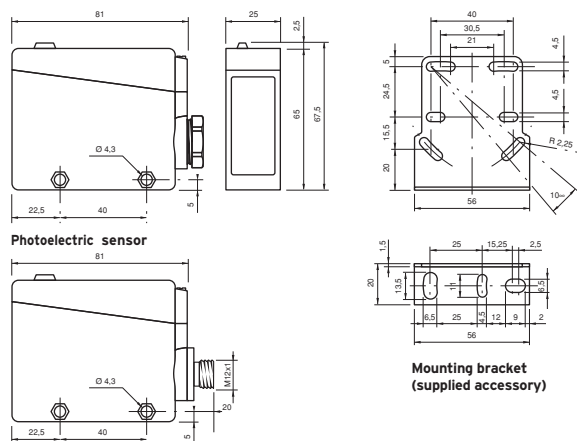

WIRING DIAGRAMS

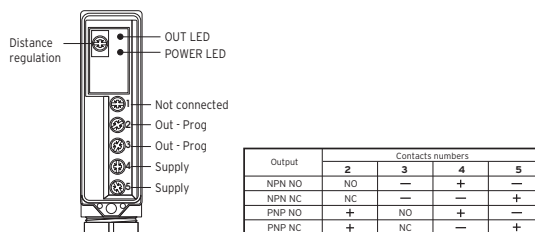

CONNECTION WITH CONNECTOR M12 (K)

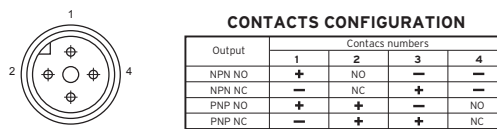

View of quadripole male connector.

Note: Photoelectric sensor not suitable for use with 90° connectors.

CHARACTERISTIC CURVES

Emission curve FW01BSD3

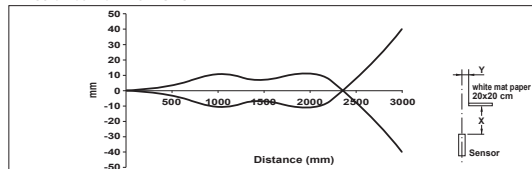

Emission curve FW01FSD1

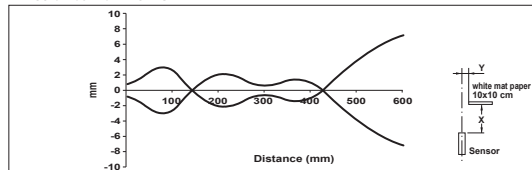

Emission cone

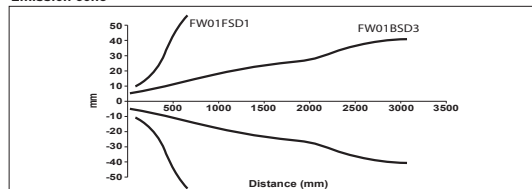

Chromatic sensitivity background suppression FW01BSD3

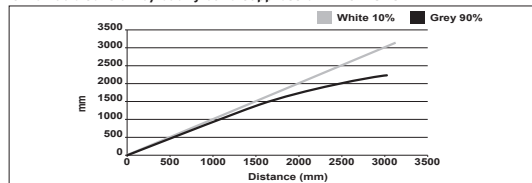

Chromatic sensitivity foreground suppression FW01FSD1

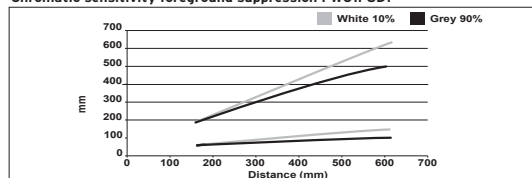



PHOTOELECTRIC SENSORS

BACKGROUND AND FOREGROUND SUPPRESSION 15÷230 V AC/DC - RELAY OUTPUT

- Rectangular housing
- Switching distance: 300 cm
- Detecting black targets on white background
- Insensitive to colours
- Foreground suppression
- Conduit wiring terminal block



FW Series



IDENTIFICATION CODE

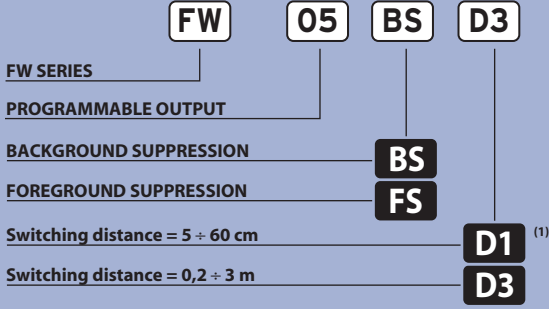

(1) Available only with option FS - not available with option BS

AVAILABLE	D1	D3
NOMINAL SWITCHING DISTANCE (Sn)	60 cm (1)	2 m (1) (On White Target 3 m (1))
TOLERANCE		+10/-10 %Sn
HYSTERESIS		< 5%
EMISSION		880 nm
NOMINAL VOLTAGE		15 ÷ 230 V AC/DC (-15 /+10%)
NET FREQUENCY		45 ÷ 60 Hz
OUTPUT		Relay (40x10 ⁶ mec. op. -5x10 ⁶ elect. op.)
MAX OUTPUT CURRENT		3A 250 VAC - 3A 30 VDC
ABSORPTION		2W (2,5 V A)
YELLOW LED		Light on indicator
GREEN LED		Supply indicator
SENSITIVITY ADJUSTMENT		Present
SWITCHING FREQUENCY		10 Hz
RESPONSE TIME		50 ms
START UP DELAY		300 ms
TEMPERATURE LIMITS		-10 ÷ +60 °C
LIGHT IMMUNITY		> 10.000 Lux (2)
PROTECTION DEGREE		IP 66
CONNECTIONS		Screw
CABLE GUIDE		PG 13.5
HOUSING MATERIAL		Housing: ABS - Lenses: methacrylate
WEIGHT (Approximately)		110 g

(1) Determined with a white mat paper (cm 20 x 20).

(2) Determined with halogen tungsten lamp 3000 °K.

Note: for a proper use see norms at pages 18, 19, 20, 21 and 22.

WIRING DIAGRAMS

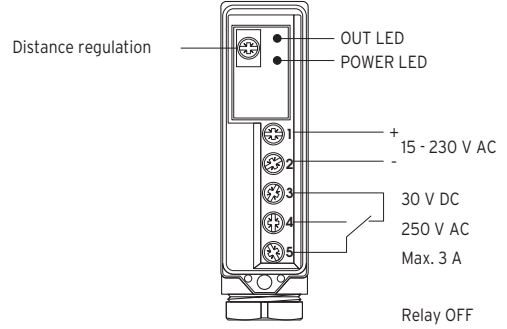

CHARACTERISTIC CURVES

Emission curve FW01BSD3

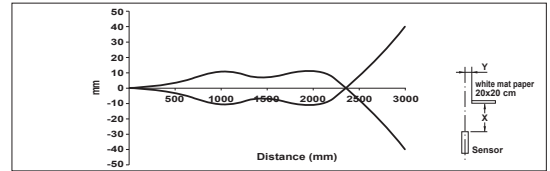

Emission curve FW01FSD1

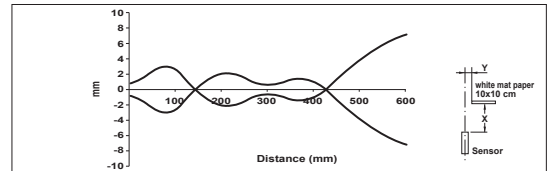

Emission cone

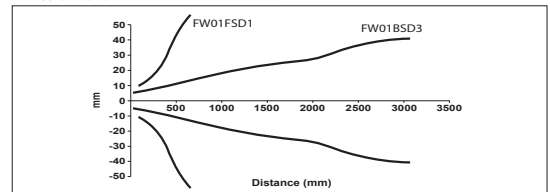

Chromatic sensitivity background suppression FW01BSD3

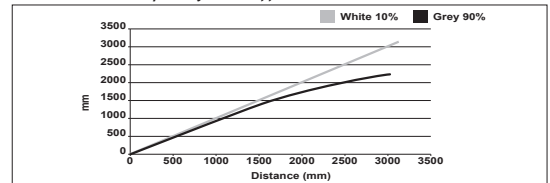

Chromatic sensitivity foreground suppression FW01FSD1

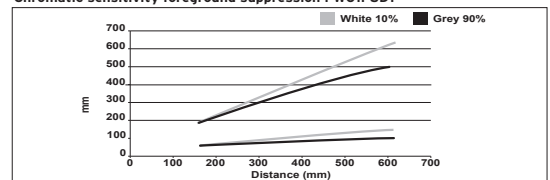

DIMENSIONS (mm)

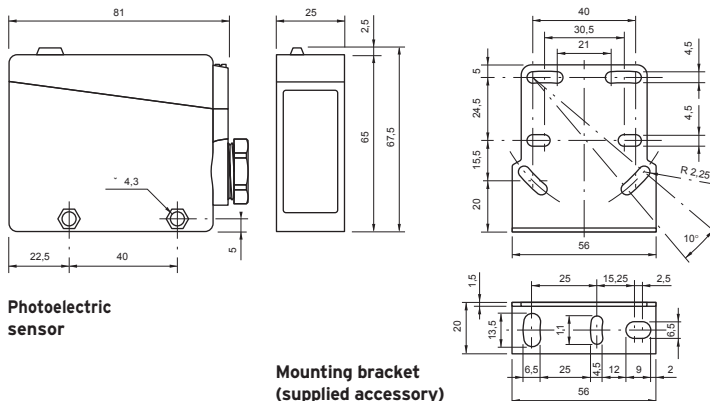



PHOTOELECTRIC SENSORS



RETRO REFLECTIVE 12÷30 V DC WITH PROGRAMMABLE OUTPUT

- Rectangular housing
- Multi-function timer
- ON/OFF delay
- One shot-four functions
- NPN or PNP programmable outputs
- Conduit wiring terminal block

FW Series



IDENTIFICATION CODE

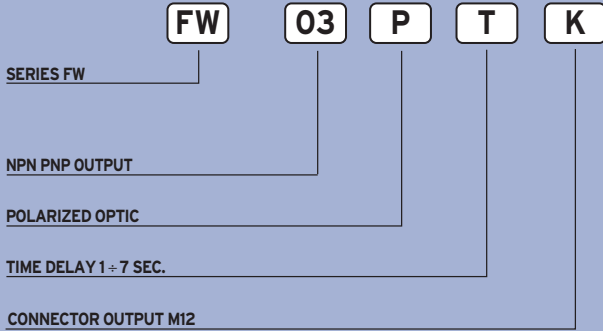

AVAILABLE	POLARIZED	STANDARD
NOMINAL SWITCHING DISTANCE (Sn)	9 m ⁽¹⁾	15 m ⁽¹⁾
TOLERANCE	+10/-10 %Sn	
HYSTERESIS	10%	
EMISSION	Red (660 nm)	Infrared (875 nm)
NOMINAL VOLTAGE	12 ÷ 30VDC (-15 /+10%)	
RESIDUAL RIPPLE	10%	
OUTPUT	NPN or PNP (programmable)	
MAX OUTPUT CURRENT	200 mA	
ABSORPTION	40 mA	
VOLTAGE DECREASE	2.5 VDC	
YELLOW LED	Light on indicator	
GREEN LED	Supply indicator	
SENSITIVITY ADJUSTMENT	Trimmer 1 turn	
TIME REGULATION	0.1 ÷ 7 s ± 2 s (only models with timer)	
SWITCHING FREQUENCY	200 Hz	
RESPONSE TIME	2.5 ms	
START UP DELAY	300 ms	
PROTECTION AGAINST SHORT-CIRCUIT	Present (self-resetting)	
TEMPERATURE LIMITS	-10° ÷ +60 °C	
LIGHT IMMUNITY	10.000 Lux ⁽²⁾	
PROTECTION DEGREE	IP 67	
CONNECTIONS	Screw or M12 conn.	
CABLE GUIDE	PG 13.5	
HOUSING MATERIAL	Housing: ABS - Lenses: methacrylate	
WEIGHT (Approximately)	110 g	

⁽¹⁾ Determined with CTO4S reflector.
⁽²⁾ Determined with halogen tungsten lamp 3000 °K.
 Note: for a proper use see norms at pages 18, 19, 20, 21 and 22.

WIRING DIAGRAMS

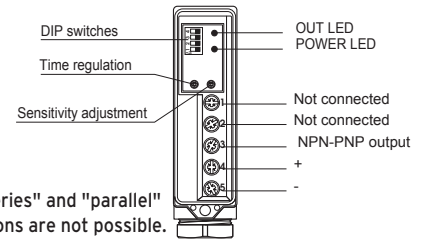

CONNECTION WITH CONNECTOR M12 (K)

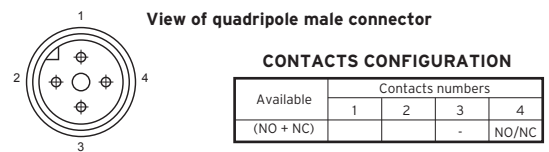

Note: Photoelectric sensor not suitable for use with 90° connectors.

TIMING DIAGRAMS

ALL MODELS

NO.	FUNCTION	DIP SWITCHES	OUTPUT DIAGRAM
1	Muting	ON	PNP = NO
		OFF	NPN = NO
MODELS WITHOUT TIMER			
1	Normally ON PNP	ON	PNP = NC
		OFF	NPN = NO
2	Normally ON NPN	ON	PNP = NO
		OFF	NPN = NC
MODELS WITH TIMER			
1	Delay on operate	ON	PNP = NC
		OFF	NPN = NO
2	Delay on operate	ON	PNP = NO
		OFF	NPN = NC
3	Delay on release	ON	PNP = NC
		OFF	NPN = NO
4	Delay on release	ON	PNP = NO
		OFF	NPN = NC
1	One shot leading edge	ON	PNP = NC
		OFF	NPN = NO
2	One shot leading edge	ON	PNP = NO
		OFF	NPN = NC
3	One shot trailing edge	ON	PNP = NC
		OFF	NPN = NO
4	One shot trailing edge	ON	PNP = NO
		OFF	NPN = NC

DIMENSIONS (mm)

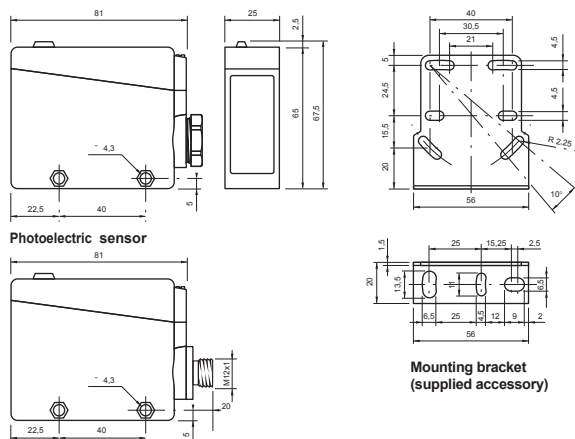

CHARACTERISTIC CURVES

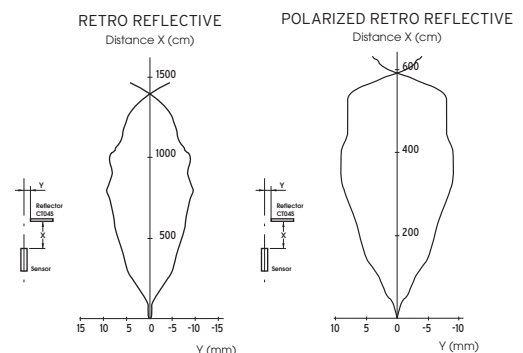



PHOTOELECTRIC SENSORS



RETRO REFLECTIVE

14÷230 V AC/DC WITH TIMER RELAY OUTPUT

- Rectangular housing
- Wide range Power Supply
- Multi-function timer
- ON/OFF delay
- One shot-four functions
- Conduit wiring terminal block

FW Series



IDENTIFICATION CODE

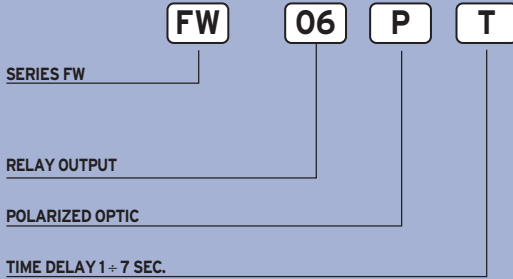

AVAILABLE	POLARIZED	STANDARD
NOMINAL SWITCHING DISTANCE (Sn)	9 m ⁽¹⁾	15 m ⁽¹⁾
TOLERANCE	+10/-10 %Sn	
HYSTERESIS	10%	
EMISSION	Red (660 nm)	Infrared (875 nm)
NOMINAL VOLTAGE	14 ÷ 230 VAC - DC (-15 /+10%)	
NET FREQUENCY	45 ÷ 60 Hz	
OUTPUT	Relay (40 x 10 ⁶ mec. op. - 5 x 10 ⁶ elect. op.)	
MAX OUTPUT CURRENT	3A 250VAC - 3A 30VDC	
ABSORPTION	2W (2.5 VA)	
YELLOW LED	Light on indicator	
GREEN LED	Supply indicator	
SENSITIVITY ADJUSTEMENT	Trimmer 1 turn	
TIME REGULATION	0.1 ÷ 7 s ± 2 s (only models with timer)	
SWITCHING FREQUENCY	10 Hz	
RESPONSE TIME	50 ms	
START UP DELAY	300 ms	
TEMPERATURE LIMITS	-10 ÷ +60 °C	
LIGHT IMMUNITY	> 10.000 Lux ⁽²⁾	
PROTECTION DEGREE	IP 67	
CONNECTIONS	Screw	
CABLE GUIDE	PG 13.5	
HOUSING MATERIAL	Housing: ABS - Lenses: methacrylate	
WEIGHT (Approximately)	110 g	

⁽¹⁾ Determined with CTO4S reflector.

⁽²⁾ Determined with halogen tungsten lamp 3000 °K.

Note: for a proper use see norms at pages 18, 19, 20, 21 and 22.

WIRING DIAGRAMS

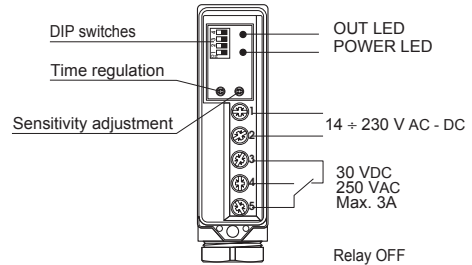

TIMING DIAGRAMS

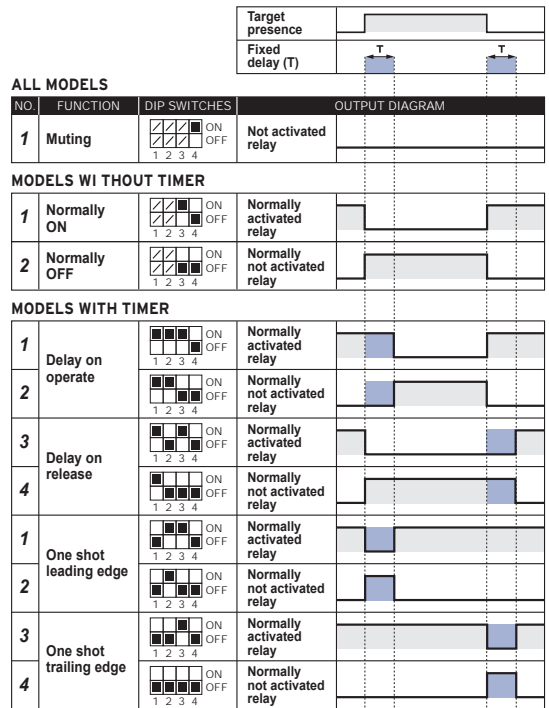

DIMENSIONS (mm)

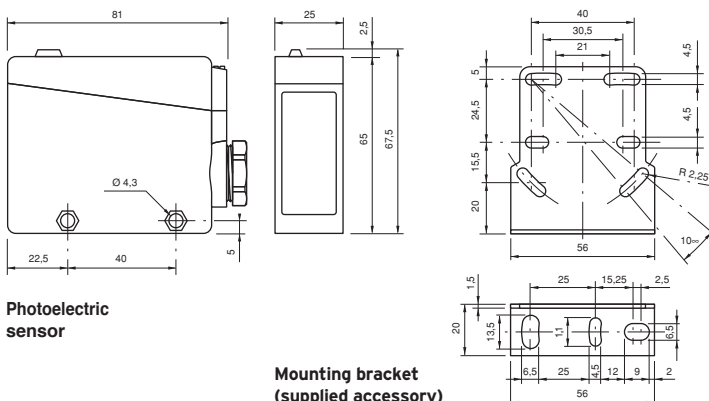

CHARACTERISTIC CURVES

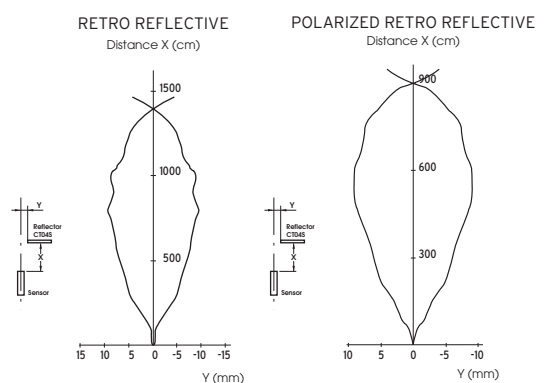

PHOTOELECTRIC



PHOTOELECTRIC SENSORS



THRU BEAM

14÷230 V AC/DC - TIMER RELAY OUTPUT

- Rectangular housing
- Wide range Power Supply
- Multi-function timer
- ON/OFF delay
- One shot-four functions
- Connector PG13.5

FW Series



IDENTIFICATION CODE

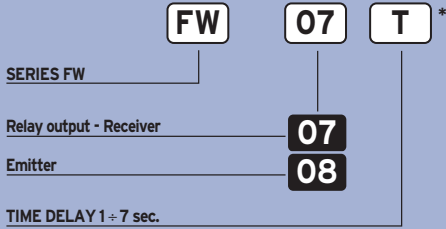

* "T" not available in FW08 model

AVAILABLE	RECEIVER	EMITTER
NOMINAL SWITCHING DISTANCE (Sn)	25 m	
TOLERANCE	+10/-10 %Sn	
HYSTERESIS	10%	
EMISSION	-	Infrared (875 nm)
NOMINAL VOLTAGE	14 ÷ 230VAC - DC (-15 /+10%)	
NET FREQUENCY	45 ÷ 60 Hz	
OUTPUT	Relay (40 x 10 ⁶ mec. op. -5 x 10 ⁶ elect. op.)	
MAX OUTPUT CURRENT	3A 250VAC - 3A 30VDC	-
ABSORPTION	2W (2.5 VA)	
YELLOW LED	Light on indicator	
GREEN LED	Supply indicator	
SENSITIVITY ADJUSTEMENT	Present	-
TIME REGULATION	0.1 ÷ 7 s ± 2 s (only models with timer)	-
SWITCHING FREQUENCY	10 Hz	
RESPONSE TIME	50 ms	-
START UP DELAY	300 ms	-
TEMPERATURE LIMITS	-10 ÷ +60 °C	
LIGHT IMMUNITY	10.000 Lux ⁽¹⁾	
PROTECTION DEGREE	IP 67	
CONNECTIONS	Screw	
CABLE GUIDE	PG 13.5	
HOUSING MATERIAL	Housing: ABS - Lenses: methacrylate	
WEIGHT (Approximately)	110 g	

⁽¹⁾ Determined with halogen tungsten lamp 3000 °K.
Note: for a proper use see norms at pages 18, 19, 20, 21 and 22.

WIRING DIAGRAMS

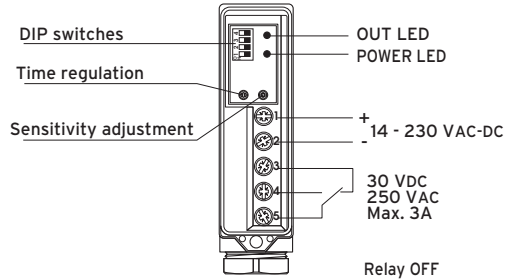

TIMING DIAGRAMS

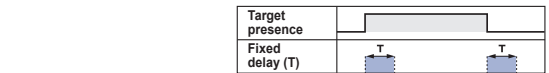

ALL MODELS

NO.	FUNCTION	DIP SWITCHES	OUTPUT DIAGRAM
1	Muting	<input type="checkbox"/> ON <input type="checkbox"/> OFF	Not activated relay

MODELS WITHOUT TIMER

1	Normally ON	<input type="checkbox"/> ON <input type="checkbox"/> OFF	Normally activated relay
2	Normally OFF	<input type="checkbox"/> ON <input type="checkbox"/> OFF	Normally not activated relay

MODELS WITH TIMER

1	Delay on operate	<input type="checkbox"/> ON <input type="checkbox"/> OFF	Normally activated relay
2		<input type="checkbox"/> ON <input type="checkbox"/> OFF	Normally not activated relay
3	Delay on release	<input type="checkbox"/> ON <input type="checkbox"/> OFF	Normally activated relay
4		<input type="checkbox"/> ON <input type="checkbox"/> OFF	Normally not activated relay
1	One shot leading edge	<input type="checkbox"/> ON <input type="checkbox"/> OFF	Normally activated relay
2		<input type="checkbox"/> ON <input type="checkbox"/> OFF	Normally not activated relay
3	One shot trailing edge	<input type="checkbox"/> ON <input type="checkbox"/> OFF	Normally activated relay
4		<input type="checkbox"/> ON <input type="checkbox"/> OFF	Normally not activated relay

DIMENSIONS (mm)

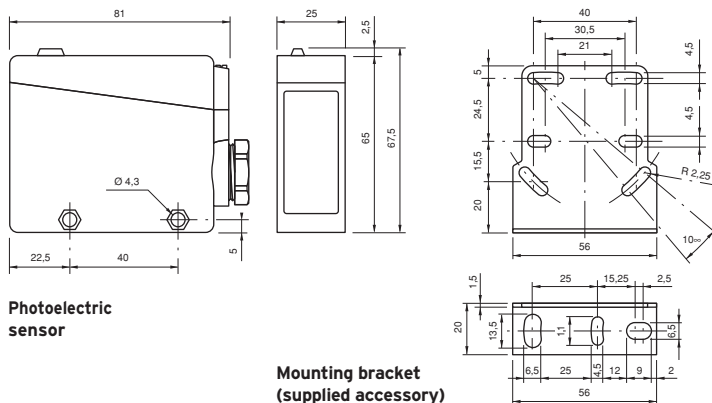

CHARACTERISTIC CURVES

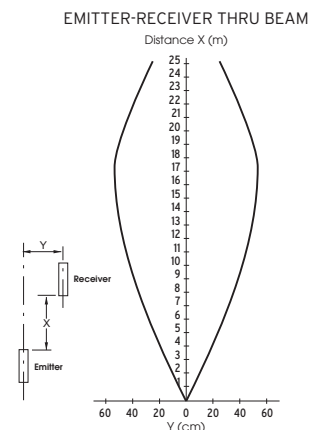



CONTRAST SENSORS

MARK READERS

10÷30 V DC - SOLID STATE AND ANALOGIC OUTPUT

- Teach-in
- Red/green LED emission
- Vertical or horizontal spot
- Remote setting
- Models with Auto-Set
- Long operation life
- Metal housing with orientable optic



MR Series



IDENTIFICATION CODE

MR90 **V** **C***

CONTRAST SENSOR

Vertical spot

V

Horizontal spot

H

2m CABLE OUTPUT - OPTIONAL -

* M12 connector is the sensor standard output.
For ordering the cable output model, add the "C" option to the chosen code.

NOTE: Standard output PNP NPN selectable

PRODUCT DESCRIPTION

CONSUMPTION	80 mA max.
LIGHT EMISSION	red 635 nm / green 565 nm LED
SPOT DIMENSION	1.5 x 5 mm (9 mm lens)
OPERATING DISTANCE (indicates e the typical detection distance)	6 ... 12 mm (9 mm lens)
DEPTH OF FIELD	±3 mm (9 mm lens)
SETTING	Teach-in with 2 push-buttons
INDICATORS	red OUTPUT LED / green READY LED
OUTPUT TYPE	NPN or PNP, Pull-down/up 10 K ohm
SATURATION VOLTAGE	1 V max. (NPN vers.) 2 V max. (PNP vers.)
OUTPUT CURRENT	200 mA max., short-circuit protection
RESPONSE TIME	50 µs max.
SWITCHING FREQUENCY	10 kHz max.
OPERATING MODE	automatic dark/light selection
ANALOG OUTPUT RANGE	0 ... 5.5 Vdc (2 Vdc on white 90%) 2.2 K ohm out. resistance
TIMING FUNCTION	20 ms minimum output ON
CONNECTION	M12 4-pole connector
ELECTRICAL PROTECTION	class 1
MECHANICAL PROTECTION	IP 67
HOUSING MATERIAL	ZAMA
LENS MATERIAL	Glass
WEIGHT	310 g max. (connector vers.)
OPERATING TEMPERATURE	-10 ÷ +55 °C
STORAGE TEMPERATURE	-25 ÷ +70 °C

WIRING DIAGRAMS

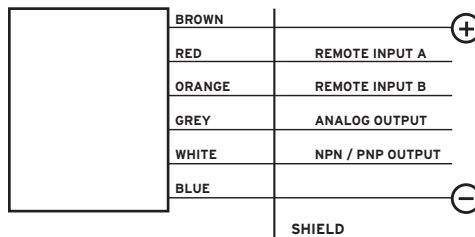

CONNECTION WITH CONNECTOR M12 (K)

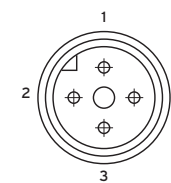

View of quadripole male connector.

CONTACTS CONFIGURATION

	Contacts numbers			
	1	2	3	4
Wires connections	+	Analog output	-	NPN/PNP output
Wires colours	BROWN	WHITE	BLUE	BLACK

DETECTION DIAGRAM

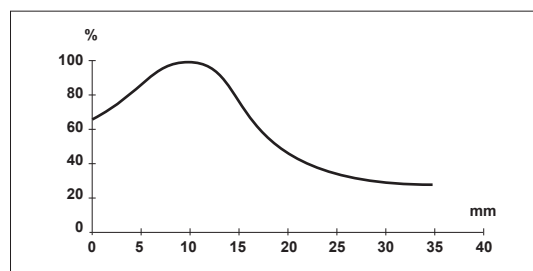

The detection diagram indicates the typical operating distance.

DIMENSIONS (mm)

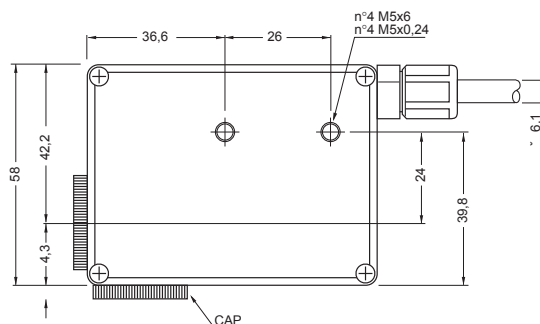
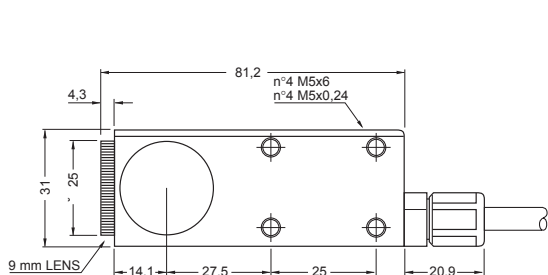



CONTRAST SENSORS



10÷30 V DC MARK READERS SOLID STATE OUTPUT

- M12 4 poles connector output
- High switching frequency
- Sturdy plastic housing
- Vertical spot
- RGB LED emission with automatic selection
- Easy automatic setting

MR100 Series



IDENTIFICATION CODE

MR 100

V

CONTRAST SENSOR

Vertical spot

V

* M12 connector is the sensor standard output.

PRODUCT DESCRIPTION

POWER SUPPLY	10÷30 VDC, reverse polarity protection
CONSUMPTION	50 mA max. at 24 VDC
LIGHT EMISSION	RGB LED (435 nm blu , 520 nm green , 630 nm red)
SPOT DIMENSION	1.5 x 5 mm (9 mm lens)
OPERATING DISTANCE (indicates e the typical detection distance)	9 mm (9 mm lens)
DEPTH OF FIELD	±3 mm (9 mm lens)
SETTING	automatic (MARK push button, BKGD push button)
INDICATORS	yellow OUTPUT LED / green READY LED / orange DELAY LED
OUTPUT TYPE	NPN or PNP, bipolar output
SATURATION VOLTAGE	≤2 V
OUTPUT CURRENT	100 mA max., short-circuit protection
RESPONSE TIME	33 μs max.
SWITCHING FREQUENCY	15 kHz max.
OPERATING MODE	automatic dark/light selection
TIMING FUNCTION	0...20 ms selectable
CONNECTION	M12 4-pole connector
INSULATION	20 MOhm 500 VDC
MECHANICAL PROTECTION	IP 67
HOUSING MATERIAL	ABS
LENS MATERIAL	PMMA
WEIGHT	90 g max.
OPERATING TEMPERATURE	-10 ... +55°C
STORAGE TEMPERATURE	-25 ... +70°C

WIRING DIAGRAMS

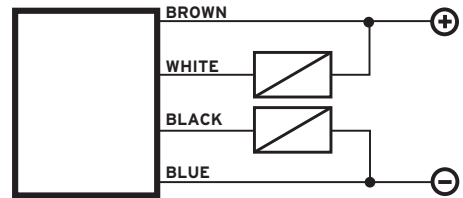

CONNECTION WITH CONNECTOR M12

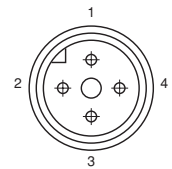

View of quadripole male connector.

CONTACTS CONFIGURATION

	Contacts numbers			
	1	2	3	4
Wires connections	+	NPN output	-	PNP output
Wires colours	BROWN	WHITE	BLUE	BLACK

DETECTION DIAGRAM

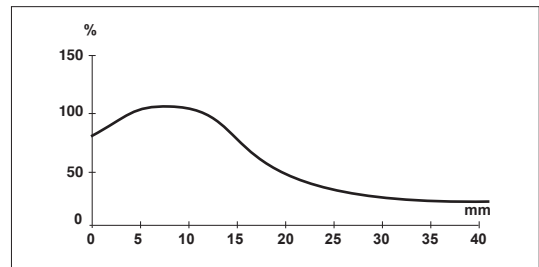

The detection diagram indicates the typical operating distance with standard 9 mm lens

DIMENSIONS (mm)

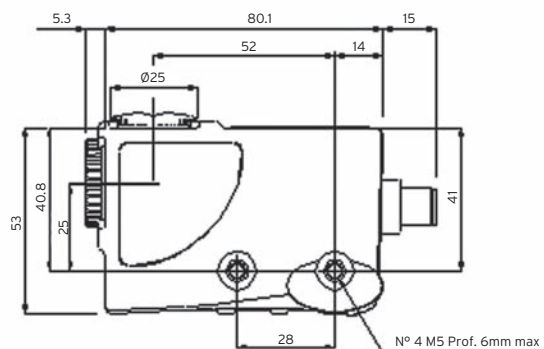
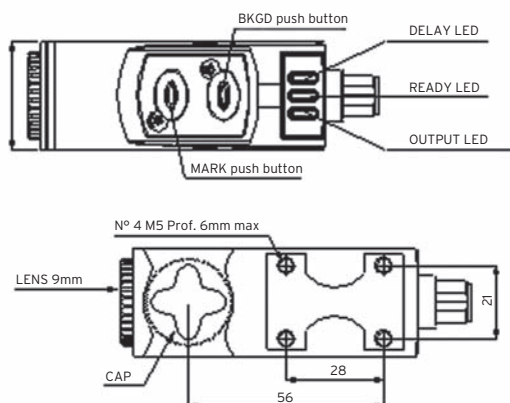

PHOTOELECTRIC SENSORS

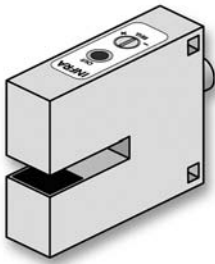

OPTICAL BRACKETS

12÷30 V DC - NPN OR PNP NO - NC OUTPUT

- 5 mm wide X 29 mm deep slot
- 9-turn sensitivity adjuster
- Operation LED indicator
- 2 m integral cable
- Plastic housing
- Infrared emitter

FF Series



IDENTIFICATION CODE

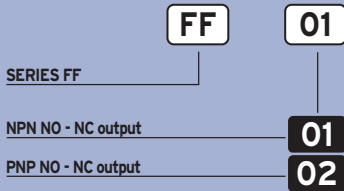

PRODUCT DESCRIPTION

CLEF	5 mm
EMISSION	Infrared (875 nm)
NOMINAL VOLTAGE	12 ÷ 30V DC (-15 /+10%)
RESIDUAL RIPPLE	10%
MAX. OUTPUT CURRENT	200 mA
ABSORPTION AT 30 V DC	30 mA
VOLTAGE DROP (Sensor ON)	< 1.5 V (I = 100 A)
OPERATION LED	Present
SENSITIVITY ADJUSTEMENT	Trimmer 9 turns
SWITCHING FREQUENCY	200 Hz
RESPONSE TIME	2.5 ms
START UP DELAY	200 ms
SHORT CIRCUIT PROTECTION	Present (self-resetting)
ELECTRIC PROTECTIONS	Against polarity reversal - inductive loads
TEMPERATURE LIMITS	- 10 ÷ +60 °C
LIGHT IMMUNITY	2.000 Lux ⁽¹⁾
PROTECTION DEGREE	IP 65
CABLE LENGTH	2 m
CABLE SECTION	4 x 0.25 mm ²
HOUSING MATERIAL	Housing: nylon loaded with fiberglass - Lenses: methacrylate
WEIGHT (Approximatev)	110 g

⁽¹⁾ Determined with halogen tungsten lamp 3000 °K.
Note: for a proper use see norms at pages 18, 19, 20, 21 and 22.

WIRING DIAGRAMS

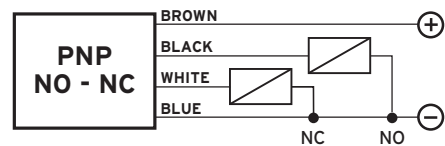
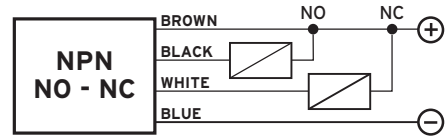

ADJUSTMENT

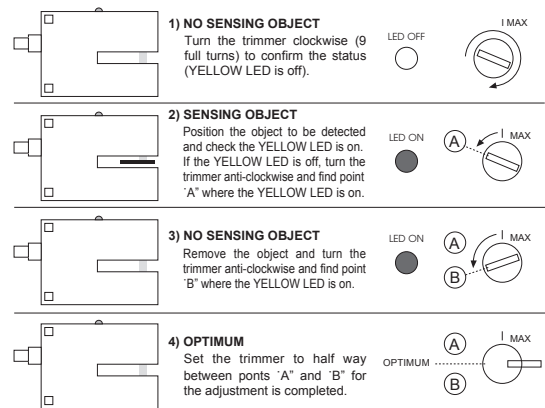

Note: for proper use see norms at pages 7, 8, 9 and 10.

DIMENSIONS (mm)

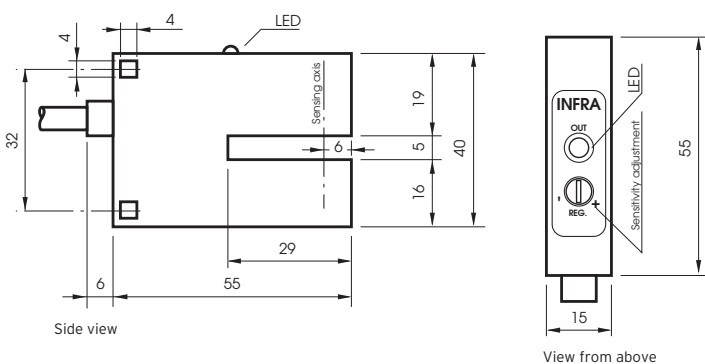

SENSITIVITY ADJUSTMENT

- 1) SENSITIVITY INCREASE**
Screw the trimmer towards right toward position "+"
- 2) SENSITIVITY DECREASE**
Screw the trimmer towards left toward position "-"

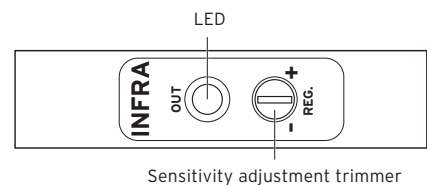

Note: the trimmer needs 9 turns.

PHOTOELECTRIC

PHOTOELECTRIC SENSORS

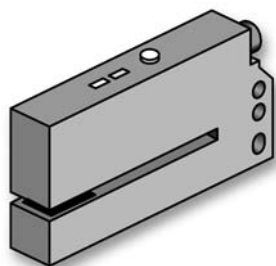

TEACH-IN OPTICAL BRACKETS 12÷30 V DC - PROGRAMMABLE OUTPUT

- 3 mm gap X 60 mm deep for flexible installation
- Teach-in standard or sensitive calibration automatically sets sensitivity values
- Fast response time: 10 K Hz switching frequency
- Remote Teach-in allows fast target changeover by the host
- Applications include: Translucent material - Double detection - Edge detection

FF Series



IDENTIFICATION CODE

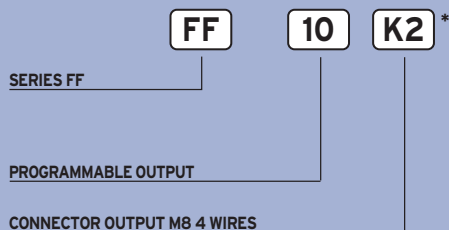

* Available only with K2 connector output

PRODUCT DESCRIPTION

CLEF	3 mm
EMISSION	Infrared (875 nm)
NOMINAL VOLTAGE	12 ÷ 30V DC (-15 /+10%)
RESIDUAL RIPPLE	10%
OUTPUT	Programmable NPN or PNP
MAX OUTPUT CURRENT	100 mA
ABSORPTION AT 30 V DC	40 mA
VOLTAGE DROP (Sensor ON)	2 V (I = 100 mA)
RED LED	Memorization - Standard teach-in
GREEN LED	Object presence/absence - Thin teach-in
SWITCHING FREQUENCY	10.000 Hz
RESPONSE TIME	50 ms
START UP DELAY	100 ms
SHORT CIRCUIT PROTECTION	Present (self-resetting)
ELECTRIC PROTECTIONS	Against polarity reversal
TEMPERATURE LIMITS	-10 ÷ +60 °C
LIGHT IMMUNITY	3.000 Lux
PROTECTION DEGREE	IP 65
CABLE SECTION	M8 4 wires connector
HOUSING MATERIAL	Anodised aluminium
WEIGHT (Approximatev)	85 g

Note: for a proper use see norms at pages 18, 19, 20, 21 and 22.

WIRING DIAGRAMS

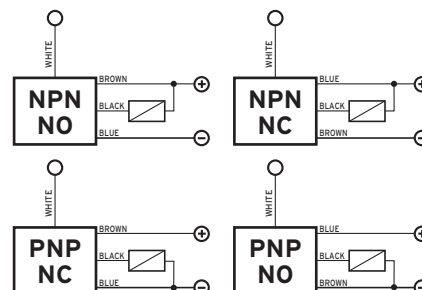

Note: If the white wire is not used for external teach-in, connect it to ground.

WIRING DIAGRAMS WITH M8 CONNECTOR (K)

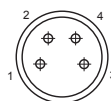

View of quadripole male connector.

CONTACTS CONFIGURATION

Output	Contacts numbers			
	1	2	3	4
NPN/PNP NO	-	White	+	Out
NPN/PNP NC	+	White	-	Out

Note: Use only the female connector type K2FDV. If the contact n. 3 (white wire) is not used for external teach-in, connect it to ground.

DIMENSIONS (mm)

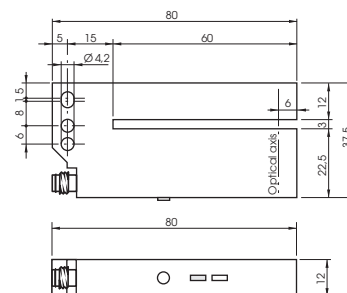

DIMENSIONS (mm)

STANDARD TEACH-IN (TO DETECT STANDARD TAGS)

PHOTOELECTRIC SENSOR POSITION

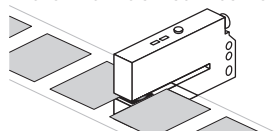

WARNING: The photoelectric sensor teach-in must be executed by placing the photoelectric sensor on the tag traslucid support (not directly on the tag which has to be detected).

- 1) Set the optical bracket on the tag support.
- 2) Push once the button: the red led light will be blinking through 2 seconds.
- 3) Push again the adjustment button and keep it pushed till the definitive switching of the red led (memorization achieved).

Warning: if during the adjustment the red led and the green led are blinking at the same moment, it means that a short-circuit occurs at the output or that the tag support is too opaque.

STATUS LED

RED LED BLINKING THROUGH 2 SECONDS	
RED LED ON	
RED AND GREEN LEDS BLINKING	

THIN TEACH-IN (TO DETECT TRASLUCLIDE TAGS)

PHOTOELECTRIC SENSOR POSITION

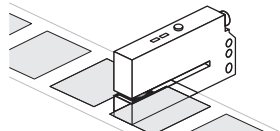

WARNING: The photoelectric sensor teach-in must be executed by placing the photoelectric sensor on the tag traslucid support (not directly on the tag which has to be detected).

- 1) Set the optical bracket on the tag support.
- 2) Push twice the button: the green led light will be blinking through 2 seconds.
- 3) Push again the adjustment button and keep it pushed till the definitive switching of the red led (memorization achieved).

Warning: if during the adjustment the red led and the green led are blinking at the same moment, it means that a short-circuit occurs at the output or that the tag support is too opaque.

LED DI STATO

GREEN LED BLINKING THROUGH 2 SECONDS	
RED LED ON	
RED AND GREEN LEDS BLINKING	

The same teach-in mode achieved by pushing the button can be also obtained by connecting the white wire to the positive (external teach-in), following the same steps envisaged for teach-in through the button. For a correct installation see norms at pages 7, 8, 9 and 10

PHOTOELECTRIC SENSORS



AMPLIFIER FOR OPTICAL FIBERS

12÷30 V DC - 3 WIRES PROGRAMMABLE OUTPUT

- High sensing distance
- Programmable output NPN-PNP
- Friendly adjustment by KEY +/-



AF Series



IDENTIFICATION CODE

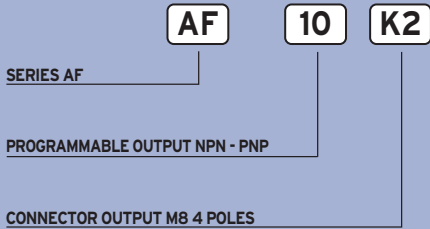

PRODUCT DESCRIPTION

EMISSION	Red
NOMINAL VOLTAGE	12 ÷ 30VDC
RESIDUAL RIPPLE	< 10%
OUTPUT	NPN - PNP (PROGRAMMABLE)
MAX OUTPUT CURRENT	100 mA
ABSORPTION AT 30 VDC	< 40 mA
VOLTAGE DROP (Sensor ON)	< 2 V (I= 100 mA)
YELLOW LED	Present
SENSITIVITY ADJUSTMENT	By key +/-
SWITCHING FREQUENCY	1000 Hz
RESPONSE TIME	500 ms
START UP DELAY	300 ms
SHORT CIRCUIT PROTECTION	Present (self resetting)
ELECTRIC PROTECTION	Against polarity reversal - inductive loads
TEMPERATURE LIMITS	0 ÷ +60 °C
LIGHT IMMUNITY	10000 Lux ⁽¹⁾
PROTECTION DEGREE	IP 65
CABLE LENGTH	2 m
CABLE SECTION	3 x 0.25 mm ²
HOUSING MATERIAL	ABS
WEIGHT	100 g

⁽¹⁾ Determined with halogen tungsten lamp 3000 °K.
Note: for a proper use see norms at pages 18, 19, 20, 21 and 22.

WIRING DIAGRAMS

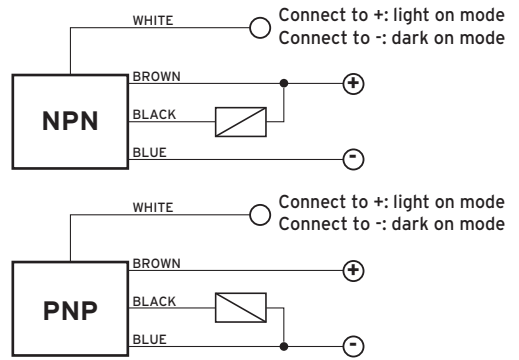

CONNECTION WITH CONNECTOR M8 (K2)

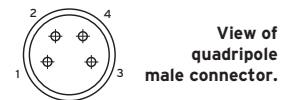

CONTACTS CONFIGURATION

Output	Contacts numbers			
	1	2	3	4
NPN/PNP light ON	-	+	+	Out
NPN/PNP dark OFF	-	-	+	Out

VISUALISATION AND KEYBOARD

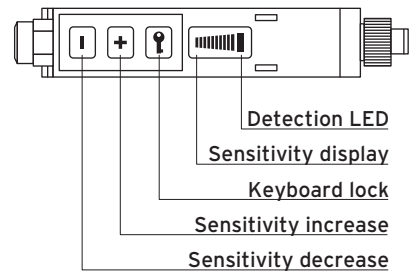

DIMENSIONS (mm)

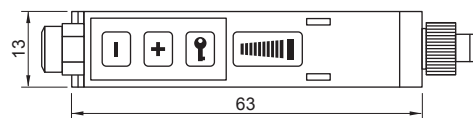
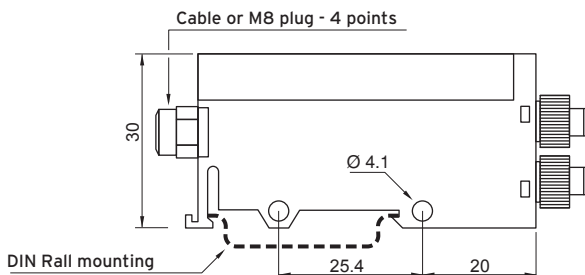

Note: optical fibers cutter supplied with the amplifier.

PHOTOELECTRIC

PHOTOELECTRIC SENSORS

PLASTIC OPTICAL FIBERS

DIFFUSE REFLECTIVE AND THRU BEAM MODELS

- Sensing distance: 80 mm Diffuse Reflective model
- Sensing distance: 200 mm Thru Beam model
- Use with amplifier AF10

FP Series



IDENTIFICATION CODE

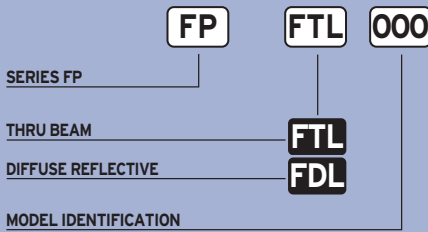

ADJUSTMENT PROCEDURES AND ASSEMBLING

1) AMPLIFIER UNIT

- Make sure that the supply voltage complies with the given value ($\pm 10\%$) for a stable functioning.
- The connection cables of the amplifier must be separated from the power cables in order to avoid interferences in the net.
- Temperature and humidity must be within the given limits.

2) SENSITIVITY ADJUSTMENT

- Even after the tuning, sensitivity may be slightly changed by the object to be detected and by environmental factors.
- Since the reflectivity changes according to the object, adjustment must be carried out using the object to be detected.
- Once the adjustment is completed, do not change the fixing or the bending radius.
- Make sure the adjustment has been carried out correctly.

3) OPTICAL FIBERS

- Plastic fibers can be cut with the proper fiber cutter in the desired length.
- Cut the fibers before connecting them and be sure that the cut is perfect in order to avoid decrease of sensitivity.
- Do not use the same cutting hole for more than one cut.

FIXING TORQUE	
M 3	6 Kgf - cm MAX.
M 4	10 Kgf - cm MAX.
M 5	10 Kgf - cm MAX.

4) FIBER FIXING

- Use the supplied nuts and washers. When screwing pay attention not to damage the fiber with excessive forcing.
- When fixing the smooth (not threaded) type of fiber, use a M3 max. screw and do not exceed torque force of 3 kg/cm 2 max.

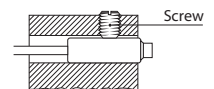

DIFFUSE REFLECTIVE SELECTION TABLE

CODE	CABLE LENGTH	DIMENSIONS	SWITCHING DISTANCE	TYPE OF FIBER
FPFDL010	2000	<p>Possible cutting</p>	80 mm	●
FPFDL110	2000	<p>Possible cutting</p>	30 mm	●
FPFDL100	2000	<p>Not possible cutting</p>	10 mm	●
FPFDL310	2000	<p>Possible cutting</p>	30 mm	●

THRU BEAM SELECTION TABLE

CODE	CABLE LENGTH	DIMENSIONS	SWITCHING DISTANCE	TYPE OF FIBER
FPFTL000	2000	<p>Possible cutting</p>	200 mm	●
FPFTL200	2000	<p>Not possible cutting</p>	100 mm	●
FPFTL301	2000	<p>Possible cutting</p>	200 mm	●

CHARACTERISTIC CURVES

Diffuse Reflective

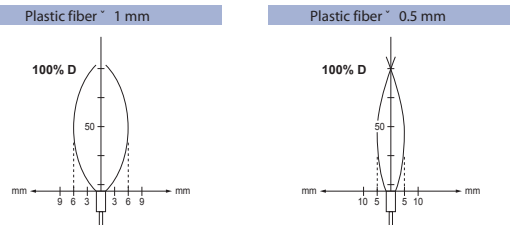

Thru Beam

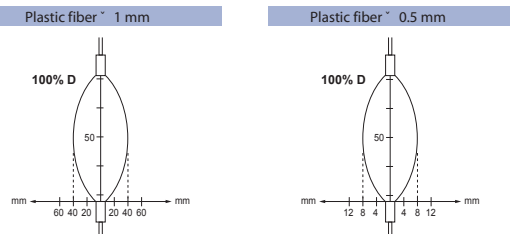

ACCESSORIES

FOR PHOTOELECTRIC SENSORS M12 M18 AND M30

- Ray turner 90° for all M18 photoelectric sensors
- Shutter for all M18 emitter-receiver thru beam
- Mounting brackets for M12 - M18 and M30 sensors

DEV-P18-ST Series



ACCESSORY FOR READING AT 90° (Art. DEV90)

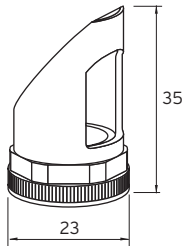

Ray turner for 90° sensing of cylindrical photoelectric sensors M 18. It can be used for DIFFUSE REFLECTIVE, RETRO REFLECTIVE, POLARIZED RETRO REFLECTIVE, EMITTERS AND RECEIVERS THRU BEAM systems.

Weight 7 g

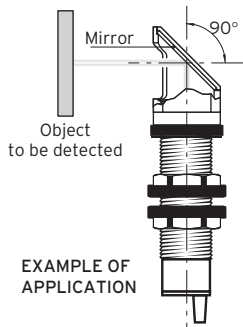

WARNING

The ray turner determines an attenuation of the switching distance that can be computed as follows:

$$DR = \frac{D - 2}{100} \times 80$$

where "D" is the sensor switching distance indicated in cm and "DR" is the real switching distance indicated in cm.

SHUTTER FOR EMITTER-RECEIVER THRU BEAM (Art. P18OTT)

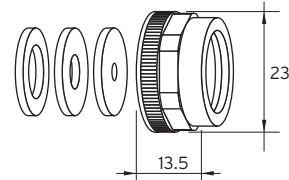

WARNING:

each package contains three shutter disks

Weight 5 g

Accessory to detect small size objects with emitter-receiver cylindrical thru beam M18.

SHUTTING DIAM.	MIN. OBJECT TO BE DETECTED	DISTANCE ATTENUATION
2 mm	≥ 2 mm	97 %
4 mm	≥ 4 mm	84 %
8 mm	≥ 8 mm	54%

WARNING:

the datum "Minimum object to be detected" refers to the condition of shutter mounted on emitter receiver.

EXAMPLE OF APPLICATION

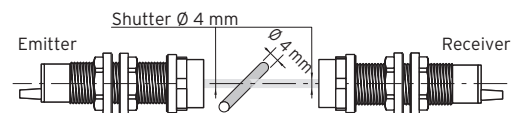

MOUNTING BRACKETS FOR M12, M18 SENSORS (Art. ST1218)

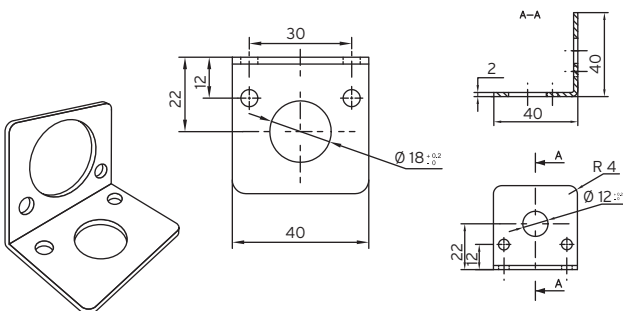

Material: stainless steel.

Weight 40 g

MOUNTING BRACKETS FOR M18, M30 SENSORS (Art. ST1830)

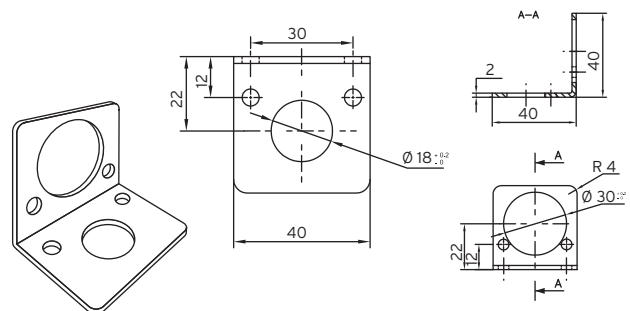

Material: stainless steel.

Weight 40 g

ACCESSORIES

FOR PHOTOELECTRIC SENSORS RECTANGULAR AND ROUND REFLECTORS

- High performance
- Round models
- Rectangular models

CT Series



RECTANGULAR TYPE (Art. CT05)

Thickness: 8,4 mm
Weight 10 g

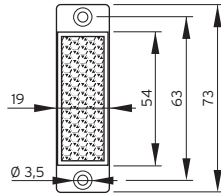

ROUND TYPE (Art. CT01)

Thickness: 6 mm
Weight 1 g

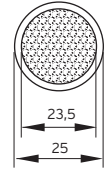

RECTANGULAR TYPE (Art. CT07)

Thickness: 8 mm
Weight 10 g

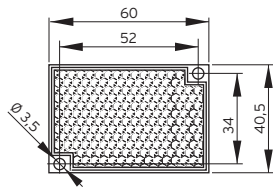

ROUND TYPE (Art. CT02)

Thickness: 7.5 mm
Weight 4 g

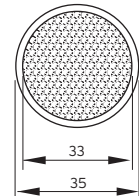

RECTANGULAR TYPE (Art. CT100)

Thickness: 9 mm
Weight 40 g

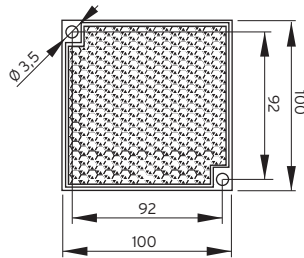

ROUND TYPE (Art. CT03)

Thickness: 6,5 mm
Weight 1 g

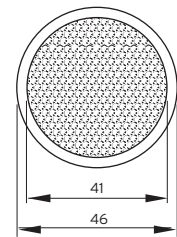

RECTANGULAR TYPE (Art. CT150)

Thickness: 7,4 mm
Weight 30 g

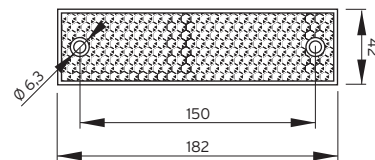

RECTANGULAR TYPE (Art. CT08B)

CT08BRT
914 mm x 1000 mm sheet

NOTE: Models CT08B and CT08BRT are suitable for Polarised photocells.

Thickness: 1 mm
Weight 32 g

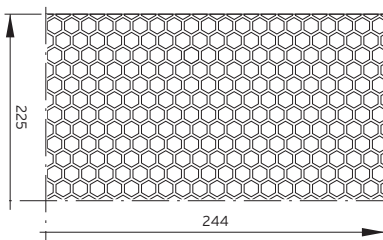

ROUND TYPE WITH FIXING HOLES TYPE (Art. CT04S)

Thickness: 8 mm
Weight 25 g

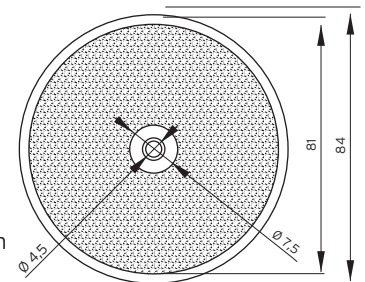

ROUND TYPE WITH FIXING HOLES TYPE (Art. CT06)

Thickness: 6,5 mm
Weight 6 g

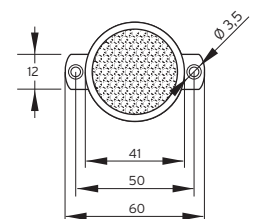

The reflection distance for all models is referred to CT04S as 100%. When other models or reflectors are used, the distance results different. See the picture.

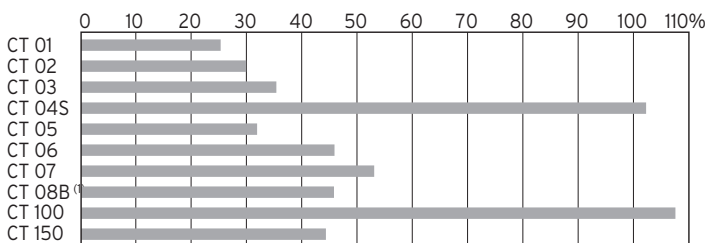

Note: (1) 80 x 80 mm

ACCESSORIES

FEMALE CONNECTORS WITH CABLE

M12 - 3 AND 4 WIRES

Suitable for:

- 18, MD, FQ series photocells (K output)
- IS and ISM series inductive sensors (K output)

K Series



M12 4 WIRES IDENTIFICATION CODE

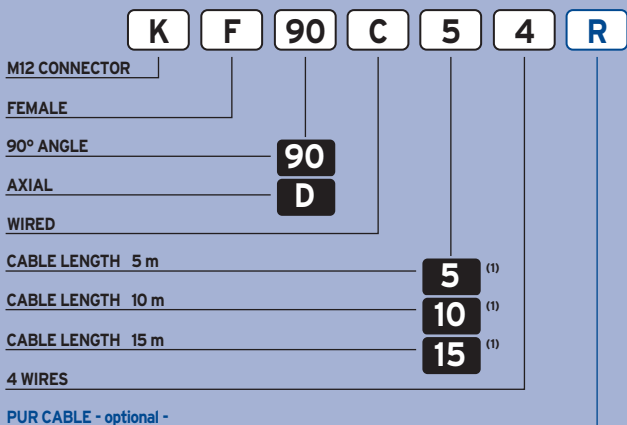

⁽¹⁾ Note: other cable length, from 1 m up to 40 m, available on request.

M12 3 WIRES WITH LED IDENTIFICATION CODE

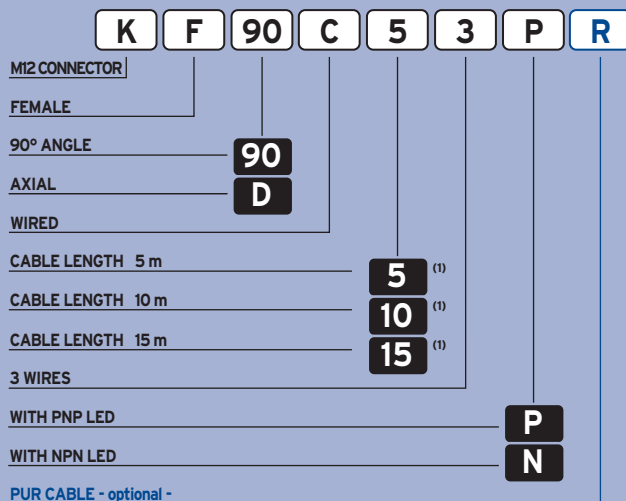

DIMENSIONS (mm)

View of M12 straight female connector

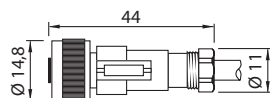

View of M12 90+ female connector

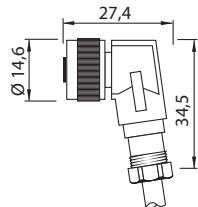

CONTACTS CONFIGURATION

M12 3 wires female connector

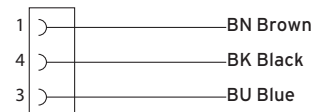

M12 4 wires female connector

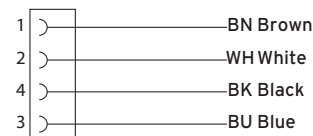

TECHNICAL DATA OF M12 FEMALE CONNECTORS

	PVC CABLE	PUR CABLE
CONNECTOR POLARITY IN ACCORDANCE WITH IEC 61067-2 101	3 and 4 wires	3 and 4 wires
NOMINAL VOLTAGE IN ACCORDANCE WITH DIN VDE 0110 (III/3) E IEC 60664 -1	320 V DC / 250 V AC	320 V DC / 250 V AC
NOMINAL VOLTAGE	4 A	4 A
CONTACT RESISTANCE	< 5 m Ω	< 5 m Ω
TEST VOLTAGE IN ACCORDANCE WITH DIN VDE 0110	2,5 KV	2,5 KV
CONTACTS MATERIAL	CuSn	CuSn
CONTACTS SURFACE COVERING MATERIAL	Au	Au
CONNECTOR MATERIAL	TPU (thermoplastic polyurethane) hardly	self inflammable and self extinguish
CONNECTOR COLOUR	Grey - RAL 7035	Grey - RAL 7035
CONNECTOR USE TEMPERATURE	-25° / +90°C	-25° / +90°C
PROTECTION DEGREE IN ACCORDANCE WITH EN 60529 (IEC 60529 AND DIN VDE 0470-1)	IP 67	IP 67
WIRING NUT FEATURES	14,8 mm external dia, M12x1 threading	14,8 mm external dia, M12x1 threading
CABLE TYPE	PVC/PVC	PUR/PVC
EXTERNAL SLEEVE COLOUR	Grey - RAL 7001	Grey - RAL 7001
CABLE EXTERNAL DIAMETER	3 and 4 wires = 5,2 mm (± 0,2 mm)	3 and 4 wires = 5,2 mm (± 0,2 mm)
WIRES SLEEVE MATERIAL	PVC	PVC
NO. OF CONDUCTORS ON CABLE SECTION	3 x 0,34 mm ² and 4 x 0,34 mm ²	3 x 0,34 mm ² and 4 x 0,34 mm ²
WIRES COLOUR	in accordance with din DIN 0293	in accordance with din DIN 0293
CONDUCTORS STRUCTURE	42 x 0,1 mm in class 6	42 x 0,1 mm in class 6
CABLE BENDING RADIUS	15 times external diameter moving installation 10 times external diameter steady installation	15 times external diameter moving installation 10 times external diameter steady installation
TEMPERATURE LIMITS	-30°C / +70°C (steady installation)	-30°C / +90°C (steady installation)
ISOLATION VOLTAGE	2500 V; 50 Hz; 5 min.	2500 V; 50 Hz; 5 min.
CABLE MARKS	PVC/PVC UL/CSA	PUR/PVC UL/CSA
WEIGHT	5 m 190 g • 10 m 380 g • 15 m 520 g	

ACCESSORIES

FEMALE CONNECTORS WITH CABLE

M8 - 3 AND 4 WIRES

Suitable for:

- IS series inductive sensors (K1 output)
- MT, FF and AF series photocells (K2 output)
- CS series capacitive sensors (K2 output)

K Series



M8 4 WIRES IDENTIFICATION CODE

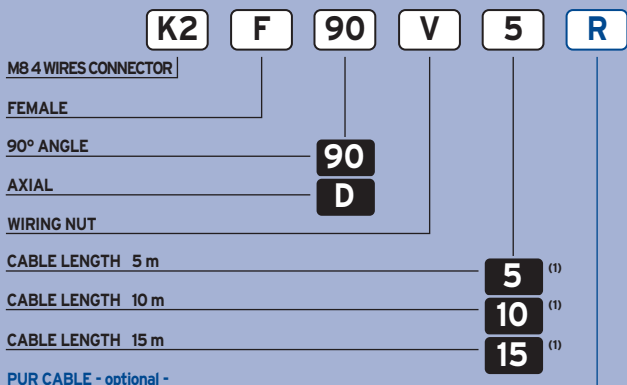

(1) Note: other cable length, from 1 m up to 40 m, available on request.
 (2) Note: available only for 90° models.

M8 3 WIRES WITH LED IDENTIFICATION CODE

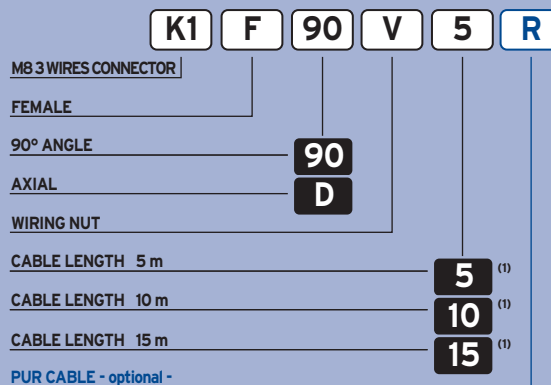

DIMENSIONS (mm)

View of M8 straight female connector

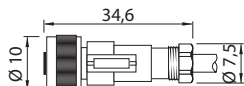

View of M8 90° female connector

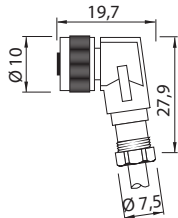

CONTACTS CONFIGURATION

M8 3 wires female connector

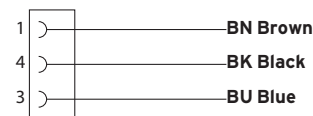
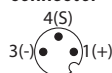

M8 4 wires female connector

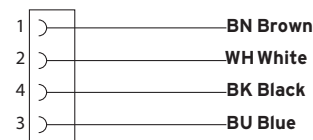

TECHNICAL DATA OF M8 FEMALE CONNECTORS

	PVC CABLE	PUR CABLE
CONNECTOR POLARITY IN ACCORDANCE WITH IEC 61067-2-101	3 and 4 wires	3 and 4 wires
NOMINAL VOLTAGE IN ACCORDANCE WITH DIN VDE 0110 (III/3) E IEC 60664-1	100 V dc (160 V in cat. II)	100 V dc (160 V in cat. II)
NOMINAL VOLTAGE	4 A	4 A
CONTACT RESISTANCE	< 5 m Ω	< 5 m Ω
TEST VOLTAGE IN ACCORDANCE WITH DIN VDE 0110	1,5 KV	1,5 KV
CONTACTS MATERIAL	CuSn	CuSn
CONTACTS SURFACE COVERING MATERIAL	Au	Au
CONNECTOR MATERIAL	TPU (thermoplastic polyurethane) hardly inflammable and self extinguish	
CONNECTOR COLOUR	Grey RAL 7035	Grey RAL 7035
CONNECTOR USE TEMPERATURE LIMITS	-25° / +90°C	-25° / +90°C
PROTECTION DEGREE IN ACCORDANCE WITH EN 60529 (IEC 60529 AND DIN VDE 0470-1)	IP 67	IP 67
WIRING NUT FEATURES	14,8 mm external dia, M8x1 threading	14,8 mm external dia, M8x1 threading
CABLE TYPE	PVC/PVC	PUR/PVC
EXTERNAL SLEEVE COLOUR	Grey RAL 7001	Grey RAL 7001
CABLE EXTERNAL DIAMETER	3 wires = 4,4 mm (± 0,2 mm) 4 wires = 4,7 mm (± 0,2 mm)	3 wires = 4,4 mm (± 0,2 mm) 4 wires = 4,7 mm (± 0,2 mm)
WIRES SLEEVE MATERIAL	PVC	PVC
NO. OF CONDUCTORS ON CABLE SECTION	3 x 0,25 mm ² and 4 x 0,25 mm ²	3 x 0,25 mm ² and 4 x 0,25 mm ²
WIRES COLOUR	in accordance with DIN 0293	in accordance with DIN 0293
CONDUCTORS STRUCTURE	32 x 0,1 mm in class 6	32 x 0,1 mm in class 6
CABLE BENDING RADIUS	15 times external diameter moving installation 10 times external diameter steady installation	15 times external diameter moving installation 10 times external diameter steady installation
TEMPERATURE LIMITS	-30°C / +70°C (steady installation)	-30°C / +90°C (steady installation)
ISOLATION VOLTAGE	2500 V; 50 Hz; 5 min.	2500 V; 50 Hz; 5 min.
CABLE MARKS	PVR/PVC UL/CSA	PUR/PVC UL/CSA
WEIGHT	5 m 150 g ~ 10 m 300 g ~ 15 m 450 g	

ACCESSORIES

CONNECTORS TO BE WIRED

M12 AND M8

K models suitable for:

- 18, MD, FQ series photocells (K output)
- IS and ISM series inductive sensors (K output)

K1 models suitable for:

- IS series inductive sensors (K1 output)

K Series



M12 4 WIRES IDENTIFICATION CODE

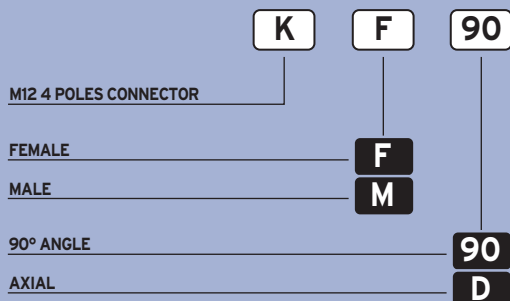

M12 3 WIRES WITH LED IDENTIFICATION CODE

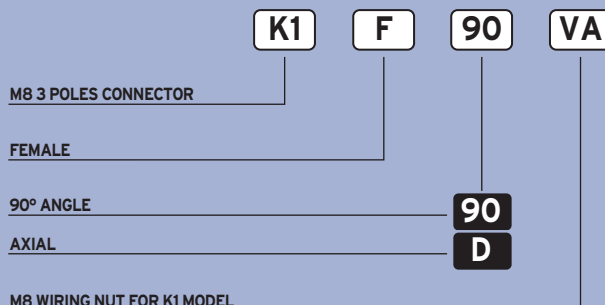

DIMENSIONS (mm) AND CONTACTS CONFIGURATION

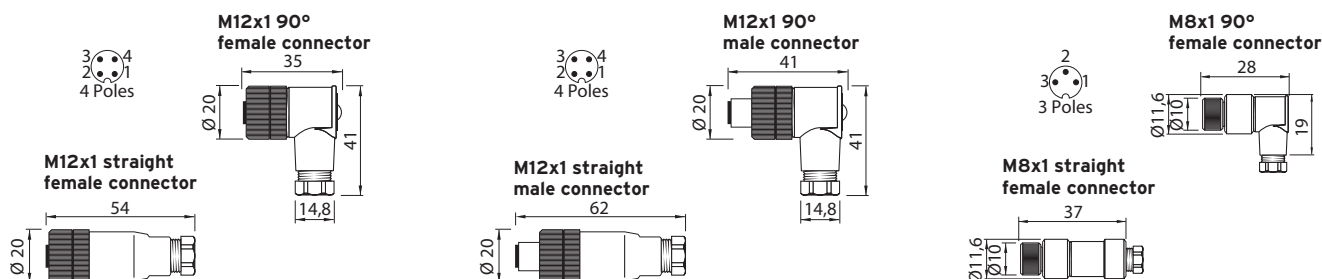

TECHNICAL DATA OF CONNECTORS TO BE WIRED

	M12 4 poles male/female	M8 4 poles female
CONNECTOR POLARITY IN ACCORDANCE WITH IEC 61067-2-101	4 poles	3 and 4 poles
NOMINAL VOLTAGE IN ACCORDANCE WITH DIN VDE 0110 (III/3) AND IEC 60664 -1	125 V dc / 150 V ac (III/3)	60 V dc / 75 V ac (III/3)
NOMINAL VOLTAGE	4 A	4 A
CONTACT RESISTANCE	< 8 m Ω	< 5 m Ω
MASS RESISTIVITY	> 10 ¹² Ω cm	> 10 ¹⁰ Ω cm
TEST VOLTAGE IN ACCORDANCE WITH DIN VDE 0110	1250 V (not connected)	1200 V (not connected)
CONTACTS MATERIAL	CuSnZn	CuZn
CONTACTS SURFACE COVERING MATERIAL	Ni	Au
CONNECTOR MATERIAL	PBT/PA (PBT thermoplastic material - polyester PA polyamide)	PA (polyamide 6.6) - nickel-plated brass
CONNECTOR PLASTIC PARTS COLOUR	Black - RAL 9005	Black - RAL 9005
CONNECTOR USE TEMPERATURE LIMITS	-40° / +85°C	-25° / +90°C
PROTECTION DEGREE IN ACCORDANCE WITH EN 60529 (IEC 60529 AND DIN VDE 0470-1)	IP 67	IP 67
CABLE GLAND	PG 7	-
CABLE GLAND NUT TIGHTENING TORQUE	-	2,5 Nm
MATERIAL OF CONDUCTORS THAT CAN BE WIRED	-	PVC-TPE flexible and semiflexible
SINGLE CONDUCTORS EXTERNAL DIAMETER	-	1,0-1,3 mm (with black moving) 1,3-1,6 mm (with white moving)
EXTERNAL MIN/MAX DIAMETER OF THE CABLE TO BE WIRED	6-8 (mm)	3,0-5,0 (mm)
SECTION TO BE WIRED WITH FLEXIBLE CONDUCTORS	0,25-0,75 mm ² / 24-18 AWG	0,14-0,25 mm ² / AWG 26-24 0,25-0,34 mm ² / AWG 24-22
WIRING NUT FEATURES	20 mm external dia M12x1 threading Nickel-plated brass	10 mm external dia M8x1 threading Nickel-plated brass
COMBUSTIBILITY CLASS ACCORDING TO UL94	HB	V0
CONNECTION	screw	Piercecon - Coninvers GmbH patent

ACCESSORIES

FEMALE AND MALE CONNECTORS

M12

Suitable for:

- 18-MD-FQ-IS-ISM, series (K OUTPUT)
- Connection with distribution boxes (KB series)
- Quick connection sensor - distribution box

KFM Series



M12 4 WIRES IDENTIFICATION CODE

KFM 90 D 060 R

M12 FEMALE AND MALE CONNECTOR

90 FEMALE CONNECTOR

AXIAL FEMALE CONNECTOR

AXIAL MALE CONNECTOR

CABLE LENGTH 60 cm

CABLE LENGTH 150 cm

CABLE LENGTH 300 cm

PREWIRED WITH PUR CABLE OPTIONAL



DIMENSIONS (mm)

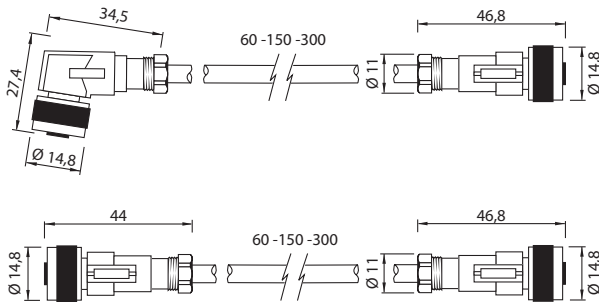

CONTACTS CONFIGURATION

MALE PINS ASSIGNMENT



4 poles

MALE PINS ASSIGNMENT



4 poles

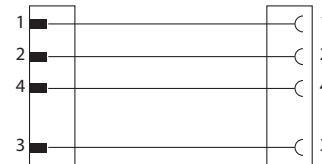

TECHNICAL DATA OF M12 MALE AND FEMALE CONNECTORS

PVC CABLE	
CONNECTOR POLARITY IN ACC. WITH IEC 61067-2 101	3 and 4 wires
NOMINAL VOLTAGE IN ACCORDANCE WITH DIN VDE 0110 (III/3) E IEC 60664 -1	320 V DC / 250 V AC
NOMINAL VOLTAGE	4 A
CONTACT RESISTANCE	< 5 m
TEST VOLTAGE IN ACC. WITH DIN VDE 0110	2,5 KV
CONTACTS MATERIAL	CuSn
CONTACTS SURFACE COVERING MATERIAL	Au
CONNECTOR MATERIAL	inflammable and self extinguish
CONNECTOR COLOUR	Grey - RAL 7035
CONNECTOR USE TEMPERATURE	-25 / +90C
PROTECTION DEGREE IN ACC. WITH EN 60529 (IEC 60529 AND DIN VDE 0470-1)	IP 67
WIRING NUT FEATURES	14,8 mm external dia, M12x1 threading
CABLE TYPE	PVC/PVC
EXTERNAL SLEEVE COLOUR	Grey - RAL 7001
CABLE EXTERNAL DIAMETER	3 and 4 wires = 5,2 mm (0,2 mm)
WIRES SLEEVE MATERIAL	PVC
NO. OF CONDUCTORS ON CABLE SECTION	3 x 0,34 mm ² and 4 x 0,34 mm ²
WIRES COLOUR	in accordance with din DIN 0293
CONDUCTORS STRUCTURE	42 x 0,1 mm in class 6
CABLE BENDING RADIUS	15 times external diameter moving inst. 10 times external diameter steady inst.
TEMPERATURE LIMITS	-30°C / +70°C (steady installation)
ISOLATION VOLTAGE	2500 V; 50 Hz; 5 min.
CABLE MARKS	PVC/PVC UL/CSA
WEIGHT	

ACCESSORIES

The use of this accessory together with a double assigned slots distribution box permits to connect two sensors with a contacts configuration compatible with each available slot.

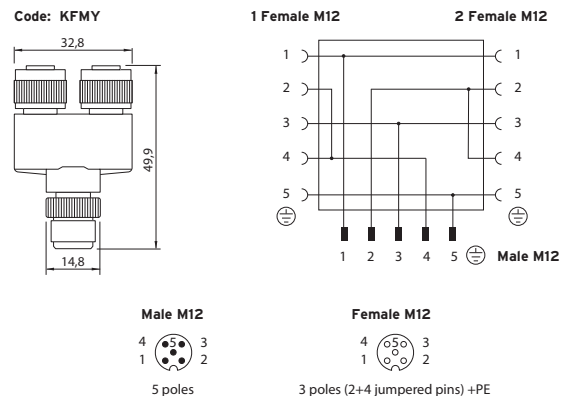

Note: the use of this accessory with a double assigned slots distribution box allows to connect two sensors, having the same and compatible contacts configuration, to each available slot.

ACCESSORIES

M12 DISTRIBUTION BOXES WITH CONNECTED MASTER CABLE

M12 4 WIRES IDENTIFICATION CODE

KB 8 D P C 5

M12 DISTRIBUTION BOXES

8 SLOTS

8

4 SLOTS

4

DOUBLE ASSIGNED SLOTS - OPTIONAL

OPERATION LED (ONLY PNP) - OPTIONAL

CONNECTED MASTER CABLE

CABLE LENGTH 5 m



DIMENSIONS (mm)

Single assigned slot

Double assigned slot

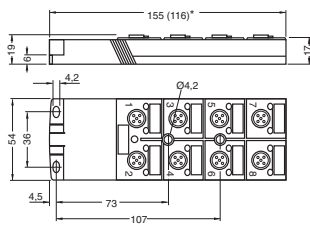
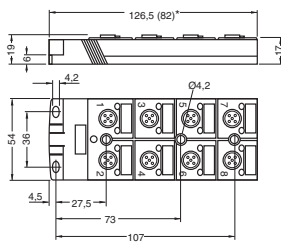

* The dimensions into brackets refer to 4 slot models

WIRING DIAGRAMS FOR SINGLE ASSIGNED SLOT BOXES

Assignment diagram for single assigned slot boxes

Core colour	M12 connector/position (potential)
WH	1 / 4 (A)
GN	2 / 4 (A)
YE	3 / 4 (A)
GY	4 / 4 (A)
PK	5 / 4 (A)
RD	6 / 4 (A)
BK	7 / 4 (A)
VT	8 / 4 (A)
BN	1-8 / (+24 V/120 V)
BU	1-8 / 3 (0 V)
GN / YE	1-8 / 5 (PE)

Circuit diagram for single assigned slot

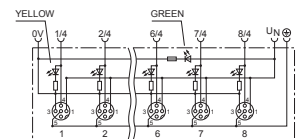

PINS ASSIGNMENT



ACCESSORIES

The use of this accessory together with a double assigned slots distribution box permits to connect two sensors with a contacts configuration compatible with each available slot.

Code: KFMV

1 Female M12

2 Female M12

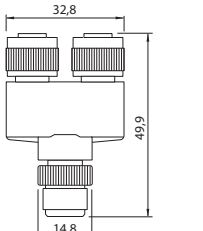

Male M12



5 poles

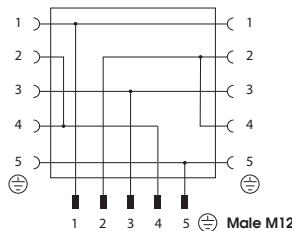

Female M12

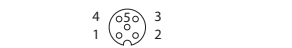

3 poles (2+4 jumpered pins) +PE

Note: the use of this accessory with a double assigned slots distribution box allows to connect two sensors, having the same and compatible contacts configuration, to each available slot.

WIRING DIAGRAMS FOR DOUBLE ASSIGNED SLOT BOXES

Assignment diagram for double assigned slot boxes

Core colour	M12 connector/position (potential)
WH	1 / 4 (A)
GY / PK	1 / 2 (B)
GN	2 / 4 (A)
RD / BU	2 / 2 (B)
YE	3 / 4 (A)
WH / GN	3 / 2 (B)
GY	4 / 4 (A)
BN / GN	4 / 2 (B)
PK	5 / 4 (A)
WH / YE	5 / 2 (B)
RD	6 / 4 (A)
YE / BN	6 / 2 (B)
BK	7 / 4 (A)
WH / GY	7 / 2 (B)
VT	8 / 4 (A)
GY / BN	8 / 2 (B)
BN	1-8 / (+24 V/120 V)
BU	1-8 / 3 (0 V)
GN / YE	1-8 / 5 (PE)

Circuit diagram for double assigned slot

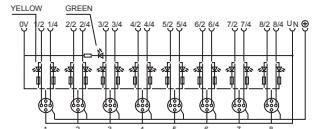

PINS ASSIGNMENT



TECHNICAL DATA

NOMINAL VOLTAGE	120 V AC/120 V DC
MAXIMUM PERMITTED OPERATING VOLTAGE	135 V AC/135 V DC
MAXIMUM CURRENT CARRYING CAPACITY PER CHANNEL	2 A
MAXIMUM CURRENT CARRYING CAPACITY PER SLOT	4 A
SACB TOTAL CURRENT	12 A
AMBIENT TEMPERATURE	-25°C up to +75°C
VIBRATION TEST ACC. DIN EN 60068-2-6:1996-05	
BUMP TEST ACC. DIN EN 60068-2-29:1995-03 (IEC 68-2-297 WITH CONTACT MONITORING ACC. DIN IEC 60512-2:1994-05, TEST 2E	

MATERIAL SPECIFICATIONS

HOUSING MATERIAL (Colour)	Polyamide 66 VO (Grey)
CONTACT SOCKED CARRIER (Colour)	Polyamide 66 VO (Black)
SEALING COMPOUND (Colour)	PUR (Grey)
CONTACT MATERIAL SPECIFICATION	
- LIVE PARTS	Copper alloy
- SURFACE PLATING	Gold plated

ACCESSORIES

M12 DISTRIBUTION BOXES TO BE WIRED CONNECTION VIA SPRING CAGE TERMINAL BLOCKS

KB Series



M12 4 WIRES IDENTIFICATION CODE

KB 8 D P

M12 DISTRIBUTION BOXES

8 SLOTS **8**

4 SLOTS **4**

DOUBLE ASSIGNED SLOTS - OPTIONAL

OPERATION LED (ONLY PNP) - OPTIONAL



DIMENSIONS (mm)

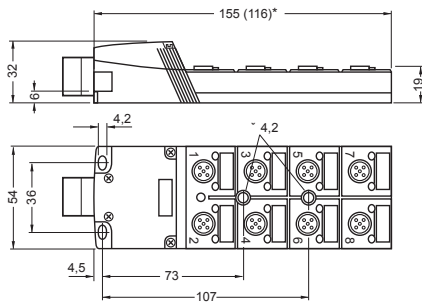

* The dimensions into brackets refer to 4 slot models

WIRING DIAGRAMS FOR SINGLE ASSIGNED SLOT BOXES

Assignment diagram for single assigned slot boxes

Terminal point M12 connector/position (potential)	
1 / 4	1 / 4 (A)
2 / 4	2 / 4 (A)
3 / 4	3 / 4 (A)
4 / 4	4 / 4 (A)
5 / 4	5 / 4 (A)
6 / 4	6 / 4 (A)
7 / 4	7 / 4 (A)
8 / 4	8 / 4 (A)
U _N	1-8 / (+24 V/120 V)
PE	1-8 / 5 (PE)
0 V	1-8 / 3 (0 V)

Circuit diagram for single assigned slot

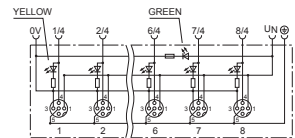

PINS ASSIGNMENT



ACCESSORIES

The use of this accessory together with a double assigned slots distribution box permits to connect two sensors with a contacts configuration compatible with each available slot.

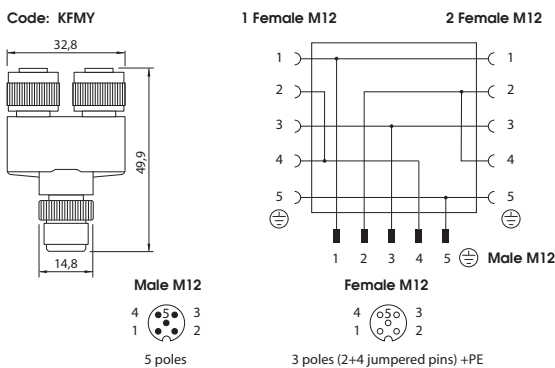

Note: the use of this accessory with a double assigned slots distribution box allows to connect two sensors, having the same and compatible contacts configuration, to each available slot.

WIRING DIAGRAMS FOR DOUBLE ASSIGNED SLOT BOXES

Assignment diagram for double assigned slot boxes

Terminal point M12 connector/position (potential)	
1 / 4	1 / 4 (A)
1 / 2	1 / 2 (B)
2 / 4	2 / 4 (A)
2 / 2	2 / 2 (B)
3 / 4	3 / 4 (A)
3 / 2	3 / 2 (B)
4 / 4	4 / 4 (A)
4 / 2	4 / 2 (B)
5 / 4	5 / 4 (A)
5 / 2	5 / 2 (B)
6 / 4	6 / 4 (A)
6 / 2	6 / 2 (B)
7 / 4	7 / 4 (A)
7 / 2	7 / 2 (B)
8 / 4	8 / 4 (A)
8 / 2	8 / 2 (B)
U _N	1-8 / (+24 V/120 V)
PE	1-8 / 5 (PE)
0 V	1-8 / 3 (0 V)

Circuit diagram for double assigned slot

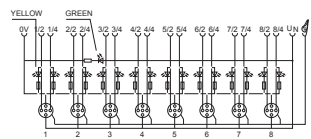

PINS ASSIGNMENT



TECHNICAL DATA

NOMINAL VOLTAGE	24 V DC
MAXIMUM PERMITTED OPERATING VOLTAGE	30 V DC
MAXIMUM CURRENT CARRYING CAPACITY PER CHANNEL	2 A
MAXIMUM CURRENT CARRYING CAPACITY PER SLOT	4 A
SACB TOTAL CURRENT	12 A
AMBIENT TEMPERATURE	-25°C up to +75°C
VIBRATION TEST ACC. DIN EN 60068-2-6:1996-05	
BUMP TEST ACC. DIN EN 60068-2-29:1995-03 (IEC 68-2-297 WITH CONTACT MONITORING ACC.	
DIN IEC 60512-2:1994-05, TEST 2E	
IP 65/67 PROTECTION TYPE TEST ACC. DIN EN 60529/VDE 0470 TEIL 1:2000-09	

MATERIAL SPECIFICATIONS

HOUSING MATERIAL (Colour)	Polyamide 66 VO (Grey)
CONTACT SOCKED CARRIER (Colour)	Polyamide 66 VO (Black)
SEALING COMPOUND (Colour)	PUR (Grey)
CONTACT MATERIAL SPECIFICATION	
- LIVE PARTS	Copper alloy
- SURFACE PLATING	Gold plated