



## System Components for Automation

Catalog

12

[www.helmholz.com](http://www.helmholz.com)

**How to contact us:**

Orders by phone: +49 9135 7380-0

Orders by fax: +49 9135 7380-490

Orders by email: [orders@helmholz.de](mailto:orders@helmholz.de)

**In the Internet:**

Homepage: <http://www.helmholz.com>

E-Mail: [info@helmholz.de](mailto:info@helmholz.de)



	Page
Components for S7	7–37
PROFIBUS	38–64
NETLink® Gateways	65–76
Teleservice	77–88
CAN Bus	89–98
Interface Converter	99–106
Components for S5	107–121
Service	122–127

**Systeme Helmholtz**®, **EasyConnect**®, **FLEXtra**® and **NETLink**® are registered trademarks of Systeme Helmholtz GmbH.  
 S7-200, S7-300, S7-400, WinCC, ProTool, Simatic and STEP are registered trademarks of Siemens AG.  
 All companies and product names mentioned are only used for identification purposes and are/can be registered trademarks of the respective brand owner.

Our General Terms and Conditions of business are applicable.  
 For all information in this catalogue, particularly for the stated technical values, dimensions and weights, we reserve the right to make changes and accept no responsibility for errors and omissions. Illustrations can be different from the original.  
 Date November 2010

## Contents

## Components for S7

## Memory for S7

Micro Memory Cards .....	8
Memory Cards .....	9

## Input/Output Modules for S7

DEA 300, Digital Input Modules .....	10
DEA 300, Digital Input Module, m-reading .....	12
DEA 300, Digital Input Module with Alerts .....	13
DEA 300, Digital Output Modules .....	14
DEA 300, Digital Input/Output Modules .....	16
DEA 300, Digital Output Module; 2 Amps .....	18
DEA 300, Digital Output Convert; Relays .....	19
DEA 300, Digital Input Modules; 120/230 V .....	21
AEA 300, Analog Input Module for Connecting Sensors with Current Signals .....	22
AEA 300, Analog Input Module for Connecting Sensors with Voltage Signals .....	23
AEA 300, Analog Input Module for Connecting Resistance Thermometers .....	24
AEA 300, Analog Input Module; Current Signals, Voltage Signals, Resistance, Resistance Thermometer .....	25
AEA 300, Analog Output Module; 4-Channel .....	26
AEA 300, Analog Output Modules; 2-Channel .....	27
Dummymodule .....	28
PAS 153, distributed PROFIBUS Interface .....	29

## Communication Modules

SAS 340, Communication Module .....	30
SAS 341, Communication Module .....	31
EIB 300, Communication Module for Twisted Pair EIB/KNX .....	32

## Front Connectors for S7

<b>FastPlug</b> , Frontadapter for S7 modules .....	34
Front Connectors with screw contacts, Front Connectors <b>EasyConnect</b> ® .....	35
Front Connectors with spring contacts, Ready-wired Front Connectors .....	36

## Accessory

Mounting rail, Mounting rail adapter for DIN rail .....	37
---	----

## PROFIBUS

## PROFIBUS Connectors

PROFIBUS Connector, 90° .....	39
PROFIBUS Connector, 35° .....	40
PROFIBUS Connector, axial .....	41
PROFIBUS Connector, 90° <b>EasyConnect</b> ® .....	42
PROFIBUS Connector, angled <b>EasyConnect</b> ® .....	43
PROFIBUS Connector, axial <b>EasyConnect</b> ® .....	44
PROFIBUS Connector, 90° with diagnostic LEDs, <b>EasyConnect</b> ® .....	45
PROFIBUS Connector, 90° with diagnostic LEDs .....	46
PROFIBUS Connector with ATEX accreditation .....	47
PROFIBUS Connector with spring type terminals .....	48
PROFIBUS Connector, 90° M12 .....	49

## PROFIBUS Repeater

FLEXtra® twinRepeater, PROFIBUS Repeater .....	50
FLEXtra® multiRepeater 4-way/6-way, PROFIBUS Repeater .....	52
PROFIBUS Compact Repeater .....	54

**PROFIBUS Radio System**

viBlu, PROFIBUS Radio System .....	56
PAS 153 viBlu, distributed PROFIBUS Radio Interface .....	58
Antennas for NETLink® WLAN and viBlu .....	60
<b>PROFIBUS Communication</b>	
PAS 153, distributed PROFIBUS Interface .....	61
DP/DP Coupler .....	62
<b>PROFIBUS Accessory</b>	
FLEXtra® profiPoint, active Termination and Measuring Point .....	63
Active PROFIBUS Dropcable .....	64

**NETLink® Gateways****Ethernet**

NETLink® PRO Compact, PROFIBUS-Ethernet Gateway .....	66
NETLink® PRO, Ethernet Gateway for MPI/PROFIBUS .....	68
NETLink® Switch, Ethernet Gateway with integrated 4-port Switch .....	69

**WLAN**

NETLink® WLAN, PROFIBUS Ethernet WLAN Gateway .....	70
Antennas for NETLink® WLAN and viBlu .....	71

**NETLink® PRO Family applications**

NETLink® PRO Family applications .....	72
--	----

**USB**

NETLink® USB Compact, mini PROFIBUS USB Gateway .....	73
NETLink® USB, Highspeed USB Gateway for MPI/PROFIBUS .....	74
NETLink® SLOT USB, Highspeed USB Gateway as a plug-in board .....	75

**OPC**

OPC-Server .....	76
------------------	----

**Teleservice****Router**

REX 300, Ethernet Router .....	78
--------------------------------	----

**SSW7/TS 300**

SSW7-TS, MPI Adapter .....	81
SSW7-TS with Modem; analog/ISDN/GSM .....	82
SSW7-TS PRO analog/ISDN/GSM .....	83
TS 300, Teleservicemodule for the PLC Rack .....	84

**Modem**

MDM 300, Modem for the S7 Rack .....	86
--------------------------------------	----

**Antennas**

Antennas for GSM Modems .....	88
-------------------------------	----

**CAN Bus****Communication Modules**

CAN 300 PRO, Communication Module .....	90
CAN 300, Communication Module with DNV certificate .....	92
CAN 400, Communication Module .....	93

**Coupler**

DP/CAN Coupler CANopen® .....	94
DP/CAN Coupler Layer 2 .....	95

**Software**

CAN Software .....	96
--------------------	----

## Contents

### Accessory/Connectors

CAN Bus Connector .....	97
-------------------------	----

### CAN Bridge

CAN Bridge, connecting CAN networks .....	98
---	----

## Interface Converters

### Fibre Optic Converter

OPTopus, PROFIBUS Optical Link .....	100
--------------------------------------	-----

### MPI-Bus

SSW7, MPI-Programming Adapter .....	102
-------------------------------------	-----

SSW7-USB, MPI-Programming Adapter USB .....	103
---	-----

SSW7-RK512, SSW7-HMI, MPI-Adapter with RK512/HMI Protocol .....	104
---	-----

Multiplexer for MPI and PROFIBUS .....	106
--	-----

## Components for S5

### Interface Converters

SSW5/LAN, S5 Ethernet Converter .....	108
---------------------------------------	-----

SSW5/USB, Programming Cable .....	109
-----------------------------------	-----

SSW3, RS232-TTY Converter Cable .....	110
---------------------------------------	-----

SSW4, RS232-TTY Converter Cable .....	111
---------------------------------------	-----

### Memory Submodules for S5

Memory Cards .....	112
--------------------	-----

RAM Submodules .....	113
----------------------	-----

EPROM, EEPROM .....	114
---------------------	-----

### Input/Output Modules for S5

DEA 115, Digital Input/Output Modules .....	115
---	-----

DEA 115, Digital Input/Output Modules .....	116
---	-----

DEA 135, Digital Input/Output Modules .....	117
---	-----

DEA 135, Digital Input/Output Modules .....	118
---	-----

AEA 115, Analog Input Modules .....	119
-------------------------------------	-----

AEA 115, Analog Output Modules .....	120
--------------------------------------	-----

### Communication for S5

SAS 523/525, Serial Interface Modules .....	121
---	-----

## Service

Customer-Specific Development .....	123
-------------------------------------	-----

Training Courses, PROFIBUS Service .....	124
--	-----

Fax Order Form .....	125
----------------------	-----

Contacts in Germany .....	126
---------------------------	-----

International Contacts .....	127
------------------------------	-----



# Components for S7

Micro Memory Cards  
Memory Cards  
Digital Modules  
Analog Modules  
Front Connectors

## Micro Memory Cards



Micro Memory Cards



The Micro Memory Cards from the Systeme Helmholtz GmbH are suitable for use in S7 controllers.

Our product program includes a whole range of the most commonly required modules. The Micro Memory Cards are available with the following memory capacities:

64 kB, 128 kB, 256 kB, 512 kB, 1 MB, 2 MB, 4 MB, 8 MB.

We are able to offer you a very advantageous price-performance ratio due to our modern production methods.

Ordering Data	
	Order No.
<b>Micro Memory Cards</b>	
64 kByte	700-953-8LF11
128 kByte	700-953-8LG11
256 kByte	700-953-8LH11
512 kByte	700-953-8LJ11
1 MByte	700-953-8LK11
2 MByte	700-953-8LL11
4 MByte	700-953-8LM11
8 MByte	700-953-8LP11

Technical Data	
Micro Memory Cards	
Memory capacity	64 kByte 128 kByte 256 kByte 512 kByte 1 MByte 2 MByte 4 MByte 8 MByte
Applications	CPU 312C CPU 313C CPU 314C CPU 312 ... 317, new type IM 151, IM 153, IM 154 CPU C7



## Memory Cards



Memory Card, long type



Memory Cards from the Systeme Helmholtz GmbH are designed for use in CPU modules CPU 412 to CPU 417.

We have been able to achieve top quality standards and a very advantageous price-performance ratio with the use of modern manufacturing methods.

Our product program covers the range of the most common submodules.

Ordering Data	
	Order No.
<b>Flash EPROM Cards, long</b>	
64 kByte	700-952-0KF00
256 kByte	700-952-0KH00
1 MByte	700-952-1KK00
2 MByte	700-952-1KL00
4 MByte	700-952-1KM00
8 MByte	700-952-1KP00
16 MByte	700-952-1KS00
<b>RAM Cards, long</b>	
64 kByte	700-952-0AF00
256 kByte	700-952-1AH00
1 MByte	700-952-1AK00
2 MByte	700-952-1AL00
4 MByte	700-952-1AM00
8 MByte	700-952-1AP00

Technical Data	
<b>Flash EPROM Cards, long</b> Memory capacity	64 kByte, 256 kByte, 1 MByte, 2 MByte, 4 MByte, 8 MByte, 16 MByte
Applications	CPU 412 to 417
<b>RAM Cards, long</b> Memory capacity	64 kByte, 256 kByte, 1 MByte, 2 MByte, 4 MByte, 8 MByte
Applications	CPU 412 to 417

## DEA 300, Digital Input Modules



Digital input modules with 16 and 32 inputs

The digital inputs convert the external binary signals from the process into the internal signal level of the programmable controller.

Green LEDs indicate the signal state of the inputs and outputs. The inputs of the modules from the Systeme Helmholtz GmbH are also suitable for connection of 2-wire proximity switches. Modules with modified specifications or special modules can be supplied on request.

**Accessory-Note**

The Systeme Helmholtz GmbH supplies front connectors and cable sets (see page 34–36).



Open type Programmable Controllers, for use in Hazardous Locations, Class I, Div. 2 Groups A, B, C, D T4 including Class I Zone 2 IIC.

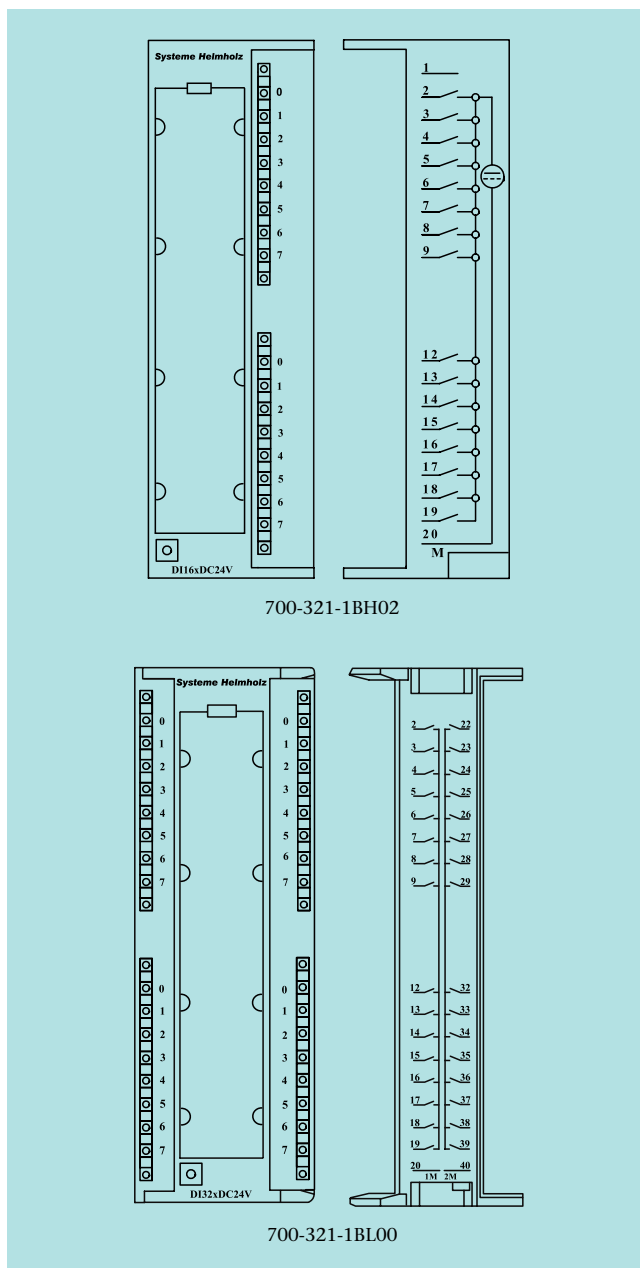

700-321-1BH02

700-321-1BL00

**Ordering Data**

	Order No.
DEA 300 16snubb (DC 24 V) 32 inputs (DC 24 V)	700-321-1BH02 700-321-1BL00
Manual DEA 300, German/English	900-321-1DE11

## DEA 300, Digital Input Modules

Technical Data			700-321-1BH02	700-321-1BL00
<b>Number of inputs</b>			16	32
Isolation (from backplane bus) In groups of			Yes (optocoupler) 16	Yes (optocoupler) 16
<b>Input voltage</b> • nom. value • for "0" signal • for "1" signal			DC 24 V -3 ... +5 V +13 ... +30 V	DC 24 V -3 ... +5 V +13 ... +30 V
<b>Input current</b> • for "1" signal	typ.		7 mA	7 mA
Delay time	typ.		1.2 ... 4.8 ms	1.2 ... 4.8 ms
Connection of 2-wire initiator Perm. quiescent current for "0" signal	max.		Yes 1.5 mA	Yes 1.5 mA
<b>Cable length</b> • unshielded • shielded	max. max.		600 m 1000 m	600 m 1000 m
<b>Current consumption</b> • internal (backplane bus) • external (from +24 V)	typ. max.		20 mA 140 mA	30 mA 290 mA
Power loss (rated operation)	typ.		3.5 W	6.8 W
Front connector			20-way	40-way
Ambient temperature Transport and storage temperature			0 °C ... 60 °C -25 °C ... 75 °C	0 °C ... 60 °C -25 °C ... 75 °C

## DEA 300, Digital Input Module, m-reading



DEA 300, m-reading

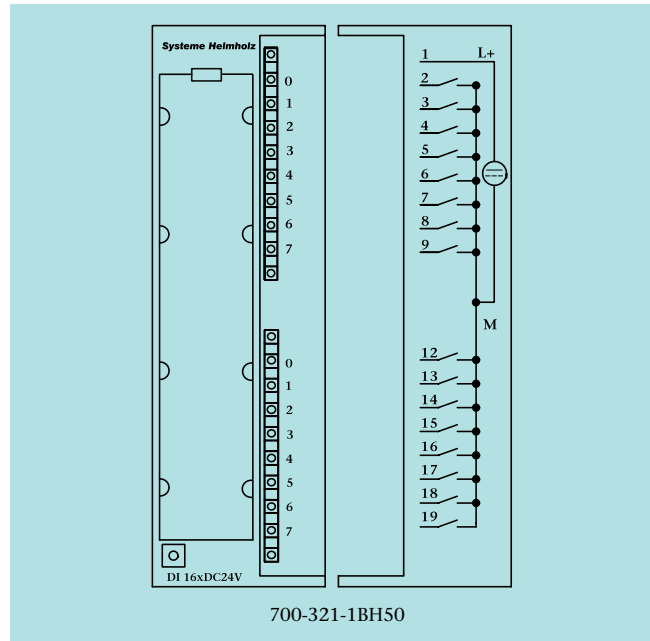

The digital inputs convert the external binary signals from the process into the internal signal level of the programmable controller.

Green LEDs indicate the signal state of the inputs and outputs. The inputs of the modules from the Systeme Helmholtz GmbH are also suitable for connection of 2-wire proximity switches. Modules with modified specifications or special modules can be supplied on request.

**Accessory-Note**

The Systeme Helmholtz GmbH supplies front connectors and cable sets (see page 34–36).

Ordering Data	
	Order No.
DEA 300 16 inputs, m-reading	700-321-1BH50
Manual DEA 300, German/English	900-321-1DE11

Technical Data	
Number of inputs	16
Isolation against backplane bus In groups of	Yes (optocoupler) 16
Input voltage, reference potential is L+ <ul style="list-style-type: none"> <li>• nom. value</li> <li>• for Signal "0"</li> <li>• for Signal "1"</li> </ul>	DC 24 V +30 ... -5 V -13 ... -30 V
Input current <ul style="list-style-type: none"> <li>• for Signal "1"</li> </ul>	7 mA
Delay time	1.2 ... 4.8 ms
Cable length <ul style="list-style-type: none"> <li>• unshielded</li> <li>• shielded</li> </ul>	600 m 1000 m
Current consumption <ul style="list-style-type: none"> <li>• internal (backplane bus)</li> </ul>	10 mA
Power loss (nominal operation)	3.5 W
Front connector	20-way
Ambient temperature Transport and storage temperature	0 °C ... 60 °C -25 °C ... 75 °C

## DEA 300, Digital Input Module with Alerts



DEA 300, with Alerts

The digital inputs convert the external binary signals from the process into the internal signal level of the programmable controller.

Green LEDs indicate the signal state of the inputs and outputs. The inputs of the modules from the Systeme Helmholz GmbH are also suitable for connection of 2-wire proximity switches.

This module offers as additional features parameterizable diagnostics, diagnostic- and processalerts, as well as a parameterizable input delay.

Modules with modified specifications or special modules can be supplied on request.

**Accessory-Note**

The Systeme Helmholz GmbH supplies front connectors and cable sets (see page 34–36).

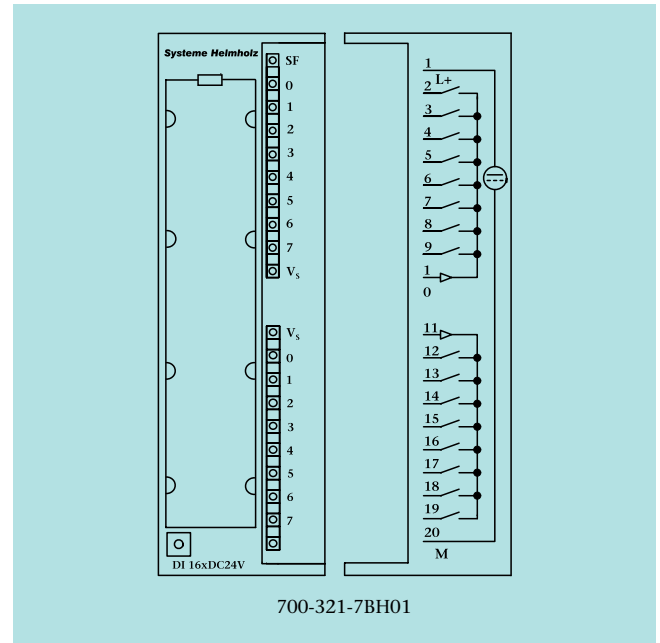

700-321-7BH01

**Features**

- Parameterizable diagnostics
- Diagnostic- and processalerts
- Parameterizable input delay

**Technical Data**

<b>Number of inputs</b>	<b>16</b>
Isolation against backplane bus In groups of	Yes (optocoupler) 16
<b>Input voltage, reference potential is L+</b>	
• nom. value	DC 24 V
• for Signal "0"	-30 ... +5 V
• for Signal "1"	+13 ... +30 V
<b>Input current</b>	
• for Signal "1"	7 mA
Delay time parameterizable	Yes (0.1; 0.5; 3; 15; 20 ms)
Diagnostics	Parameterizable
Process alerts	Parameterizable
Diagnostic alerts	Parameterizable
<b>Conduction length</b>	
• unshielded	600 m
• shielded	1000 m
<b>Current consumption</b>	
• internal (backplane bus) typ.	130 mA
• extern L+, DC 24 V	90 mA
<b>Encoder power supply outputs</b>	
Output voltage	min L+ DC -2.5 V
Output current	0 ... 150 mA
Short-circuit protection	Electrical
Power loss (nominal operation)	4 W
Front connector	20-way
Ambient temperature	0 °C ... 60 °C
Transport and storage temperature	-25 °C ... 75 °C

**Ordering Data**

	Order No.
<b>DEA 300</b> 16 inputs, with Alerts	<b>700-321-7BH01</b>
<b>Manual DEA 300, German/English</b>	<b>900-321-1DE11</b>

## DEA 300, Digital Output Modules



Digital output modules with 16 and 32 outputs

The digital outputs convert the internal signal level to the external signal level required for the process. Green LEDs indicate the signal state of the outputs.

The outputs of the modules from the Systeme Helmholz GmbH are also suitable for connection of, for example, solenoid valves, contactors, and small-power motors within the permissible data. Modules with modified specifications or special modules can be supplied on request.

**Accessory-Note**

The Systeme Helmholz GmbH supplies front connectors and cable sets (see page 34–36).

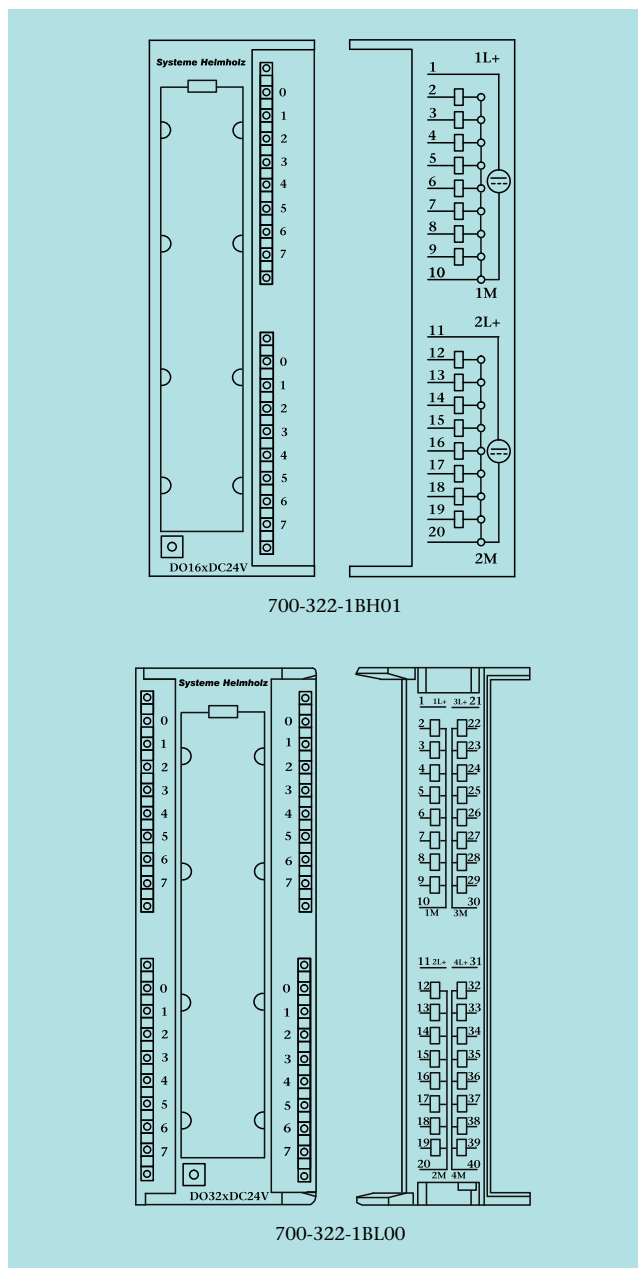

Open type Programmable Controllers, for use in Hazardous Locations, Class I, Div. 2 Groups A, B, C, D T4 including Class I Zone 2 IIC.

**Ordering Data**

	Order No.
<b>DEA 300</b>	
16 outputs (DC 24 V; 0,5 A)	700-322-1BH01
32 outputs (DC 24 V; 0,5 A)	700-322-1BL00
<b>Manual DEA 300, German/English</b>	900-321-1DE11

## DEA 300, Digital Output Modules

Technical Data		
	700-322-1BH01	700-322-1BL00
<b>Number of outputs</b>	<b>16</b>	<b>32</b>
Isolation against backplane bus In groups of	Yes (optocoupler) 8	Yes (optocoupler) 8
<b>Supply voltage <math>V_p, V_s</math></b> • nom. value • ripple $V_{pp}$ max. • permissible range (with ripple) • value at $t < 10$ ms max.	DC 24 V 3.6 V 20 ... 30 V 50 V	DC 24 V 3.6 V 20 ... 30 V 50 V
<b>Output current</b> • nom. value	0.5 A	0.5 A
Short-circuit protection	Electrical	Electrical
Voltage induced on circuit interruption limited to	-48 V	-48 V
<b>Cable length</b> • unshielded max. • shielded max.	600 m 1000 m	600 m 1000 m
<b>Current consumption</b> • internal (backplane bus) max. • ext. w/o load (from +24 V) typ.	100 mA 120 mA	125 mA 200 mA
Power loss (nominal operation) typ.	5 W	6.8 W
Front connector	20-way	40-way
Ambient temperature Transport and storage temperature	0 °C ... 60 °C -25 °C ... 75 °C	0 °C ... 60 °C -25 °C ... 75 °C

## DEA 300, Digital Input/Output Modules



Digital input/output modules

The digital inputs convert the external binary signals from the process into the internal signal level of the programmable controller.

The digital outputs convert the internal signal level of the programmable controllers into the external binary signal level required for the process. Green LEDs indicate the signal state of the inputs and outputs.

The inputs of the modules from the Systeme Helmholz GmbH are also suitable for connection of 2-wire proximity switches, the outputs for connection of, for example, solenoid valves, contactors, and small motors within the permissible data.

Modules with modified specifications or special modules can be supplied on request.

**Accessory-Note**

The Systeme Helmholz GmbH supplies front connectors and cable sets (see page 34–36).



Open type Programmable Controllers, for use in Hazardous Locations, Class I, Div. 2 Groups A, B, C, D T4 including Class I Zone 2 IIC.

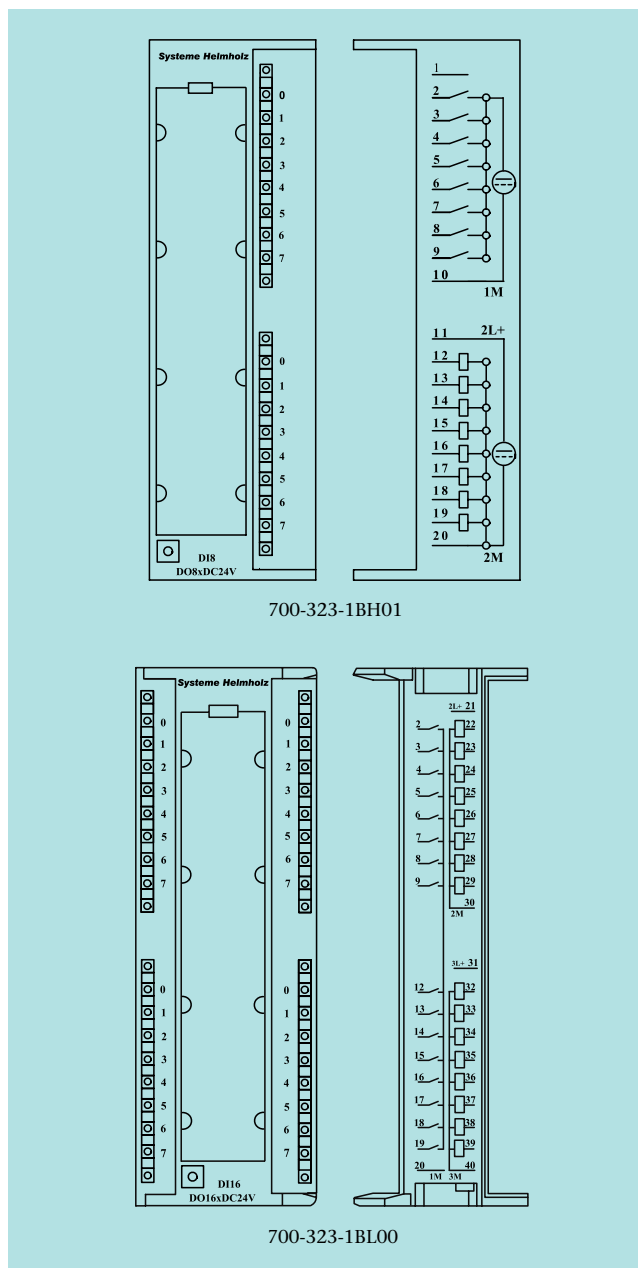

700-323-1BH01

700-323-1BL00

**Ordering Data**

	Order No.
<b>DEA 300</b>	
8 inputs (DC 24 V)/ 8 outputs (DC 24 V; 0,5 A)	700-323-1BH01
16 inputs (DC 24 V)/ 16 outputs (DC 24 V; 0,5 A)	700-323-1BL00
<b>Manual DEA 300, German/English</b>	900-321-1DE11



## DEA 300, Digital Input/Output Modules

Technical Data		
	700-323-1BH01	700-323-1BL00
<b>Number of inputs</b>	<b>8</b>	<b>16</b>
Isolation (from backplane bus) In groups of	Yes (optocoupler) 8	Yes (optocoupler) 16
<b>Input voltage</b> • nom. value • for Signal "0" • for Signal "1"	DC 24 V -3 ... +5 V +13 ... +30 V	DC 24 V -3 ... +5 V +13 ... +30 V
<b>Input current</b> • for "1" signal	typ. 7 mA	7 mA
Delay time	typ. 1.2 ... 4.8 ms	1.2 ... 4.8 ms
Connection of 2-wire initiator Perm. quiescent current for "0" signal	Yes max. 1.5 mA	Yes 1.5 mA
<b>Cable length</b> • unshielded • shielded	max. 600 m max. 1000 m	600 m 1000 m
<b>Number of outputs</b>	<b>8</b>	<b>16</b>
Isolation (from backplane bus) in groups of	Yes (optocoupler) 8	Yes (optocoupler) 8
<b>Output current</b> • nom. value	0.5 A	0.5 A
Short-circuit protection	Electronic	Electronic
Voltage induced on circuit interruption limited to	- 48 V	- 48 V
<b>Cable length</b> • unshielded • shielded	max. 600 m max. 1000 m	600 m 1000 m
<b>Supply voltage <math>V_p</math>, <math>V_s</math></b> • nom. value • ripple $V_{pp}$ • permissible range (with ripple) • value at $t < 10$ ms	max. DC 24 V 3.6 V 20 ... 30 V max. 50 V	DC 24 V 3.6 V 20 ... 30 V 50 V
<b>Current consumption</b> • internal (backplane bus) • external (without load, from +24 V)	max. 55 mA typ. 60 mA	90 mA 120 mA
Power loss (nominal operation)	typ. 3.5 W	6.8 W
Front connector	20-way	40-way
Ambient temperature Transport and storage temperature	0 °C ... 60 °C -25 °C ... 75 °C	0 °C ... 60 °C -25 °C ... 75 °C

## DEA 300, Digital Output Module; 2 Amps



Digital output module; 8 outputs, 2 amps

The digital outputs convert the internal signal level to the external signal level required for the process. Green LEDs indicate the signal state of the outputs.

The outputs of the modules from the Systeme Helmholtz GmbH are also suitable for connection of, for example, solenoid valves, contactors, and small-power motors within the permissible data. The output power of 2 amps per channel is also suitable for larger loads.

**Accessory-Note**

The Systeme Helmholtz GmbH supplies front connectors and cable sets (see page 34–36).



Open type Programmable Controllers, for use in Hazardous Locations, Class I, Div. 2 Groups A, B, C, D T4 including Class I Zone 2 IIC.

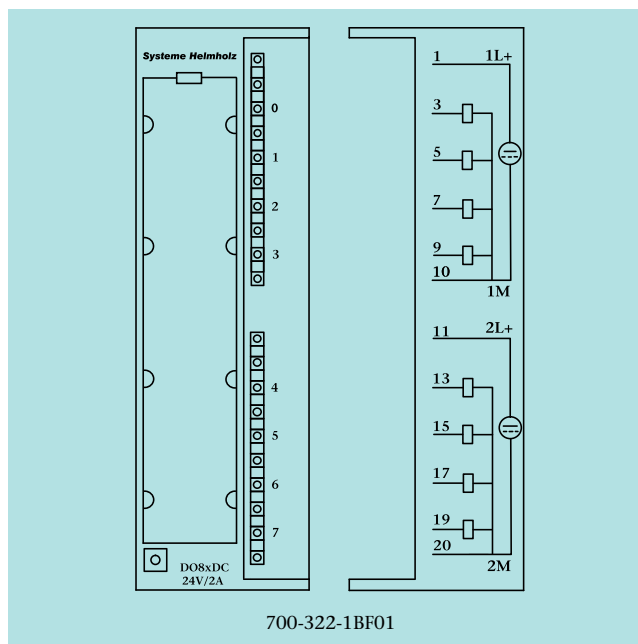

700-322-1BF01

Technical Data	
<b>Number of outputs</b>	<b>8</b>
Isolation (from backplane bus) In groups of	Yes (optocoupler) 4
<b>Supply voltage <math>V_p, V_s</math></b>	
• nom. value	DC 24 V
• ripple $V_{pp}$ max.	3.6 V
• permissible range (with ripple)	20 ... 30 V
• value at $t < 10$ ms max.	40 V
<b>Output current</b>	
• nom. value	2 A
<b>Aggregate current of the outputs (per group, horizontal mounting)</b>	
• to 40 °C	8 A
• to 55 °C	6 A
Short-circuit protection	Electronic
Short-circuit current typ.	12 A clocked
Voltage induced on circuit interruption limited to	- 23 V
<b>Cable length</b>	
• unshielded max.	600 m
• shielded max.	1000 m
<b>Current consumption</b>	
• internal (backplane bus) max.	40 mA
• ext.(without load, from +24 V) typ.	60 mA
Power loss (nominal operation) typ.	6.8 W
Front connector	20-way
Ambient temperature	0 °C ... 60 °C
Transport and storage temperature	-25 °C ... 75 °C

Ordering Data	
	Order No.
<b>DEA 300</b> 8 outputs (DC 24 V; 2 A)	<b>700-322-1BF01</b>
<b>Manual DEA 300, German/English</b>	<b>900-321-1DE11</b>

## DEA 300, Digital Output Convert; Relays



Digital output convert; 8 relays

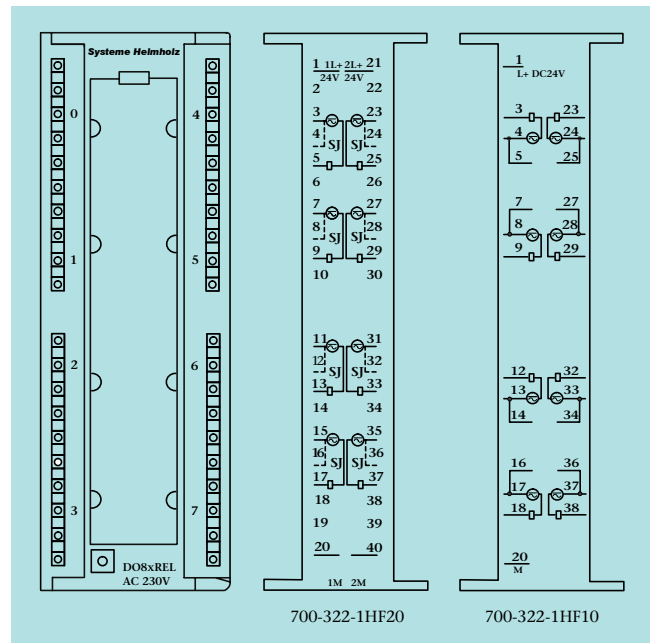

The digital outputs convert the internal signal level into the external signal levels required for the process.

Green LEDs indicate the signal state of the outputs.

The outputs of the modules from the Systeme Helmholtz GmbH are suitable for connection of solenoid valves, contactors, and small-power motors within the permissible range, etc. The output power of up to 5 amps per group is also suitable for larger loads.

**Accessory-Note**

The Systeme Helmholtz GmbH supplies front connectors and cable sets (see page 34–36).



Open type Programmable Controllers, for use in Hazardous Locations, Class I, Div. 2 Groups A, B, C, D T4 including Class I Zone 2 IIC.

**Technical Data**

<b>Number of outputs</b>	<b>8</b>
Nom. load voltage L+/L-	DC 24 V
Switching voltage	AC to 230 V DC to 120 V
<b>Output current</b> Aggregate current of the output (per group)	max. 5 A
<b>Isolation to</b> • backplane bus • in groups	Optocoupler 1
<b>Switching frequency</b> • resistive load • inductive load • lamp load • mechanical	max. 2 Hz max. 0.5 Hz max. 2 Hz max. 10 Hz
<b>Rated load</b> • resistive load • inductive load	max. 8 A (AC 230 V) 8 A (DC 24 V) max. 3 A (AC 230 V) 2 A (DC 24 V)
<b>Expected life</b> • mechanical • resistive load	10 Mio. 5 A, 0.2 Mio.
Ambient temperature Transport and storage temperature	0 °C ... 60 °C -25 °C ... 75 °C

**Ordering Data**

	Order No.
<b>DEA 300</b> 8 outputs, relays, 5 A 8 outputs, relays, 5 A, snubber	<b>700-322-1HF10</b> <b>700-322-1HF20</b>
<b>Manual DEA 300, German/English</b>	<b>900-321-1DE11</b>

## DEA 300, Digital Output Convert; Relays



Digital output convert, 16 relays

The digital outputs convert the internal signal level into the external signal levels required for the process. Green LEDs indicate the signal state of the outputs. The outputs of the modules from the Systeme Helmholtz GmbH are suitable for connection of solenoid valves, contactors, and small-power motors within the permissible range, etc. The output power of up to 8 amps per group is also suitable for larger loads.

**Accessory-Note**

The Systeme Helmholtz GmbH supplies front connectors and cable sets (see page 34–36).



**Order No. 700-322-1HH01:**  
Open type Programmable Controllers, for use in Hazardous Locations, Class I, Div. 2 Groups A, B, C, D T6 including Class I Zone 2, IIC.

Technical Data		
	700-322-1HH01	700-322-1HF01
<b>Number of outputs</b>	16	8
Nom. load voltage L+/L-	DC 24 V	DC 24 V
Switching voltage	AC to 230 V DC to 120 V	AC to 230 V DC to 120 V
<b>Output current</b> Aggregate current of the output (per group) max.	8 A	4 A
Isolation to backplane bus • in groups	Optocoupler 8	Optocoupler 2
Continuous thermal current	2 A	3 A
<b>Switching frequency</b> • resistive load max. • inductive load max. • lamp load max. • mechanical max.	1 Hz 0,5 Hz 1 Hz 10 Hz	2 Hz 0,5 Hz 2 Hz 10 Hz
<b>Rated load</b> • resistive load max. • inductive load max.	2 A (AC 230 V) 2 A (DC 24 V) 2 A (AC 120 V) 2 A (DC 24 V)	2 A (AC 230 V) 2 A (DC 24 V) 2 A (AC 120 V) 2 A (DC 24 V)
<b>Expected life</b> • mechanical • resistive load	10 Mio. 2 A, 1 Mio.	10 Mio. 2 A, 0,7 Mio.
Ambient temperature Transport and storage temperature	0 °C ... 60 °C -25 °C ... 75 °C	0 °C ... 60 °C -25 °C ... 75 °C

**Ordering Data**

	Order No.
<b>DEA 300</b> 16 outputs, relays, 2 A 8 outputs, relays, 2 A	<b>700-322-1HH01</b> <b>700-322-1HF01</b>
<b>Manual DEA 300, German/English</b>	<b>900-321-1DE11</b>

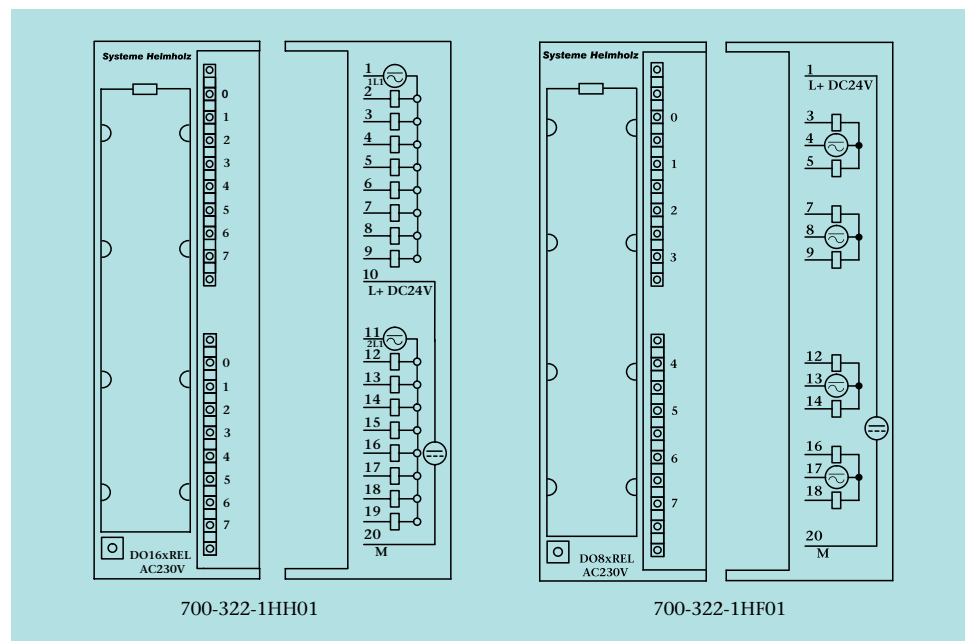

DEA 300, Digital Input Modules; 120/230 V



Digital input convert, 120/230 V

The digital inputs convert the external binary signals from the process into the internal signal level of the programmable controller.

Green LEDs indicate the signal state of the inputs and outputs. The inputs of the modules from the Systeme Helmholtz GmbH are also suitable for connection of 2-wire proximity switches. This module offers as additional features parameterizable diagnostic- and processalerts, as well as a parameterizable input delay. Modules with modified specifications or special modules can be supplied on request.

**Accessory-Note**

The Systeme Helmholtz GmbH supplies front connectors and cable sets (see page 34-36).



Open type Programmable Controllers, for use in Hazardous Locations, Class I, Div. 2 Groups A, B, C, D T4 including Class I Zone 2 IIC.

Technical Data		700-321-1FH00	700-321-1EL00
<b>Number of inputs</b>		16	32
<b>Isolation to backplane bus</b>		Yes (optocoupler)	Yes (optocoupler)
• in groups		4	8
<b>Input voltage</b>		120/230 V AC	120 V AC
• nom. value (input voltage must be equal on all phases)			
• for Signal "0"		0 ... 40 V	0 ... 20 V
• for Signal "1"		79 ... 264 V	74 ... 132 V
• frequency range		47 ... 63 Hz	47 ... 63 Hz
<b>Input current for signal "1"</b>			
• 120 V, 60 Hz	typ.	8 mA	22 mA
• 230 V, 50 Hz	typ.	13 mA	-
<b>Delay time</b>			
• from "0" to "1"	typ.	25 ms	15 ms
• from "1" to "0"	typ.	25 ms	25 ms
<b>Cable length</b>			
• unshielded	max.	600 m	600 m
• shielded	max.	1000 m	1000 m
<b>Current consumption</b>			
• internal	max	30 mA	16 mA
<b>Power loss</b>	typ.	4.5 W	5.8 W
<b>Ambient temperature</b>		0 °C ... +60 °C	0 °C ... +60 °C
<b>Transport and storage temperature</b>		-25 °C ... +75 °C	-25 °C ... +75 °C

Ordering Data	Order No.
<b>DEA 300</b> 16 inputs, AC 120 V/230 V 32 inputs, AC 120 V	<b>700-321-1FH00</b> <b>700-321-1EL00</b>
<b>Manual DEA 300, German/English</b>	<b>900-321-1DE11</b>

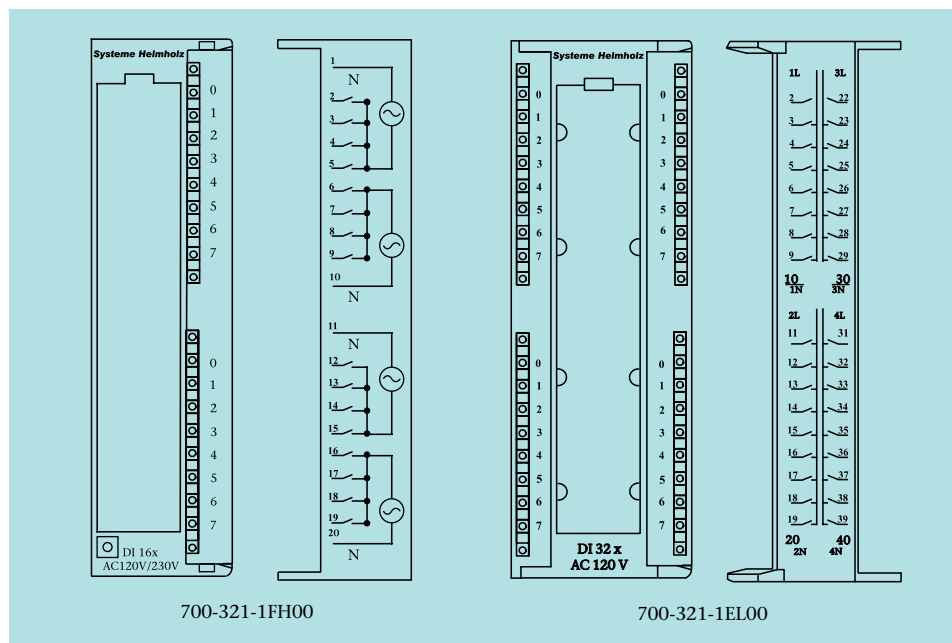

## AEA 300, Analog Input Module for Connecting Sensors with Current Signals



Analog input module

The analog input modules from the Systeme Helmholtz GmbH convert the analog signals from the process to the internal signal level of the programmable controllers.

This module is suitable for connection of sensors with current signals in the range up to  $\pm 20$  mA.

The signal lines are connected to the corresponding front connectors. You can identify them on the labeling strip.

The modules can be fully parameterized with the hardware configurator of the programming software. Hardware configuration is not necessary (**no** range card).

### Accessory-Note

The Systeme Helmholtz GmbH supplies front connectors and cable sets (see page 34–36).



Open type Programmable Controllers, for use in Hazardous Locations, Class I, Div. 2 Groups A, B, C, D T6 including Class I Zone 2, IIC.

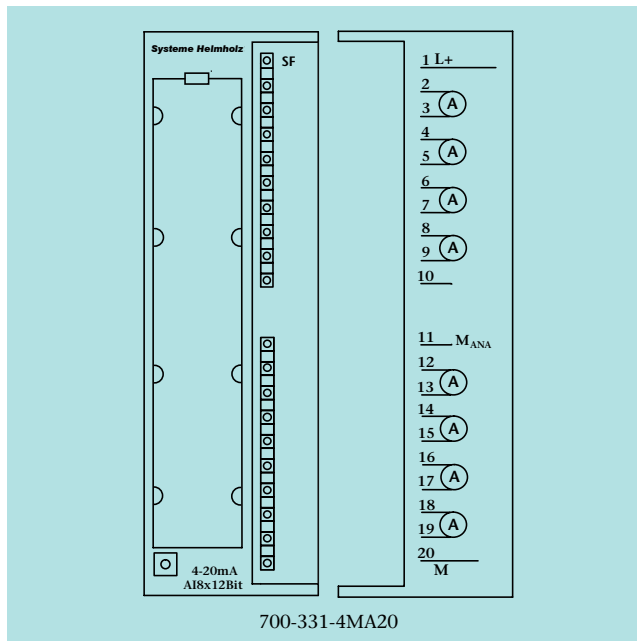

700-331-4MA20

Technical Data	
Number of inputs	8
Alarms	Parameterizable Parameterizable for channels 0 and 2
<ul style="list-style-type: none"> <li>limit value alarm</li> <li>diagnostic alarm</li> </ul>	
Diagnostics	Red LED for group error display
Nom. load voltage L+/L-	DC 24 V
Polarity reversal protection	Yes
Input ranges	
<ul style="list-style-type: none"> <li>current, 4 DMU</li> </ul>	$\pm 3.2$ mA/25 $\Omega$ $\pm 10$ mA/25 $\Omega$ 0 ... 20 mA/25 $\Omega$ 4 ... 20 mA/25 $\Omega$ $\pm 20$ mA/25 $\Omega$ 4 ... 20 mA/25 $\Omega$
<ul style="list-style-type: none"> <li>current, 2 DMU</li> </ul>	$\pm 20$ mA/25 $\Omega$ 4 ... 20 mA/25 $\Omega$
Permissible input current for current input max.	40 mA
Isolation against backplane bus	Yes
Conversion time/resolution (per chann.)	
<ul style="list-style-type: none"> <li>integration time</li> <li>noise suppression for interference frequency</li> <li>resolution (SG = sign) (depends on integration time)</li> </ul>	2.5/16.6/20/100 ms 400/60/50/10 Hz 9 + VZ / 12 + VZ / 12 + VZ / 14 + VZ Bit
Operational limit	max. $\pm 0.6\%$
Basic error limit at 25 °C	max. $\pm 0.5\%$
Cable length (shielded)	200 m
Current consumption	
<ul style="list-style-type: none"> <li>internal (backplane bus)</li> <li>external (L+)</li> </ul>	typ. 120 mA max. 200 mA
Power loss	typ. 1.8 W
Front connector	20-way
Ambient temperature	0 °C ... +60 °C
Transport and storage temperature	-25 °C ... +75 °C

Ordering Data	
	Order No.
AEA 300 8 current inputs for connecting current sensors	700-331-4MA20
Manual AEA 300, German/English	900-331-0AA01

## AEA 300, Analog Input Module for Connecting Sensors with Voltage Signals



Analog input module

The analog input modules from the Systeme Helmholtz GmbH convert the analog signals from the process to the internal signal level of the programmable controllers.

This module is suitable for connection of sensors with voltage signals in the range up to  $\pm 10$  V.

The signal lines are connected to the corresponding front connectors. You can identify them on the labeling strip.

The modules can be fully parameterized with the hardware configurator of the programming software. Hardware configuration is not necessary (**no** name card).

### Accessory-Note

The Systeme Helmholtz GmbH supplies front connectors and cable sets (see page 34–36).



Open type Programmable Controllers, for use in Hazardous Locations, Class I, Div. 2 Groups A, B, C, D T6 including Class I Zone 2, IIC.

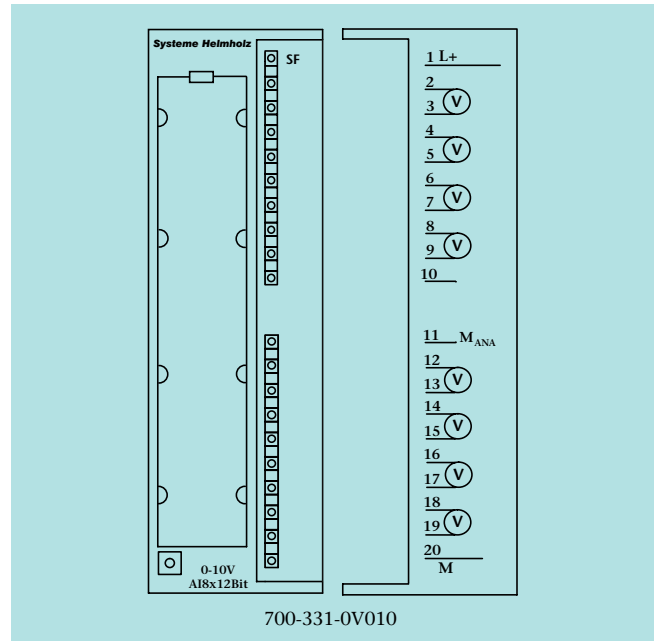

### Technical Data

Number of inputs	8
Alarms	Parameterizable Parameterizable for channels 0 and 2
<ul style="list-style-type: none"> <li>diagnostic alarm</li> <li>limit value alarm</li> </ul>	
Diagnostics	Red LED for group error display
Nom. load voltage L+/L-	DC 24 V
Polarity reversal protection	Yes
Input ranges	
Voltage/input impedance	$\pm 80$ mV/10 M $\Omega$ $\pm 250$ mV/10 M $\Omega$ $\pm 500$ mV/10 M $\Omega$ $\pm 1$ V/10 M $\Omega$ $\pm 2.5$ V/100 k $\Omega$ $\pm 5$ V/100 k $\Omega$ 1 ... 5 V/100 k $\Omega$ $\pm 10$ V/100 k $\Omega$
Permiss. input voltage for voltage input	max. 20 V
Isolation against backplane bus	Yes
Conversion time/resolution (per channel)	
<ul style="list-style-type: none"> <li>integration time</li> <li>noise suppression for interference frequency</li> <li>resolution (SG = sign) (depends on integration time)</li> </ul>	2.5/16.6/20/100 ms 400/60/50/10 Hz 9 + VZ / 12 + VZ / 12 + VZ / 14 + VZ Bit
Operational limit	max. $\pm 0.6\%$
Basic error limit at 25 °C	max. $\pm 0.5\%$
Cable length (shielded)	max. 200 m (50 m at $\pm 80$ mV)
Current consumption	
<ul style="list-style-type: none"> <li>internal (backplane bus)</li> <li>external (L+)</li> </ul>	typ. 120 mA max. 200 mA
Power loss	typ. 1.8 W
Front connector	20-way
Ambient temperature	0 °C ... +60 °C
Transport and storage temperature	-25 °C ... +75 °C

### Ordering Data

	Order No.
<b>AEA 300</b> 8 voltage inputs, for connection of voltage sensors	<b>700-331-0V010</b>
<b>Manual AEA 300</b> , German/English	<b>900-331-0AA01</b>

## AEA 300, Analog Input Module for Connecting Resistance Thermometers



Analog input module

The analog input modules from the Systeme Helmholtz GmbH convert the analog signals from the process to the internal signal level of the programmable controllers.

This module is suitable for connection of Pt100/Ni100 sensors and resistors.

The signal lines are connected to the corresponding front connectors. You can identify them on the labeling strip.

The modules can be fully parameterized with the hardware configurator of the programming software. Hardware configuration is not necessary (**no** range card).

### Accessory-Note

The Systeme Helmholtz GmbH supplies front connectors and cable sets (see page 34–36).



Open type Programmable Controllers, for use in Hazardous Locations, Class I, Div. 2 Groups A, B, C, D T6 including Class I Zone 2, IIC.

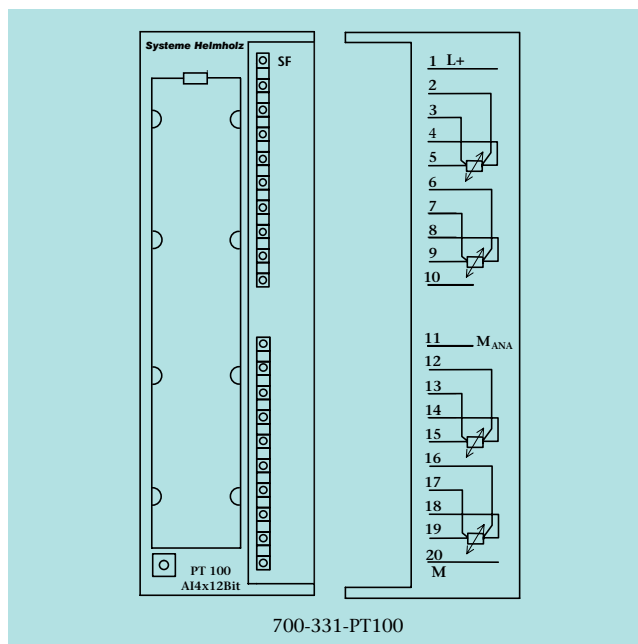

Technical Data	
Number of inputs	4
Alarms	Parameterizable Parameterizable for channels 0 and 2
<ul style="list-style-type: none"> <li>limit value alarm</li> <li>diagnostic alarm</li> </ul>	
Diagnostics	Red LED for group error display
Nom. load voltage L+/L-	DC 24 V
Polarity reversal protection	Yes
Input resistance	10 MΩ
Resistance thermometer	Pt100, Ni100 (standard and climatic range)
Resistance range	100, 150, 600 Ω
Sensor connection	2-, 3- or 4-wire connection
Isolation against backplane bus	Yes
Conversion time/resolution (per channel)	
<ul style="list-style-type: none"> <li>integration time</li> <li>noise suppression for interference frequency</li> <li>resolution (SG = sign) (depends on integration time)</li> </ul>	2,5/16,6/20/100 ms 400/60/50/10 Hz 9 + VZ/12 + VZ/ 12 + VZ/14 + VZ Bit
Operational limit	max. ±0.6%
Basic error limit at 25 °C	max. ±0.5%
Cable length (shielded)	max. 200 m
Current consumption	
<ul style="list-style-type: none"> <li>internal (backplane bus)</li> <li>external (L+)</li> </ul>	typ. 120 mA max. 200 mA
Power loss	typ. 1,8 W
Front connector	20-way
Ambient temperature	0 °C ... +60 °C
Transport and storage temperature	-25 °C ... +75 °C

Ordering Data	
	Order No.
AEA 300 4 inputs, Pt100/Ni100 resistance thermometers	700-331-PT100
Manual AEA 300, German/English	900-331-0AA01



## AEA 300, Analog Input Module Current Signals, Voltage Signals, Resistance, Resistance Thermometer



Analog input module, 8 channel, current signals, voltage signals, resistance, resistance thermometer

The analog input modules from the Systeme Helmholtz GmbH convert the analog signals from the process to the internal signal level of the programmable controllers.

This module is suitable for connection of sensors with current signals in the range up to  $\pm 20$  mA, of sensors with voltage signals in the range up to  $\pm 10$  V, of Pt100/Ni100 sensors and resistors. The signal lines are connected to the corresponding front connectors. You can identify them on the labeling strip. The modules can be fully parameterized with the hardware configurator of the programming software. Hardware configuration is not necessary (no range card).

#### Accessory-Note

The Systeme Helmholtz GmbH supplies front connectors and cable sets (see page 34–36).

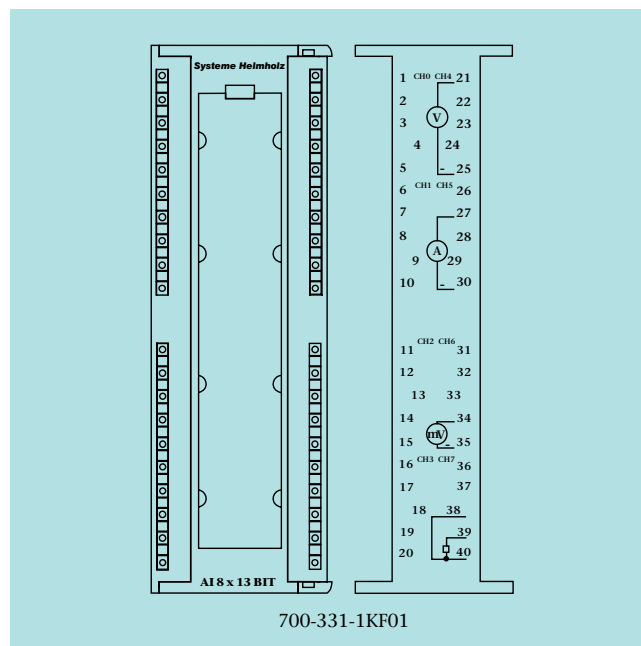

Ordering Data	
	Order No.
<b>AEA 300</b> 8 inputs, for connection of current signals, voltage signals, resistance thermometer	<b>700-331-1KF01</b>
<b>Manual AEA 300, German/English</b>	<b>900-331-0AA01</b>

Technical Data	
<b>Number of inputs</b>	<b>8</b>
<b>Measurement</b>	
• voltage	$\pm 50$ mV, $\pm 500$ mV, $\pm 1$ V, $\pm 5$ V, $\pm 10$ V, 1 ... 5V, 0 ... 10 V
• current	$\pm 20$ mA, 0 ... 20 mA, 4 ... 20 mA
• resistance	0 ... 6 k $\Omega$ , 0 ... 600 $\Omega$
• resistance thermometer (standard and climate)	Pt100, Ni100, Ni1000, LG-Ni1000
Resolution incl. overrange	13 Bit
<b>Error limit</b>	
Basic error limit	at 25 °C
• voltage input	$\pm 0.4\%$
• current input	$\pm 0.4\%$
• resistance	$\pm 0.4\%$
• resistance thermometer	$\pm 0.8$ K Pt100 standard, $\pm K$
<b>Operator limit</b>	
• current input	In the whole temperature range
• resistance	$\pm 0.6\%$
• resistance thermometer	$\pm 1$ K; Pt100, Ni100 standard $\pm 1.2$ K
• voltage input	$\pm 0.6\%$
<b>Supply voltage</b>	
Nominal voltage	DC 5 V by backplane bus
Current demand	Typ. 160 mA at 5 V (from backplane bus)
Power loss	Approx. 0.8 W
Front connector	32 Bit-DEA300 Front connector (40-way)
Ambient temperature	0 °C ... +60 °C
Transport and storage temperature	-25 °C ... +75 °C

## AEA 300, Analog Output Module; 4-Channel



4-channel analog output module

The analog output modules from the Systeme Helmholz GmbH convert the internal signal level of the programmable controllers to the analog signal level required for the process. This module is suitable for connection of analog actuators for voltage and current outputs in the range up to  $\pm 10$  V or  $\pm 20$  mA. The signal lines are connected to the corresponding front connectors. You can identify them on the labeling strip. The modules can be fully configured with the programming software. Hardware switchover is not necessary.

**Accessory-Note**

The Systeme Helmholz GmbH supplies front connectors and cable sets (see page 34–36).

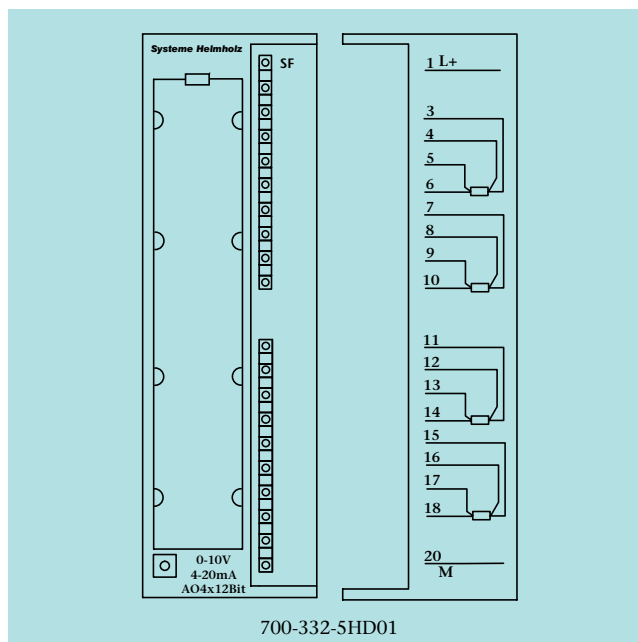

Open type Programmable Controllers, for use in Hazardous Locations, Class I, Div. 2 Groups A, B, C, D T6 including Class I Zone 2, IIC.

**Technical Data**

<b>Number of outputs</b>	4
Diagnostics alarm	Yes, parameterizable
Diagnostics	Red LED for group error display
Nom. load voltage	DC 24 V
<b>Output ranges</b>	
• voltage outputs	0 ... 10 V; $\pm 10$ V; 1 ... 5 V
• current outputs	4 ... 20 mA; $\pm 20$ mA; 0 ... 20 mA
<b>Load impedance</b>	
• for voltage outputs	min. 1 k $\Omega$
• for current outputs	max. 500 $\Omega$
• at capacitive load	max. 1 $\mu$ F
• at inductive load	max. 10 mH
<b>Voltage output</b>	
• short-circuit protection	Yes
• short-circuit current	max. 25 mA
<b>Current output</b>	
• open-circuit voltage	max. 18 V
Isolation against backplane bus	Yes
<b>Operational limit</b> (0 to 60 °C, with reference to output range)	
• voltage	$\pm 0.5$ %
• current	$\pm 0.6$ %
<b>Basic error limit</b> (operational limit at 25 °C, with reference to output range)	
• voltage	$\pm 0.4$ %
• current	$\pm 0.5$ %
Cable length (shielded)	max. 200 m
<b>Current consumption</b>	
• internal (from backplane bus)	typ. 100 mA
• external, without load	max. 240 mA
Power loss	typ. 3 W
Front connector	20-way
Ambient temperature	0 °C ... +60 °C
Transport and storage temperature	-25 °C ... +75 °C

Ordering Data	
	Order No.
AEA 300, 4-channel 4 outputs for connecting analog actuators	700-332-5HD01
Manual AEA 300, German/English	900-331-0AA01

## AEA 300, Analog Output Modules; 2-Channel



2-channel analog output module

The analog output modules from the Systeme Helmholtz GmbH convert the internal signal level of the programmable controllers to the analog signal level required for the process. This module is suitable for connection of analog actuators for voltage and current outputs in the range up to  $\pm 10$  V or  $\pm 20$  mA. The signal lines are connected to the corresponding front connectors. You can identify them on the labeling strip. The modules can be fully configured with the programming software. Hardware switchover is not necessary.

**Accessory-Note**

The Systeme Helmholtz GmbH supplies front connectors and cable sets (see page 34–36).



Open type Programmable Controllers, for use in Hazardous Locations, Class I, Div. 2 Groups A, B, C, D T6 including Class I Zone 2, IIC.

Ordering Data	
	Order No.
AEA 300, 2-channel 2 outputs for connecting analog actuators	700-332-5HB01
Manual AEA 300, German/English	900-331-0AA01

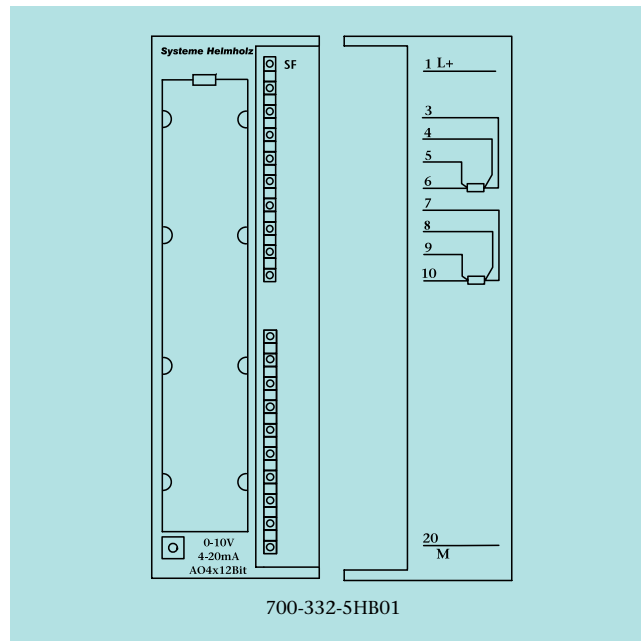
**Technical Data**

<b>Number of outputs</b>	2	
Diagnostics alarm	Yes, parameterizable	
Diagnostics	Red LED for group error display	
Nom. load voltage	DC 24 V	
<b>Output ranges</b>		
• voltage outputs	0 ... 10 V; $\pm 10$ V; 1 ... 5 V	
• current outputs	4 ... 20 mA; $\pm 20$ mA; 0 ... 20 mA	
<b>Load impedance</b>		
• for voltage outputs	min.	1 k $\Omega$
• for current outputs	max.	500 $\Omega$
• at capacitive load	max.	1 $\mu$ F
• at inductive load	max.	10 mH
<b>Voltage output</b>		
• short-circuit protection		Yes
• short-circuit current	max.	25 mA
<b>Current output</b>		
• open-circuit voltage	max.	18 V
Isolation against backplane bus	Yes	
<b>Operational limit</b> (0 to 60 °C, with reference to output range)		
• voltage		$\pm 0.5\%$
• current		$\pm 0.6\%$
<b>Basic error limit</b> (operational limit at 25 °C, with reference to output range)		
• voltage		$\pm 0.4\%$
• current		$\pm 0.5\%$
Cable length (shielded)	max.	200 m
<b>Current consumption</b>		
• internal (from backplane bus)	typ.	100 mA
• external, without load	max.	240 mA
Power loss	typ.	3 W
Front connector	20-way	
Ambient temperature	0 °C ... +60 °C	
Transport and storage temperature	-25 °C ... +75 °C	

## Dummy module



Dummy module

The Dummy module from the Systeme Helmholtz GmbH is for reserving slots for unparameterized signal modules. The structure and address assignment is retained when it is eventually replaced by a signal module. For 20-way or 40-way front connectors.

### Meaning of the 8/9-Bit display of the placeholder module

There are two different methods of transmitting data on the backplane bus of the S7-300<sup>1)</sup>:

- **without parity Bit**

Only the data bytes (8 Bits) are transmitted.

This method is obsolete because errors during transmission cannot be detected and the I/Os may be incorrectly switched.

- **with parity Bit**

The new safe method transmits a parity bit in addition to the useful data (9 Bits per byte). That way transmission errors can be detected and incorrect connections avoided.

The CPUs known to us are capable of both transmission methods. Due to reasons of downward compatibility all I/O modules that are capable of the 9-Bit method can also be switched back to the 8-Bit method. This occurs when at least one module is plugged into the system that is only capable of the 8-Bit method.

The 8/9-Bit LEDs indicate which method the complete system is using.

If an 8-Bit module is used, all 9-Bit modules on the backplane will only use 8-Bit transmission.

The 9-bit method was introduced shortly after the market launch of the S7-300<sup>1)</sup>.

However, to ensure downward compatibility, new CPUs are still capable of the 8-Bit method.

Ordering Data	
	Order No.
Dummy module, 20-way	700-370-0AA01
Dummy module, 40-way	700-370-0AL01
Manual DEA 300, German/English	900-321-1DE11

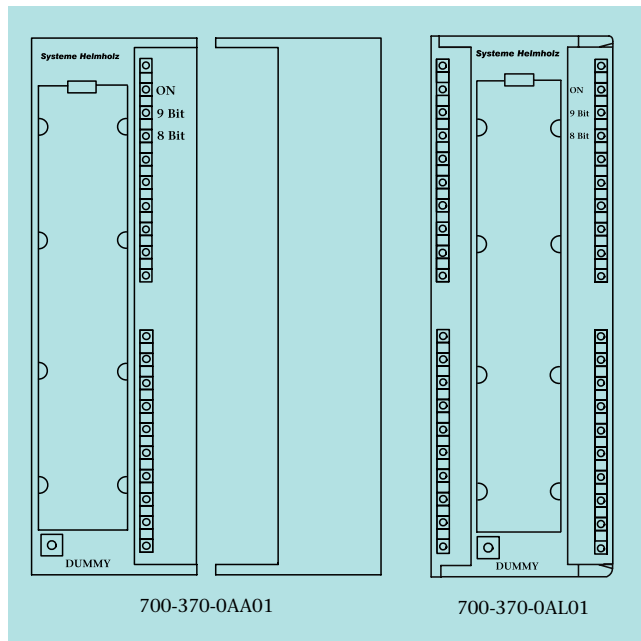

Systeme Helmholtz modules all use the reliable 9-Bit method when possible.

However, there are modules possessing just the 8-Bit method on the market. To ensure reliable data transmission on the backplane bus and avoid incorrect switching, we advise against using such modules. The presence of 8-Bit modules can be seen by the shining of the red 8-Bit LED of the placeholder module.

Technical Data	
Current consumption Internal	5 mA
Power loss (nominal operation)	0.03 W
Front connector	-
Ambient temperature Transport and storage temperature	0 °C ... 60 °C -25 °C ... 75 °C

1) S7-300 is a registered trademark of Siemens AG

## PAS 153, distributed PROFIBUS Interface



PAS 153

The PAS 153 distributed PROFIBUS Interface from Systeme Helmholz GmbH is for linking digital and analog input and output modules to the PROFIBUS-DP. The module can be mounted on a sectional rail.

Up to 16 modules can be connected to the PAS 153. The PAS 153 is integrated into the hardware configurator of the programming system by a GSD file. The PAS 153 Interface performs all communication between the modular I/O device and the higher-level master unit on the PROFIBUS-DP. The inputs and outputs are assigned to the master in the configuration. Diagnostic information from the modules can be read out via the PAS 153 Interface in the usual way.

The PAS 153 Interface supports all input/output modules from Systeme Helmholz GmbH and numerous modules of the same type from other manufacturers.

The scope of modules supported can be extended at any time by a firmware update via the USB.

## Features

- DIP switch for setting the PROFIBUS address
- Up to 16 modules can be plugged in
- Module diagnostics supported
- Can be used on standard sectional rail
- Any combination of modules is possible (analog/digital)
- PROFIBUS-DP up to 12 Mbps
- GSD file is supplied
- Firmware update for expanding functions possible via USB

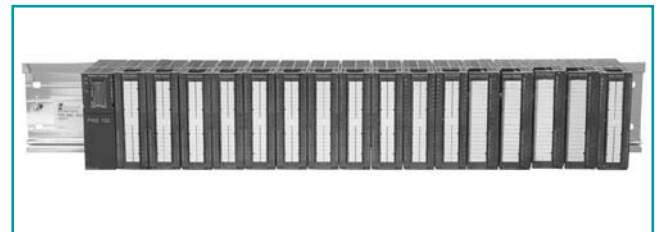

Up to 16 modules can be plugged in



Ordering Data	
	Order No.
PAS 153, distributed PROFIBUS Interface (incl. CD with GSD file)	700-153-1AA03
Manual PAS 153, German/English	900-153-1AA03

Technical Data	
Dimensions (D x W x H mm)	116 x 40 x 125
Weight	Approx. 250 g
<b>Power supply</b>	
Voltage	DC 24 V
Current consumption	max. 625 mA
Output voltage	DC 5 V
Output current at DC 5 V	max. 1.5 A (to backplane)
<b>PROFIBUS Interface</b>	
Transmission rate	max. 12 Mbps, autodetection
Protocol	PROFIBUS-DP to EN 50 170
Addressrange	128 Bytes for inputs 128 Bytes for outputs
Module count	max. 16, 8 of these analog
Connection	Male, SUB-D, 9-way
Ambient temperature	0 °C ... +60 °C
Transport and storage temperature	-25 °C ... +60 °C

## SAS 340, Communication Module



SAS 340

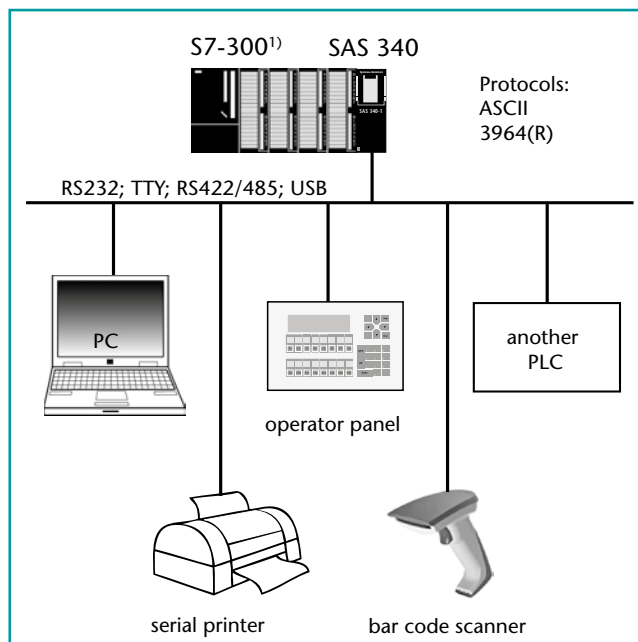

Application example for SAS 340

The SAS 340 is a serial communication module for use in Simatic<sup>1)</sup> S7-300<sup>1)</sup> systems. The SAS 340 permits the linking to the PLC of serial devices, such as barcode scanners, operator terminals, serial printers, PCs, PLCs of other manufacturers, and supports the ASCII and 3964R protocols.

The serial devices can be connected via RS232, TTY (20 mA), or RS422/RS485. The 9-way Sub-D socket (15-way in the case of RS422/485) with standard pin assignment is provided for connecting communicating devices.

The additional USB-device interface permits the connection of the PLC to PC systems, many of which no longer have a conventional physical port. A virtual COM port driver enables the use of software that still expects a COM port.

Extended functions, such as support for higher baud rates up to 115 kBaud make the SAS 340 all the more versatile without any loss of compatibility.

The data handling blocks supplied enable simple and flexible integration into the PLC. The module is parameterized in the Hardware Configurator of the PLC. Extended functions (e.g. higher baud rates) can be activated with the data handling blocks without any problem.

To permit a higher integration density in the cabinet, the SAS 340 is also available with 2 serial interfaces. Both interfaces can be parameterized independently and are used in the PLC.

Ordering Data	
	Order No.
SAS 340-1*, 1 x RS232, 1 x USB	700-340-1AH02
SAS 340-1*, 1 x TTY	700-340-1BH02
SAS 340-1*, 1 x RS422/RS485	700-340-1CH02
SAS 340-2*, 2 x RS232, 2 x USB	700-340-2AH02
SAS 340-2*, 2 x TTY	700-340-2BH02
SAS 340-2*, 2 x RS422/RS485	700-340-2CH02
*(incl. CD with data handling blocks and manual)	
Manual SAS 340, German/English	900-340-1XH02

1) Simatic and S7-300 are registered trademarks of Siemens AG.

Technical Data	
Dimensions (D x W x H mm)	116 x 40 x 125
Weight	Approx. 280 g
<b>Power supply</b>	
Voltage	+5 V DC via backplane bus
Current consumption	typ. 160 mA max. 190 mA
<b>Interfaces</b>	
Type	V.24 (RS232) TTY (20 mA) RS422/RS485 (X27) USB
Transmission rate	300 Baud ... 115 kBaud
Protocol	ASCII 3964(R)
Connection	Connector, SUB-D, 9-way; 15-way (RS422/485)
Status display	6 LEDs
Ambient temperature	0 °C ... 60 °C
Transport and storage temperature	-25 °C ... 75 °C

## SAS 341, Communication Module



SAS 341

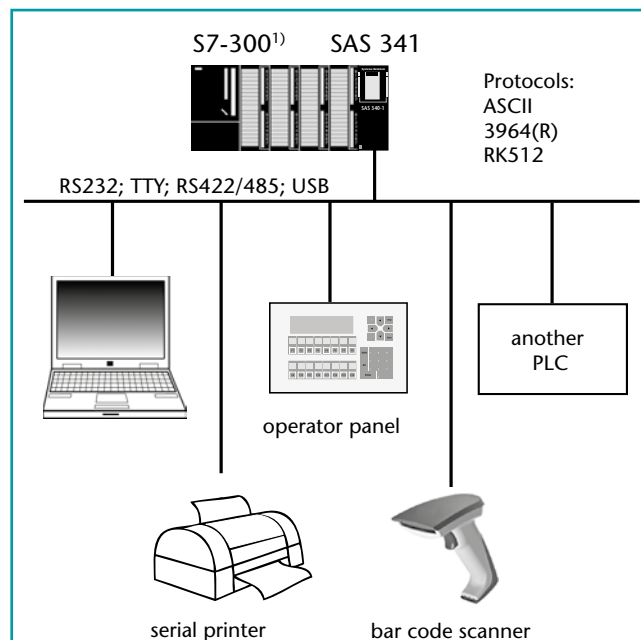

Application example for SAS 341

The SAS 341 is a serial communication module for use in Simatic<sup>1)</sup> S7-300<sup>1)</sup> systems. The SAS 341 permits the linking to the PLC of serial devices, such as barcode scanners, operator terminals, serial printers, PCs, PLCs of other manufacturers, and supports the ASCII, 3964R, and RK512 protocols.

The serial devices can be connected via RS232, TTY (20 mA), or RS422/RS485. The 9-way Sub-D socket (15-way in the case of RS422/485) with standard pin assignment is provided for connecting communicating devices.

The additional USB interface permits the connection of the PLC to PC systems, many of which no longer have a conventional physical port. A virtual COM port driver enables the use of software that still expects a COM port.

Extended functions, such as support for higher baud rates up to 115 kBaud make the SAS 341 all the more versatile without any loss of compatibility.

Using the standardized RK512 computer link protocol, the linking of different types of PLC to the S7-300<sup>1)</sup> can be flexibly implemented.

The data handling blocks supplied enable simple and flexible integration into the PLC. The module is parameterized in the Hardware Configurator of the PLC. To permit a higher integration density in the cabinet, the SAS 341 is also available with 2 serial interfaces. Both interfaces can be parameterized independently and are used in the PLC.

Ordering Data	
	Order No.
SAS 341-1*, 1 x RS232, 1 x USB	700-341-1AH02
SAS 341-1*, 1 x TTY	700-341-1BH02
SAS 341-1*, 1 x RS422/RS485	700-341-1CH02
SAS 341-2*, 2 x RS232, 2 x USB	700-341-2AH02
SAS 341-2*, 2 x TTY	700-341-2BH02
SAS 341-2*, 2 x RS422/RS485	700-341-2CH02
*(incl. CD with data handling blocks and manual)	
Modbus Master/Slave Driver for SAS 341 (on Micro Memory Card)	800-341-MOD01
Manual SAS 341, German/English	900-341-1XH02

1) Simatic and S7-300 are registered trademarks of Siemens AG.

Via an optionally obtainable Micro Memory Card, customer-specific protocol drivers can be loaded into the SAS 341. Special drivers, such as Modbus can be implemented in this way.

*Do you require a special protocol for your device? Just ask us!*

Technical Data	
Dimensions (D x W x H mm)	116 x 40 x 125
Weight	Approx. 280 g
<b>Power supply</b>	
Voltage	+5 V DC via backplane bus
Current consumption	typ. 160 mA max. 190 mA
<b>Interfaces</b>	
Type	V.24 (RS232) TTY (20 mA) RS422/RS485 (X27) USB
Transmission rate	300 Baud ... 115 kBaud
Protocol	ASCII 3964(R) RK512
Connection	Connector, SUB-D, 9-way; 15-way (RS422/485)
Status display	6 LEDs
Ambient temperature	0 °C ... 60 °C
Transport and storage temperature	-25 °C ... 75 °C

## EIB 300, Communication Module for Twisted Pair EIB/KNX



EIB 300

The EIB 300 is a communication module for use in Simatic<sup>1)</sup> S7-300<sup>1)</sup> systems. It enables the connection of an EIB/KNX bus to the PLC whereby the bus is directly attached to the module. Due to the possibilities of PLC programming, complex control and monitoring functions can also be realised easily on the EIB/KNX bus.

Two different operating modes are supported for flexible use of the EIB 300.

In the “object mode”, the EIB 300 is an active participant on the EIB/KNX bus with up to 240 objects whereby all object types from 1 bit to 4 bytes data size are supported. The current object values are mapped in a data module in the PLC and exchanged with each PLC cycle. In this way, value changes on the EIB side are applied in the PLC and changed values in the PLC are transmitted on the EIB/KNX bus. This can also be influenced using event and control flags targeted to the communications behaviour.

In the “telegram mode”, all telegrams transmitted on the EIB/KNX bus are transparently forwarded to the PLC and any telegrams can be sent out on the EIB/KNX bus from the PLC. This operating mode enables maximum flexibility, also in the case of complex systems or communications processes.

The management of the EIB 300 is performed in the PLC as CP module. The handling modules contained in the standard delivery enable simple integration of the EIB 300 in the PLC program. The integration of the EIB 300 in the ETS software as a new device is performed using a supplied example project. In the object mode, the objects organised there in different profiles can be configured and thus adapted to the respective application. Six coloured LEDs provide information about the current operating status of the EIB 300 and the EIB/KNX bus. The installed USB port is provided for firmware updates and in-depth diagnostics.

### Features

- Access to the EIB/KNX bus directly from the PLC
- Realisation of complex control and monitoring functions using PLC programming
- Configurable object operation with up to 240 objects
- Telegram mode for the transparent EIB/KNX communication
- Easy integration and handling

Ordering Data	
	Order No.
EIB 300, Communication Module for Twisted Pair EIB/KNX	700-820-EIB01
Manual EIB 300, German/English	900-820-EIB01

Technical Data		
Dimensions (D x W x H mm)		116 x 40 x 125
Weight		Approx. 280 g
<b>Power supply</b>		
Voltage		DC +5 V via backplane bus
Current consumption		typ. 160 mA max. 190 mA
<b>Interface</b>		
Type		Twisted Pair EIB/KNX
Transmission rate		9600 Baud
Protocol		EIB/KNX; up to 240 objects or telegram mode
Connection		2-pin
Status display		6 LEDs
Ambient temperature		0 °C ... 60 °C
Transport and storage temperature		-25 °C ... 75 °C

1) Simatic and S7-300 are registered trademarks of Siemens AG.



## EIB 300, Communication Module for Twisted Pair EIB/KNX

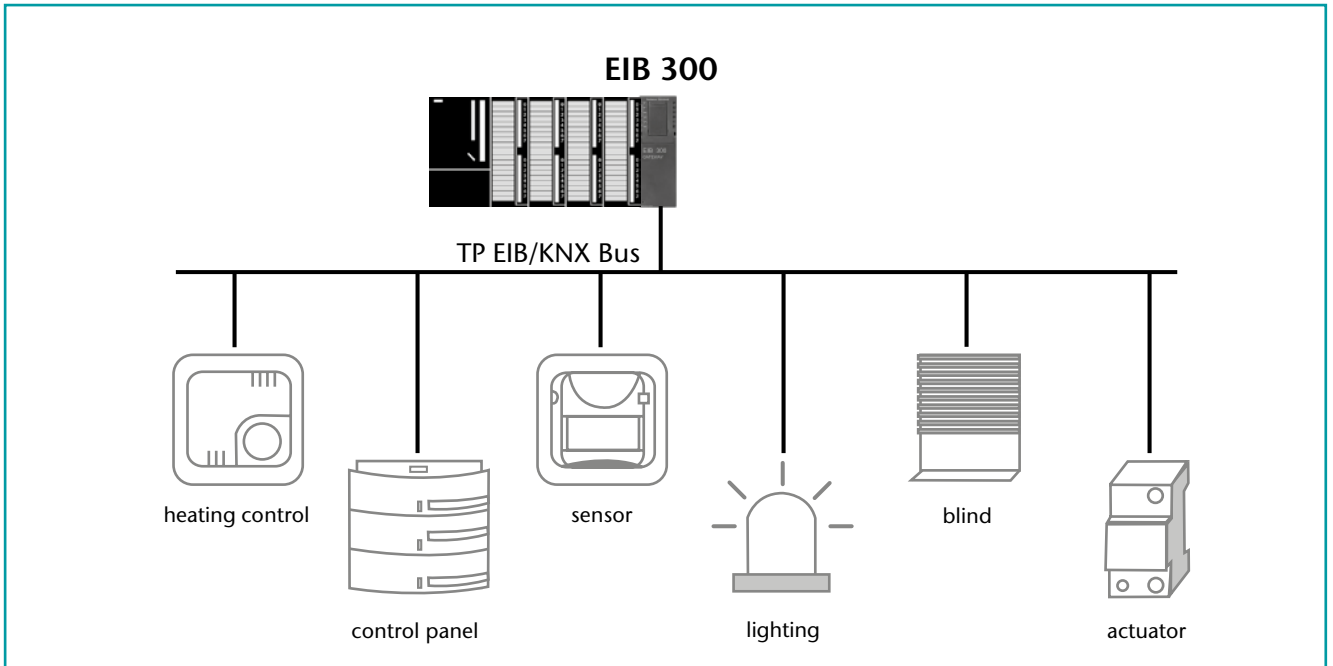

Application Example EIB 300

The screenshot shows the ETS3 software interface for configuring the EIB 300 module. The main window displays a table of objects with the following columns: Number, Name, Object Function, Description, Group Ad..., Length, C, R, W, T, U, and Data Typ.

Number	Name	Object Function	Description	Group Ad...	Length	C	R	W	T	U	Data Typ
209	0	Tx Object 209		13/0/36	2 Byte	C	-	W	T	-	
210	0	Tx Object 210		13/0/69	2 Byte	C	-	W	T	-	
211	0	Tx Object 211		13/1/0	2 Byte	C	-	W	T	-	
212	Rx	Object 212	2 Input Bytes @ D8B90-91	1/6/0	2 Byte	C	-	W	T	U	2 byte flo.
213	Rx	Object 213	2 Input Bytes @ D8B92-93	1/7/1	2 Byte	C	-	W	T	U	2 byte flo.
214	Rx	Object 214	2 Input Bytes @ D8B94-95	1/5/10	2 Byte	C	-	W	T	U	2 byte flo.
215	Rx	Object 215	2 Input Bytes @ D8B96-97	1/5/20	2 Byte	C	-	W	T	U	2 byte flo.
216	Rx	Object 216	2 Input Bytes @ D8B98-99	4/0/0	2 Byte	C	-	W	T	U	2 byte flo.
217	Rx	Object 217	2 Input Bytes @ D8B100-101	4/0/1	2 Byte	C	-	W	T	U	2 byte flo.
218	Rx	Object 218	2 Input Bytes @ D8B102-103	4/0/2	2 Byte	C	-	W	T	U	2 byte flo.
219	Rx	Object 219	2 Input Bytes @ D8B104-105	4/0/3	2 Byte	C	-	W	T	U	2 byte flo.
220	Rx	Object 220	2 Input Bytes @ D8B106-107	4/0/4	2 Byte	C	-	W	T	U	2 byte flo.
221	Rx	Object 221	2 Input Bytes @ D8B108-109	4/0/5	2 Byte	C	-	W	T	U	2 byte flo.
222	0	Tx Object 222		4/1/0	3 Byte	C	R	-	T	-	
223	0	Tx Object 223		4/1/1	3 Byte	C	R	-	T	-	
224	0	Tx Object 224		15/1/2	4 Byte	C	-	W	T	-	4 byte flo.
225	0	Tx Object 225		15/1/3	4 Byte	C	-	W	T	-	4 byte sig
226	Rx	Object 226	4 Input Bytes @ D8B124-127	15/1/3	4 Byte	C	-	W	T	U	

The bottom section of the screenshot shows the 'Group Addresses in Helmholz' window, which lists various objects and their associated devices, such as 'Ausgang 12 - Schalten' and 'Halle HV A1.1 Schalt-/Jalousieaktor 16-/8fach 16A REG'.

Configuration of EIB 300 at ETS3

## FastPlug, Frontadapter for S7 modules



**FastPlug** – Frontadapter for S7 modules

The new professional **FastPlug** Frontadapter from the Systeme Helmholtz GmbH are intended for insertion or clipping on a 16 or 32 Bit S7 Input/Output module. They are reducing the wiring effort. Through the use of prefabricated system cables, connection errors are excluded. Therefore the interface modules/transfer modules can be connected fast & safe to the S7 PLC.

The new **FastPlug** Frontadapter are available to be connected to a 16 Bit Input/Output module with a 20pin ribbon connector and a 2 x 20pin ribbon connector for 32 Bit Input/Output module.

### Features

- Frontadapter for ribbon connector
- 20-way and 40-way
- Fast, safe and cost-effective wiring
- Connection errors excluded

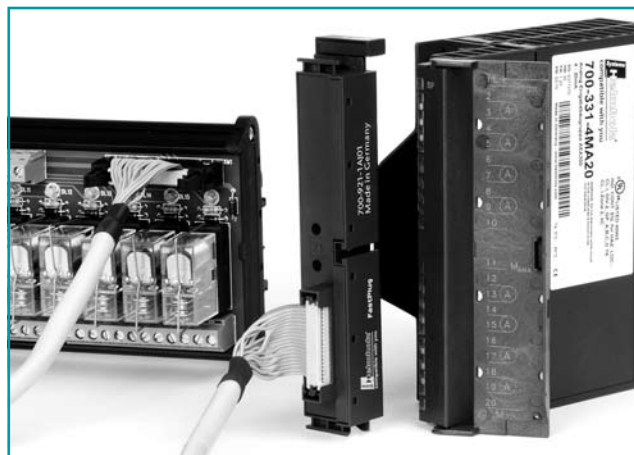

Ordering Data	
	Order No.
<b>Front Connector for DEA 300</b>	
<b>FastPlug</b> 20-way, S7 Frontadapter	700-921-1AJ01
<b>FastPlug</b> 40-way, S7 Frontadapter	700-921-1AM01
<b>Twisted ribbon cable, unshielded,</b> 20-way, 2 ID-connectors	
0.5 m	700-923-2BA50
1.0 m	700-923-2BB00
1.5 m	700-923-2BB50
2.0 m	700-923-2BC00
2.5 m	700-923-2BC50
3.0 m	700-923-2BD00
4.0 m	700-923-2BE00
5.0 m	700-923-2BF00

Technical Data	
<b>Front Connector Connection</b> 700-921-1AJ01 700-921-1AM01	<b>FastPlug</b> 1 x 20-way IDC 2 x 20-way IDC
Weight	Approx. 50 g
Dimensions (D x W x H mm) 700-921-1AJ01 700-921-1AM01	131 x 23 x 31 116 x 22 x 30
Voltage	Max. 48 V AC/DC between any terminals
Current consumption	Max. 600 mA per terminal
Ambient temperature Transport and storage temperature Relative humidity	0 °C ... +60 °C -25 °C ... +80 °C max. 75% at +25 °C

## Front Connectors with screw contacts, Front Connectors **EasyConnect**<sup>®</sup>



Front Connectors, 20-way and 40-way with screw contacts

### Front Connector with screw connections

The 20-way and 40-way front connector from the Systeme Helmholz GmbH uses time-tested screw connections. The front connector permits simple connection of sensors and actuators to input/output modules of Systeme Helmholz GmbH or other manufacturers.

The wiring can thus be retained even in the event of module replacement.



Front Connector, 40-way with **EasyConnect**<sup>®</sup> technology

### Front Connector with **EasyConnect**<sup>®</sup> technology

The 40-way front connector from the Systeme Helmholz GmbH is supplied with **EasyConnect**<sup>®</sup> technology. The connector is quickly wired up simply by opening and closing the spring-loaded terminal by turning the screw head (180° counterclockwise to open, clockwise to close). That not only saves the user money but also installation time.

No wire end ferrule is needed!

The flat design permits optimum closing of the module front cover even with the connector fully wired.

Technical Data	
<b>Front Connector 20-way</b>	
Connection	Screw-type terminals
Connectable cables W/o wire end ferrule	Flexible, fixed 0.25 - 1.5 mm <sup>2</sup>
Strip length	6 mm
Max. tightening torque	0.5 Nm
Weight	Approx. 60 g
Current at 60 °C	3 A
Voltage	230 V AC
Ambient temperature	0 °C ... +60 °C
Transport and storage temperature	-25 °C ... +80 °C
Relative humidity	max. 75% at +25 °C
<b>Front Connector 40-way</b>	
Connection	screw-type terminals
Connectable cables W/o wire end ferrule	Flexible, fixed 0.125 - 1.5 mm <sup>2</sup>
Strip length	6 - 8 mm
Max. tightening torque	0.5 Nm
Weight	Approx. 120 g
Current at 60 °C	3 A
Voltage	230 V AC
Ambient temperature	0 °C ... +60 °C
Transport and storage temperature	-25 °C ... +80 °C
Relative humidity	max. 75% at +25 °C

Technical Data	
<b>Front Connector 40-way</b>	
Connection	<b>EasyConnect</b> <sup>®</sup>
Connectable cables W/o wire end ferrule	Flexible, fixed 0.34 - 1 mm <sup>2</sup>
Strip length	8 - 10 mm
Weight	Approx. 70 g
Current at 60 °C	3 A
Voltage	230 V AC
Ambient temperature	0 °C ... +60 °C
Transport and storage temperature	-25 °C ... +80 °C
Relative humidity	max. 75% at +25 °C

Ordering Data	
	Order No.
<b>Front Connector for DEA 300</b>	
20-way with screw contacts	700-392-1AJ10
40-way with screw contacts	700-392-1AM01
40-way with <b>EasyConnect</b> <sup>®</sup> technology	700-392-1AM10

## Front Connectors with spring contacts, Ready-wired Front Connectors



Front Connectors, 20-way and 40-way with spring contacts

### Front Connector with spring contacts

The 20-way and 40-way front connector from the Systeme Helmholtz GmbH uses spring contacts. The front connector permits simple connection of sensors and actuators to input/output modules of Systeme Helmholtz GmbH or other manufacturers. The wiring can thus be retained even in the event of module replacement.



Ready-wired Front Connectors

### Ready-wired Front Connector

The Ready-wired front connectors are available for easy connection of sensors and actuators to input/output modules of Systeme Helmholtz GmbH.

The cabling can be kept when modules are replaced.

Technical Data	
<b>Front Connector 20-way</b>	
Connection type	Spring contacts
Connectable cables <b>with/without wire end ferrules</b>	Flexible, fixed 0.34 - 1.5 mm <sup>2</sup>
Insulation stripping length	8 mm
Weight	Approx. 50 g
Current at 60 °C	3 A
Voltage	230 V AC
Ambient temperature	0 °C ... +60 °C
Transport and storage temperature	-25 °C ... +80 °C
Relative humidity max.	75 % at +25 °C
<b>Front Connector 40-way</b>	
Connection type	Spring contacts
Connectable cables <b>with/without wire end ferrules</b>	Flexible, fixed 0.34 - 1.5 mm <sup>2</sup>
Insulation stripping length	8 mm
Weight	Approx. 70 g
Current at 60 °C	3 A
Voltage	230 V AC
Ambient temperature	0 °C ... +60 °C
Transport and storage temperature	-25 °C ... +80 °C
Relative humidity max.	75 % at +25 °C

Ordering Data	
	Order No.
<b>Front Connector for DEA 300</b>	
20-way with spring contacts	700-392-1BJ01
40-way with spring contacts	700-392-1BM01

Ordering Data	
	Order No.
<b>Ready-wired Front Connectors<sup>1)</sup></b>	
<b>DEA 300</b>	
for screw connection, 20-way, 2 m	700-392-1AJ10A
for screw connection, 20-way, 3 m	700-392-1AJ10B
for screw connection, 20-way, 5 m	700-392-1AJ10C
for <b>EasyConnect</b> <sup>®</sup> connection, 40-way, 2 m	700-392-1AM10A
for <b>EasyConnect</b> <sup>®</sup> connection, 40-way, 3 m	700-392-1AM10B
for <b>EasyConnect</b> <sup>®</sup> connection, 40-way, 5 m	700-392-1AM10C
for spring contacts, 20-way, 2 m	700-392-1BJ01A
for spring contacts, 20-way, 3 m	700-392-1BJ01B
for spring contacts, 20-way, 5 m	700-392-1BJ01C
for spring contacts, 40-way, 2 m	700-392-1BM01A
for spring contacts, 40-way, 3 m	700-392-1BM01B
for spring contacts, 40-way, 5 m	700-392-1BM01C

1) Strands 0.5 mm<sup>2</sup> blue (RAL 5010); Labeling as on connector

## Mounting rail, Mounting rail adapter for DIN rail

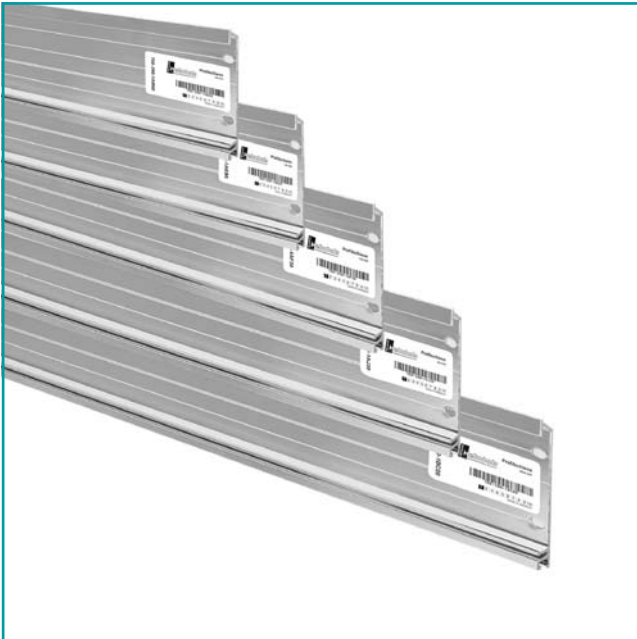

Mounting rail

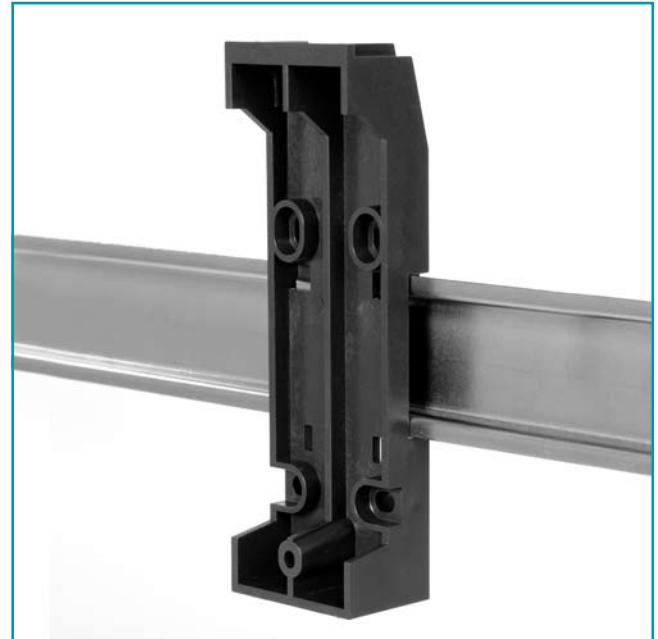

Mounting rail adapter for DIN rail

For all DEA and AEA etc., we offer the mechanical module subrack for the S7-300<sup>1)</sup> as an accessory in various lengths.

We offer for all communication modules (e.g. REX 300, DP/DP-Koppler, TS 300, MDM 300) which are designed for assembling on mounting rail a mounting rail adapter for DIN rail as an accessory.

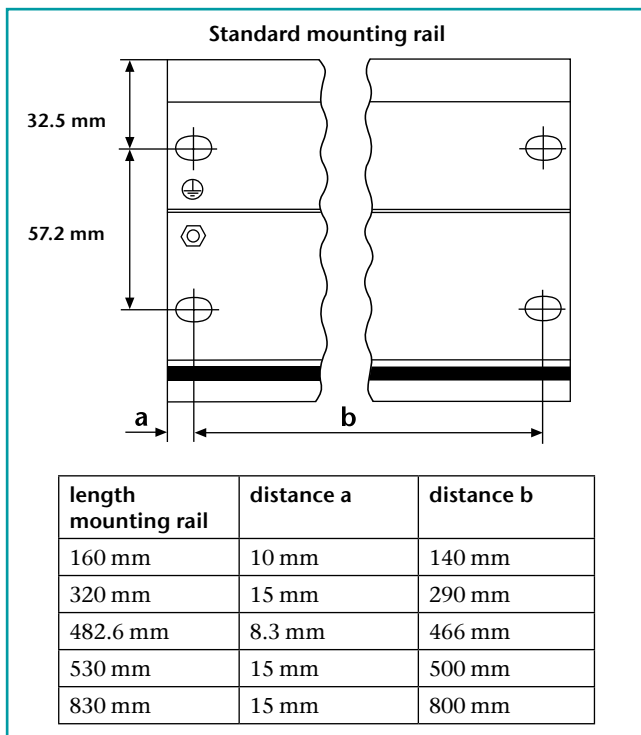

### Ordering Data

	Order No.
<b>Mounting rail</b>	
length 160 mm	700-390-1AB60
length 320 mm	700-390-1SO01
length 482 mm	700-390-1AE80
length 530 mm	700-390-1AF30
length 830 mm	700-390-1AJ30
length 2000 mm	700-390-1BC00

### Ordering Data

	Order No.
<b>Mounting rail adapter for DIN rail</b>	700-390-6BA01

1) S7-300 is a registered trademark of Siemens AG.



# PROFIBUS

Bus Connectors  
Repeater  
Active Dropcable  
Terminal Block  
DP/DP Coupler

## PROFIBUS Connector, 90°

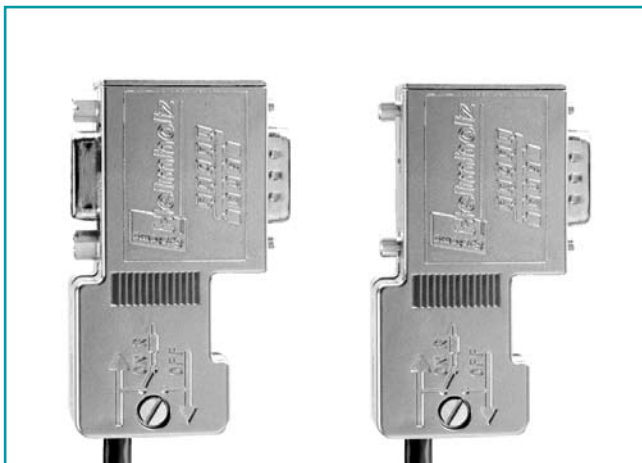

Bus connector for PROFIBUS with (l.) and without (r.) prog. device connector

With their compact design, the bus connectors of Systeme Helmholtz GmbH are ideal for connecting PROFIBUS stations. A slide switch sets whether the connector will be used as a node or end of segment. The switch can also be operated when the connector is plugged. The switch setting is clearly visible. The connector must be used as a node ("OFF") when the incoming bus and the outgoing bus are to be interconnected. This deactivates the terminating resistors. The connector must be set as a segment end ("ON") on the first and last (extreme) stations of the segment. In that case the terminating resistors are connected on the incoming bus, the outgoing bus is disconnected.

### Features

- Metalized housing
- No loosable parts
- Integrated terminating resistor
- 90° cable outlet
- Small housing
- Screw terminals



Ordering Data	
	Order No.
PROFIBUS Connector, 90° without prog. device connector	700-972-0BA12
with prog. device connector 90°	700-972-0BB12
Stripping tool for PROFIBUS	700-972-6AA00

The PROFIBUS connectors are also available in boxes containing 10 or 50 pieces.

1) FastConnect is a registered trademark of Siemens AG.

Technical Data	
<b>Programming device connector</b> Order No. 700-972-0BB12 Order No. 700-972-0BA12	<b>Yes</b> <b>No</b>
Dimensions (D x W x H mm)	64 x 40 x 17
Weight	Approx. 40 g
Outgoing cable	Vertical outgoing cable suitable for FastConnect <sup>1)</sup> stripping tool
Terminating resistor	Resistor combination integrated and connectable with slide switch
Transmission rate max.	12 Mbps
<b>Interfaces</b> PROFIBUS station	SUB-D connector, 9-way
Max. outside diameter	8.0 mm
PROFIBUS cable	60/75 °C copper wire up to 1.0 mm <sup>2</sup>
Connection type	4 terminals
Voltage consumption	4.75 ... 5.25 V DC (must come from connected equip.)
Current consumption max.	12.5 mA
Environmental pollution degree	2
Ambient temperature Transport and storage temperature	0 °C ... +60 °C -25 °C ... +80 °C
Relative humidity max.	75% at +25 °C
Degree of protection	IP 20

## PROFIBUS Connector, 35°

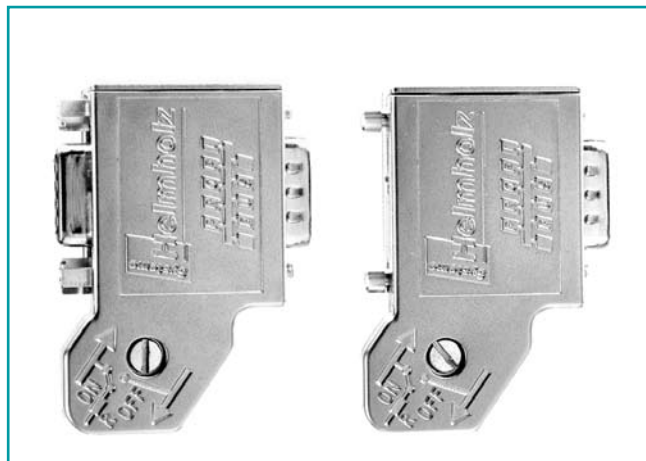

Bus connector for PROFIBUS, with 35° cable outlet

The 35° bus connector for PROFIBUS is a further component in our range of connectors providing you with low-cost alternatives for your automation.

The bus connectors are used to connect a PROFIBUS station to the PROFIBUS cable. The connector is quickly mounted and features integrated terminating resistors.

The Systeme Helmholz GmbH offers the bus connector with an 35° cable outlet and for transmission rates up to 12 Mbps.

### Features

- Metalized housing
- No loosable parts
- Integrated switchable terminating resistor
- 35° cable outlet
- Small housing
- Screw terminals

**CAUS**

**PROFI**  
PROCESS FIELD BUS  
**BUS**

Ordering Data	
	Order No.
PROFIBUS Connector, 35° without prog. device connector	700-972-0BA41
with prog. device connector	700-972-0BB41

The PROFIBUS connectors are also available in boxes containing 10 or 50 pieces.

Technical Data	
<b>Programming device connector</b> Order No. 700-972-0BB41 Order No. 700-972-0BA41	<b>Yes</b> <b>No</b>
Dimensions (D x W x H mm)	54 x 40 x 17
Weight	Approx. 40 g
Outgoing cable	35° outgoing cable
Terminating resistor	Resistor combination integrated and connectable with slide switch
Transmission rate max.	12 Mbps
<b>Interfaces</b> PROFIBUS station	SUB-D connector, 9-way
Max. outside diameter	8.0 mm
PROFIBUS cable	60/75 °C copper wire up to 1.0 mm <sup>2</sup>
Connection type	4 terminals
Voltage consumption	4.75 ... 5.25 V DC (must come from connected equip.)
Current consumption max.	12.5 mA
Environmental pollution degree	2
Ambient temperature Transport and storage temperature	0 °C ... +60 °C -25 °C ... +80 °C
Relative humidity max.	75 % at +25 °C
Degree of protection	IP 20



## PROFIBUS Connector, axial



Bus connector for PROFIBUS, with axial cable outlet

The axial bus connector for PROFIBUS is a further component in our range of connectors providing you with low-cost alternatives for your automation.

The bus connector is used to connect PROFIBUS stations to the PROFIBUS cable. The connector is quickly mounted. In addition, the terminating resistors are already integrated.

The Systeme Helmholtz GmbH offers the bus connector with an axial cable outlet and for transmission rates up to 12 Mbps.

## Features

- Metalized housing
- Integrated switchable terminating resistor
- No loosable parts
- Axial cable outlet
- Screw terminals

Ordering Data	
	Order No.
PROFIBUS Connector, axial axial cable outlet	700-972-0CA12

The PROFIBUS connectors are also available in boxes containing 10 or 50 pieces

1) FastConnect is a registered trademark of Siemens AG.

Technical Data	
Dimensions (D x W x H mm)	68 x 39.5 x 17
Weight	Approx. 40 g
Outgoing cable, axial	Axial outgoing cable, suitable for FastConnect <sup>1)</sup> stripping tool
Terminating resistor	Resistor combination integrated and connectable with slide switch
Transmission rate	max. 12 Mbps
<b>Interfaces</b> PROFIBUS station	SUB-D connector, 9-way
Max. outside diameter	8.0 mm
PROFIBUS cable	60/75 °C copper wire up to 1.0 mm <sup>2</sup>
Connection type	4 terminals
Voltage consumption	4.75 ... 5.25 V DC (must come from connected equip.)
Current consumption	max. 12.5 mA
Environmental pollution degree	2
Ambient temperature	0 °C ... +60 °C
Transport and storage temperature	-25 °C ... +80 °C
Relative humidity	max. 75% at +25 °C
Degree of protection	IP 20

## PROFIBUS Connector, 90° EasyConnect®

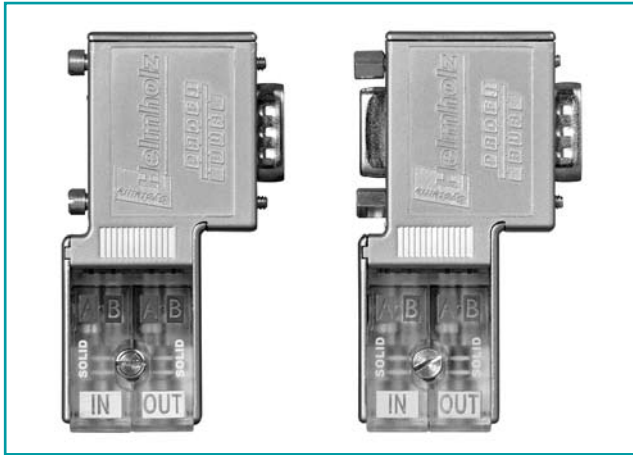

Bus connector for PROFIBUS, **EasyConnect®**

The **EasyConnect®** connector features quick-connect technology, which makes stripping the bus wires superfluous. The bus connector is used to connect PROFIBUS stations to the PROFIBUS cable. The connector is quickly mounted. The housing is metal-coated for improved electromagnetic compatibility. In addition, the terminating resistors are already integrated. The Systeme Helmholz GmbH offers the **EasyConnect®** connector with a perpendicular cable outlet. Once the cable has been installed it is easy to check (visual inspection) that the PROFIBUS cable has been correctly connected. The **EasyConnect®** connector also works in the extended ambient temperature range of -25 °C to +70 °C with immediate effect.

### Features

- Metalized housing
- No loosable parts
- **EasyConnect®** technology
- Visual connection control
- Integrated terminating resistor
- 90° cable outlet
- Small housing



Ordering Data	
	Order No.
PROFIBUS Connector, 90° <b>EasyConnect®</b> for solid cables without progr. device connector with progr. device connector	700-972-0BA50 700-972-0BB50
PROFIBUS Connector, 90° <b>EasyConnect®</b> for flexible cables without progr. device connector 90° with progr. device connector 90°	700-972-0FA50 700-972-0FB50
Stripping tool for PROFIBUS	700-972-6AA00

**EasyConnect®** is a registered trademark of Systeme Helmholz GmbH.  
1) FastConnect is a registered trademark of Siemens AG.

Technical Data	
Programming device connector Order No. 700-972-0BB50/-0FB50 Order No. 700-972-0BA50/-0FA50	Yes No
Dimensions (D x W x H mm)	72 x 40 x 17
Weight	Approx. 40 g
Outgoing cable	Vertical outgoing cable suitable for FastConnect <sup>1)</sup> stripping tool
Terminating resistor	Resistor combination integrated and connectable with slide switch
Transmission rate max.	12 Mbps
<b>Interfaces</b> PROFIBUS station	SUB-D connector, 9-way
Max. outside diameter	8.0 mm
PROFIBUS cable	FC standard cable solid or flexible; 0.64 mm Ø 60/75 °C copper wire
Connection type	<b>EasyConnect®</b>
Voltage consumption	4.75 ... 5.25 V DC (must come from connected equip.)
Current consumption max.	12.5 mA
Environmental pollution degree	2
Ambient temperature Transport and storage temperature Relative humidity max.	0 °C ... +60 °C -25 °C ... +80 °C 75% at +25 °C
Degree of protection	IP 20

## PROFIBUS Connector, angled **EasyConnect**<sup>®</sup>



Bus connector for PROFIBUS, angled **EasyConnect**<sup>®</sup>

The new angled **EasyConnect**<sup>®</sup> bus connector for PROFIBUS of Systeme Helmholtz GmbH features quick-connect technology, which makes stripping the bus wires superfluous.

The bus connector is used to connect PROFIBUS stations to the PROFIBUS cable. The connector is quickly mounted.

The housing is metal-coated for improved electromagnetic compatibility. In addition, the terminating resistors are already integrated. Once the cable has been installed it is easy to check (visual inspection) that the PROFIBUS cable has been correctly connected.

### Features

- Metalized housing
- No loosable parts
- **EasyConnect**<sup>®</sup> technology
- Visual connection control
- Integrated terminating resistor
- Angled cable outlet
- Small housing



Ordering Data	
	Order No.
<b>PROFIBUS Connector, angled <b>EasyConnect</b><sup>®</sup> for solid cables</b>	
without prog. device connector	700-972-0BA51
with prog. device connector	700-972-0BB51
<b>PROFIBUS Connector, angled <b>EasyConnect</b><sup>®</sup> for flexible cables</b>	
without prog. device connector	700-972-0FA51
with prog. device connector	700-972-0FB51

Technical Data	
<b>Programming device connector</b>	<b>Yes</b>
Order No. 700-972-0BB51/-0FB51	<b>No</b>
Order No. 700-972-0BA51/-0FA51	
Dimensions (D x W x H mm)	95 x 70 x 17
Weight	Approx. 50 g
Outgoing cable	Angled outgoing cable
Terminating resistor	Resistor combination integrated and connectable with slide switch
Transmission rate	max. 12 Mbps
<b>Interfaces</b>	
PROFIBUS station	SUB-D connector, 9-way
Max. outside diameter	8.0 mm
PROFIBUS cable	FC standard cable solid or flexible; 0.64 mm Ø 60/75 °C copper wire
Connection type	<b>EasyConnect</b> <sup>®</sup>
Voltage consumption	4.75 ... 5.25 V DC (must come from connected equip.)
Current consumption	max. 12.5 mA
Environmental pollution degree	2
Ambient temperature	0 °C ... +60 °C
Transport and storage temperature	-25 °C ... +80 °C
Relative humidity	max. 75 % at +25 °C
Degree of protection	IP 20

## PROFIBUS Connector, axial EasyConnect®



Bus connector for PROFIBUS, axial EasyConnect®

The **EasyConnect®** connector axial features quick-connect technology, which makes stripping the bus wires superfluous. The bus connector is used to connect PROFIBUS stations to the PROFIBUS cable. The connector is quickly mounted, and has a metallized housing and integrated terminating resistors. Once the cable has been installed it is easy to check (visual inspection) that the PROFIBUS cable has been correctly connected. The **EasyConnect®** connector also works in the extended ambient temperature range of -25 °C to +70 °C with immediate effect.

### Features

- Metallized housing
- No loosable parts
- Integrated terminating-resistor
- Visual connection control
- **EasyConnect®** technology
- Axial cable outlet



Ordering Data	
	Order No.
<b>PROFIBUS Connector, axial EasyConnect®</b> for solid cables	700-972-0CA50
for flexible cables	700-972-0CF50

1) FastConnect is a registered trademark of Siemens AG.

Technical Data	
Dimensions (D x W x H mm)	70 x 35 x 17
Weight	Approx. 50 g
Outgoing cable	Vertical outgoing cable suitable for FastConnect <sup>1)</sup> stripping tool
Terminating resistor	Resistor combination integrated and connectable with slide switch
Transmission rate	max. 12 Mbps
<b>Interfaces</b>	
PROFIBUS station	SUB-D connector, 9-way
Max. outside diameter	8.0 mm
PROFIBUS cable	FC standard cable solid or flexible; 0.64 mm Ø 60/75 °C copper wire
Connection type	<b>EasyConnect®</b>
Voltage consumption	4.75 ... 5.25 V DC (must come from connected equip.)
Current consumption	max. 12.5 mA
Environmental pollution degree	2
Ambient temperature	0 °C ... +60 °C
Transport and storage temperature	-25 °C ... +80 °C
Relative humidity	max. 75% at +25 °C
Degree of protection	IP 20

## PROFIBUS Connector, 90° with diagnostic LEDs, EasyConnect®



Bus connector for PROFIBUS, 90° EasyConnect® with diagnostic LEDs

The **EasyConnect®** diagnostic PROFIBUS connector allows you to build a PROFIBUS network in which the user can always check the state of the bus system at a glance.

The three built-in LEDs in the easily distinguishable colors blue, green, and orange indicate the most important states of the PROFIBUS network at each station.

The state of the terminating resistor (**orange**), whether bus activity is in progress (**green**), and whether the station addressed is participating in bus traffic (**blue**) are all indicated.

This means errors, such as bus interruptions, missing or incorrectly connected terminating resistors, and malfunctioning or failed bus stations can be detected immediately.

The PROFIBUS diagnostic connector with tried-and-tested and reliable screw terminals can be supplied with or without a programmer (PG) jack.

The new **EasyConnect®** connectors feature quick-connect technology, which makes stripping the bus wires superfluous. The bus connector is used to connect a PROFIBUS station to the PROFIBUS cable.

### Features

- 3 LEDs status displays
- Integrated terminating resistors
- No loosable parts
- Small housing
- Visual connection control
- **EasyConnect®** technology



Technical Data	
Programming device connector Order No. 700-972-7BB50/-7FB50 Order No. 700-972-7BA50/-7FA50	<b>Yes</b> <b>No</b>
Dimensions (D x W x H mm)	64 x 40 x 17
Weight	Approx. 40 g
Outgoing cable	Vertical outgoing cable suitable for FastConnect <sup>1)</sup> stripping tool
Terminating resistor	Resistor combination integrated and connectable with slide switch
Transmission rate max.	12 Mbps
<b>Interfaces</b> PROFIBUS station	SUB-D connector, 9-way
Max. outside diameter	8.0 mm
PROFIBUS cable	FC standard cable solid, 0.64 mm Ø 60/75 °C copper wire
Connection type	<b>EasyConnect®</b>
Voltage consumption	4.75 ... 5.25 V DC (must come from connected equip.)
Current consumption max.	35 mA
Environmental pollution degree	2
Ambient temperature Transport and storage temperature	0 °C ... +60 °C -25 °C ... +80 °C
Relative humidity max.	75% at +25 °C
Degree of protection	IP 20

Ordering Data	
	Order No.
<b>PROFIBUS Connector, 90° with diagnostic LEDs EasyConnect® for solid cables</b> without prog. device connector with prog. device connector	700-972-7BA50 700-972-7BB50
<b>PROFIBUS Connector, 90° with diagnostic LEDs EasyConnect® for flexible cables</b> without prog. device connector with prog. device connector	700-972-7FA50 700-972-7FB50
<b>Stripping tool for PROFIBUS</b>	700-972-6AA00

1) FastConnect is a registered trademark of Siemens AG.

## PROFIBUS Connector, 90° with diagnostic LEDs



Bus connector for PROFIBUS, 90° with diagnostic LEDs

The PROFIBUS diagnostic connector can be used to connect a PROFIBUS network in which the user can check the status of the bus system at any time at a glance.

The three built-in LEDs with the easily distinguished colors blue, green and orange indicate the most important states of the PROFIBUS network at each station. The state of the terminating resistor (**orange**), whether bus activity is in progress (**green**) and whether the station addressed is participating in bus traffic (**blue**) are all indicated.

This means errors, such as bus interruptions, missing or incorrectly connected terminating resistors and malfunctioning or failed bus stations can be detected immediately.

The PROFIBUS diagnostic connector with screw terminals can be supplied with or without a programming (PG) device connector.



Ordering Data	
	Order No.
PROFIBUS Connector, 90° with diagnostic LEDs without prog. device connector 90°	700-972-7BA12
with prog. device connector 90°	700-972-7BB12
Stripping tool for PROFIBUS	700-972-6AA00

1) FastConnect is a registered trademark of Siemens AG.

### Features

- 3 status LEDs indicate “bus operation”, “station transmitting”, “terminating resistor inserted”
- Screw terminals
- Integrated switchable terminating resistors
- No loosable parts
- Small housing

Technical Data	
Programming device connector	Yes No
Order No. 700-972-7BB12	Yes
Order No. 700-972-7BA12	No
Dimensions (D x W x H mm)	64 x 40 x 17
Weight	Approx. 40 g
Outgoing cable	Vertical outgoing cable suitable for Fast-Connect <sup>1)</sup> stripping tool
Terminating resistor	Resistor combination integrated and connectable with slide switch
Transmission rate	max. 12 Mbps
<b>Interfaces</b>	
PROFIBUS station	SUB-D connector, 9-way
Max. outside diameter	8.0 mm
PROFIBUS cable	60/75 °C copper wire up to 1.0 mm <sup>2</sup>
Connection type	4 terminals
Voltage consumption	4.75 ... 5.25 V DC (must come from connected equip.)
Current consumption	max. 35 mA
Environmental pollution degree	2
Ambient temperature	0 °C ... +60 °C
Transport and storage temperature	-25 °C ... +80 °C
Relative humidity	max. 75 % at +25 °C
Degree of protection	IP 20

## PROFIBUS Connector with ATEX accreditation

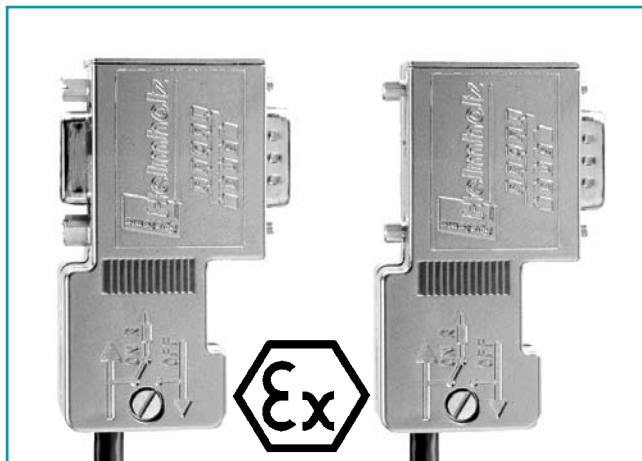

Bus connector for PROFIBUS with (l.) and without (r.) prog. device connector

The bus connectors are used to connect a PROFIBUS station to the PROFIBUS cable. The connector is quickly mounted and has integrated, connectable terminating resistors.

The Systeme Helmholtz GmbH offers the bus connector for usage in explosion hazardous areas of zone 2 (explosive gas atmosphere appears seldom and for very short time).

The bus connector is plugged directly onto the PROFIBUS interface (SUB-D connector, 9-way) of the PROFIBUS stations. The PROFIBUS cables are connected using 4-way screw terminals. Using a slide switch you can set whether the connector is to be used as a node or segment end. The switch can also be operated when the connector is installed. The setting can be clearly seen.

### Features

- Metalized housing
- No loosable parts
- Integrated switchable terminating resistor
- 90° cable outlet
- ATEX accreditation (II 3 G Ex nA II T4)
- Screw terminals



Ordering Data	
	Order No.
<b>PROFIBUS Connector with ATEX accreditation</b>	
without prog. device connector, Ex-Zone 2	700-973-0BA12
with prog. device connector, Ex-Zone 2	700-973-0BB12
<b>Stripping tool for PROFIBUS</b>	700-972-6AA00

1) FastConnect is a registered trademark of Siemens AG.

Technical Data	
<b>Programming device connector</b>	
Order No. 700-973-0BB12	<b>Yes</b>
Order No. 700-973-0BA12	<b>No</b>
Dimensions (D x W x H mm)	64 x 40 x 17
Weight	Approx. 40 g
Outgoing cable	Vertical outgoing cable suitable for FastConnect <sup>1)</sup> stripping tool
Terminating resistor	Resistor combination integrated and connectable with slide switch
Transmission rate	max. 12 Mbps
<b>Interfaces</b>	
PROFIBUS station	SUB-D connector, 9-way
Max. outside diameter	8.0 mm
PROFIBUS cable	60/75 °C copper wire up to 1.0 mm <sup>2</sup>
Connection type	4 terminals
Voltage consumption	4.75 ... 5.25 V DC (must come from connected equip.)
Current consumption	max. 12.5 mA
Environmental pollution degree	2
Ambient temperature	0 °C ... +60 °C
Transport and storage temperature	-25 °C ... +80 °C
Relative humidity	max. 75% at +25 °C
Degree of protection	IP 20

## PROFIBUS Connector with spring type terminals

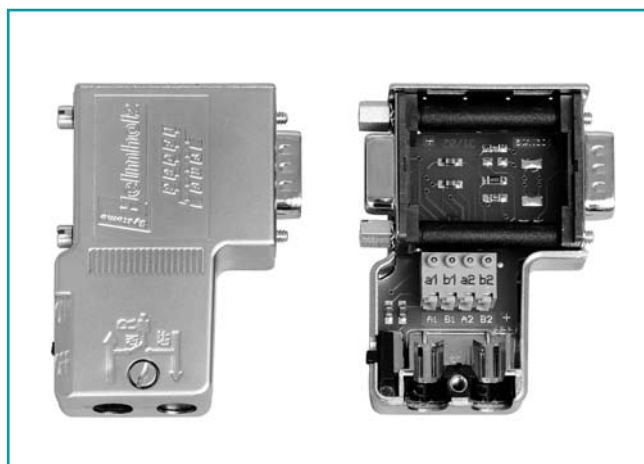

Bus connector for PROFIBUS with spring type terminals

The bus connector is used to connect PROFIBUS stations to a PROFIBUS cable. The connector is quickly mounted and has integrated, connectable terminating resistors.

The spring type terminal is suitable for solid conductors up to a cross section of 0.5 mm<sup>2</sup>. The stripped conductors contacts automatically when inserted, for breaking the connection the orange lever must be pressed.

The bus connector is plugged directly onto the PROFIBUS interface (SUB-D connector, 9-way) of the PROFIBUS stations. The PROFIBUS cables are connected using 4-way spring type terminals.

Using a slide switch, you can set whether the connector is to be used as a node or segment end. The switch can also be operated when the connector is installed. The setting can be clearly seen.

### Features

- Metalized housing
- No loosable parts
- Integrated switchable terminating resistor
- 90° cable outlet
- Spring type terminal



Ordering Data	
	Order No.
PROFIBUS Connector with spring type terminals without prog. device connector	700-982-0BA22
with prog. device connector	700-982-0BB22
Stripping tool for PROFIBUS	700-972-6AA00

1) FastConnect is a registered trademark of Siemens AG.

Technical Data	
Programming device connector	Yes No
Order No. 700-982-0BB22	
Order No. 700-982-0BA22	
Dimensions (D x W x H mm)	65 x 48 x 16
Weight	Approx. 40 g
Outgoing cable	Vertical outgoing cable suitable for FastConnect <sup>1)</sup> stripping tool
Terminating resistor	Resistor combination integrated and connectable with slide switch
Transmission rate	max. 12 Mbps
Interfaces	
PROFIBUS station	SUB-D connector, 9-way
Max. outside diameter	8.0 mm
PROFIBUS cable	60/75 °C copper wire up to 0.5 mm <sup>2</sup>
Connection type	4 spring type terminals
Voltage supply	DC 4.75 ... 5.25 V (must come from connected equip.)
Current consumption	max. 12.5 mA
Environmental pollution degree	2
Ambient temperature	0 °C ... +60 °C
Transport and storage temperature	-25 °C ... +80 °C
Relative humidity	max. 75 % at +25 °C
Degree of protection	IP 20



## PROFIBUS Connector, 90° M12



Bus connector for PROFIBUS, with M12 connection

The new M12 bus connector for PROFIBUS of Systeme Helmholz GmbH is used to connect PROFIBUS stations to a PROFIBUS cable with an M12 connection. The use of prefabricated system cables eliminates connection faults. Assembly effort is reduced to a minimum.

The connector has two M12 connections and integrated terminating resistors. The housing is metal-coated for improved electromagnetic compatibility.

Systeme Helmholz GmbH offers the M12 bus connector with a 90° cable duct for transmission rates up to 12 Mbps.

### Features

- Metalized housing
- No loosable parts
- Integrated switchable terminating resistor
- 90° cable outlet
- M12 connections



Ordering Data	
	Order No.
PROFIBUS Connector, 90° M12 without prog. device connector	700-974-0BA12
PROFIBUS Connector, 90° M12 with prog. device connector	700-974-0BB12

Technical Data	
<b>Programming device connector</b>	
Order No. 700-974-0BB12	Yes
Order No. 700-974-0BA12	No
Dimensions (D x W x H mm)	70 x 40 x 17
Weight	Approx. 60 g
Outgoing cable	Vertical outgoing cable
Terminating resistor	Resistor combination integrated and connectable with slide switch
Transmission rate	max. 12 Mbps
<b>Interfaces</b>	
PROFIBUS station	SUB-D connector, 9-way
Connection type	M12
Voltage consumption	4.75 ... 5.25 V DC (must come from connected equip.)
Current consumption	max. 12.5 mA
Environmental pollution degree	2
Ambient temperature	0 °C ... +60 °C
Transport and storage temperature	-25 °C ... +80 °C
Relative humidity	max. 75% at +25 °C
Degree of protection	IP 20

## FLEXtra® twinRepeater, PROFIBUS Repeater



FLEXtra® twinRepeater

Despite its compact size, the new FLEXtra® twinRepeater from Systeme Helmholz GmbH is a fully functioning PROFIBUS repeater. It is designed for mounting on a DIN rail.

The FLEXtra® twinRepeater regenerates the electrical signal arriving on the bus line and retransmits it (bit reshaping and retransmission). The level, edge steepness, and mark-to-space ratio of the signals are reproduced exactly. It supports transmission rates from 9.6 kbps to 12 Mbps and automatically detects them.

The twinRepeater offers an excellent method of extending the bus (up to 1 km with 2 FLEXtra® twinRepeaters), increasing the number of stations, and expanding the system. Moreover, it can be used in MPI networks. In particular, the FLEXtra® twinRepeater can be used to implement spur lines as independent segments. The status LEDs integrated for each segment provide a clear overview of the current bus status. What is more, the FLEXtra® twinRepeater electrically isolates the two PROFIBUS segments from each other.

The twinRepeater also has a switch for deactivating the repeater function. This separates the segments, which nevertheless each remain able to function. PROFIBUS connectors are required for connection to the PROFIBUS cable (also available as a set).

### Features

- Can be used as bus extension or as a spur line
- Increases the number of stations on the bus
- System expansion
- Can also be used in MPI networks
- Status LEDs per segment
- Repeater function can be deactivated
- Electrical isolation

## FLEXtra twinRepeater

Ordering Data	
	Order No.
FLEXtra® twinRepeater (incl. instruction)	700-972-2AA02
FLEXtra® twinRepeater Set FLEXtra® twinRepeater, 2 PROFIBUS Connectors screw terminals 90° with PG (incl. instruction)	700-972-2XA02

Technical Data	
Dimensions (D x W x H mm)	35 x 44 x 72
Weight	Approx. 110 g
Power supply	18 ... 30 VDC
Output voltage	5 V
Potential separation	500 V
Current consumption	max. 60 mA
Segment connection	Via PROFIBUS Connector
<b>PROFIBUS interface</b>	
Transmission rate	max. 12 Mbps autodetection
Protocol	PROFIBUS-DP to EN 61 158-2
Ambient temperature	0 °C ... +60 °C
Transport and storage temperature	-25 °C ... +75 °C
Degree of protection	IP 20

FLEXtra® twinRepeater, PROFIBUS Repeater

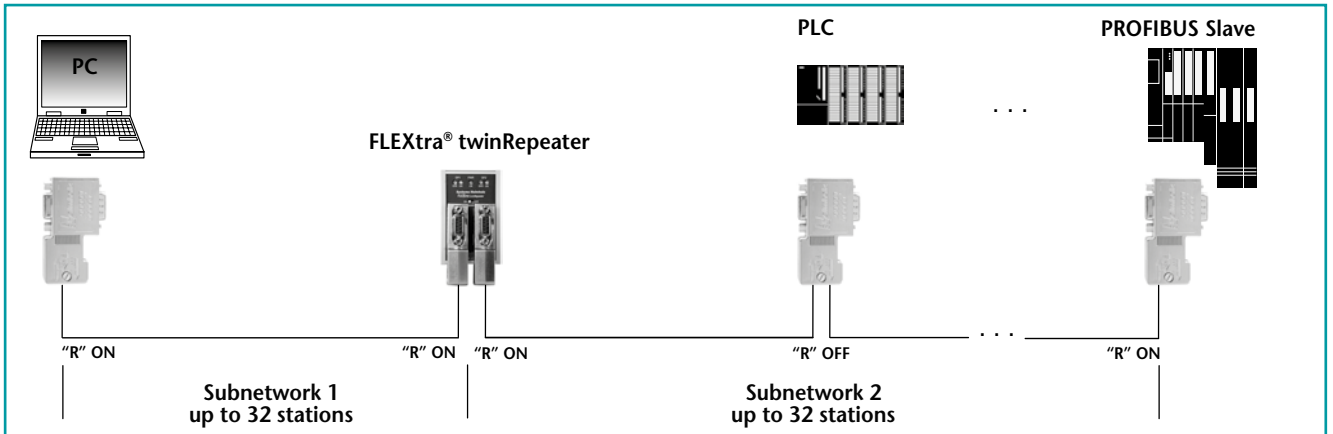

Application example FLEXtra® twinRepeater with more than 32 stations

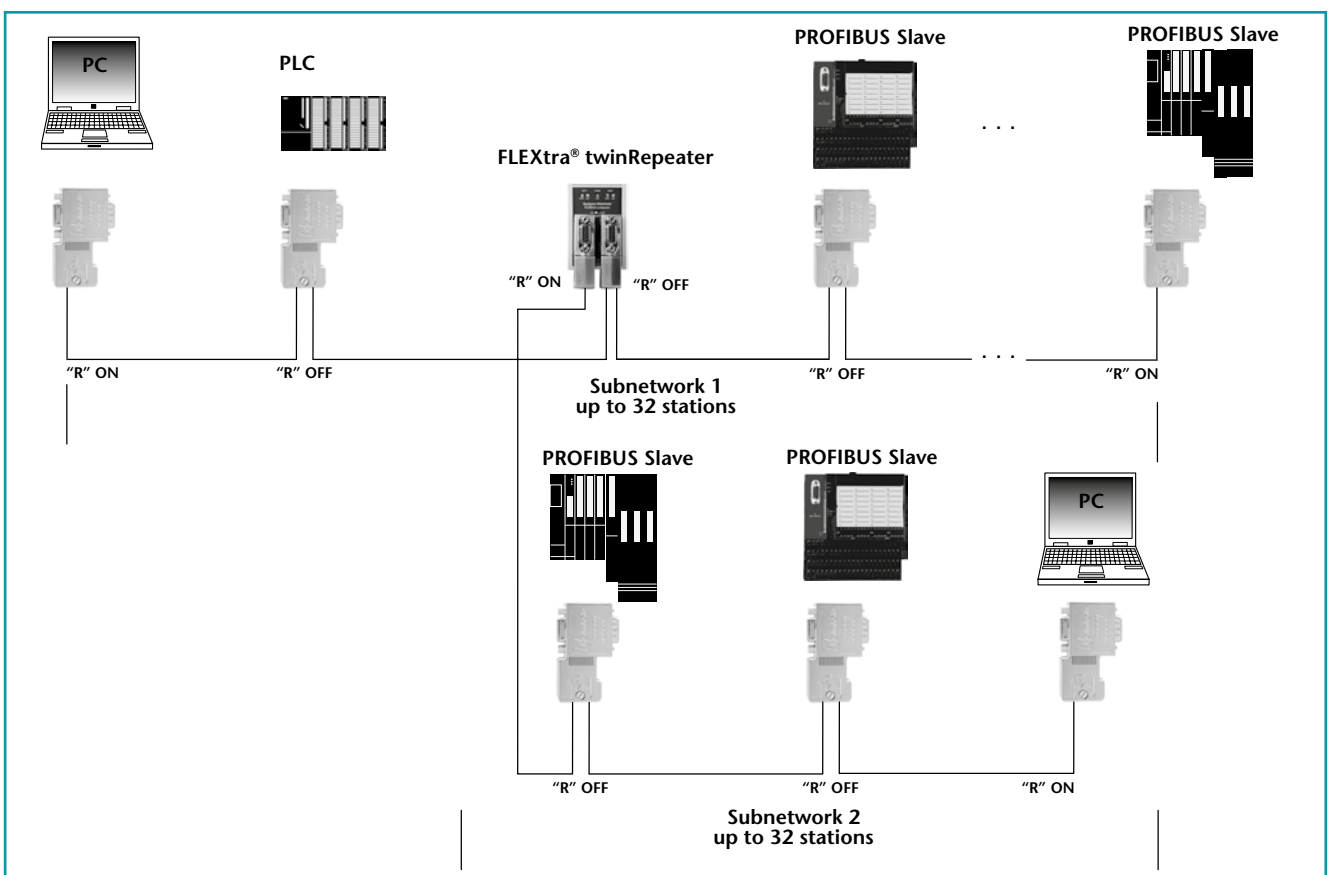

Application example FLEXtra® twinRepeater with spur lines

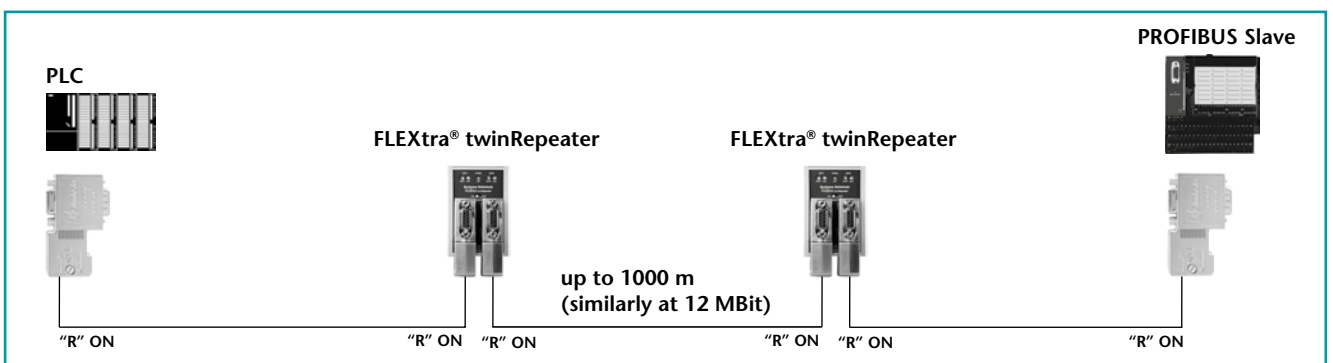

Application example FLEXtra® twinRepeater with long distances

## FLEXtra® multiRepeater 4-way/6-way, PROFIBUS Repeater



FLEXtra® multiRepeater 4-way, 6-way

The new FLEXtra® multiRepeater from Systeme Helmholtz GmbH is a multiple PROFIBUS Repeater. It is designed to be mounted on a DIN rail. The FLEXtra® multiRepeater regenerates the electrical signal arriving on a bus cable and retransmits it (bit reshaping and retransmission).

The level, edge steepness and mark-to-space ratio of the signals are reproduced exactly. It supports transmission rates of 9.6 kbps to 12 Mbps and detects the rate automatically.

The multiRepeater can be used to extend the bus, to increase the number of stations on the bus, and to expand the plant. Use in MPI networks is also possible. As a special application, the FLEXtra® multiRepeater enables a star network with autonomous segments. The status LEDs integrated for each segment provide a fast overview of the bus status.

Moreover, the FLEXtra® multiRepeater ensures electrical isolation between the PROFIBUS segments. The multiRepeater also has a DIP switch for disconnecting individual segments and a switch for disconnecting all segments. The segments are disconnected but each segment remains separately functional. PROFIBUS connectors are required for connection to the PROFIBUS cable.

### Features

- Building star networks
- Plant expansion up to 6 segments with a single device
- Increased number of stations on the bus
- Deployable for bus extension or as a spur line
- Can also be used in MPI networks
- Status LEDs for each segment
- Repeating function can be deactivated for each segment or completely
- Electrical isolation of all segments

## FLEXtra multiRepeater

### Ordering Data

	Order No.
FLEXtra® multiRepeater 4-way (incl. instruction)	700-972-4AA02
FLEXtra® multiRepeater 6-way (incl. instruction)	700-972-6AA02

### Technical Data

	4-way	6-way
Dimensions (D x W x H mm)	35 x 94 x 72	35 x 137 x 72
Weight	Approx. 180 g	Approx. 275 g
Power supply	18 ... 30 VDC	18 ... 30 VDC
Output voltage	5 V, 150 mA per Segment	5 V, 150 mA per Segment
Potential separation	500 V	500 V
Current consumption max.	280 mA	400 mA
Segment connection	Via PROFIBUS Connector	Via PROFIBUS Connector
<b>PROFIBUS interface</b> Transmission rate max.	12 Mbps autodetection	12 Mbps autodetection
Protocol	PROFIBUS-DP to EN 61 158-2	PROFIBUS-DP to EN 61 158-2
Surrounding air temp. Transport and storage temperature	0 °C ... +60 °C -25 °C ... +75 °C	0 °C ... +60 °C -25 °C ... +75 °C
Degree of protection	IP 20	IP 20

FLEXtra® multiRepeater 4-way/6-way, PROFIBUS Repeater

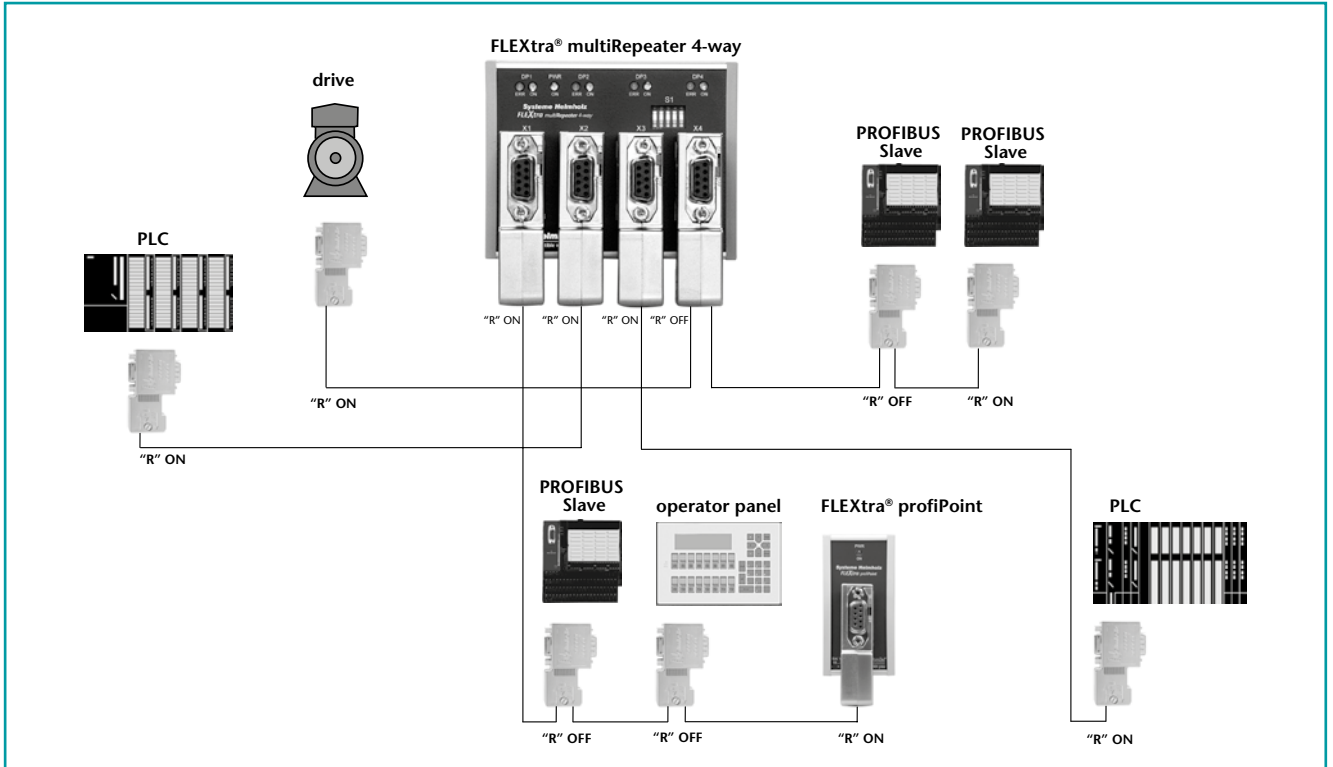

Application example FLEXtra® multiRepeater 4-way

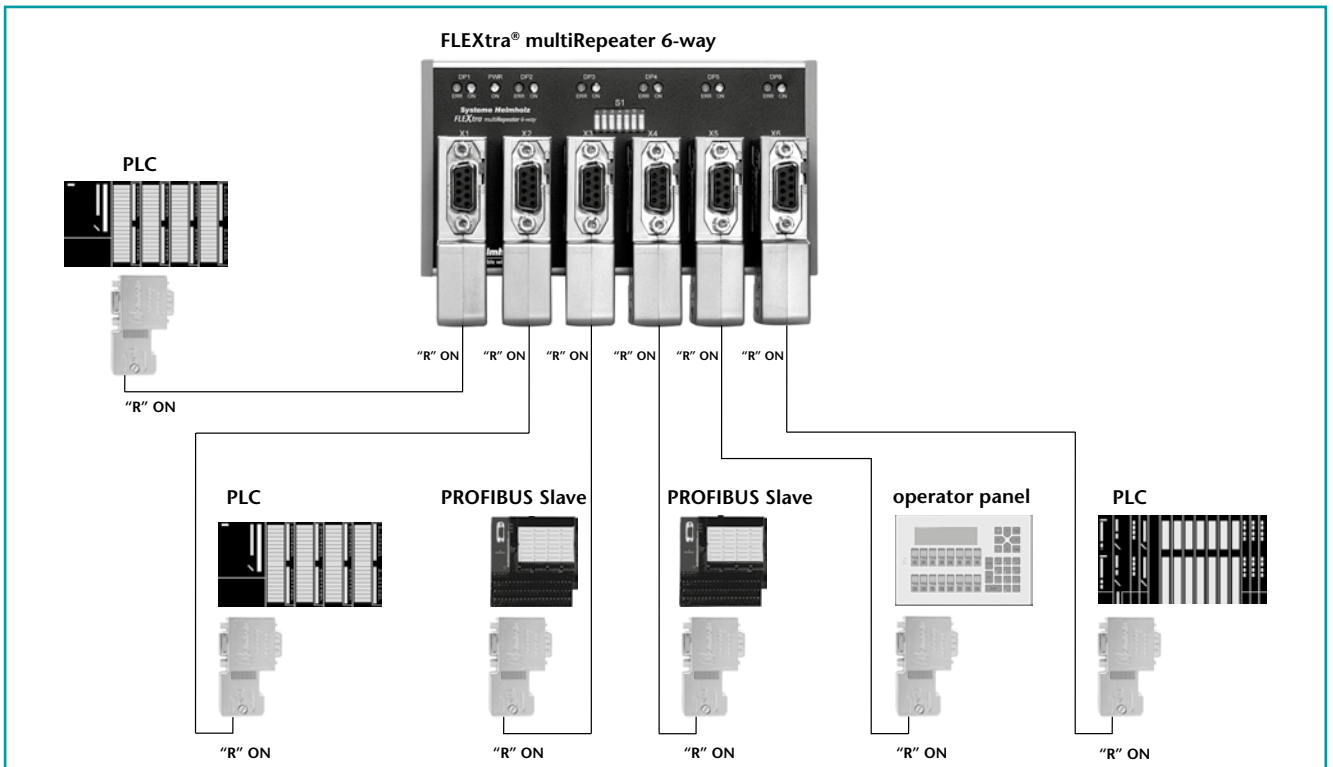

Application example FLEXtra® multiRepeater 6-way

## PROFIBUS Compact Repeater



PROFIBUS Compact Repeater

The new PROFIBUS Compact Repeater from Systeme Helmholtz GmbH is a fully functional PROFIBUS repeater. It is applicable very flexible thanks to its very small style. The repeater covers transmission rates from 9.6 Kbps to 12 Mbps. The transmitted signals are regenerated by the repeater and resent (Bit-Reshaping and Retransmission), so trouble in the line are mostly avoided.

In term of price as well as in term of technical reasons the PROFIBUS Compact Repeater is a real option for multitude applications instead of using standard repeaters.

It can be used for bus extensions (up to 1 km with 2 PROFIBUS Compact Repeaters), increase of the stations as well as for plant extensions.

The operation in MPI networks is also possible.

As a special application option the PROFIBUS Compact Repeater offers you the possibility the usage of drop cables as standalone segments. Therefore it can be plugged directly on the PG port of a built in PROFIBUS connector.

Due to the compact shape no additional room is needed in the cabinet, as the PROFIBUS Compact Repeater can be used instead of PROFIBUS Connector, or simply plugged onto a node in the PROFIBUS Network.

Furthermore no separate power supply is needed, as the PROFIBUS Compact Repeater is using the 5 V power supply, every PROFIBUS device possesses for the terminating resistor. The PROFIBUS Compact Repeater generates an isolation between both PROFIBUS segments. The integrated status LEDs provide a fast overview on the current Bus status.

Ordering Data	
	Order No.
PROFIBUS Compact Repeater (incl. instruction)	700-972-ORB12
Stripping tool for PROFIBUS	700-972-6AA00

### Features

- A real alternative to conventional PROFIBUS repeaters
- No additional space needed in the cabinet
- Very flexible in its use
- Can be used as a bus extension or spur line
- Increases the number of stations on the bus
- System expansion
- Can also be used in MPI networks
- Status LEDs
- 24 V supply is not necessary
- 5 V power supply direct from the PROFIBUS, with that it's usable on every PROFIBUS device
- Electrical isolation



Transmission Rate	max. segment length
9.6 kbps	1000 m
19.2 kbps	1000 m
45.45 kbps	1000 m
93.75 kbps	1000 m
187.5 kbps	1000 m
500 kbps	400 m
1.5 Mbps	200 m
3 Mbps	100 m
6 Mbps	100 m
12 Mbps	100 m

Technical Data	
Dimensions (D x W x H mm)	64 x 40 x 17
Weight	Approx. 40 g
<b>Power supply</b>	
Voltage	+ 5 V DC
Current consumption	typ. 100 mA
Connection	SUB-D, 9-way
<b>PROFIBUS interface</b>	
Transmission rate	max. 9.6 kbps to 12 Mbps autodetection
Protocol	PROFIBUS-DP per EN 50 170
Connection	SUB-D, 9-way
Max. outside diameter	8.0 mm
PROFIBUS cable	60/70 °C copper wire up to 1.0 mm <sup>2</sup>
Connection type	4 terminals
Environmental pollution degree	2
Ambient temperature	0 °C ... +60 °C
Transport and storage temperature	-25 °C ... +75 °C
Degree of protection	IP 20

PROFIBUS Compact Repeater

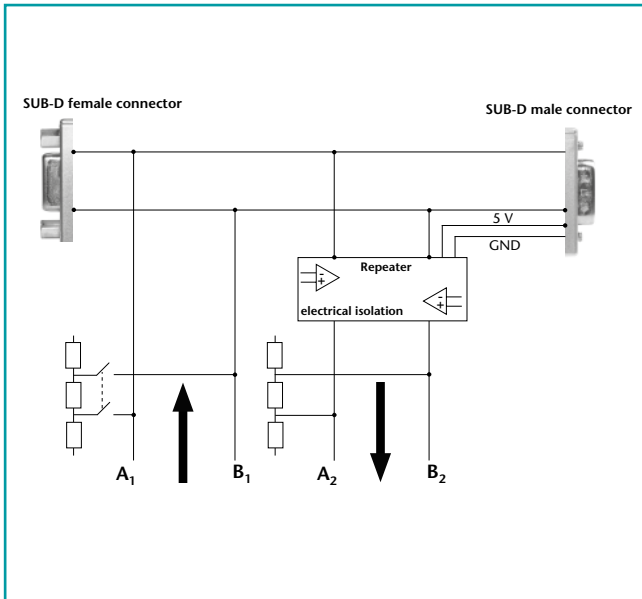

Internal Design

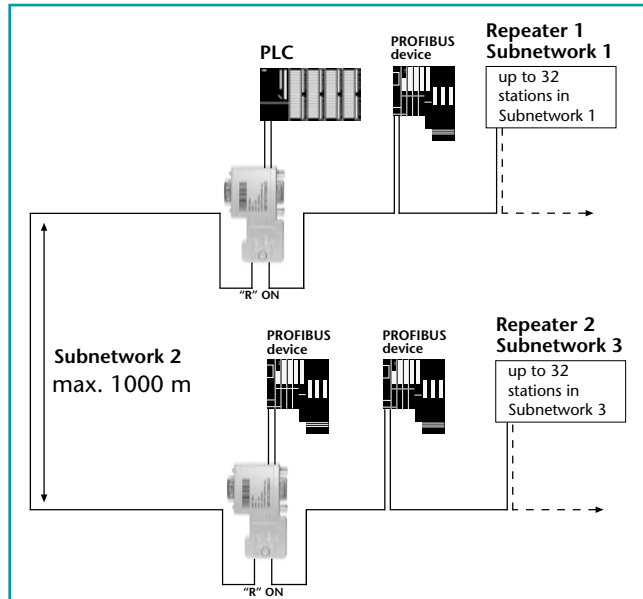

Application example with long distances

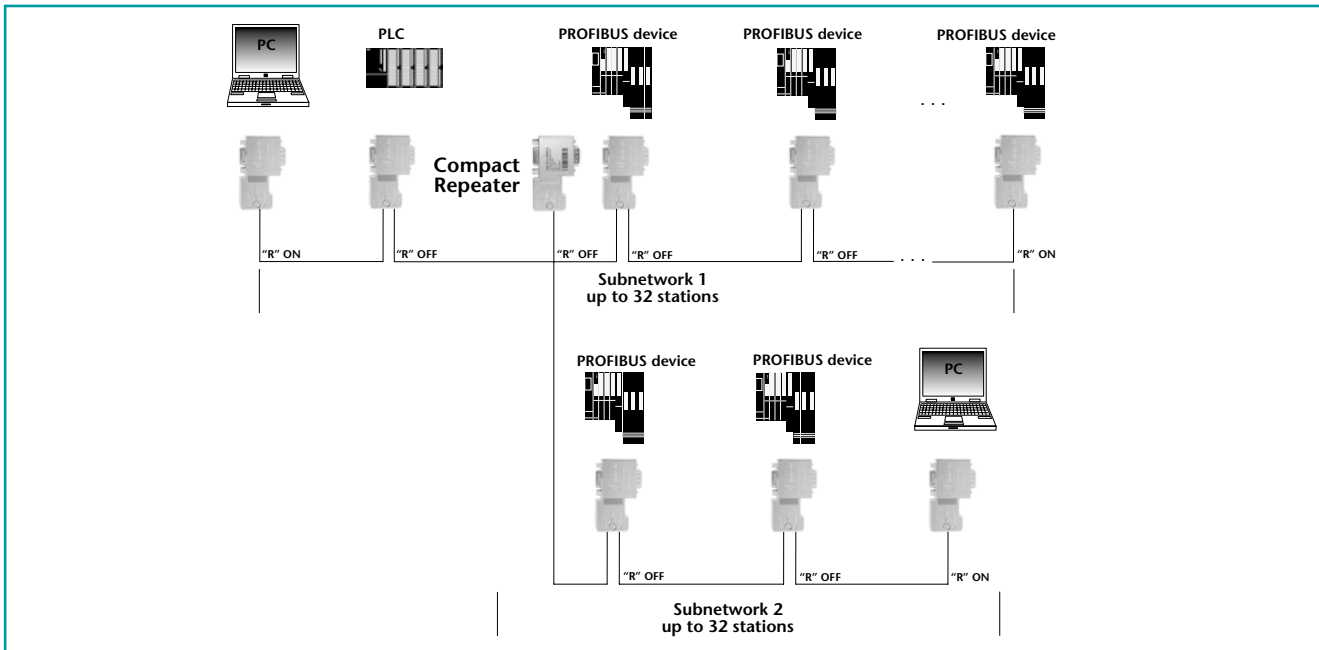

Application example with spur lines

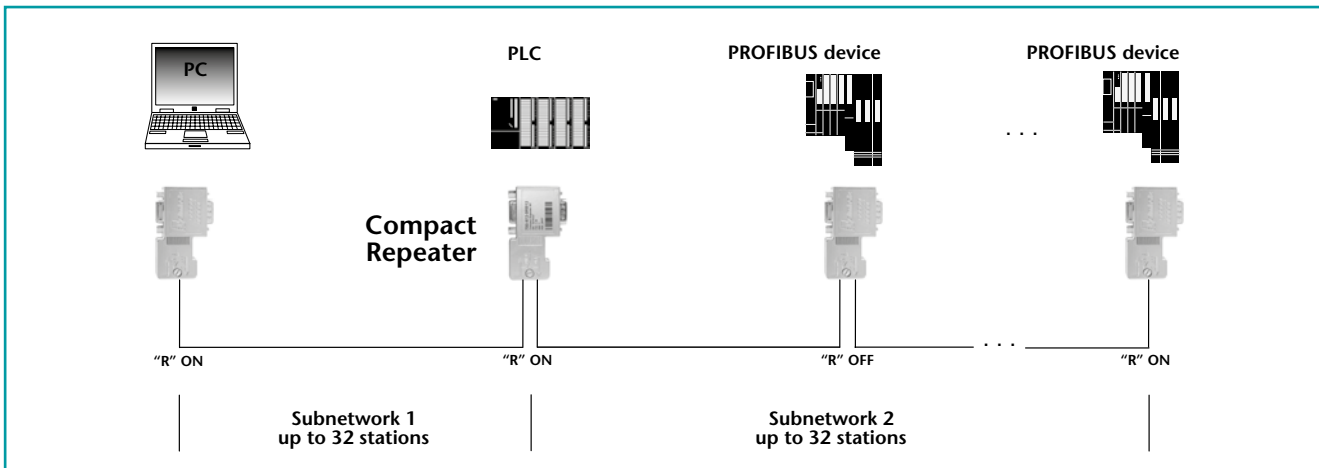

Application example with more than 32 stations

## viBlu, PROFIBUS Radio System



viBlu, PROFIBUS radio system

The PROFIBUS radio system viBlu is a virtual cable that permits the linking of distributed I/Os or intelligent devices (e.g. rotating tables, conveyor systems, etc.) by means of radio.

Data transmission is performed via Bluetooth in the license-exempt 2.4 GHz band and supports the PROFIBUS baud rates of 9.6 kbps to 1.5 Mbps.

Depending on the local circumstances, transmission distances of up to 100 m are possible.

Use of the PROFIBUS radio module is possible in single-master, and in multi-master systems and permits full PROFIBUS expansion. At present, only PROFIBUS-DP-slaves are supported behind a viBlu slave.

The PROFIBUS radio module is powered with 24 V DC from an external power supply.

A 9-way SubD socket is used for the PROFIBUS connection. Moreover, an USB port is integrated to be used for parameterization of the radio link.

5 LEDs on the device provide information about the operating status on the PROFIBUS and on the radio side.

Antennas with a larger gain can optionally be connected to the radio module through an RP-SMA socket on the device to optimize the range.

Outside Europe, use of antennas with a gain of more than 10 dBi is permitted, enabling radio-relay systems with a range, for example, of up to a few kilometers.

### Accessory-Note

For antennas, see page 60.

Ordering Data	
	Order No.
viBlu 100 Master* connection up to 1 Slave; 187.5 kbps	700-761-PFM11
viBlu 100 Slave*	700-761-PFS11
viBlu 200 Master* connection up to 3 Slaves; 1.5 Mbps	700-762-PFM11
viBlu 200 Slave*	700-762-PFS11
*(incl. manual, CD with software)	

1) STEP is a registered trademark of Siemens AG.

### Features viBlu 200

- Settable transmission power
- Up to 3 radio slaves on one radio master
- Bluetooth in the license-exempt 2.4 GHz band
- Up to 1.5 Mbps PROFIBUS-DP
- Simple configuration via USB interface
- No configuration necessary in STEP<sup>1)</sup> 7
- Extensive diagnostics of the radio interface
- Ranges extending to over 100 m

### Features viBlu 100

As for viBlu 200 but with following reservations:

- Only 1 DP-slave
- Only up to 187.5 kbps PROFIBUS-DP

viBlu

Technical Data		
	viBlu 100	viBlu 200
Dimensions (D x W x H mm)	130 x 68 x 30	130 x 68 x 30
Weight	Approx. 170 g	Approx. 170 g
<b>Power supply</b>		
Voltage	DC 24 V (18 ... 30 V)	DC 24 V (18 ... 30 V)
Current consumption	Typ. 100 mA	Typ. 100 mA
<b>PROFIBUS</b>		
Type	RS485, isolated	RS485, isolated
Number of DP/slaves	1 slave	3 slaves
Transmission rate	9.6 kbps ... 187.5 kbps, autodetection	9.6 kbps ... 1.5 Mbps, autodetection
Connection	SUB-D, 9-way	SUB-D, 9-way
<b>Radio interface</b>		
Protocol	Bluetooth	Bluetooth
Range	Up to more than 100 m	Up to more than 100 m
Baud rate	Up to 700 kbps	Up to 700 kbps
Antenna connection	RP-SMA socket	RP-SMA socket
Ambient temperature	0 °C ... 60 °C	0 °C ... 60 °C
Indicators	5 LEDs	5 LEDs
Degree of protection	IP 20	IP 20



viBlu, PROFIBUS Radio System

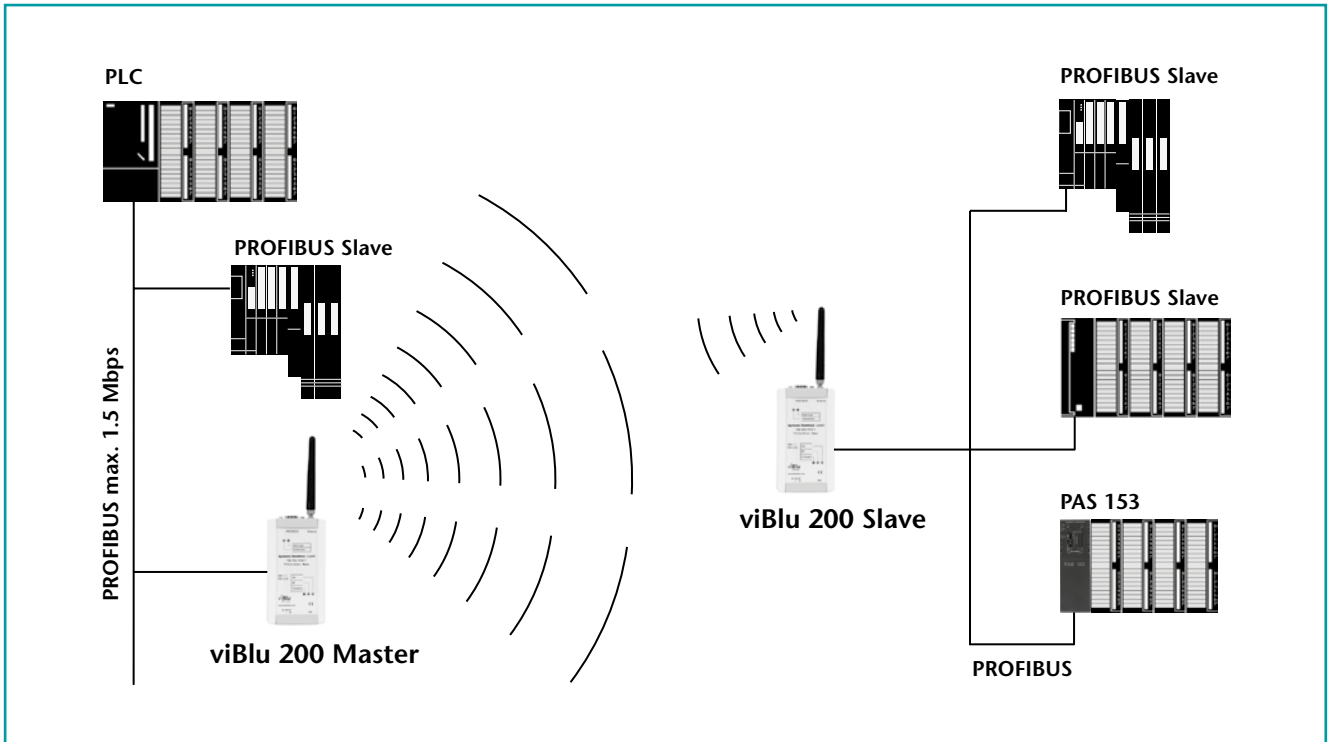

Application example viBlu 200 with a radio slave and up to 3 PROFIBUS-DP stations

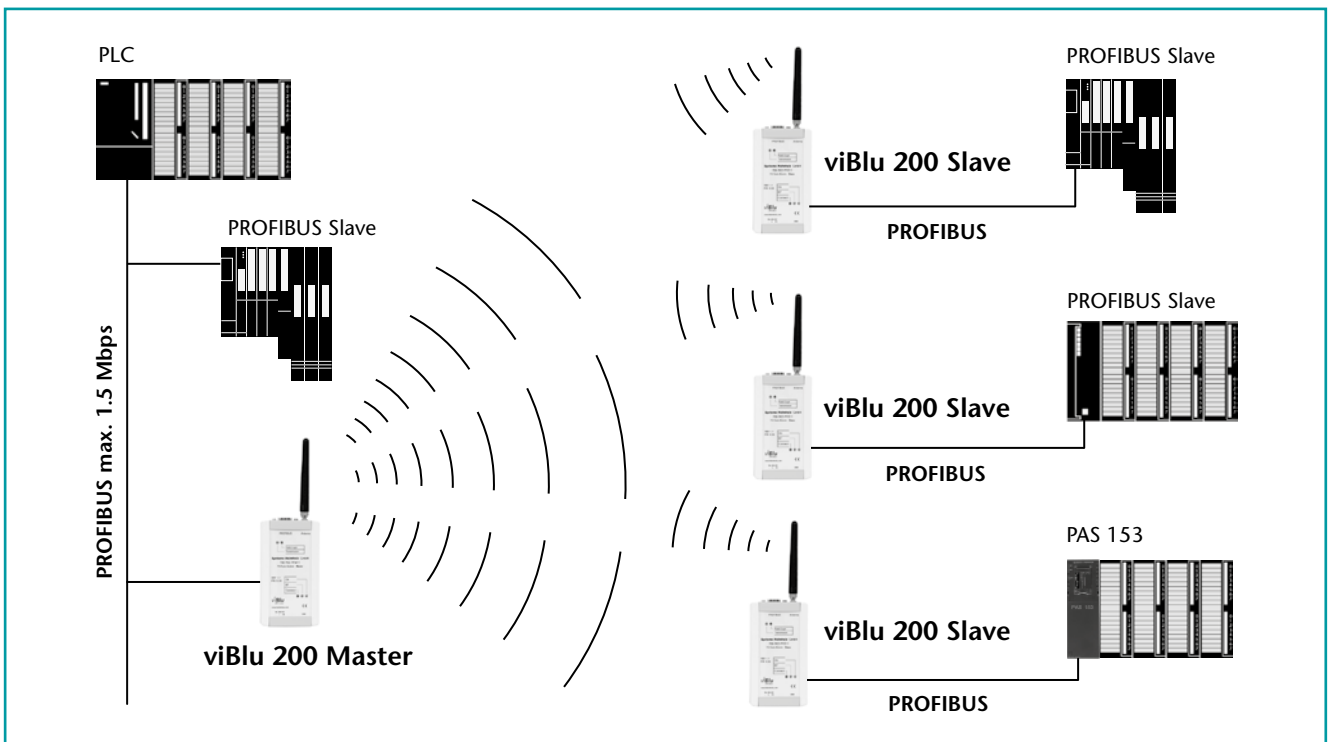

Application example viBlu 200 with 3 radio slaves

## PAS 153 viBlu, distributed PROFIBUS Radio Interface



PAS 153 viBlu, distributed PROFIBUS radio interface

The PAS 153 viBlu distributed PROFIBUS radio interface from Systeme Helmholtz GmbH is for linking digital and analog input and output modules to the PROFIBUS-DP by radio. Data transmission is performed via Bluetooth in the license-exempt 2.4 GHz band and supports the PROFIBUS baud rates of 9.6 kbps to 1.5 Mbps. Depending on the local circumstances, transmission distances of up to 100 m are possible.

Up to 16 modules can be connected to the PAS 153. The PAS 153 viBlu is integrated into the Hardware Configurator of the programming system by a GSD file. The PAS 153 Interface performs all communication between the modular I/O device and the higher-level master unit on the PROFIBUS-DP. The inputs and outputs are assigned to the master in the configuration. Diagnostic information from the modules can be read out via the PAS 153 Interface in the usual way.

The PAS 153 viBlu radio interface supports all input/output modules from Systeme Helmholtz GmbH and numerous modules of the same type from other manufacturers.

The scope of modules supported can be extended at any time by a firmware update via the USB.

Antennas with a larger gain can optionally be connected to the radio module through an RP-SMA socket on the device to optimize the range. Outside Europe, use of antennas with a gain of more than 10 dBi is permitted, enabling radio-relay systems with a range, for example, up to several kilometers.

Moreover, a USB port is integrated to be used for parameterization of the radio link.

6 LEDs on the device provide information about the operating status on the PROFIBUS and on the radio side.

### Accessory-Note

For antennas, see page 60.

Ordering Data	
	Order No.
PAS 153 viBlu 100 (incl. manual, CD with software)	700-763-PFS11
PAS 153 viBlu 200 (incl. manual, CD with software)	700-764-PFS11

### Features PAS 153 viBlu 200

- Up to 16 modules can be plugged in
- Module diagnostics supported
- Can be used on standard Mounting rail
- Any combination of modules is possible (analog/digital)
- GSD file is supplied
- Settable transmission power
- Up to 3 slaves in the radio network
- Bluetooth in the license-exempt 2.4 GHz band
- Up to 1.5 Mbps PROFIBUS-DP
- Simple configuration of the radio parameters through USB
- Extensive diagnostics of the radio interface
- Ranges extending to over 100 m

### Features PAS 153 viBlu 100

As for the PAS 153 viBlu 200, but with the following restrictions:

- Only 1 DP slave in the radio network
- Only up to 187.5 kbps PROFIBUS-DP

Technical Data		
	PAS 153 viBlu 100	PAS 153 viBlu 200
Dimensions in mm (D x W x H)	116 x 40 x 125	116 x 40 x 125
Weight	Approx. 270 g	Approx. 270 g
<b>Power supply</b>		
Voltage	24 V DC (18 ... 30 V)	24 V DC (18 ... 30 V)
Current consumption	Typ. 700 mA	Typ. 700 mA
Output voltage	5 V	5 V
Output current at 5 V DC	max. 1.5 A (for backplane bus)	max. 1.5 A (for backplane bus)
Number of modules	max. 16, including 8 analog	max. 16, including 8 analog
Addressing range	128 bytes for inputs 128 bytes for outputs	128 bytes for inputs 128 bytes for outputs
<b>PROFIBUS</b>	PROFIBUS-DP per EN 50 170	PROFIBUS-DP per EN 50 170
Transmission rate	9.6 kbps to 187.5 kbps, detected automatically	9.6 kbps to 1.5 Mbps, detected automatically
Connection type	SUB D socket, 9-way	SUB D socket, 9-way
<b>Radio interface</b>		
Protocol	Bluetooth	Bluetooth
Number of slaves on the radio network	1 slave	3 slaves
Range	Up to more than 100 m	Up to more than 100 m
Baud rate	Up to 700 kbps	Up to 700 kbps
Antenna connection	RP-SMA socket	RP-SMA socket
Ambient temperature	0 °C ... +60 °C	0 °C ... +60 °C
Transport and storage temperature	-25 °C ... +60 °C	-25 °C ... +60 °C
Displays	6 LEDs	6 LEDs
Degree of protection	IP 20	IP 20

PAS 153 viBlu, distributed PROFIBUS Radio Interface

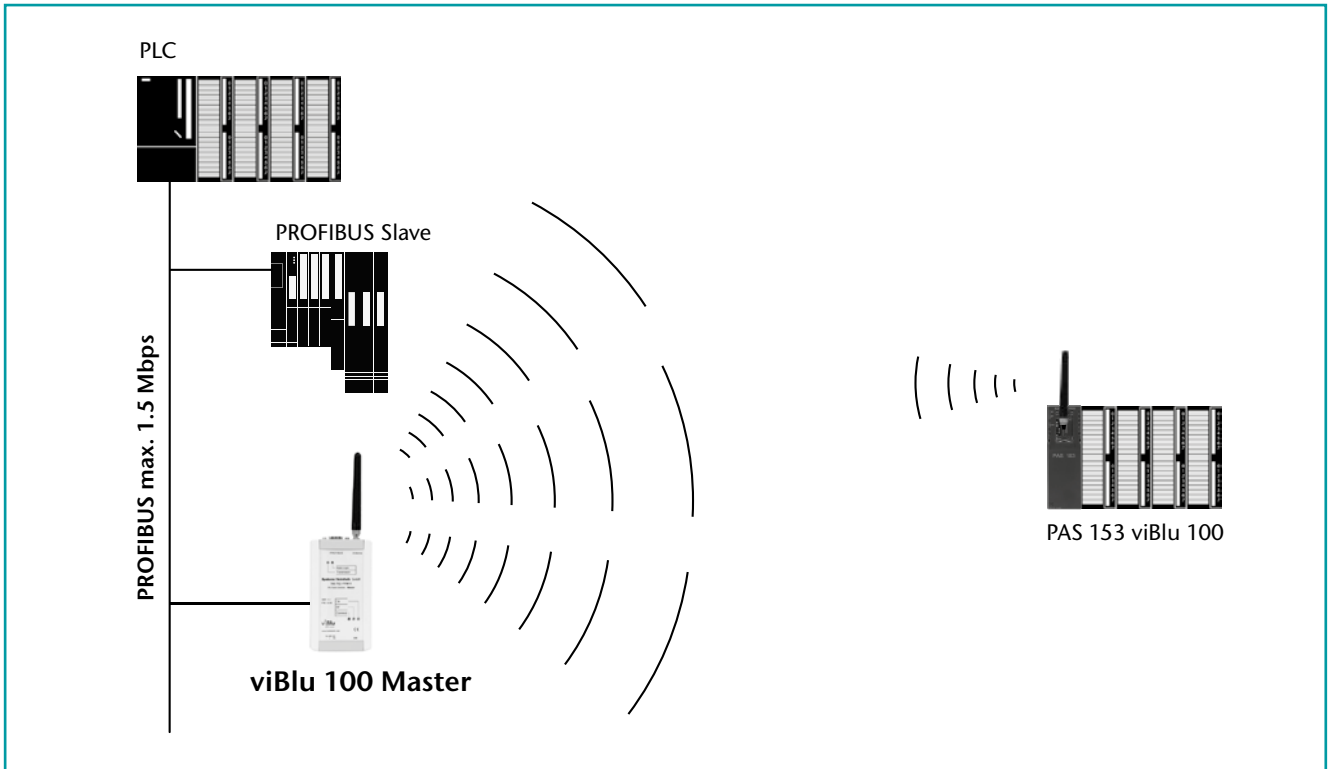

Application example PAS 153 viBlu 100 with 1 Slave

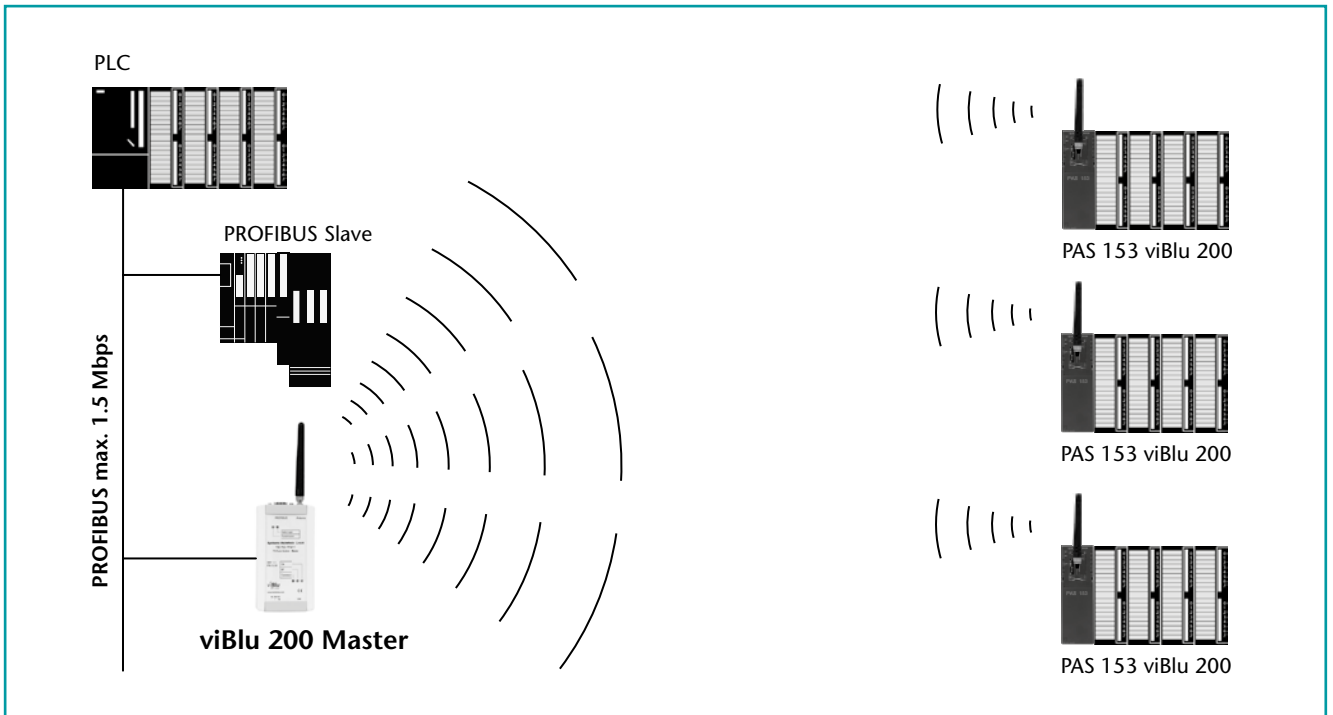

Application example PAS 153 viBlu 200 with 3 Slaves

## Antennas for NETLink® WLAN and viBlu



5 dBi magnetic base antenna

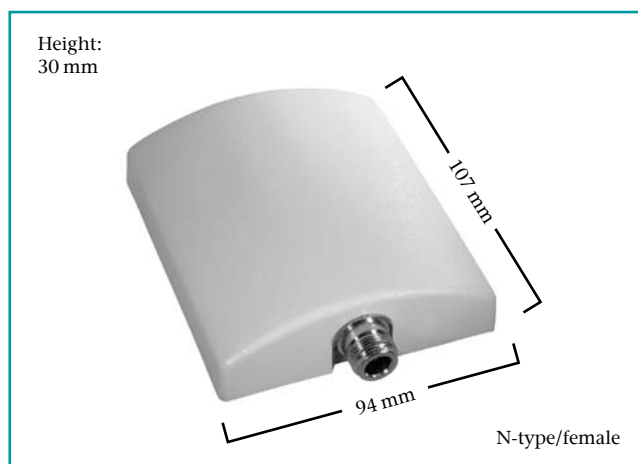

Panel 8 dBi antenna

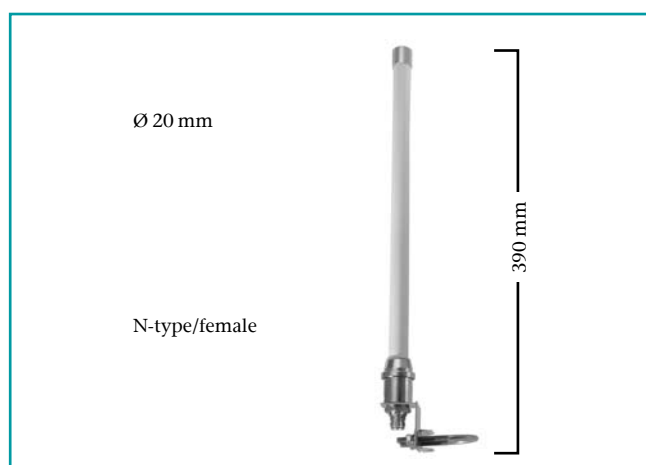

Omni 8 dBi antenna, including wallclamp

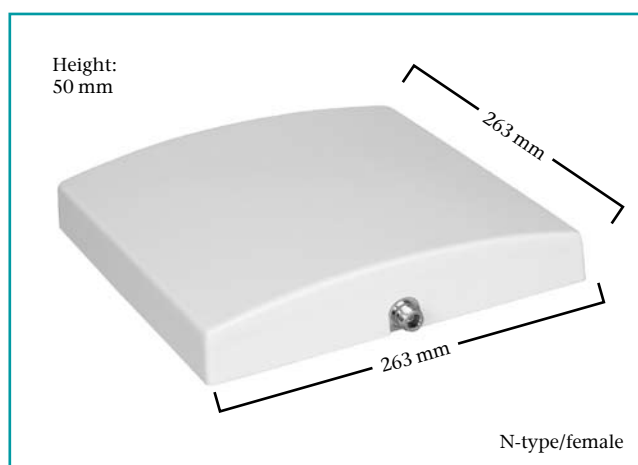

Panel 18 dBi antenna

To optimize the reception power of the NETLink® WLAN and the PROFIBUS radio system viBlu, Systeme Helmholtz GmbH can provide a selection of different antennas. Depending on the design, connecting cables can be procured to match. When planning a radio link, it is important always to note that, both in a mobile and in a stationary installations, the range is to some degree influenced by obstacles and the surrounding structures. Due to the max. transmission power of 100 mW in the 2.4 GHz band, radio links of 10 to 30 meters can be implemented in buildings. Outdoors, 100 to 300 meters can be considered realistic for an unobstructed radio link. With a directed panel antenna, more than 300 meters are possible in optimum conditions.

**Magnetic base antenna 5 dBi**

For mounting on smooth magnetic surfaces. The permanently mounted 1.5 meter long connecting cable further increases the radius of action. The magnetic base can be unscrewed. In this way, the dipole can also be directly operated on the WLAN module and is especially suitable for unobstructed mid-distance links. The omnidirectional antenna can also be correctly aligned with the integrated knee-joint.

**Omnidirectional antenna 8 dBi**

This omniantenna protected by the stable GFK conduit is supplied with mounting brackets to be able to mount it on masts or walls – preferably outdoors. To obtain the best omnidirectional emission properties, there should be no metallic surfaces or obstructions near to the emitting antenna. A cable, available as an accessory, is required for a type N connection.

**Panel antenna 8 dBi (wall mounting) and panel antenna 18 dBi (mast mounting)**

Ideal for use in directional transmission and reception indoors and outdoors. The range and WLAN performance are considerably improved by this design. The appropriate fixtures are supplied. A cable, available as an accessory, is required for a type N connection.

**Ordering Data**

	Order No.
2.4 GHz 5 dBi magnetic base antenna, with 1.5 m antenna cable	700-889-ANT01
2.4 GHz Omni 8 dBi antenna (antenna cable required)	700-889-ANT02
2.4 GHz Panel 8 dBi antenna (antenna cable required)	700-889-ANT03
2.4 GHz Panel 18 dBi antenna (antenna cable required)	700-889-ANT04
2.4 GHz antenna cable, 3 m; 1.7 dB; Ø 5 mm	700-889-ANK01
2.4 GHz antenna cable, 5 m; 2.8 dB; Ø 5 mm	700-889-ANK02
2.4 GHz antenna cable, 6 m; 1.4 dB; Ø 10.3 mm	700-889-ANK03
2.4 GHz antenna cable, 10 m; 2.3 dB; Ø 10.3 mm	700-889-ANK04

## PAS 153, distributed PROFIBUS Interface



PAS 153

The PAS 153 distributed PROFIBUS Interface from Systeme Helmholtz GmbH is for linking digital and analog input and output modules to the PROFIBUS-DP. The module can be mounted on a sectional rail.

Up to 16 modules can be connected to the PAS 153. The PAS 153 is integrated into the hardware configurator of the programming system by a GSD file. The PAS 153 Interface performs all communication between the modular I/O device and the higher-level master unit on the PROFIBUS-DP. The inputs and outputs are assigned to the master in the configuration. Diagnostic information from the modules can be read out via the PAS 153 Interface in the usual way.

The PAS 153 Interface supports all input/output modules from Systeme Helmholtz GmbH and numerous modules of the same type from other manufacturers.

The scope of modules supported can be extended at any time by a firmware update via the USB.

## Features

- DIP switch for setting the PROFIBUS address
- Up to 16 modules can be plugged in
- Module diagnostics supported
- Can be used on standard sectional rail
- Any combination of modules is possible (analog/digital)
- PROFIBUS-DP up to 12 Mbps
- GSD file is supplied
- Firmware update for expanding functions possible via USB

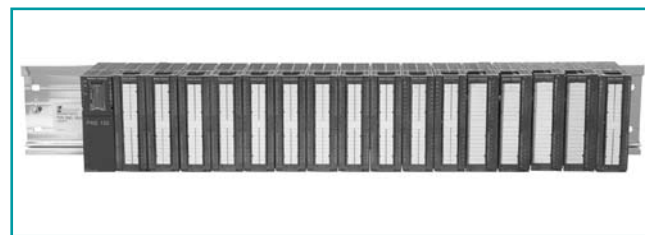

Up to 16 modules can be plugged in



Ordering Data	
	Order No.
PAS 153, distributed PROFIBUS Interface (incl. CD with GSD file)	700-153-1AA03
Manual PAS 153, German/English	900-153-1AA03

Technical Data	
Dimensions (D x W x H mm)	116 x 40 x 125
Weight	Approx. 250 g
<b>Power supply</b>	
Voltage	DC 24 V
Current consumption	max. 625 mA
Output voltage	DC 5 V
Output current at DC 5 V	max. 1.5 A (to backplane)
<b>PROFIBUS Interface</b>	
Transmission rate	max. 12 Mbps, autodetection
Protocol	PROFIBUS-DP to EN 50 170
Addressrange	128 Bytes for inputs 128 Bytes for outputs
Module count	max. 16.8 of these analog
Connection	Male, SUB-D, 9-way
Ambient temperature	0 °C ... +60 °C
Transport and storage temperature	-25 °C ... +60 °C

## DP/DP Coupler



DP/DP Coupler

The DP/DP coupler interlinks two PROFIBUS-DP networks and permits data transmission between the masters and the two DP networks. The maximum size of the transmitted data is 244 Bytes of input data and 244 Bytes of output data. The DP/DP coupler is configured in the S7 software or by means of a GSD file.

### Features

- Up to 244 Bytes of input data and 244 Bytes of output data can be exchanged between two PROFIBUS networks
- Dual-redundant power supply
- Electrical isolation between the PROFIBUS networks
- PROFIBUS addresses can be set by DIL switch or software
- PROFIBUS-DP up to 12 Mbps

Technical Data	
Dimensions (D x W x H mm)	116 x 40 x 125
Weight	Approx. 250 g
<b>Power Supply</b> Nominal power supply Current consumption	24 V DC (20.4 V... 28.8 V) Approx. 150 mA at DC 24 V
<b>Electric isolation of the 24 V power supply</b> To PROFIBUS-DP	Yes
Mutually	Yes
<b>PROFIBUS interface</b> Transmission rate	9.6 ... 12 Mbps
Protocol	PROFIBUS-DP
Telegram length I/O data	Max. 244 Bytes inputs/ 244 Bytes outputs
Ambient temperature	0 °C ... 60 °C
Degree of protection	IP 20

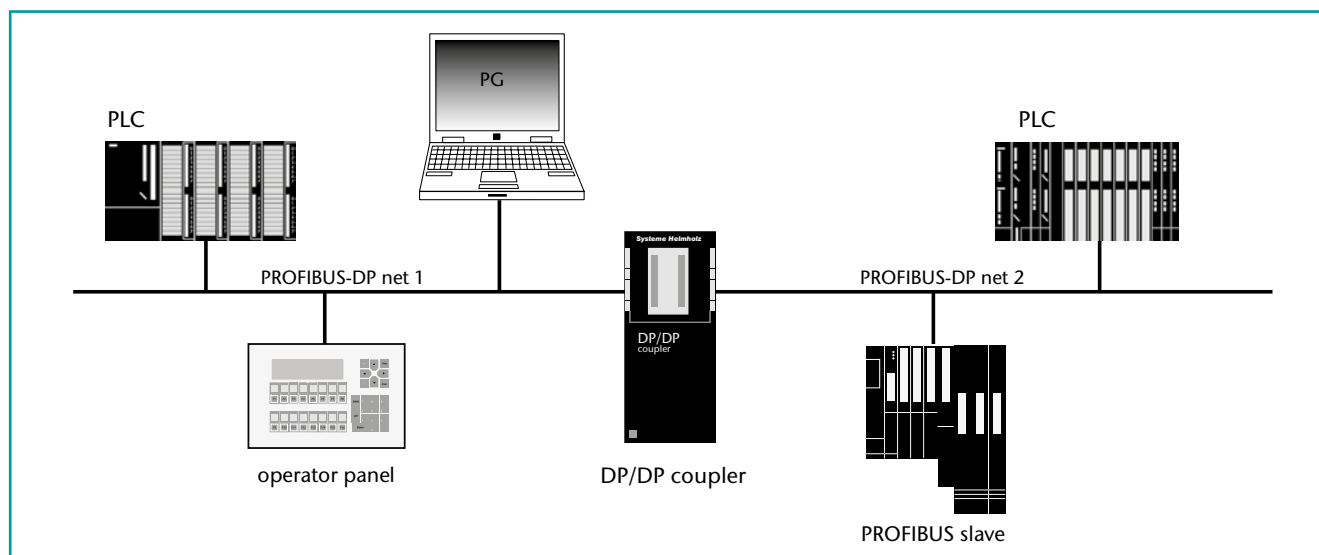

Application example DP/DP Coupler

### Ordering Data

	Order No.
DP/DP Coupler (incl. manual)	700-158-0AD01
Mounting rail adapter for DIN rail (optional)	700-390-6BA01
Mounting rail 40 mm	700-390-1XA04

## FLEXtra® profiPoint, active Termination and Measuring Point



FLEXtra® profiPoint

### Features

- Power supply independent of bus stations
- Bus termination independent of terminal device due to autonomous power supply
- Can be used as an active measuring point
- Supply to active PROFIBUS components (Compact Repeater, NETLink®, PROFIBUS diagnostic connector)

**FLEXtra** profiPoint

The new FLEXtra® profiPoint from Systeme Helmholz GmbH is primarily used for supplying power to the terminating resistor and is designed for mounting on a DIN rail. It can be used in combination with a PROFIBUS connector as an active measuring point or as an active termination. The electric power is supplied independently of the bus stations via a connection socket. If used as an active terminating resistor, bus system stations can be coupled and decoupled randomly without faults occurring. The correct function of the FLEXtra® profiPoint can be read from an integrated LED. A PROFIBUS connector is required for connection to the PROFIBUS cable (also available as a set).

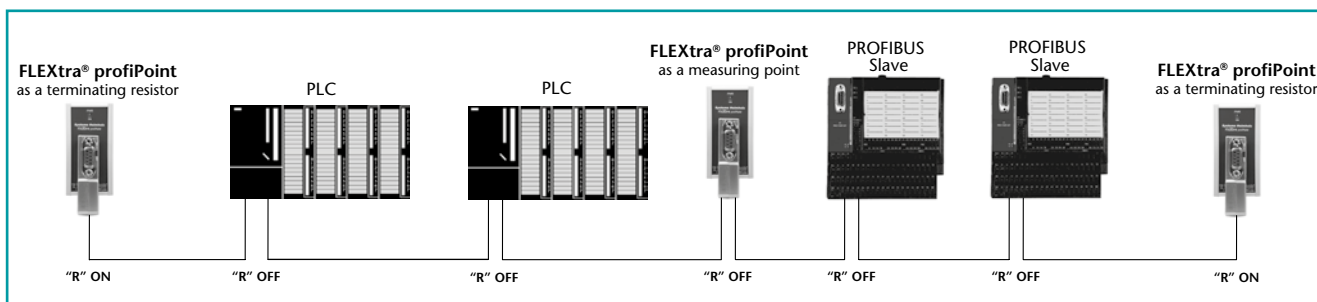

Application example FLEXtra® profiPoint

Ordering Data	
	<b>Order No.</b>
<b>FLEXtra® profiPoint</b> (incl. instruction)	700-972-1AA02
<b>FLEXtra® profiPoint Set</b> FLEXtra® profiPoint, PROFIBUS connector screw terminals 90° diagnostic LEDs with PG (incl. instruction)	700-972-1XA02

Technical Data	
Dimensions (D x W x H mm)	35 x 32 x 72
Weight	Approx. 85 g
Power supply	18 ... 30 VDC
Output voltage	24 VDC/5 VDC
Potential separation	500 V
Current consumption	max. 400 mA
Segment connection	Via PROFIBUS connector
Ambient temperature	0 °C ... +60 °C
Transport and storage temperature	-25 °C ... +75 °C
Degree of protection	IP 20

## Active PROFIBUS Dropcable



Dropcable PROFIBUS for PG

The active PROFIBUS dropcable from the Systeme Helmholtz GmbH is used for a failure-free connection of a programming device to an existing PROFIBUS net. The active cable doesn't represent a spur line because of its integrated electronics.

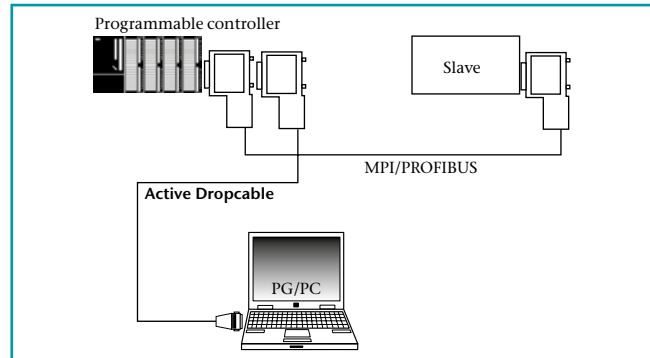

Application example Active Dropcable



Ordering Data	
	Order No.
Dropcable PROFIBUS for PG with 90° PROFIBUS connector, 3 m (incl. instruction)	700-901-4BD00
Dropcable PROFIBUS for PG with 35° PROFIBUS connector, 3 m (incl. instruction)	700-901-4BD10

Technical Data	
Dimensions (length)	3 m
Weight	Approx. 260 g
Power supply	DC 5 V
Current consumption	max. 100 mA at 5V
<b>PROFIBUS interface</b>	
Transmission	max. 12 Mbps
Connection	SUB-D, 9-way
Ambient temperature	0 °C ... +60 °C
Transport and storage temperature	-25 °C ... +75 °C
Degree of protection	IP 20





# NETLink® Gateways

Ethernet Gateways  
WLAN Gateways  
Highspeed USB Gateways  
for MPI/PPI/PROFIBUS

## NETLink® PRO Compact, PROFIBUS-Ethernet Gateway

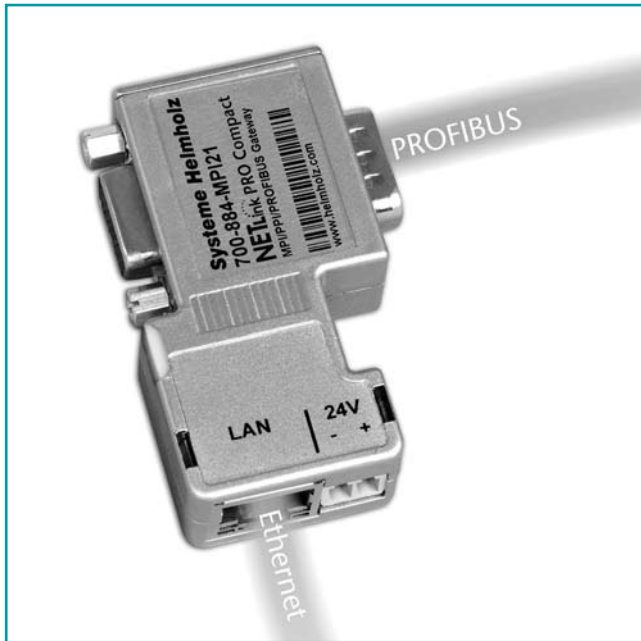

NETLink® PRO Compact, PROFIBUS-Ethernet Gateway

### • Now with diagnostic function in the web interface

NETLink® PRO Compact offers flexibility, compact design and even more features than its predecessor. It may be connected to any MPI/PROFIBUS interface of the bus system. The second PG socket permits connection to further devices. Power is supplied via the CPU of the automation device or optionally by an external 24 V DC. The network interface can be used with every standard Cat-5 cable, thus, cable lengths up to 100 meters are possible without any further components. NETLink® PRO Compact permits conversion from TCP/IP to MPI/PPI/PROFIBUS with the full transmission rate of up to 12 Mbps with max. 32 simultaneous links. The baud rate is detected automatically and the Single-Master function supports the communication with passive participants. The supplied driver automatically embeds in the S7 Engineering Tools. Furthermore, the widely used ISO on TCP (RFC 1006) protocol is active. Therefore, the integration of SCADA, HMI and OPC applications can be realized very easily. The integrated web interface provides even more parameterization- and security functions. Furthermore, you can perform diagnostics and configurations with the supplied SHTools software. A free download of the latest SHTools version is available on our website [www.helmholz.com](http://www.helmholz.com). Thus, additional functions can be updated at every time on your own.

### Features

- RFC 1006 (ISO on TCP)
- CPU-to-CPU communication
- Power supply from the CPU or alternatively via external 24 V DC
- Support for all common S7 Engineering Tools
- Dynamic address assignment with DHCP
- Security functions for securing TCP/IP access
- Additional CPU write protection
- For S7-200<sup>1)</sup>, S7-300<sup>1)</sup>, S7-400<sup>1)</sup>
- Up to 16 TCP connections
- Up to 32 links on MPI/PROFIBUS
- Simple configuration via the web interface
- Variable monitoring in the browser window
- Support of slave parameterization
- Electrical isolation to the MPI/PPI/PROFIBUS
- MPI/PPI/PROFIBUS from 9.6 kbps up to 12 Mbps

## NETLink PRO Compact

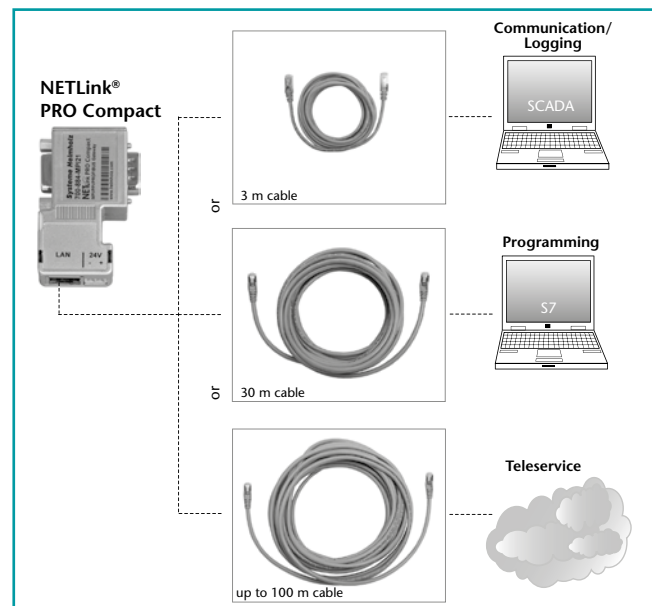

Application example NETLink® PRO Compact

### Ordering Data

	Order No.
NETLink® PRO Compact (incl. 3 m Ethernet cable, Quick Start Guide, CD with software and manual)	700-884-MPI21
Manual NETLink® PRO Compact, German/English	900-884-MPI21

1) S7-200, S7-300 and S7-400 are registered trademarks of Siemens AG.



Observe variables in the web interface

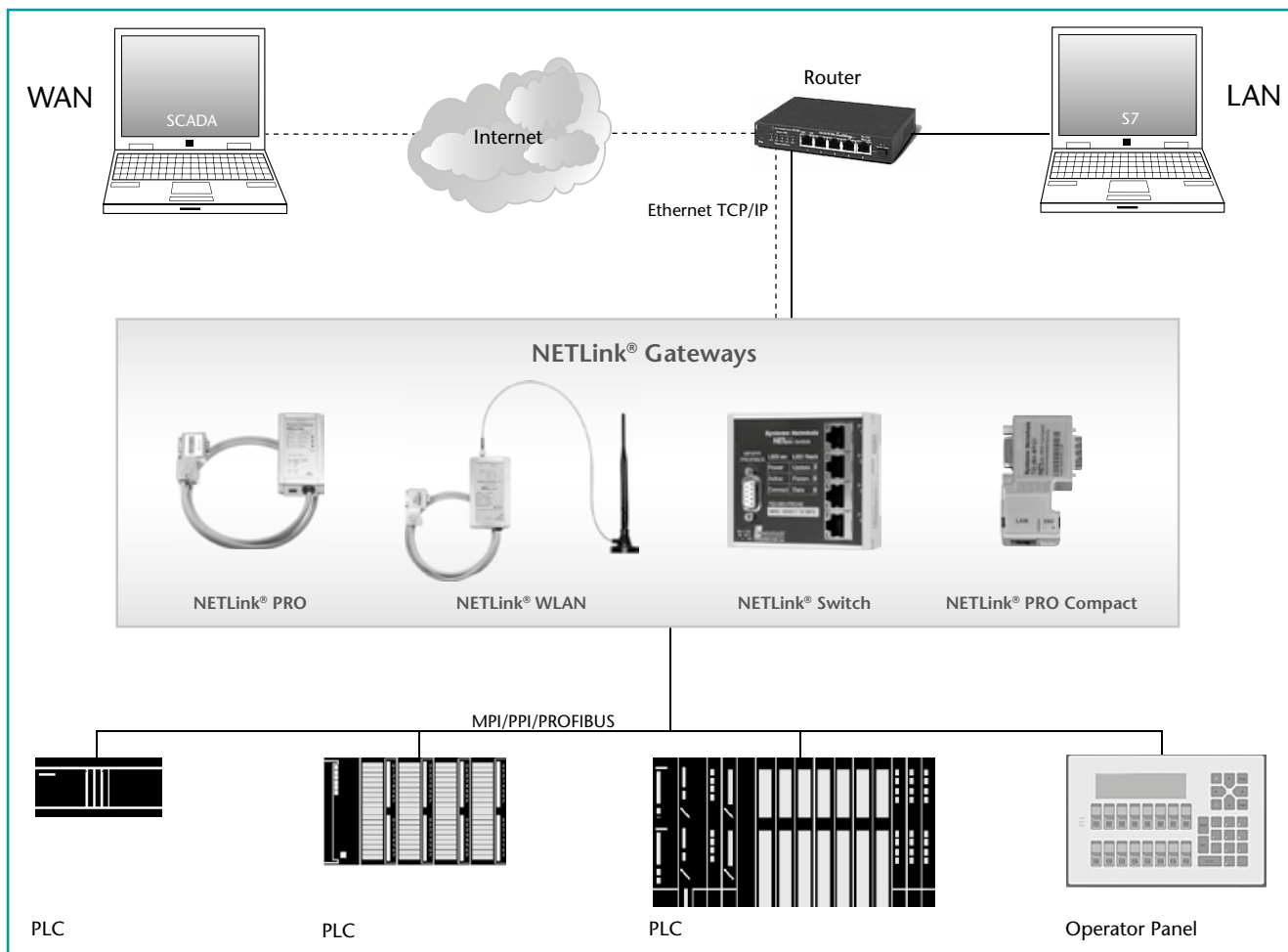

Application Example LAN-WAN connection via ISO on TCP

Technical Data	
Dimensions (D x W x H mm)	64 x 40 x 17
Weight	Approx. 110 g
<b>Power Supply</b>	
Voltage	DC 24 V ±25%
Current consumption max.	200 mA
<b>Communication interface</b>	
Type	10 Base-T 100 Base-TX
Connector	RJ45
Transmission rate	10/100 Mbps, autodetection
<b>MPI/PPI/PROFIBUS</b>	
Type	RS485, isolated
Transmission rate max.	12 Mbps, autodetection
Connector	SUB-D, 9-way with PG interface and repeater
Protocols	FDL frames, RFC 1006
Ambient temperature	0 °C ... 60 °C
Indicators	2 LEDs, therefrom one three coloured (for general status information)
Degree of protection	IP 20

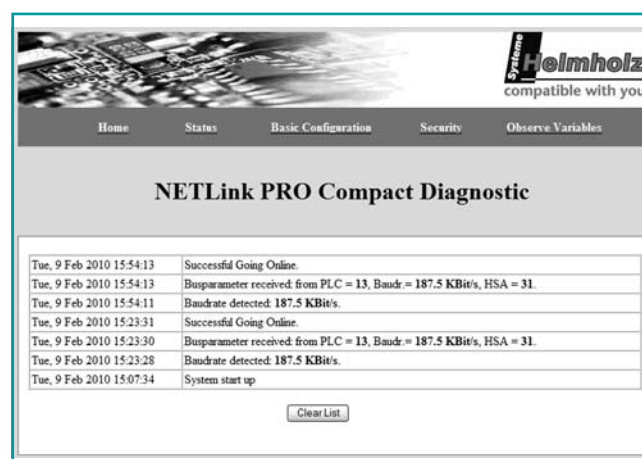

Quick diagnostic information about bus activities in the Web Interface

## NETLink® PRO, Ethernet Gateway for MPI/PROFIBUS



NETLink® PRO, Ethernet Gateway

### • The classic for communication via LAN and WAN

NETLink® PRO for programming, projecting and visualization of Siemens S7 PLCs is placed directly on the interface of the CPU. The cable is designed as active line and thus represents no influence on the MPI / PROFIBUS. At the controller end, the NETLink® PRO supports the full transmission speed up to 12 Mbps. The bus connector is equipped with a PG socket and allows the connection of other devices.

A 3 m Ethernet cable is included. On the Ethernet side, the NETLink® PRO can be applied in the LAN and the WAN (to be used, for example, via VPN).

The baud rate is detected automatically and the communication to further passive participants on the bus is possible. The supplied driver automatically embeds in the S7 Engineering Tools. Furthermore, the widely used ISO on TCP (RFC 1006) protocol is supported. Therefore, the integration of SCADA, HMI and OPC applications can be realized very easily.

The integrated web interface provides even more parameterization- and security functions. Furthermore, you can perform diagnostics and configurations with the supplied SHTools software. A free download of the latest SHTools version is available on our website [www.helmholz.com](http://www.helmholz.com). Thus, additional functions can be updated at any time by yourself.

Ordering Data	
	Order No.
<b>NETLink® PRO</b> (incl. 3 m Ethernet cable, Quick Start Guide, CD with software and manual)	700-881-MPI11
<b>NETLink® PRO, 35° cable outlet for S7-400<sup>1)</sup></b> (incl. 3 m Ethernet cable, Quick Start Guide, CD with software and manual)	700-881-MPI12
<b>DIN rail adapter short</b> <b>Power Plug (optional)</b>	700-751-HSH01 700-751-SNT01
<b>Manual NETLink® PRO,</b> German/English	900-881-MPI11

1) S7-200, S7-300 and S7-400 are registered trademarks of Siemens AG.

### Features

- RFC 1006 (ISO on TCP)
- Power supply from the CPU or alternatively via external 24 V DC
- Support for all common S7 Engineering Tools
- Dynamic address assignment with DHCP
- Security functions for securing TCP/IP access
- For S7-200<sup>1)</sup>, S7-300<sup>1)</sup>, S7-400<sup>1)</sup>
- Up to 6 TCP connections
- Up to 12 links on MPI/PROFIBUS
- Simple configuration via the web interface
- Variable monitoring in the browser window
- Support of slave parameterization
- Electrical isolation to the MPI/PPI/PROFIBUS
- MPI/PPI/PROFIBUS from 9.6 kbps up to 12 Mbps
- Create your own visualizations with NETLink® WebService by using HTML

## NETLink PRO

Technical Data	
Dimensions (D x W x H mm)	102 x 54 x 30
Weight	Approx. 180 g
<b>Power Supply</b>	
Voltage	DC 24 V ±25 %
Current consumption	max. 150 mA
<b>Communication interface</b>	
Type	10 Base-T 100 Base-TX
Connector	RJ45
Transmission rate	10/100 Mbps, autodetection
<b>MPI/PPI/PROFIBUS</b>	
Type	RS485, isolated
Transmission rate	max. 12 Mbps, autodetection
Connector	SUB-D, 9-way with PG interface and repeater
Protocols	FDL frames, RFC 1006
Ambient temperature	0 °C ... 60 °C
Indicators	3 LEDs, therefrom 2 two coloured
Degree of protection	IP 20

## NETLink® Switch, Ethernet Gateway with integrated 4-port Switch



NETLink® Switch

### • Programming – Visualization – data acquisition and switching over Ethernet

The NETLink® Switch is an Ethernet Gateway with integrated 4 port store-and-forward switch for programming on S7-200<sup>1)</sup>, S7-300<sup>1)</sup> and S7-400<sup>1)</sup> PLCs. It is intended for mounting on a DIN rail bracket. Either it is integrated in the bus with a PROFIBUS connector or plugged directly with an active drop cable onto the MPI/PPI or PROFIBUS interface of a bus subscriber.

The NETLink® Switch is powered from an external 24 V DC power source. At the controller end, the NETLink® Switch permits the full transmission speed of 12 Mbps with maximum 32 simultaneous connections via MPI or PROFIBUS.

The baud rate is detected automatically and a Single-Master function enables communication to passive participants. The supplied driver automatically embeds in the S7 Engineering Tools. Furthermore, NETLink® Switch supports widely used ISO on TCP (RFC 1006) protocol. Therefore, the integration of SCADA, HMI and OPC applications can be realized very easily. The integrated web interface provides even more parameterization- and security functions. Besides the gateway function the integrated 4 port 10Base-T/100Base-TX switch can be used to integrate additional Ethernet subscribers. Furthermore, you can perform diagnostics and configurations with the supplied SHTools software.

A free download of the latest SHTools version is available on our website [www.helmholz.com](http://www.helmholz.com). Thus, additional functions can be updated at any time by yourself.

Ordering Data	
	Order No.
<b>NETLink® Switch</b> (incl. 3 m Ethernet cable, Quick Start Guide, CD with software and manual)	700-883-PRO42
<b>Manual NETLink® Switch,</b> German/English	900-883-PRO42

1) S7-200, S7-300, S7-400 and Simatic are registered trademarks of Siemens AG.

### Features

- RFC 1006 (ISO on TCP)
- CPU-to-CPU communication
- Support for all common S7 Engineering Tools
- Dynamic address assignment with DHCP
- Security functions for securing TCP/IP access
- Additional CPU write protection
- For S7-200<sup>1)</sup>, S7-300<sup>1)</sup>, S7-400<sup>1)</sup>
- Up to 16 TCP connections
- Up to 32 links on MPI/PROFIBUS
- Simple configuration via the web interface
- Clear diagnostic page in the web interface
- Variable monitoring in the browser window
- Support of slave parameterization
- Electrical isolation to the MPI/PPI/PROFIBUS
- MPI/PPI/PROFIBUS from 9.6 kbps up to 12 Mbps
- Create your own visualization with NETLink® WebService by using HTML

## NETLink Switch

Technical Data	
Dimensions (D x W x H mm)	35 x 83 x 72
Weight	Approx. 180 g
<b>Power Supply</b>	
Voltage	DC 24 V
Current consumption	approx. 120 mA
<b>Communication interfaces</b>	
Type	10 Base-T 100 Base-TX
Connectors	RJ45
Transmission rate	10/100 Mbps, autodetection
<b>Switch</b>	
Ports	4
Features	Autonegotiation, Autoplunk, Flow Control, MDI/MDI-X Auto Crossover, Spanning Tree
Switching method	Store and forward
<b>MPI/PPI/PROFIBUS</b>	
Type	RS485, isolated
Transmission rate	max. 12 Mbps, autodetection
Connector	SUB-D, 9-way
Protocols	FDL frames, RFC 1006
Ambient temperature	0 °C ... 60 °C
Indicators	3 LEDs, therefrom 2 two coloured
Degree of protection	IP 20

## NETLink® WLAN, PROFIBUS Ethernet WLAN Gateway



NETLink® WLAN

### • Flexible wireless programming using Ad Hoc or Infrastructure mode

The NETLink® WLAN is an Ethernet Gateway with integrated WLAN (Wi-Fi) interface for programming on S7-200<sup>1)</sup>, S7-300<sup>1)</sup> and S7-400<sup>1)</sup> PLCs. The bus connector (with PG socket) is plugged directly onto the MPI or PROFIBUS interface of the CPU. The NETLink® WLAN can optionally be powered from an external 24 V DC power source. At the controller end, the NETLink® WLAN permits the full transmission speed of 12 Mbps with max. 32 simultaneous connections via MPI or PROFIBUS.

The baud rate is detected automatically and the Single-Master function supports the communication to passive participants. The supplied driver automatically embeds in the S7 Engineering Tools. Furthermore, widely used ISO on TCP (RFC 1006) protocol is supported. Therefore, the integration of SCADA, HMI and OPC applications can be realized very easily.

An integrated web interface provides even more parameterization and security functions. Besides the RJ45 socket, the WLAN interface (802.11 b/g) can be connected with up to 54 Mbps. This can be parameterized via the web interface for “ad hoc” or “infrastructure” mode. All standard Wireless Security methods such as: WEP, WPA and WPA2 are supported. Furthermore, you can perform diagnostics and configurations with the supplied SHTools software.

A free download of the latest SHTools version is available on our website [www.helmholz.com](http://www.helmholz.com). Thus, additional functions can be updated at any time by yourself.

Ordering Data	
	Order No.
NETLink® WLAN (incl. 3 m Ethernet cable, Quick Start Guide, CD with software and manual)	700-882-MPI21
DIN rail adapter long Power Plug (optional)	700-751-HSH10 700-751-SNT01
Manual NETLink® WLAN, German/English	900-882-MPI21

1) S7-200, S7-300, S7-400 are registered trademarks of Siemens AG.

### Features

- RFC 1006 (ISO on TCP)
- CPU-to-CPU communication
- Support for all common S7 Engineering Tools
- Dynamic address assignment with DHCP
- Security functions for securing TCP/IP access
- Additional CPU write protection
- For S7-200<sup>1)</sup>, S7-300<sup>1)</sup>, S7-400<sup>1)</sup>
- Up to 16 TCP connections
- Up to 32 links on MPI/PROFIBUS
- Simple configuration via the web interface
- Clear diagnostic page in the web interface
- Variable monitoring in the browser window
- Support of slave parameterization
- Electrical isolation to the MPI/PPI/PROFIBUS
- MPI/PPI/PROFIBUS from 9.6 kbps up to 12 Mbps
- Create your own visualization with NETLink® WebService by using HTML

## NETLink WLAN

Technical Data	
Dimensions (D x W x H mm)	130 x 68 x 30
Weight	Approx. 280 g
<b>Power Supply</b>	
Voltage	DC 24 V ±25 %
Current consumption typ.	200 mA
<b>Communication interface</b>	
Type	10 Base-T 100 Base-TX
Connector	RJ45
Transmission rate	10/100 Mbps, autodetection
<b>WLAN Specifications</b>	
Type	IEEE 802.11b; 802.11g
Frequency Range	2.412 - 2.484 GHz
Output Power	14 dBm + 1.5 dBm/-1.0 dBm
Data Rates	54 Mbps
Security	WEP, WPA, WPA2
<b>MPI/PPI/PROFIBUS</b>	
Type	RS485, isolated
Transmission rate max.	12 Mbps, autodetection
Connector	SUB-D, 9-way with PG interface and repeater
Protocols	FDL frames, RFC 1006
Ambient temperature	0°C ... 60°C
Indicators	5 LEDs, therefrom 2 two coloured
Degree of protection	IP 20

## Antennas for NETLink® WLAN and viBlu



5 dBi magnetic base antenna

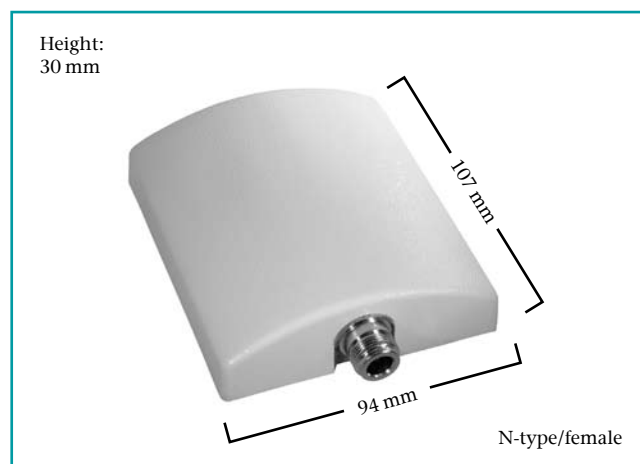

Panel 8 dBi antenna

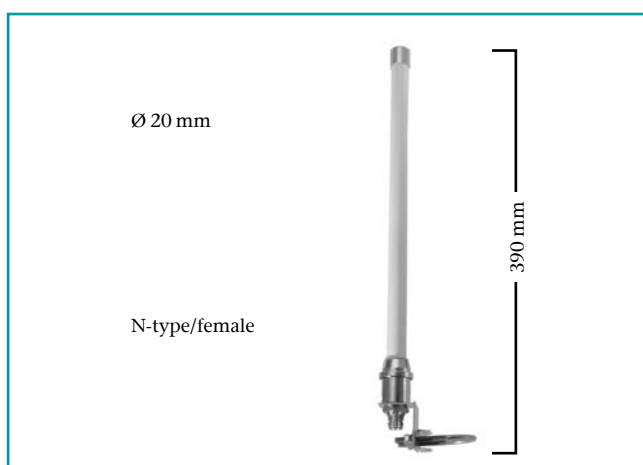

Omni 8 dBi antenna, including wallclamp

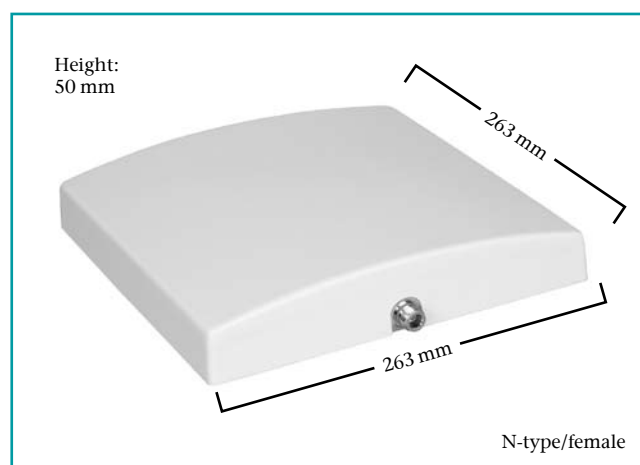

Panel 18 dBi antenna

To optimize the reception power of the NETLink® WLAN and the PROFIBUS radio system viBlu, Systeme Helmholtz GmbH can provide a selection of different antennas. Depending on the design, connecting cables can be procured to match. When planning a radio link, it is important always to note that, both in a mobile and in a stationary installations, the range is to some degree influenced by obstacles and the surrounding structures. Due to the max. transmission power of 100 mW in the 2.4 GHz band, radio links of 10 to 30 meters can be implemented in buildings. Outdoors, 100 to 300 meters can be considered realistic for an unobstructed radio link. With a directed panel antenna, more than 300 meters are possible in optimum conditions.

**Magnetic base antenna 5 dBi**

For mounting on smooth magnetic surfaces. The permanently mounted 1.5 meter long connecting cable further increases the radius of action. The magnetic base can be unscrewed. In this way, the dipole can also be directly operated on the WLAN module and is especially suitable for unobstructed mid-distance links. The omnidirectional antenna can also be correctly aligned with the integrated knee-joint.

**Omnidirectional antenna 8 dBi**

This omni antenna protected by the stable GFK conduit is supplied with mounting brackets to be able to mount it on masts or walls – preferably outdoors. To obtain the best omnidirectional emission properties, there should be no metallic surfaces or obstructions near to the emitting antenna. A cable, available as an accessory, is required for a type N connection.

**Panel antenna 8 dBi (wall mounting) and panel antenna 18 dBi (mast mounting)**

Ideal for use in directional transmission and reception indoors and outdoors. The range and WLAN performance are considerably improved by this design. The appropriate fixtures are supplied. A cable, available as an accessory, is required for a type N connection.

**Ordering Data**

	Order No.
2.4 GHz 5 dBi magnetic base antenna, with 1.5 m antenna cable	700-889-ANT01
2.4 GHz Omni 8 dBi antenna (antenna cable required)	700-889-ANT02
2.4 GHz Panel 8 dBi antenna (antenna cable required)	700-889-ANT03
2.4 GHz Panel 18 dBi antenna (antenna cable required)	700-889-ANT04
2.4 GHz antenna cable, 3 m; 1.7 dB; Ø 5 mm	700-889-ANK01
2.4 GHz antenna cable, 5 m; 2.8 dB; Ø 5 mm	700-889-ANK02
2.4 GHz antenna cable, 6 m; 1.4 dB; Ø 10.3 mm	700-889-ANK03
2.4 GHz antenna cable, 10 m; 2.3 dB; Ø 10.3 mm	700-889-ANK04

## What is NETLink® WebService?

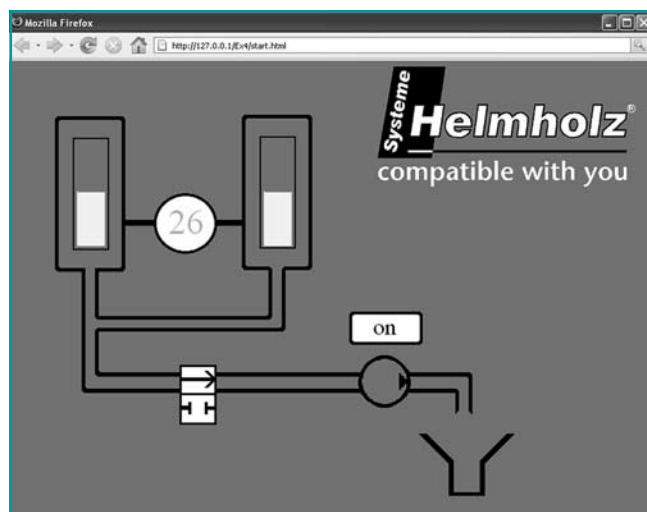

Example of NETLink® WebService visualization

## NETLink WebService

NETLink® WebService is a service to help you create your own browser interface for simple visualization tasks. Operand values from your PLC can be visualized for monitoring services via a NETLink® Ethernet device (except of NETLink® PRO Compact). The program modules required for this are available free of charge. Using application examples and the configuration tool, changes in value can be visualized in a few steps.

Using Java-Script functions status images can be integrated, which, for example, indicate fill levels of tanks or valve positions in the visualization.

Furthermore, the values from a NETLink® Ethernet gateway can be adapted for display by means of stored arithmetic operations. If you release your scripts to a web host, they can be accessed from any internet computer. This means that machine states can be called up from any location.

The examples supplied by Systeme Helmholz GmbH can be freely edited. However, HTML and Java Script programming knowledge is required to expand your own user interfaces.

## What is CPU-to-CPU communication?

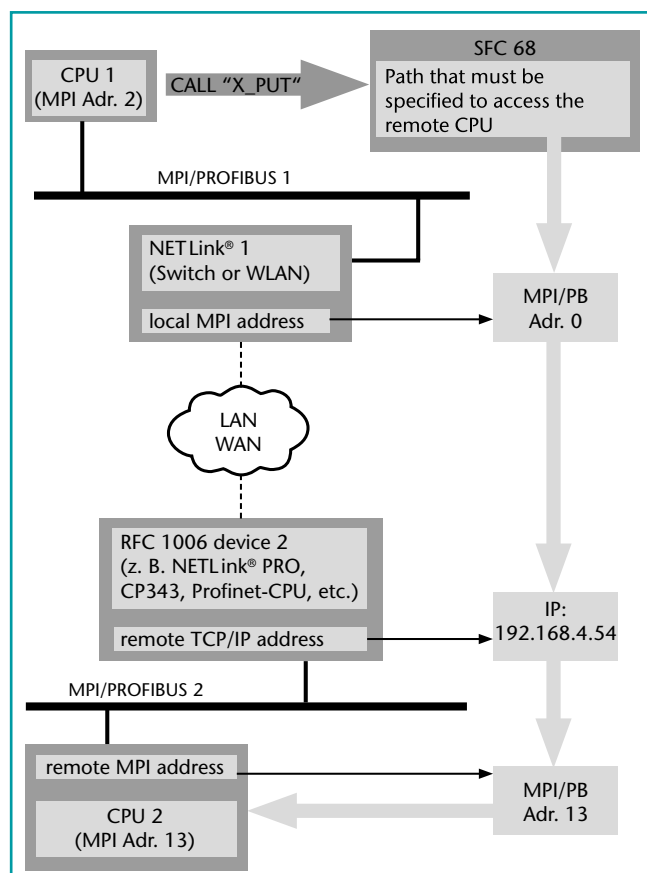

Implement a CPU-to-CPU link using the S7 basic communication. The connection types MPI and PROFIBUS are supported on all S7-300<sup>1)</sup> and S7-400<sup>1)</sup> PLCs. Siemens S7 software features simple functions (SFCs) for the transmission of data between two stations. All NETLink® Ethernet gateways (NETLink® PRO just passive) of the Systeme Helmholz GmbH support this S7 mechanisms X\_PUT and X\_GET (read and write data from/to a communicating partner outside the local S7 station). For this type of client-server communication, the familiar RFC1006 transport protocol (ISO on top of TCP) is used. This enables use of CP's or Profinet CPU's that support this protocol as clients.

The connections are not configured but are explicitly established during the SFC call. For that reason, a connection resource is only permanently assigned for the communication at the "active" end. The "passive" end responds to the queries of the active partner and therefore only requires a resource if it establishes a connection.

This has the advantage that function calls only need to be stored at the active end (server).

If the intention is to expand an already configured X\_PUT/X\_GET process via TCP/IP, it is only necessary to include an additional X\_PUT (with the parameters for the remote station - see illustration) in the program execution to open the communication channel via a NETLink® Ethernet gateway.

The number of useful data items that can be transmitted per communication request is up to 76 bytes for the entire system. For support with configuration (including newcomers), Systeme Helmholz GmbH provides simple example projects for the STEP<sup>1)</sup> 7 programming software free of charge. Using the associated application description, the CPU-to-CPU communication can be implemented in just a few steps.

1) S7-200, S7-300, S7-400, Simatic and STEP are registered trademarks of Siemens AG.



## NETLink® USB Compact, mini PROFIBUS USB Gateway



NETLink® USB Compact, mini PROFIBUS USB Gateway

### • The mobile plug and play programming adapter

NETLink® USB Compact offers flexibility and compact design with the advantages of plug and play via USB. It may be connected to any MPI/PROFIBUS interface of the bus system. The second PG socket permits connection of further devices. The connection with the PC is established using the integrated 3 m high-speed USB cable.

The NETLink® USB Compact is supplied with power from the USB bus. At the USB end, the protocols Fullspeed (12 Mbps) and Highspeed (480 Mbps) are supported. The NETLink® USB Compact permits conversion of a USB interface to MPI/PROFIBUS for programming or visualization with the full transmission rate of up to 12 Mbps with max. 32 simultaneous links.

Baud rate is detected automatically and a Single-Master function enables the communication with passive participants. The supplied driver automatically embeds in the S7 Engineering Tools. The MPI/PROFIBUS is electrically isolated from the USB interface (functional isolation). Furthermore, you can perform diagnostics and configurations with the supplied SHTools software.

A free download of the latest SHTools version is available on our website [www.helmholz.com](http://www.helmholz.com). Thus, additional functions can be updated at any time by yourself.

Ordering Data	
	Order No.
NETLink® USB Compact (incl. Quick Start Guide, CD with software and manual)	700-892-MPI21
Manual NETLink® USB Compact, German/English	900-892-MPI21

1) S7-200, S7-300 and S7-400 are registered trademarks of Siemens AG.

### Features

- Support for all common S7 Engineering Tools
- For S7-200<sup>1)</sup>, S7-300<sup>1)</sup>, S7-400<sup>1)</sup>
- Up to 32 links on MPI/PROFIBUS
- Support of slave parameterization
- Electrical isolation to the MPI/PPI/PROFIBUS
- MPI/PPI/PROFIBUS from 9.6 kbps up to 12 Mbps
- USB 2.0 up to 480 Mbps (Highspeed)
- No separate power supply required
- With programming device connector (PG) as standard

## NETLink USB Compact

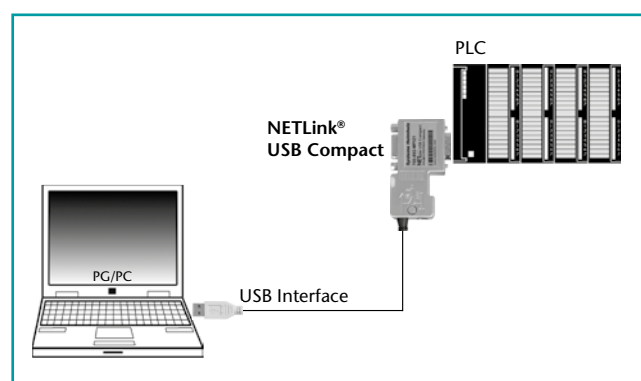

Application Example NETLink® USB Compact

Technical Data	
Dimensions (D x W x H mm)	64x 40 x 17
Weight	Approx. 115 g
<b>Power Supply</b>	
Voltage	DC 5 V USB
Current consumption	typ. 200 mA at DC 5 V USB
<b>Communication interface</b>	
Type	USB 2.0
Connector	USB-A-female connector
Transmission rate	12 Mbps Fullspeed/ 480 Mbps Highspeed
<b>MPI/PPI/PROFIBUS</b>	
Type	RS485, isolated
Transmission rate	max. 12 Mbps, autodetection
Connector	SUB-D, 9-way with PG interface
Protocols	FDL frames
Ambient temperature	0 °C ... 60 °C
Indicators	2 LEDs, therefrom one three coloured (for general status information)
Degree of protection	IP 20

## NETLink® USB, Highspeed USB Gateway for MPI/PROFIBUS



NETLink® USB, Highspeed USB Gateway

### Features

- Support for all common S7 Engineering Tools
- For S7-200<sup>1)</sup>, S7-300<sup>1)</sup>, S7-400<sup>1)</sup>
- Up to 12 links on MPI/PROFIBUS
- Support of slave parameterization
- Electrical isolation to the MPI/PPI/PROFIBUS
- MPI/PPI/PROFIBUS from 9.6 kbps up to 12 Mbps
- USB 2.0 up to 480 Mbps (Highspeed)
- Power supply via USB or external 24 V power source possible
- With programming device connector (PG) as standard

## NETLink USB

### • The plug and play classic for communication via USB

The NETLink® USB for programming, projecting and visualization of Siemens S7 PLCs may be connected to any MPI/PROFIBUS interface of the bus system.

NETLink® USB is powered from the USB bus, but also features an optional 24 V DC power supply. The cable connection is 1.2 m long and is designed as active line and thus represents no influence on the MPI/PROFIBUS. The integrated PG socket permits connection of further devices. The connection to the PC is established with the included 3-m-high-speed USB cable. NETLink® USB allows full transmission speed up to 12 Mbps to MPI/PPI and PROFIBUS.

Baud rate is detected automatically and communication to further passive participants on the bus is possible. At the USB end the protocols Fullspeed (12 Mbps) and Highspeed (480 Mbps) are supported. The supplied driver automatically embeds in the Simatic<sup>1)</sup> Engineering Tools. The MPI/PPI/PROFIBUS is electrically isolated from the external 24 V DC power source and from the USB interface (functional separation). Furthermore, you can perform diagnostics and configurations with the supplied SHTools software.

A free download of the latest SHTools version is available on our website [www.helmholz.com](http://www.helmholz.com). Thus, additional functions can be updated at any time by yourself.

Ordering Data	
	Order No.
NETLink® USB (incl. 3 m USB cable, Quick Start Guide, CD with software and manual)	700-890-MPI11
DIN rail adapter short Power Plug (optional)	700-751-HSH01 700-751-SNT01
Manual NETLink® USB, German/English	900-890-MPI11

1) S7-200, S7-300, S7-400 and Simatic are registered trademarks of Siemens AG.

Technical Data	
Dimensions (D x W x H mm)	102 x 54 x 30
Weight	Approx. 180 g
<b>Power Supply</b>	
Voltage	DC 24 V ±25 % DC 5 V USB, automatically selected
Current consumption	max. 150 mA at DC 24 V/ max. 500 mA at DC 5 V USB
<b>Communication interface</b>	
Type	USB 2.0
Connector	USB-B female connector
Transmission rate	12 Mbps (Fullspeed)/ 480 Mbps (Highspeed)
<b>MPI/PPI/PROFIBUS</b>	
Type	RS485, isolated
Transmission rate	max. 12 Mbps, autodetection
Connector	SUB-D, 9-way with PG interface and terminating resistor
Protocols	FDL frames
Ambient temperature	0 °C ... 60 °C
Indicators	3 LEDs, therefrom 2 two coloured
Degree of protection	IP 20

## NETLink® SLOT USB, Highspeed USB Gateway as a plug-in board

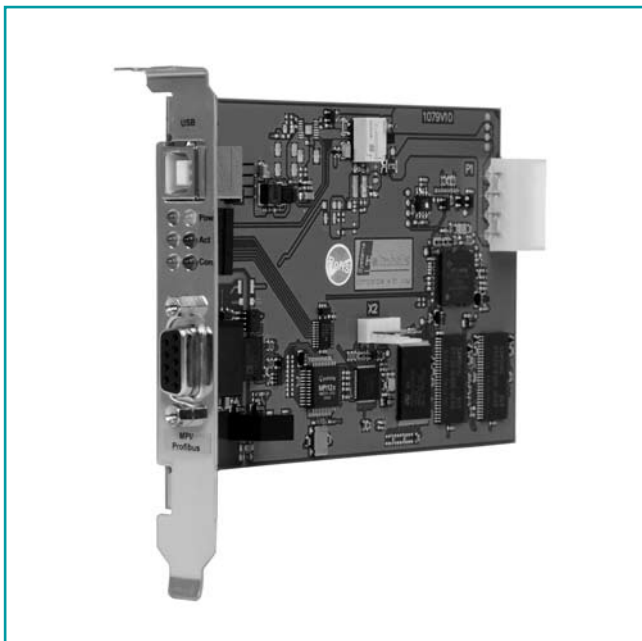

NETLink® SLOT USB

- Plug-in card for standard programming PCs, industrial PCs, operator panel PCs, etc.
- No connection to the PCI bus of the motherboard

The NETLink® SLOT USB is an alternative to a PROFIBUS-CP plug-in board and is directly installed in the computer. It is connected to the programmable controller by means of a standard PROFIBUS connection.

Connection to the USB bus is possible directly from the motherboard using the cable supplied. The necessary 5 volts are also provided through this connection. Moreover, a direct connection from the computer power supply unit can be used for the power supply. As an alternative, complete connection of the NETLink® SLOT USB is also possible through an external USB cable. The NETLink® SLOT USB features automatic baud rate detection and supports the USB protocols Fullspeed (12 Mbps) and Highspeed (480 Mbps). The NETLink® SLOT USB permits programming or visualization from a USB interface on up to 32 simultaneous MPI/PPI/PROFIBUS connections with the full transmission rate of 12 Mbps.

The baud rate is detected automatically and the Single-Master function supports the communication with passive participants. The supplied driver automatically embeds in the S7 Engineering Tools. The MPI/PPI/PROFIBUS is electrically isolated from the PC power supply and from the USB interface (functional isolation). Furthermore, you can perform diagnostics and configurations with the supplied SHTools software.

A free download of the latest SHTools version is available on our website [www.helmholz.com](http://www.helmholz.com). Thus, additional functions can be updated at any time by yourself.

## Ordering Data

	Order No.
<b>NETLink® SLOT USB</b> (incl. Quick Start Guide, CD with software and manual)	<b>700-891-MPI21</b>
<b>Manual NETLink® SLOT USB</b> , German/English	<b>900-891-MPI21</b>

## Features

- Support for all common S7 Engineering Tools
- For S7-200<sup>1)</sup>, S7-300<sup>1)</sup>, S7-400<sup>1)</sup>
- Up to 32 links on MPI/PROFIBUS
- Support of slave parameterization
- Electrical isolation to the MPI/PPI/PROFIBUS
- MPI/PPI/PROFIBUS with 9.6 kbps to 12 Mbps
- USB 2.0 with up to 480 Mbps (Highspeed)
- 5 V power supply via USB
- 12 V power supply possible internally in the PC

## NETLink SLOT USB

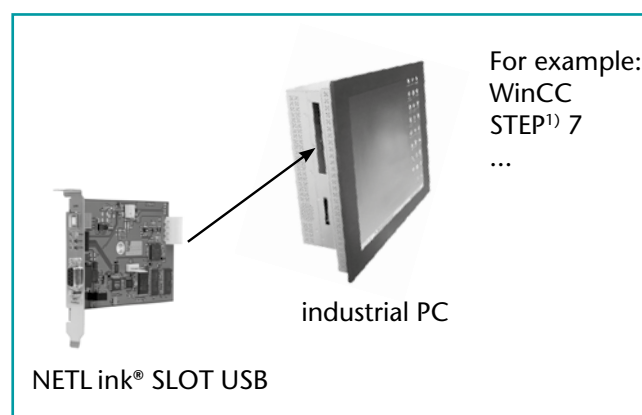

Application example NETLink® SLOT USB for industrial PCs

## Technical Data

Dimensions (D x W x H mm)	140 x 120 x 16
Weight	Approx. 180 g
<b>Power Supply</b> Voltage	DC 5 V USB, PC-power supply, automatically selected
Current consumption	typ. 350 mA at DC 5 V
<b>Communication interface</b> Type	USB 2.0
Connector	USB-B-female (extern) 4-way post plug connector for motherboard (intern)
Transmission rate	12 Mbps (Fullspeed)/ 480 Mbps (Highspeed)
<b>MPI/PPI/PROFIBUS</b> Type	RS485, isolated
Transmission rate	max. 12 Mbps, autodetection
Connector	SUB-D, 9-way
Protocols	FDL frames
Ambient temperature	0 °C ... 60 °C
Indicators	6 status LEDs
Degree of protection	Without degree of protection

1) S7-200, S7-300, S7-400, WinCC and STEP are registered trademarks of Siemens AG.

## OPC-Server

### Fast access to S7 and S5 data

The S7/S5 OPC server allows you fast and easy access to process data in WinAC<sup>1)</sup>, S7-200<sup>1)</sup>, S7-300<sup>1)</sup>, S7-400<sup>1)</sup>, C7- and S5 controllers.

Addressing of variables can be performed completely with S7 semantics and can be imported directly from an Excel file or a S7 project if required. With each OPC-compliant client application, you can read or write all input/output data, data blocks, flags, timers and counters in the S7/S5 controllers. You can also access up to 256 controllers at one time.

The control program does not have to be adapted for communication with the S7/S5 OPC server. No detailed knowledge of the PLC program that is running is necessary.

### New functions and expansions

On the S7-300<sup>1)</sup> and S7-400<sup>1)</sup> the DATE\_AND\_TIME and ASCII strings are supported as additional data formats. OPC Client Controls are now contained in the scope of supply of the S7/S5 OPC server as ActiveX components. The S5 syntax for creating items can now be used. Access to array elements has been improved.

### Integrated Web server

The S7/S5 OPC server features an integrated Web server. This is used for diagnosing the OPC server and for providing its own web pages for operating and monitoring using any standard browser. The architecture and performance of the web server is designed for small visualization systems.

### Flexible connection

There are many ways of connecting the controllers to the S7/S5 OPC server such as TCP/IP, PROFIBUS, MPI, PPI or AS511.

For communication, Systeme Helmholz GmbH provides the following devices:

- SSW7, SSW7-TS, SSW7-USB for MPI
- All products of NETLink<sup>®</sup> family
- SSW3, SSW4 and SSW5 for AS511

Also a selection of communication modules of other manufacturers, such as CP243, CP343, and CP443 from Siemens are supported.

The current OPC server version and further technical information are available for download at [www.helmholz.de](http://www.helmholz.de).

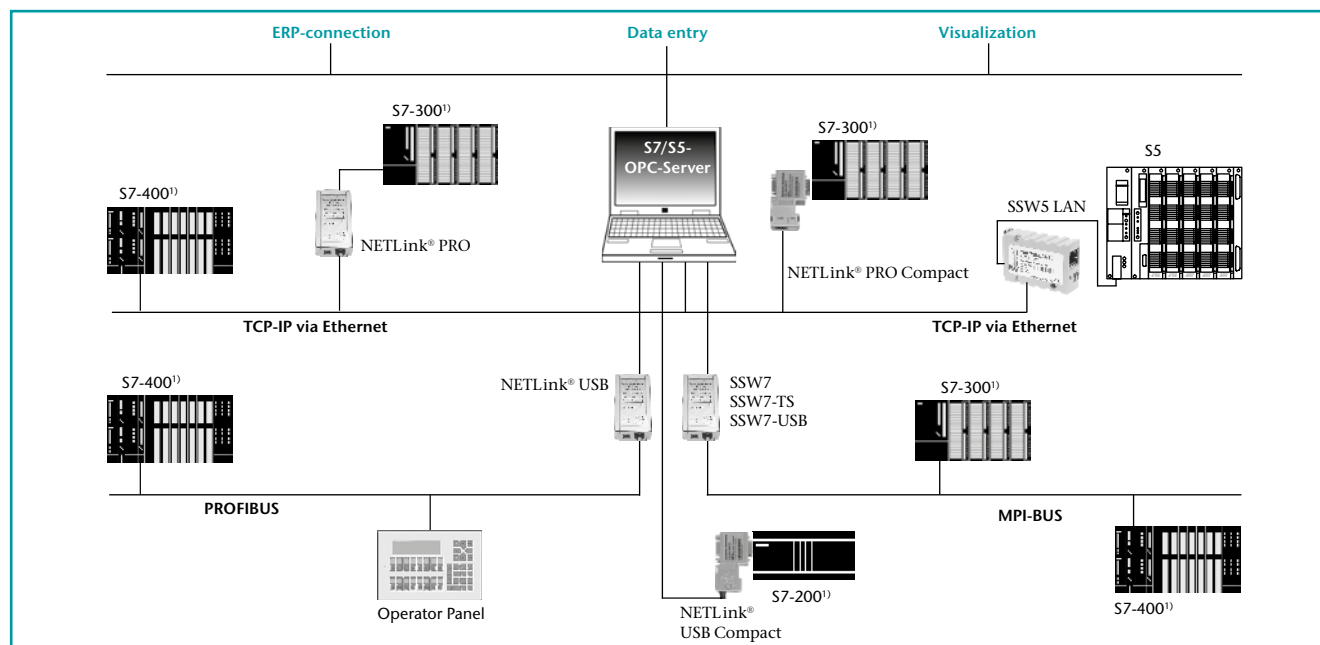
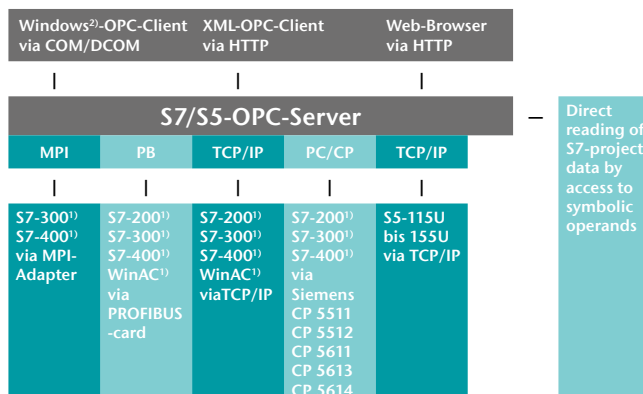

Application example for OPC-Server

### Ordering Data

	Order No.
S7-OPC-Server with USB-Dongle	800-880-OPC20

1) WinAC, S7-200, S7-300, S7-400, STEP and WinCC are registered trademarks of Siemens AG.

2) Windows is a registered trademark of Microsoft Corporation.



# Teleservice

Router  
Adapter for Teleservice  
Teleservicemodule  
Modems

## REX 300, Ethernet Router



REX 300

The REX 300 industrial router provides you with maximum flexibility and greatest possible security. With the router, you can remotely establish simple and secure communication with your plants.

Due to its S7-300<sup>1)</sup> design, the REX 300 can easily be integrated into an S7-300<sup>1)</sup> system and, with the included PG/PC interface driver, it can be used within all common Simatic<sup>1)</sup> Engineering Tools.

The REX 300 is easy to configure via its web user interface. Irrespective of the way the connection with the internet is established (analog, ISDN, EDGE/GPRS/GSM or DSL), the integrated, application-oriented configuration wizard makes configuration of the VPN, internet, and network connection easier. It permits ready-to-use configuration within a matter of minutes. The free my-REX services of Systeme Helmholtz GmbH make it easier to access the router via the internet with dynamic name resolution or by sending e-mails from the assigned IP address of the internet provider.

Because of the additional RS interface, in versions with a WAN connection, it is also possible to include serial devices in the remote maintenance.

### VPN portal myREX24

Using the myREX24 central exchange, you bypass the time-consuming firewall pass-through authorisations or service requests for your customer or mobile telecom operator. The setting up is simplified enormously because one outgoing connection is established in each case from the point of view of the system or user. The connections are established via VPN whereby their data are transmitted encrypted.

Your benefits:

- Access via [www.myREX24.net](http://www.myREX24.net)
- Configuration on myREX24
- Configuration can be downloaded
- Complete control of active connections due to comprehensive status information
- User management system
- Software for easy communication establishment

### Features

- MPI/PROFIBUS up to 12 Mbps
- Teleservice Ethernet devices over the internet
- Support for all common Simatic<sup>1)</sup> Engineering Tools
- S7-300<sup>1)</sup>, S7-400<sup>1)</sup> via MPI/PROFIBUS
- Configuration of the REX 300 on the web user interface through the locally connected PC or by remote control
- Configuration wizard for simple set-up
- Deployable worldwide due to its range of different modem connections, such as analog, ISDN, GPRS/EDGE and access via LAN and internet (DSL, etc.)
- Establishment of secure connections through the integrated firewall with IP filter, NAT/PAT, VPN
- Teleservice serial devices over the internet
- DNS via [www.my-REX.net](http://www.my-REX.net)

# REX300

[myREX24.net](http://myREX24.net)

### Accessory-Note

For GSM antennas, see page 88.

To connect serial devices to the REX 300 with WAN connection, an adapter cable for the RS interface is required.

Ordering Data	Order No.
<b>REX 300 without VPN, analog</b> (incl. telephone cable, Ethernet cable, Quick Start Guide)	700-870-MDM01
<b>without VPN, ISDN</b> (incl. telephone cable, Ethernet cable, Quick Start Guide)	700-870-ISD01
<b>without VPN, EDGE</b> (incl. Ethernet cable, Quick Start Guide)	700-870-EDG01
<b>with VPN, analog</b> (incl. telephone cable, Ethernet cable, Quick Start Guide)	700-871-MDM01
<b>with VPN, ISDN</b> (incl. telephone cable, Ethernet cable, Quick Start Guide)	700-871-ISD01
<b>with VPN, EDGE</b> (incl. Ethernet cable, Quick Start Guide)	700-871-EDG01
<b>VPN + WAN, analog + serial interface</b> (incl. telephone cable, Ethernet cable, Quick Start Guide)	700-872-MDM01
<b>VPN + WAN, ISDN + serial interface</b> (incl. telephone cable, Ethernet cable, Quick Start Guide)	700-872-ISD01
<b>VPN + WAN, EDGE + serial interface</b> (incl. Ethernet cable, Quick Start Guide)	700-872-EDG01
<b>VPN+WAN, without Modem</b> (incl. Ethernet cable, Quick Start Guide)	700-873-WAN01
<b>Adapter cable RS interface</b> for REX 300, 3 m, 9-way male connector	700-879-1VK11
<b>Mounting rail adapter</b> for DIN rail (optional)	700-390-6BA01
<b>Mounting rail</b> 40 mm	700-390-1XA04
<b>Manual REX 300</b> , German/English	900-87x-REX300

1) S7-300, S7-400 and Simatic are registered trademarks of Siemens AG.

REX 300, Ethernet Router

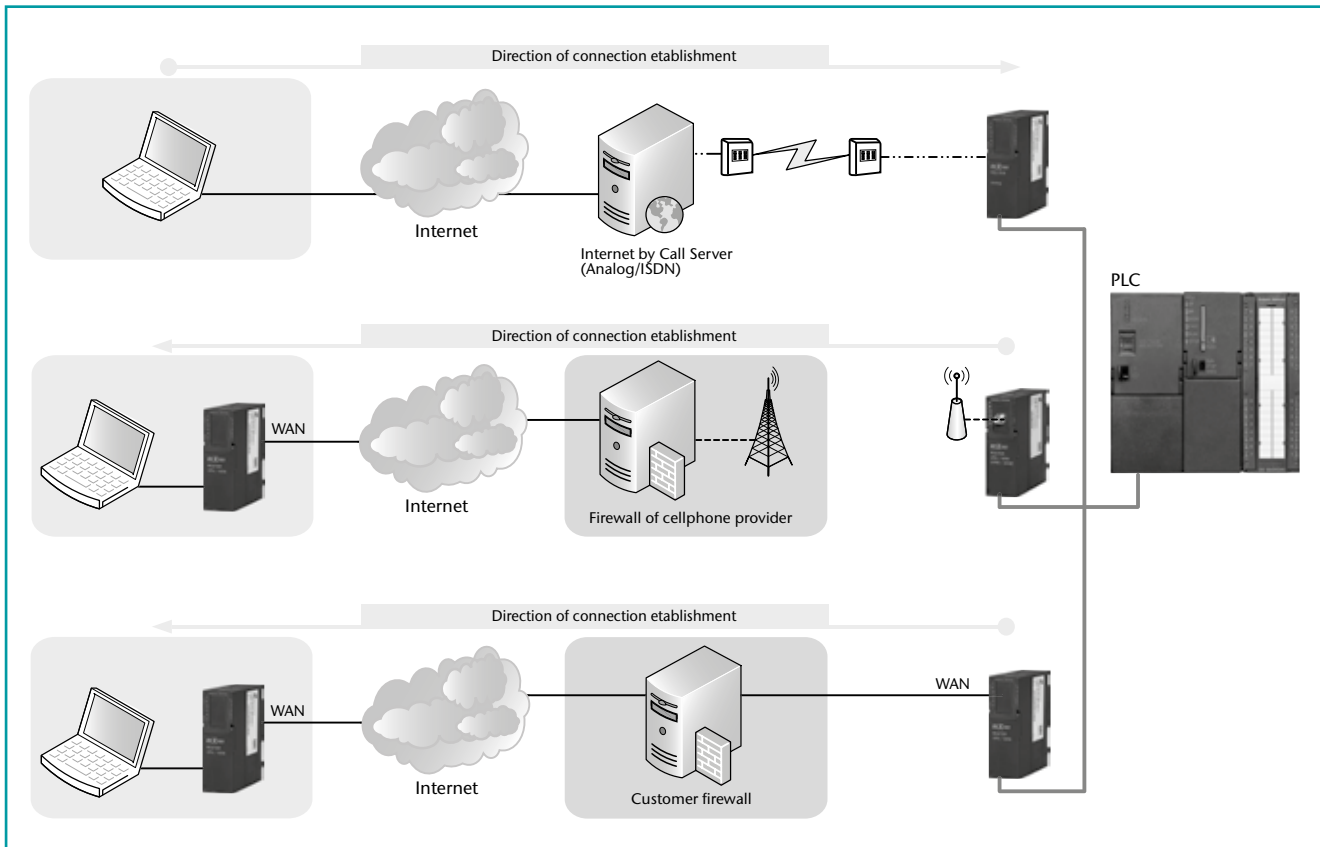

Possible connections to REX 300

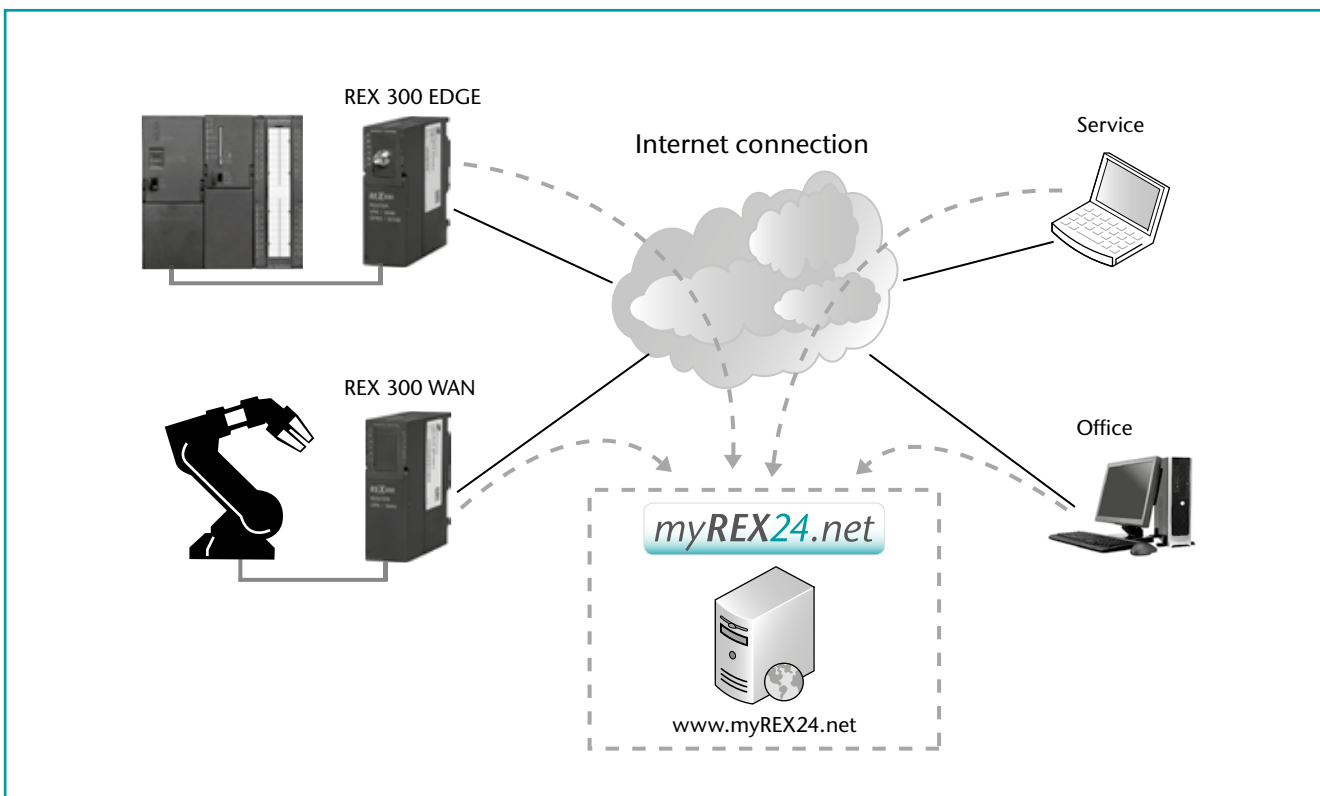

Application with myREX24

## REX 300, Ethernet Router

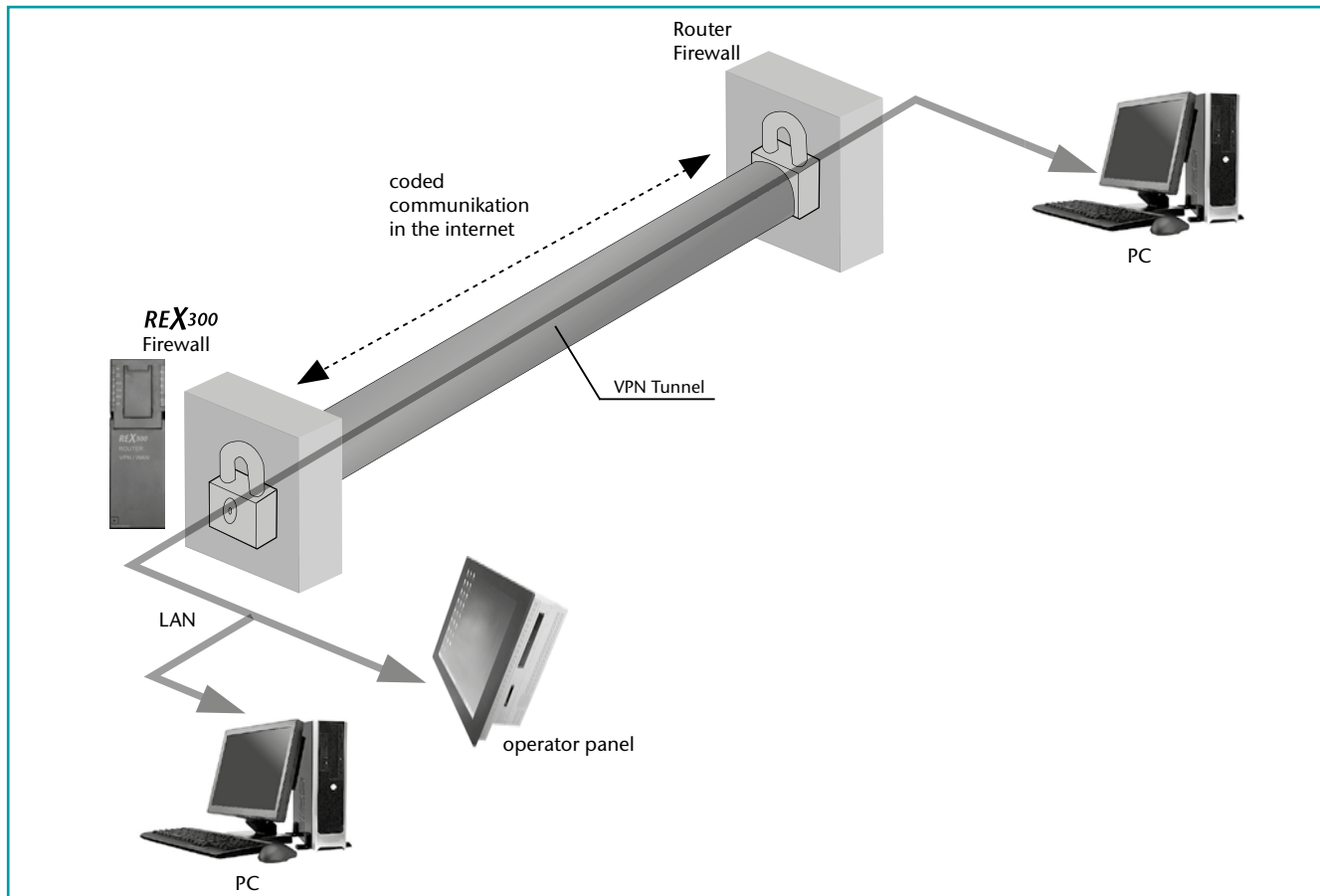

Application example REX 300 with VPN

Technical Data	
Dimensions (D x W x H mm)	116 x 40 x 124 mm
Weight	Approx. 300 g
<b>Modem</b>	Analog/ISDN/ GSM (GPRS/EDGE)
<b>Router Functions</b>	Dial In, Dial Out, call-back function, DHCP server and client, firewall, DynDNS, NAT/PAT, SMS control
VPN	IPSec, PPTP, OpenVPN
<b>Authentication</b>	
PPP	PAP, CHAP
VPN	PSK, X.509 certificates
Encryption (VPN)	AES, DES/3DES
<b>Ports</b>	
LAN/WAN	100 Mbps for full and half-duplex operation, automatic detection, autosensing
MPI/PROFIBUS	RS485 - 9,6 kbps to 12 Mbps
Serial	RS232, RS485 (2- and 4-wire), RS422
<b>Configuration</b>	
Web interface	Local/remote
<b>Power supply</b>	
Voltage	10 VDC ... 30 VDC
Current consumption	Max. 250 mA
Ambient temperature	0 °C ... +60 °C
Degree of protection	IP 20



## SSW7-TS, MPI Adapter



SSW7-TS

The SSW7-TS can be used to teleservice your system via a modem connection. For this, you can connect a commercially available external modem (analog, ISDN, GSM) to the RS232-interface of the SSW7-TS. For local use, you simply connect the RS232 interface of the SSW7-TS to your PC. The SSW7-TS automatically detects the baud rate (9.6–115.2 kbaud) used by the PC. At the system end, you can connect the SSW7-TS to an MPI network with 187.5 or 19.2 kbps.

The PC must be installed with the teleservice module for the programming software (e.g. TeleService for Simatic STEP<sup>1</sup> 7) so that the SSW7-TS can be parameterized if necessary, and the modem connection maintained. Without modems or the teleservice module the SSW7-TS can be operated at the machine as a SSW7. The voltage supply for the SSW7-TS is taken from the CPU via the MPI bus. With an optional 24 V connection it can be operated anywhere else in the system.

The SSW7-TS can also be provided with a new firmware via a modem connection. Therefore a function upgrade of an adapter already installed in the system is also possible.

**Accessory-Note**

DIN rail adapter, extension cables (on request) as well as multiplexers (see page 106) are available for the SSW7-TS.

By using SHTools software parameterization and diagnostic functions are possible. For firmware update a free download of the latest SHTools version is available on our website [www.helmholz.com](http://www.helmholz.com).

Ordering Data	
	Order No.
<b>MPI-Adapter</b> SSW7-TS (incl. manual, CD with software)	700-751-8VK21
<b>DIN rail adapter short Power Plug</b> (optional)	700-751-HSH01 700-751-SNT01

1) Simatic and STEP are registered trademarks of Siemens AG.

**Features**

- Teleservice via external modem (analog, ISDN, GSM)
- Usable with Hayes compatible modems
- Password
- Call-back function
- Online update function
- In-situ use as programming adapter
- MPI up to 187.5 kbps

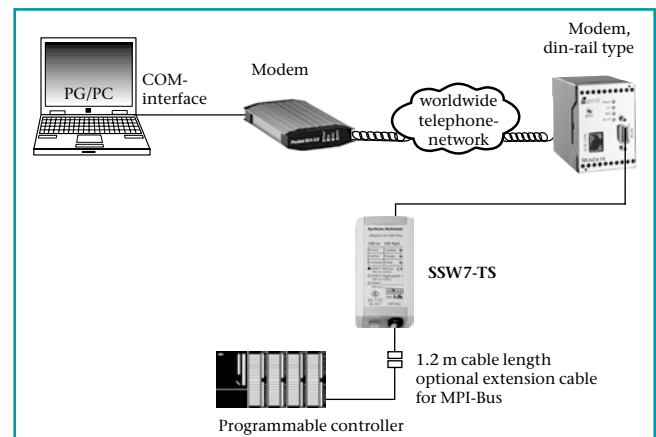

Application example for SSW7-TS

Technical Data	
Dimensions (D x W x H mm)	105 x 53 x 29
Weight	Approx. 180 g
Supply voltage	+24 V ±25 % from PLC or extern
Current consumption	typ. 30 mA max. 45 mA
<b>MPI interface</b>	
Type	RS485
Transmission rate	19.2 or 187.5 kbps
Cable connector	SUB-D, 9-way with PG interface and terminating resistor
<b>Communication interface</b>	
Type	RS232
Transmission type	Serial asynchronous
Transmission rate	9.6 ... 115.2 kbps
Parity	Odd
Data format	8 Bit
Protocols	PC <-> S7 via modem or local
Connection	Connector, SUB-D, 9-way
Degree of protection	IP 20

## SSW7-TS with Modem; analog/ISDN/GSM

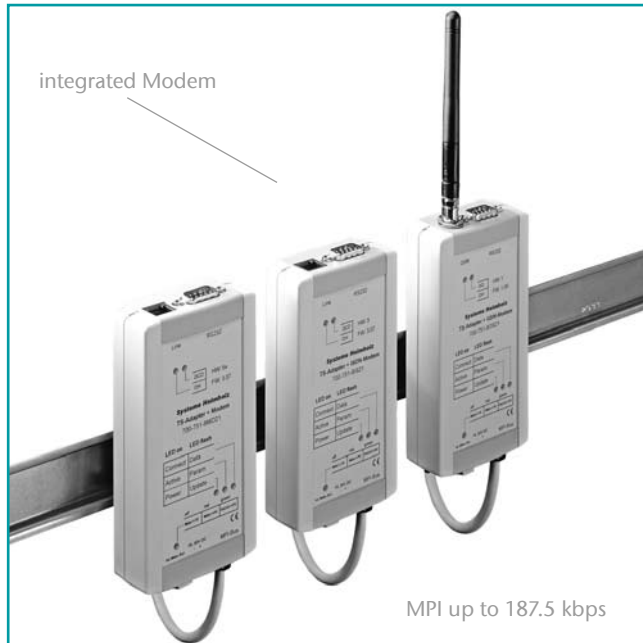

SSW7-TS with Modem

The SSW7-TS with integrated modem is a low-cost alternative for teleservicing a programmable controller via the MPI bus. Depending on the version, an analog, ISDN, or GSM modem is integrated in the housing of the SSW7-TS. The analog modem can be configured for worldwide use. The ISDN variant supports the DSS1 protocol that is used in many countries. All connecting cables required for operation are included. The SSW7-TS with a GSM modem (quadband) is the right choice for mobile use or if a telephone connection is not available.

Via the serial interface, the SSW7-TS with modem can also be used as a PC adapter for local use. The modem can be used for teleservicing a VISU/SCADA application even without a TS adapter function. Settings are made using microswitches on the adapter housing.

The SSW7-TS with modem receives its power supply from the CPU via the MPI cable. If no 24 V supply is available at the connection point, it is possible to feed in an external 24 V power supply.

The SSW7-TS with modem can also be updated with new firmware via a modem link.

That enables functional expansion of an adapter already installed in the system.

Ordering Data	
	Order No.
<b>MPI-Adapter SSW7-TS with modem analog</b> (incl. DIN rail adapter, 2 x telephone cable RJ11 + TAE each 3 m, 3 m programming cable, manual, CD with software)	700-751-8MD21
<b>SSW7-TS with modem ISDN</b> (incl. DIN rail adapter, RJ11 telephone cable 3 m; 3 m programming cable, manual, CD with software)	700-751-8IS21
<b>SSW7-TS with modem GSM</b> (incl. DIN rail adapter, 3 m programming cable, manual, CD with software)	700-751-8GS21
<b>Power Plug (optional)</b>	700-751-SNT01

### Features

- MPI up to 187.5 kbps
- Teleservice and in-situ use
- Password protection and call-back function
- RS232-interface
- Online update function
- DIN rail adapter for mounting included in scope of supply

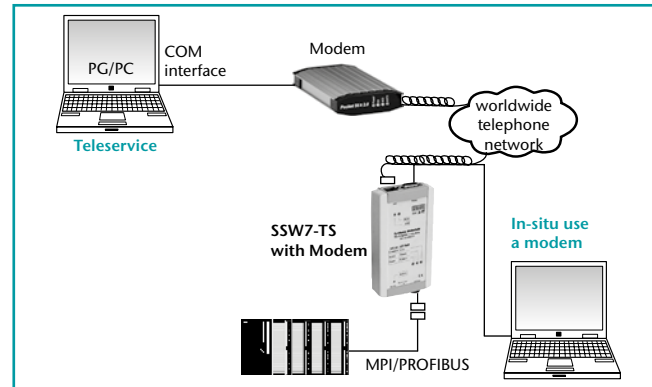

Application example for SSW7-TS with Modem analog

### Accessory-Note

Systeme Helmholtz GmbH always provides the latest version of the required SHTools software on its website for downloading. The SSW7-TS with GSM modem requires a SIM card with CSD service (Circuit Switched Data) activated and a suitable GSM antenna (see page 88).

Technical Data	
Dimensions (D x W x H mm)	135 x 67 x 30
Weight	Approx. 240 g
Supply voltage	+24 V $\pm$ 25 % from PLC or extern
Current consumption	Analog/ISDN approx. 100 mA, GSM approx. 150 mA
<b>MPI interface</b>	
Type	RS485
Transmission rate	19.2 or 187.5 kbps
Cable connector	SUB-D, 9-way with PG interface and terminating resistor
<b>Communication interface</b>	
Type	RS232; 2-wire dial-up (analog); ISDN S <sub>0</sub>
<b>GSM-Frequency</b>	Quadband: GSM850, EGSM900, DCS1800, PCS1900
Transmission type	Serial asynchronous
Transmission rate	9.6 ... 115.2 kbps
Protocols	PC <-> S7 via modem or local
Connection	Connector, SUB-D, 9-way RJ11 or SIM card slot
Degree of protection	IP 20

## SSW7-TS PRO analog/ISDN/GSM

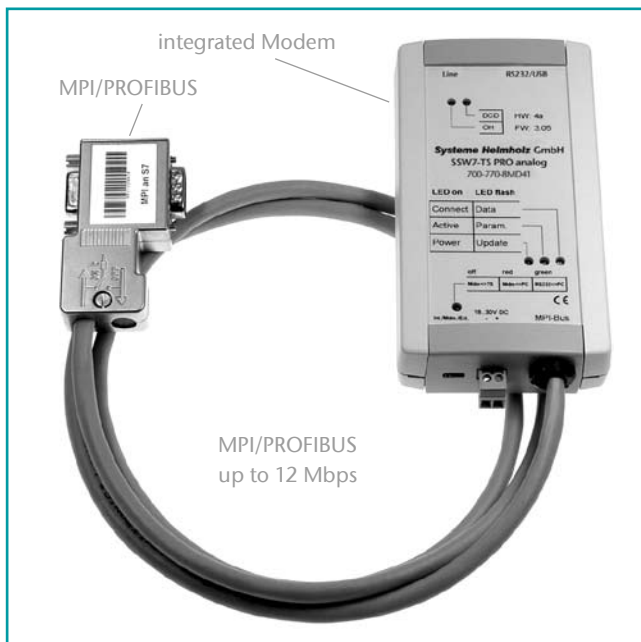

SSW7-TS PRO; analog

The SSW7-TS PRO can be used for teleservicing a S7 system via a modem connection and supports connection of the system to an MPI or PROFIBUS network with up to 12 Mbps.

Depending on the version, an analog, ISDN, or GSM modem is integrated in the housing of the SSW7-TS PRO. The analog modem can be configured for worldwide use. The ISDN variant supports the DSS1 protocol that is used in many countries. The SSW7-TS PRO GSM is the right choice for mobile use or if a telephone connection is not available.

In addition to use as a remote service solution, the SSW7-TS PRO can also be used locally as a PC adapter via its RS232 or USB interface.

The MPI/PROFIBUS connecting cable of the SSW7-TS PRO is not a spur line because of the repeater integrated into the connector. It allows the adapter to be connected at any point along the bus even at 12 Mbps.

The SSW7-TS PRO usually draws its power supply via the MPI/PROFIBUS connecting cable or, if necessary, via the external power source. Using the free software SHTools, firmware updates can be transmitted directly via the RS232/USB and via the modem connection on the SSW7-TS PRO.

Ordering Data	
	Order No.
<b>MPI-Adapter SSW7-TS PRO analog</b> (incl. DIN rail adapter, 2x telephone cable RJ11 + TAE each 3 m, 3 m programming cable, USB cable, manual, CD with software)	700-770-8MD41
<b>SSW7-TS PRO ISDN</b> (incl. DIN rail adapter, RJ11 telephone cable 3 m, 3 m programming cable, USB cable, manual, CD with software)	700-770-8IS41
<b>SSW7-TS PRO GSM</b> (incl. DIN rail adapter, 3 m programming cable, USB cable, manual, CD with software) <b>(GSM antennas see page 88)</b>	700-770-8GS41
<b>Power Plug (optional)</b>	700-751-SNT01

## Features

- MPI/PROFIBUS up to 12 Mbps; autobaud
- Teleservice and in-situ use
- Password protection and call-back function
- RS232 and USB interface
- Remote updating possible
- **New feature:** Transmission of any SMS messages from the PLC

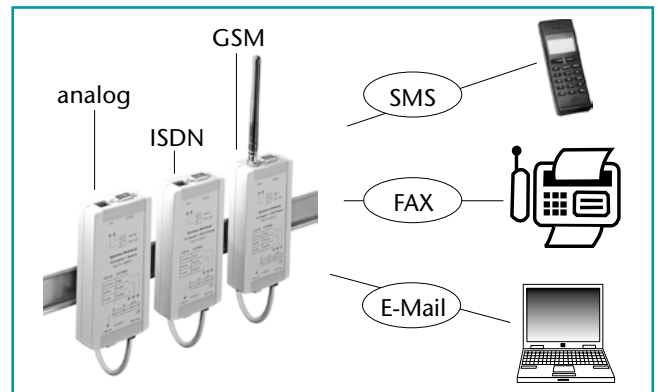

Application example for SSW7-TS PRO analog/ISDN/GSM

As a new feature, the SSW7-TS PRO now also supports transmission of any SMS messages. SMS transmission is triggered by calling the SMS\_SEND function block from the programmable controller. Depending on the SMS service provider used, it is also possible to send messages to an e-mail address or fax machine.

## Accessory-Note

The SSW7-TS PRO GSM additionally requires a SIM card with the CSD service (Circuit Switched Data) activated and a suitable GSM antenna. (For GSM antennas, see page 88).

Technical Data	
Dimensions (D x W x H mm)	130 x 67 x 30
Weight	Approx. 240 g
Supply voltage	+24 V ±25 % from PLC or extern
Current consumption	Approx. 130 mA
<b>MPI interface</b>	
Type	RS485
Transmission rate	9.6 kbps - 12 Mbps
Cable connector	SUB-D, 9-way with PG interface and terminating resistor
<b>Communication interfaces</b>	
Type	RS232; 2-wire dial-up (analog), ISDN S <sub>0</sub> ; USB
<b>GSM-Frequency</b>	Quadband: GSM850, EGSM900, DCS1800, PCS1900
Transmission type	Serial asynchronous/USB
Transmission rate	9.6 ... 115 kbps
Data format	8 Bit
Protocols	PC <-> S7 via modem or local
Connection	Connector, SUB-D, 9-way RJ11; Mini-USB female connector
Degree of protection	IP 20

## TS 300, Teleservicemodule for the PLC Rack



TS 300, Teleservicemodule for the PLC-Rack

With the TS 300, teleservice of a system can be performed via the MPI bus.

The TS 300 has a single-width S7-300<sup>2)</sup> housing for mounting on the sectional rail. A 56k modem is integrated into the housing of the TS 300 that is prepared for use worldwide. A flash update is no longer necessary. TAE and RJ11 cables are included in the scope of supply. As alternatives, versions with ISDN or GSM modem are also available.

The TS 300 can establish an MPI link with the CPU via the backplane bus. The power supply is also drawn from the backplane bus. Therefore, for installation of a teleservice solution, only the phone line is required.

The TS 300 does not need to be configured in the hardware configuration of the PLC and can therefore be retrofitted at any time. Alternately, the TS 300 can be powered from an external 24 V source. The MPI connection can also be established via the 9-way sub D jack on the front.

An additional USB connection is used to parameterize the TS 300, for in-situ use as a PC adapter, or for direct use of the internal modem.

### Features

- MPI up to 187.5 kbps
- TS adapter in the S7 rack for Teleservice
- Analog, ISDN, GSM
- USB interface for parameterization or in-situ use
- Password protection
- Call-back function
- Online update function
- Alert functions and switch outputs usable via back plane bus
- Mode change via Teleservice
- Up to two alarm messages can be transmitted by SMS per module
- Communication via the backplane bus possible<sup>1</sup>

The TS 300 can also be updated with a new operating system via a remote link. That enables functional expansion of a TS 300 already installed in the system.

By using SHTools software parameterization and diagnostic functions are possible. For firmware update a free download of the latest SHTools version is available on our website [www.helmholz.com](http://www.helmholz.com).

### Accessory-Note

For GSM antennas, see page 88.

### Ordering Data

	Order No.
<b>TS 300 with modem analog</b> (incl. 3 m USB cable, 2x telephone cable RJ11+TAE each 3m, manual, CD with software)	700-753-8MD21
<b>TS 300 with modem ISDN</b> (incl. 3 m USB cable, 1x RJ11 telephone cable 3m, manual, CD with software)	700-753-8IS21
<b>TS 300 with modem GSM</b> (incl. 3 m USB cable, manual, CD with software) (GSM antennas see page 88)	700-753-8GS21
<b>MPI-connecting cable, 0.5 m</b>	700-753-6VK11
<b>Mounting rail Adapter for DIN rail (optional)</b>	700-390-6BA01
<b>Mounting rail 40 mm</b>	700-390-1XA04

1) It is advised against a MPI functionality at the back plane bus when using the following CPUs: S7-315 2 DP/PN, S7-317, S7-318 and S7-319 State: 06-2007

2) S7-300 is a registered trademark of Siemens AG

## TS 300, Teleservicemodule for the PLC Rack

Technical Data			
	TS 300 analog	TS 300 ISDN	TS 300 GSM
Degree of protection	IP 20	IP 20	IP 20
Dimensions (D x W x H)	116 x 40 x 124 mm	116 x 40 x 124 mm	116 x 40 x 124 mm
Weight	Approx. 280 g	Approx. 280 g	Approx. 280 g
Operating voltage	DC +24 V $\pm$ 25 %, external or 5 V via backplane bus	DC +24 V $\pm$ 25 %, external or 5 V via backplane bus	DC +24 V $\pm$ 25 %, external
Current consumption	Approx. 500 mA (backplane bus) Approx. 140 mA (external)	Approx. 500 mA (backplane bus) Approx. 140 mA (external)	Approx. 50 mA (backplane bus) Approx. 170 mA (external)
Ambient temperature	0 °C to +60 °C	0 °C to +60 °C	0 °C to +60 °C
<b>MPI interface</b>			
Type	RS485	RS485	RS485
Transmission rate	19.2 or 187.5 kbps	19.2 or 187.5 kbps	19.2 or 187.5 kbps
Connection	SUB-D, 9-way socket or via backplane bus	SUB-D, 9-way socket or via backplane bus	SUB-D, 9-way socket or via backplane bus
<b>USB communication interface</b>			
Type	USB 2.0, USB 1.1 compliant	USB 2.0, USB 1.1 compliant	USB 2.0, USB 1.1 compliant
Connection	USB-B socket for internal modem or TS adapter	USB-B socket for internal modem or TS adapter	USB-B socket for internal modem or TS adapter
Transmission rate	9.6 kbps to 115.2 kbps via virtual COM port	9.6 kbps to 115.2 kbps via virtual COM port	9.6 kbps to 115.2 kbps via virtual COM port
<b>Modem</b>	Analog interface 56 kbps (V.92)	ISDN S0 interface acc. to ITU I.430, 64 kbps	Quadband: GSM850, EGSM900, DCS1800, PCS1900
Modem connection	RJ-11 socket	RJ-11 socket	3 V SIM card, FME connector for antenna
SMS transmission	2	2	2
Transmission standards	V.90, V.34+, V.34, V.32bis, V.32, V.22, V.22bis, V.21, V.23, BELL standard 103, 212 Fax Class 1, Fax Class 2	Transmission in D channel at 9,600 bps (X.31-D) Transmission in B channel at 64.000 bps (X.31-B))	Class 4 (2 W) for GSM850/EGSM900 Class 1 (1W) for DCS1800/PCS1900
Protocols		B channel: V.110, X75, X25/X31, HDLC (transparent) D channel: DSS1, X.31	

## MDM 300, Modem for the S7 Rack



MDM 300 modem for the S7 Rack

The MDM 300 of Systeme Helmholtz GmbH is a universal modem that can be installed in a single-wide S7-300<sup>1)</sup> housing for the sectional rail. A 56k modem is integrated into the housing of the MDM 300 that is prepared for use worldwide. Alternatively versions with ISDN or GSM functionality are also available. Besides teleservice of a VISU/SCADA system, the main application is global data exchange.

By using SHTools software parameterization and diagnostic functions are possible. For firmware update a free download of the latest SHTools version is available on our website [www.helmholz.com](http://www.helmholz.com).

### Accessory-Note

For GSM antennas, see page 88.

### Features

- RS232 9-way and USB with virtual COM port
- Destination countries worldwide (analog)
- Power supply via backplane bus or external 24 V
- SMS transmission (analog, ISDN)
- 2 digital inputs for transmitting SMS
- 2 outputs can be switched via telephone call

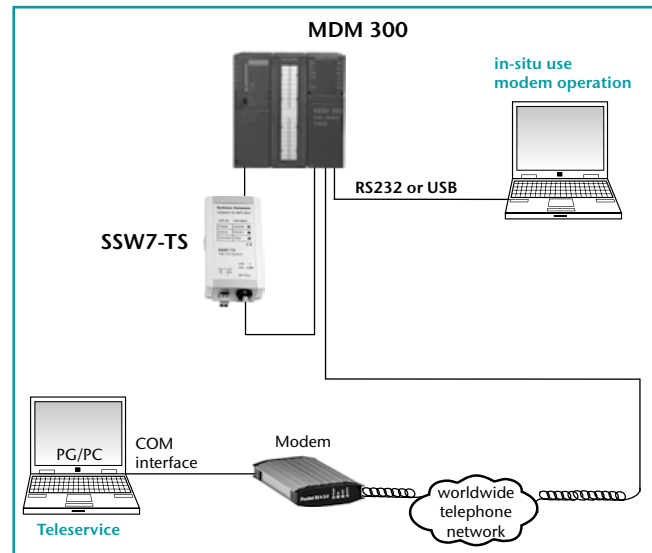

Application example MDM 300

### Ordering Data

	Order No.
<b>MDM 300 analog</b> (incl. RJ11 + TAE cable each 3m, RS232 connecting cable, USB cable, manual, CD with software)	700-754-1MD11
<b>MDM 300 ISDN</b> (incl. RJ11 cable 3m, RS232 connecting cable, USB cable, manual, CD with software)	700-754-1IS11
<b>MDM 300 GSM</b> (incl. RS232 connecting cable, USB cable, manual, CD with software) (GSM antennas see page 88)	700-754-1GS11
<b>Modem cable, 2 m</b>	700-754-7VK11
<b>Mounting rail Adapter</b> for DIN rail (optional)	700-390-6BA01
<b>Mounting rail 40 mm</b>	700-390-1XA04

1) S7-300 is a registered trademark of Siemens AG

## MDM 300, Modem for the S7 Rack

Technical Data			
	MDM 300 analog	MDM 300 ISDN	MDM 300 GSM
Degree of protection	IP 20	IP 20	IP 20
Dimensions (D x W x H)	116 x 40 x 124 mm	116 x 40 x 124 mm	116 x 40 x 124 mm
Weight	Approx. 280 g	Approx. 280 g	Approx. 280 g
Operating voltage	DC +24 V $\pm$ 25 %, external or 5 V via backplane bus	DC +24 V $\pm$ 25 %, external or 5 V via backplane bus	DC +24 V $\pm$ 25 %, external
Current consumption	Approx. 350 mA (backplane bus) Approx. 120 mA (external)	Approx. 350 mA (backplane bus) Approx. 120 mA (external)	Approx. 50 mA (backplane bus) Approx. 200 mA (external)
Ambient temperature	0 °C to + 60 °C	0 °C to + 60 °C	0 °C to + 60 °C
Number of inputs (in groups of)	2/2	2/2	2/2
Number of outputs (in groups of)	2/2	2/2	2/2
<b>Communication interface</b>	USB and RS232	USB and RS232	USB and RS232
USB interface Type	USB-B socket USB 2.0, USB 1.1 compliant	USB-B socket USB 2.0, USB 1.1 compliant	USB-B socket USB 2.0, USB 1.1 compliant
Transmission rate	9.6 kbps to 115.2 kbps via virtual COM port	9.6 kbps to 115.2 kbps via virtual COM port	9.6 kbps to 115.2 kbps via virtual COM port
RS232 interface	RS232, Sub-D 9-way socket	RS232, Sub-D 9-way socket	RS232, Sub-D 9-way socket
Transmission rate	9.6 kbps to 115.2 kbps	9.6 kbps to 115.2 kbps	9.6 kbps to 115.2 kbps
<b>Modem</b>	Analog interface 56 kbps (V.92)	ISDN-S0 interface acc. to ITU I.430, 64 kbps	Quadband: GSM850, EGSM900, DCS1800, PCS1900
Modem connection	RJ-11 socket	RJ-11 socket	3 V SIM card, FME connector for antenna
SMS transmission	2	2	2
Transmission standards	V.90, V.34+, V.34, V.32bis, V.32, V.22, V.22bis, V.21, V.23, BELL standard 103, 212 Fax Class 1, Fax Class 2	Transmission in D channel at 9.600 bps (X.31-D) Transmission in B channel at 64.000 bps (X.31-B)	Class 4 (2 W) for GSM850/EGSM900 Class 1 (1 W) for DCS1800/PCS1900
Protocols		B channel: V.110, X75, X25/X31, HDLC (transparent) D channel: DSS1, X.31	

## Antennas for GSM Modems

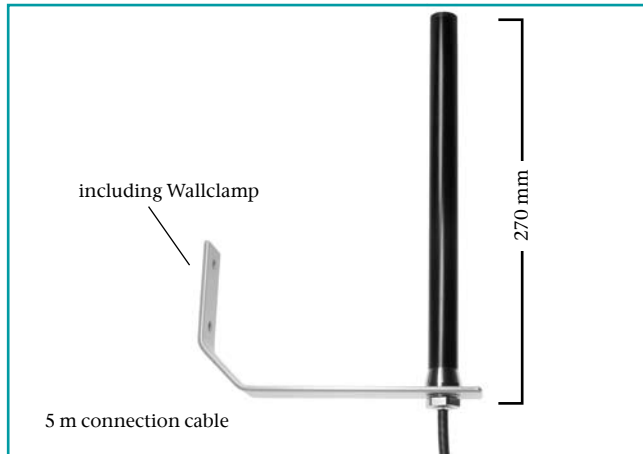

Static triband antenna for wall mounting (in- and outside)

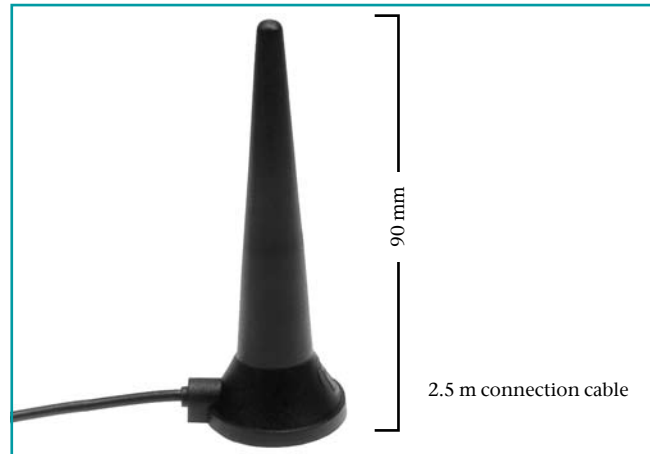

Quadband magnetic base antenna

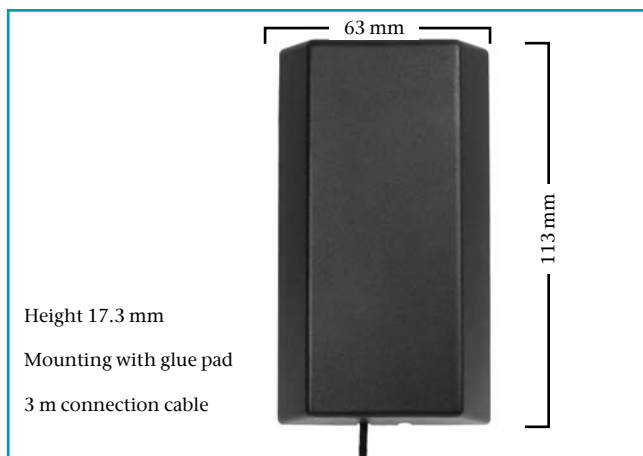

Patch triband antenna for wall mounting (inside)



Portable quadband antenna with integrated knee-joint for mobile use

To ensure the function of the GSM radio system in a – in most cases special – industrial environment, it is important to select a Systeme Helmholtz GSM antenna an advance for the greatest possible reliability.

Despite careful planning, the quality and speed of transmission always also depend on the level of development of and load on the GSM network.

To increase the flexibility still further, corresponding GSM extensions of various lengths are available as accessories for the antennas offered.

#### Outdoor antenna

The stationary triband antenna is a non-directional station antenna with a gain of up to 2 dBi. It is protected in a robust and weatherproof GFK conduit, is supplied with a wall mount, and is therefore especially suitable for mounting on vertical surfaces, such as building walls etc. It can be used equally well both outdoors and indoors. Metal surfaces should not be located in proximity to the emitting antenna. The 5 m long connecting cable is permanently connected to the antenna.

#### Magnetic base antenna

The quadband magnetically adhering antenna supports all relevant GSM radio frequencies. It adheres reliably to all magnetic surfaces because of its strong permanent magnet. Due to its compact dimensions, this omnidirectional antenna is ideal for mounting on the top or side of a cabinet. The 2.5 m long connecting cable provides a sufficient radius of action for this and is permanently connected to the antenna.

#### Top-mounting antenna

Patch antenna with a flat, robust design for indoor use. It is fixed by means of an adhesive pad on preferably horizontal surfaces. It functions independently of external grounding surfaces and can be mounted on nearly any material. The 3 m long connecting cable is permanently attached and can exit in the horizontal or vertical direction.

#### Portable antenna

Small omnidirectional antenna for direction connection to the GSM modem. Implemented as a dipole antenna, it ensures mobile use in the 900/1800 MHz band. For this type of antenna, a minimum clearance of 60 cm from other antennas and standing metal parts must be ensured on all sides in the application. The direction of emission can be optimized with the integrated knee-joint.

#### The antennas can be used in conjunction with the following products:

REX 300, SSW7-TS PRO, SSW7-TS with modem, TS 300 and MDM 300 in the GSM variant in each case.

#### Ordering Data

	Order No.
Local triband antenna	700-751-ANT01
Quadband magnetic base antenna	700-751-ANT02
Patch triband antenna	700-751-ANT03
Portable quadband antenna	700-751-ANT04
GSM antenna extension cable, 5 m	700-751-ANTK01
GSM antenna extension cable, 10 m	700-751-ANTK02
GSM antenna extension cable, 15 m	700-751-ANTK03





# CAN Bus

CAN Bus Modules for S7-300<sup>1)</sup>, S7-400<sup>1)</sup>  
DP/CAN Coupler  
CAN Bus Connector

<sup>1)</sup> S7-300 and S7-400 are registered trademarks of Siemens AG.

## CAN 300 PRO, Communication Module



CAN 300 PRO, communication module

The CAN 300 PRO module of Systeme Helmholtz GmbH for use in an S7-300<sup>1)</sup> from Siemens permits connection of CAN stations with the programmable controller.

The module can be slotted either in the central controller or in the expansion unit.

The CAN 300 PRO module supports CAN 2.0A (11 Bit) and CAN 2.0B (29 Bit) frames with a freely selectable baud rate of 10 kbps to 1 Mbps.

The CAN 300 PRO module can send and receive CAN frames in Layer 2 operating mode. The data of the CANopen<sup>®</sup> slaves can be processed as a process image in CANopen<sup>®</sup> Master operating mode in the PLC. Applications as a CANopen<sup>®</sup> Slave is also possible. Application examples are provided for standard applications including motor control with CANopen<sup>®</sup>. Data handling blocks for the SAE J1939 protocol are also available.

The CAN 300 PRO module contains 16 freely settable timers. Each timer can trigger a freely programmable CAN telegram. That way, it is easy to implement the synchronous protocols in common use in drive and servo systems using the CAN 300 PRO module.

The DIP switch for setting the baud rate and the station address facilitate commissioning. An optional micro memory card stores the project so that the parameterization or the module is quickly replaced during servicing.

6 LEDs indicate the operating status of the module. A USB interface is available for diagnostics and parameterization tasks.

The CAN 300 PRO also works in the extended ambient temperature range of -25 °C to +60 °C.

A USB cable is included.

Ordering Data	
	Order No.
CAN 300 PRO, communication module (incl. USB programming cable)	700-600-CAN12
Micro Memory Card, 256 kByte	700-953-8LH11
Manual CAN 300 PRO, German/English	900-600-CAN12
CAN Training Course (see page 124)	400-600-CAN01

1) S7-300 is a registered trademark of Siemens AG

### Features

- Layer 2, 11 Bit and 29 Bit (CAN 2.0 A/B)
- CANopen<sup>®</sup> Master on the module
- DIP switch for address + baud rate
- Micro Memory Card for saving a project (optional)
- USB Interface for parameterization and diagnostics
- Extensive CAN-Bus diagnostics
- Can also be used as a CANopen<sup>®</sup> slave
- Extended ambient temperature range

**CAN**  
connected

**CANopen**<sup>®</sup>

Member of: **cia**<sup>®</sup>

### Note

On page 96 you will find information about the parameterization software CANParam and about the data handling blocks for the PLC.

When first used, data handling blocks are required for the PLC.

Technical Data	
Dimensions (D x W x H mm)	116 x 40 x 125
Weight	Approx. 280 g
<b>Power supply</b> Voltage	+5 V DC via backplane bus
Current consumption	typ. 160 mA max. 190 mA
<b>CAN interfaces</b> Type	ISO/DIN 11898-2 CAN High Speed physical Layer
Transmission rate	10 kbps to 1 Mbps
Protocol	CAN 2.0A (11 Bit) CAN 2.0B (29 Bit) CANopen <sup>®</sup> Master CANopen <sup>®</sup> Slave SAE J1939 DeviceNet Slave (on request)
Connection	Connector, SUB-D, 9-way
Status display	6 LEDs
<b>Configuration interfaces</b> Type	USB 1.1
Connection	USB-B female connector
Ambient temperature	-25 °C ... 60 °C
Transport and storage temperature	-25 °C ... 75 °C

CAN 300 PRO, Communication Module

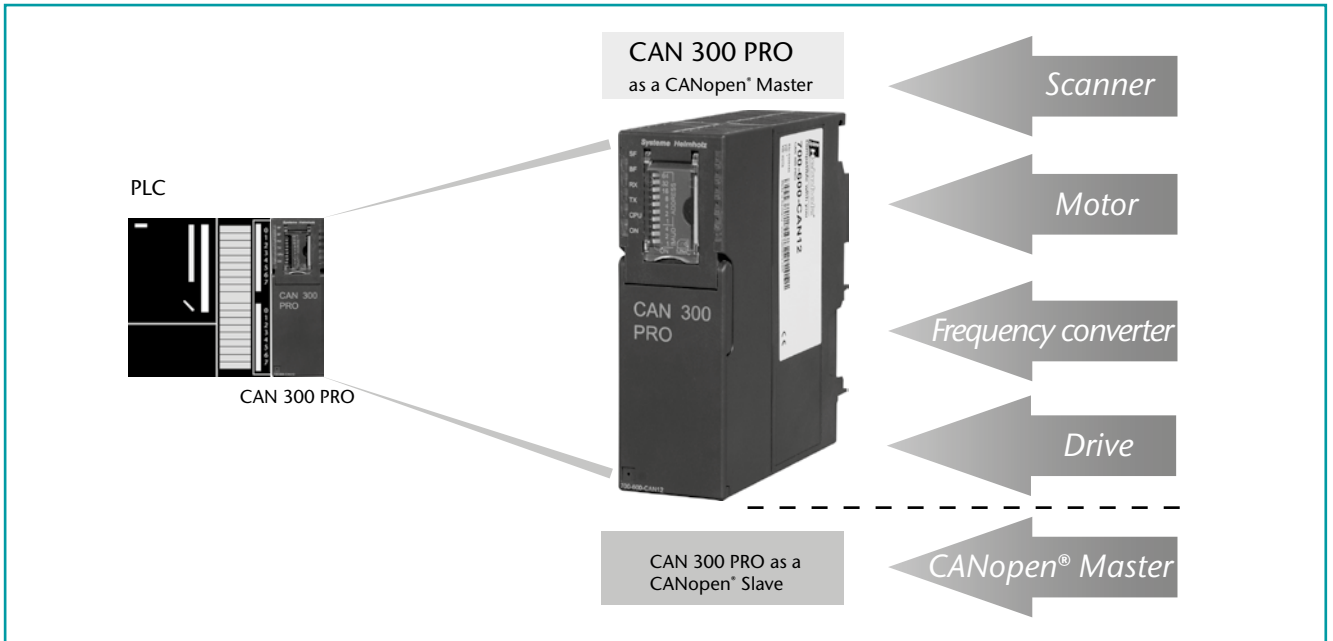

Application Example CAN 300 PRO as a CANopen<sup>®</sup> Master/Slave



Application Example CAN 300 PRO SAE J1939 Protocol

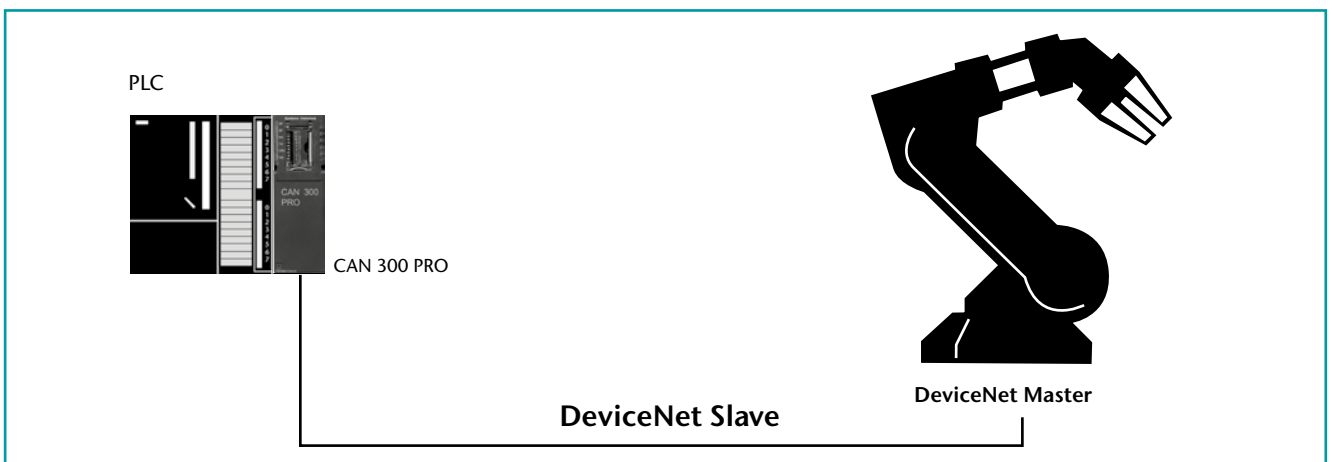

Application Example CAN 300 PRO as a DeviceNet Slave

## CAN 300, Communication Module with DNV certificate



CAN 300, communication module (DNV)



The CAN 300 module from the Systeme Helmholtz GmbH for use in a S7-300<sup>1)</sup> from Siemens permits connection of CAN stations with the programmable controller. The module can be slotted either into the central controller or into the expansion unit.

The CAN 300 modules support both CAN 2.0A (11 Bit) and CAN 2.0B (29 Bit) frames with a free selectable baud rate of 10 kbps to 1 Mbps.

The CAN 300 module can also be run as Layer 2, CANopen<sup>®</sup> Master, and CANopen<sup>®</sup> Slave.

The CAN 300 module contains the power management functions "Power On", "Stop -> Run" and "Run -> Stop". IDs relevant to the programmable controller can be prefiltered using a 5-level acceptance mask.

In CAN 300 modules 11 free settable timers are available. Each timer can trigger a free programmable CAN frame. In that way, it is simple to implement synchronous protocols commonly used in drive and servo control using the CAN 300 module.

**Note**

Information about software and handling blocks is available on page 96.

When first used, data handling blocks are required for the PLC.

The CAN 300 module is DNV (Det Norske Veritas) "peripheral equipment" approved for increased application conditions.

Ordering Data	
	Order No.
CAN 300, communication module (DNV)	700-600-CAN81
RS232 Parameterization cable, serial PC to CAN 300 communication module	700-610-0VK11
Manual CAN 300, German/English CAN Training Course (see page 124)	900-600-CAN01 400-600-CAN01

1) S7-300 is a registered trademark of Siemens AG

Technical Data	
Dimensions (D x W x H mm)	116 x 40 x 125
Weight	Approx. 280 g
<b>Power supply</b> Voltage	+5 V DC via backplane bus
Current consumption	typ. 160 mA max. 190 mA
<b>CAN interfaces</b> Type	ISO/DIN 11898 -2 CAN High Speed physical Layer
Transmission rate	10 kbps to 1 Mbps
Protocol	CAN 2.0A (11 Bit) CAN 2.0B (29 Bit) CANopen <sup>®</sup> Master CANopen <sup>®</sup> Slave SAE J1939
Connection	Connector, SUB-D, 9-way
<b>Configuration interfaces</b> Type	RS232, serial asynchronous
Transmission rate	9.6 kbps
Format	8/N/1
Connection	Connector, SUB-D, 9-way
Ambient temperature Transport and storage temperature	-25 °C ... 60 °C -25 °C ... 75 °C

## CAN 400, Communication Module



CAN 400, communication module

The CAN 400 module from the Systeme Helmholtz GmbH for use in a S7-400<sup>1)</sup> from Siemens permits connection of CAN stations with the programmable controller. The module can be slotted either into the central controller or into the expansion unit.

The CAN 400 modules support both CAN 2.0A (11 Bit) and CAN 2.0B (29 Bit) frames with a free selectable baud rate of 10 kbps to 1 Mbps.

The CAN 400 module can also be run as Layer 2, CANopen<sup>®</sup> Master or CANopen<sup>®</sup> Slave.

The CAN 400 module contains the scripts "Power On", "Stop -> Run", "Run -> Stop", "Power Off". IDs relevant to the programmable controller can be prefiltered using a 5-level acceptance mask. In CAN 400 modules, 16 free settable timers up to a resolution of 1ms are available. Each timer can trigger a free programmable CAN frame. In that way, it is simple to implement synchronous protocols commonly used in drive and servo control using the CAN 400 module.

**Note**

Information about software and handling blocks is available on page 96.

When first used, data handling blocks are required for the PLC.

Ordering Data	
	Order No.
CAN 400-1, Communication module with 1 CAN interface	700-640-CAN11
CAN 400-2, Communication module with 2 CAN interfaces	700-640-CAN21
Manual CAN 400, German/English	900-640-CAN21
CAN Training Course (see page 124)	400-600-CAN01

1) S7-400 is a registered trademark of Siemens AG

**CAN**  
connected

**CANopen**<sup>®</sup>

Member of:

**cia**<sup>®</sup>

Technical Data		
	CAN 400-1	CAN 400-2
Dimensions (D x W x H mm)	290 x 210 x 25	290 x 210 x 25
Weight	Approx. 900 g	Approx. 900 g
<b>Power supply</b>		
Voltage	DC +5 V via backplane bus	DC +5 V via backplane bus
Current consumption	560 mA	600 mA
<b>CAN interfaces</b>		
Number	1	2
Type	ISO/DIN 11898-2 CAN High Speed physical Layer	ISO/DIN 11898-2 CAN High Speed physical Layer
Transmission rate	10 kbps to 1 Mbps	10 kbps to 1 Mbps
Protocol	CAN 2.0A (11 Bit) CAN 2.0B (29 Bit) CANopen <sup>®</sup> Master CANopen <sup>®</sup> Slave SAE J1939	CAN 2.0A (11 Bit) CAN 2.0B (29 Bit) CANopen <sup>®</sup> Master CANopen <sup>®</sup> Slave SAE J1939
Connection	SUB-D connector, 9-way	2 x SUB-D connector, 9-way
Status signal	6 LEDs	10 LEDs
<b>Configuration interfaces</b>		
Type	USB 1.1	USB 1.1
Connection	USB B-female	USB B-female
Ambient temperature	0 °C ... 60 °C	0 °C ... 60 °C
Transport and storage temperature	-25 °C ... 75 °C	-25 °C ... 75 °C

## DP/CAN Coupler CANopen®



DP/CAN Coupler CANopen®

The DP/CAN coupler links CANopen® devices into a PROFIBUS-DP network.

The DP/CAN coupler is a full-function CANopen® Master. It supports network management, SYNC telegrams and nodelocking for monitoring the nodes.

On the PROFIBUS-DP, the DP/CAN coupler is a normal node. The IO data of the CANopen® nodes are placed on the PROFIBUS in a transparent and freely configurable way.

The DP/CAN coupler is linked into the hardware configuration software via a GSD file and can be configured completely there. Further tools are not necessary.

On the PROFIBUS all standard baud rates up to 12Mbps are supported; on the CAN bus, up to 1Mbps.

The PROFIBUS address is set via a DIP switch.

Parameterization of the CANopen® nodes via SDO telegrams and management of emergency messages is also possible.

Alternatively the DP/CAN coupler can also be used as a CAN Layer 2 device on the CAN bus. This enables the connection of customer-specific CAN protocols via the PROFIBUS, too.

The DP/CAN coupler is intended for mounting on the DIN sectional rail and requires a 24V power supply. Because of its small width it fits even into the smallest cabinets.

### Features

- Up to 15 CANopen® participants
- Up to 1 Mbps CAN-baud rate
- Up to 12 Mbps PROFIBUS-DP
- Address setting via DP switch
- Simple configuration via GSD file
- CANopen® Master and CAN Layer 2 possible
- Address and function settable via dip switches
- 3 status LEDs
- Extended ambient temperature range

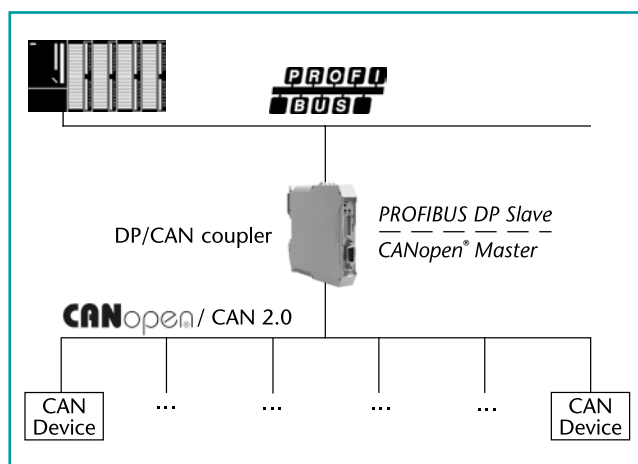

Application example DP/CAN Coupler CANopen®

### Ordering Data

	Order No.
DP/CAN coupler CANopen® (incl. manual, CD with software)	700-650-CAN01

### Technical Data

Dimensions (D x W x H mm)	114 x 18 x 108
Weight	Approx. 110 g
<b>Power supply</b>	
Voltage	24 V
Current consumption	Approx. 180 mA
<b>CAN interfaces</b>	
Type	ISO/DIN 11898-2 CAN High Speed physical Layer
Transmission rate	10 kbps to 1 Mbps
Protocol	CANopen® Master CAN 2.0A (11 Bit)
Connection	Clamp, 3-way
Status display	3 LEDs
<b>Configuration interfaces</b>	
Transmission rate	max. 12 Mbps, autodetection
Protocol	PROFIBUS-DP to EN 50 170
Connection	SUB-D female, 9-way
Ambient temperature	-25 °C ... 70 °C
Transport and storage temperature	-40 °C ... 75 °C
Relative humidity	max 80% at +20 °C, non- condensing
Degree of protection	IP 20

## DP/CAN Coupler Layer 2



DP/CAN Coupler Layer 2

The DP/CAN coupler layer 2 of Systeme Helmholtz GmbH allows you to connect any number of CAN nodes to the PROFIBUS-DP. The DP/CAN coupler layer 2 must be parameterized in the hardware configurator as a PROFIBUS node. The GSD files required for this purpose are supplied with the device.

The PROFIBUS side is configured as a DP slave. The interfaces meets EN 50170 and are electrically isolated. Baud rates of 9.6 kbps to 12 Mbps are automatically detected. The size of the input and output information is up to 320 Bytes.

The CAN bus interface meets ISO/DIN 11898-2 and is electrically isolated.

The DP/CAN coupler can send and receive any number of CAN messages. Messages can be defined with a fixed identifier, whose data are always visible in the PROFIBUS as an I/O image. Alternatively the DP/CAN coupler layer 2 can be equipped with a receive buffer for any number of CAN messages.

## Features

- Up to 1 Mbps CAN baud rate
- Up to 12 Mbps PROFIBUS-DP
- Address setting via DP switch
- Simple configuration via GSD file
- Any protocols possible via layer 2
- CAN 2.0 A (11Bit)
- CAN 2.0 B (29 Bit)
- Timer for cyclic telegrams
- 3 Status LEDs
- Extended ambient temperature range

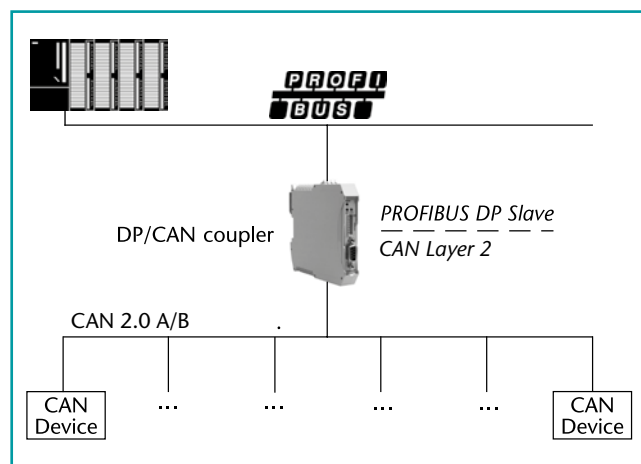

Application example DP/CAN Coupler Layer 2

Technical Data	
Dimensions (D x W x H mm)	114 x 18 x 108
Weight	Approx. 110 g
<b>Power supply</b>	
Voltage	24 V
Current consumption	Approx. 180 mA
<b>CAN interfaces</b>	
Type	ISO/DIN 11898 -2 CAN High Speed physical Layer
Transmission rate	10 kbps to 1 Mbps
Protocol	CAN 2.0A (11 Bit) / CAN 2.0B (29 Bit)
Connection	Clamp, 3-way
Status display	3 LEDs
<b>Configuration interfaces</b>	
Transmission rate	max. 12 Mbps, autodetection
Protocol	PROFIBUS-DP to EN 50 170
Connection	SUB-D female, 9-way
Ambient temperature	-25 °C ... 70 °C
Transport and storage temperature	-40 °C ... 75 °C
Relative humidity	max 80% at +20 °C, non- condensing
Degree of protection	IP 20

## Ordering Data

	Order No.
DP/CAN Coupler Layer 2 (incl. manual, CD with software)	700-651-CAN01

## CAN Software

### Parameterization Tool CANParam

The CAN modules are parameterized on the PC using the CANParam parameterization tool (contained in the 800-600-1AA11 software package). That makes setting the communication parameters easy. The parameterization of a module can be stored in a project on the PC.

The CAN modules support both the protocol format CAN 2.0A (11 Bit) and CAN 2.0B (29 Bit).

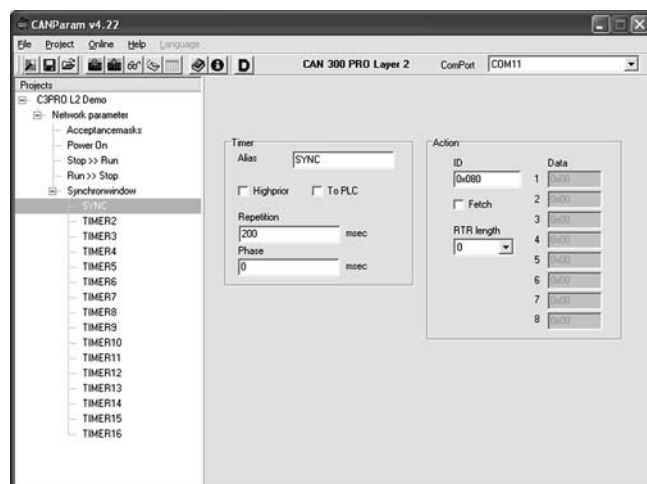

The CAN modules contain acceptance masks. These masks can be used to enable or disable various telegram IDs for reception. Express masks filter high-priority CAN telegrams so that they can be forwarded directly to the PLC.

For time-dependent events, such as the SYNC telegram in the case of CANopen®, up to 11 timers (CAN 300) or 16 timers (CAN 400) are available in the CAN modules up to a resolution of 1ms. Each timer can transmit any CAN telegram. The timers can be started, stopped, and changed from the PLC.

The timer 0 can also be used for synchronized transmission of CAN telegrams. It defines the time window in which all data will be transmitted synchronously.

CAN telegrams can be transmitted or timers started via freely programmable scripts on certain events such as “Power ON” or “PLC Stop -> Run”.

An integrated diagnostic function facilitates troubleshooting on commissioning of the module.

For CAN 300 PRO's CANopen® Master Function it's both possible to define the masters properties as to parameterize the slaves existing on the CAN bus.

In order to facilitate projection EDS-files can be read from CANopen® Slaves by CANParam Software.

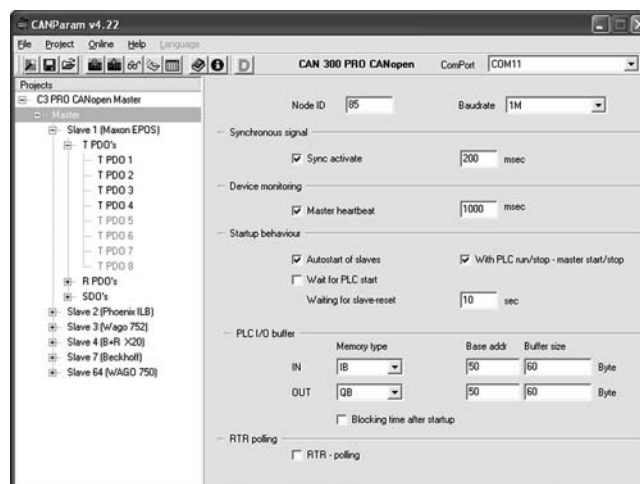

### Handling blocks

The CAN module is entered in the hardware configuration of the programming software as a CP- module (CAN 300, CAN 300 PRO) or an FM-module (CAN 400) and addressed in the STEP<sup>1)</sup>7 program via handling blocks.

For the CAN modules, handling blocks are available for layer 2 communication and for CANopen® Master (DS301 V4). If CAN modules are to be used as a CANopen® Slave, data handling functions are available for the profiles DS401 (IO modules) and DS420 (Corrugator). Further profiles can be set up on request.

#### Function scope of layer 2 data handling function:

- Transmit CAN telegram
- Read CAN telegram from the module
- Transmit CAN telegram to a timer
- Timer start/stop
- module reset

Various CAN protocols in 11 Bit or 29 Bit mode can be implemented with the handling blocks for layer 2.

#### Function scope of the CANopen® Master data handling function:

- Read SDO
- Transmit SDO
- SDO segmented download
- SDO segmented upload
- Spontaneous receive (NMT,PDO, Emergency)
- Transmit PDO
- Request PDO
- Nodeguarding/Heartbeat
- Network management

Application examples for controlling drives according to the DS402 profile are also supplied.

Furthermore handling blocks are available to utilize CAN 300 PRO as DeviceNet Slave.

Ordering Data	
	Order No.
<b>Handling blocks for CAN</b> CD with parameterization software “CANParam”, handling blocks “Layer 2”, “CANopen®” and “SAE J1939” <b>CANopen® Slave handling blocks</b> <b>Devicenet Slave handling blocks</b>	<b>800-600-1AA11</b>  <b>on request</b> <b>on request</b>
<b>CAN Trainig Course</b> (see page 124)	<b>400-600-CAN01</b>

1) STEP is a registered trademark of Siemens AG



## CAN Bus Connector

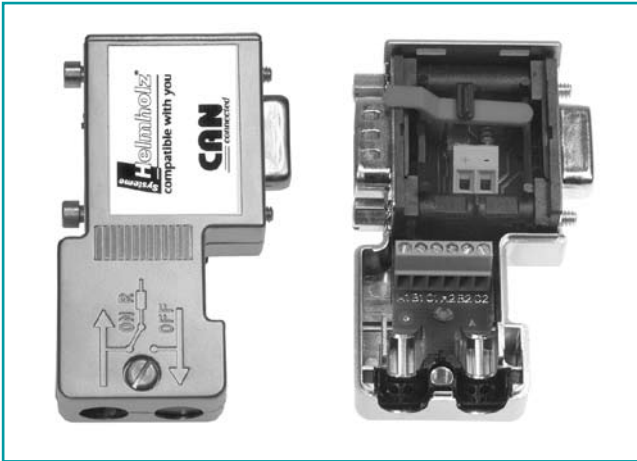

CAN bus connector, 90° cable outlet



CAN bus connector, axial

The bus connectors for CAN bus are used to connect a CAN bus station to the CAN bus cable. The connector is quickly mounted and has integrated, connectable terminating resistors. The Systeme Helmholtz GmbH offers the bus connector with a vertical outgoing cable and for transmission rates up to 1 Mbps. The bus connector is plugged directly onto the CAN bus interface (SUB-D-connector, 9-way) of the CAN bus stations. The CAN bus cables are connected using 6-way screw terminals. Using a slide switch, you can set whether the connector is to be used as a node or segment end. The switch can also be operated when the connector is installed. The setting can be clearly seen. The connector must be operated in node setting ("OFF") when the incoming bus and the outgoing bus are to be interconnected. The terminating resistors are then bypassed. The connector must be set as a segment end ("ON"), on the first and last (extreme) stations of the segment. In that case the terminating resistors are connected on the incoming bus, the outgoing bus is disconnected. The bus connectors for CAN are also available with axial cable outlet and 24 V for user supply.

### Features

- 24 V for user supply (only for 90°)
- Metalized housing
- No loosable parts
- 90° and axial cable outlet available
- Small housing

**CAN**  
connected

**cia**

Member of:

Ordering Data	
	Order No.
CAN Bus Connector 90° without additional connection jack	700-690-1BA12
CAN Bus Connector 90° with additional connection jack	700-690-1BB12
CAN Bus Connector axial	700-690-0CA12

Technical Data	
<b>Connection jack</b> Order No. 700-690-1BB12 Order No. 700-690-1BA12 Order No. 700-690-0CA12	<b>Yes</b> <b>No</b> <b>No</b>
Dimensions (D x W x H mm) 700-690-1BB12/690-1BA12 700-690-0CA12	65 x 48 x 16 67.5 x 35 x 17
Weight	Approx. 40 g
Terminating resistor	Resistance 120 Ω; integrated and connectable with slide switch
Transmission rate max.	1 Mbps
<b>Interfaces</b> CAN bus station	SUB-D connector, 9-way
CAN bus cable	6 terminals for wires up to 0.5 mm <sup>2</sup>
Max. outside diameter	8.0 mm
Ambient temperature Transport and storage temperature	0 °C ... +60 °C -25 °C ... +75 °C
Relative humidity max.	75% at +25 °C
Degree of protection	IP 20

## CAN Bridge, connecting CAN networks



CAN Bridge

CAN bus systems have become widely distributed in automation technology and are also being used more and more frequently in complex applications.

The CAN Bridge from Systeme Helmholtz GmbH enables the coupling of two CAN networks of the same or different types.

Thereby, the CAN Bridge can operate both as message repeater for increasing the network expansion as well as connecting different CAN networks with each other. It is not significant thereby whether the CAN networks have different baud rates or operate with different protocols, e.g. CANopen® and a proprietary protocol.

A flexible, configurable filtering logic can adopt freely selectable identifiers and implement on the other network. The CAN messages are forwarded to the respective other network according to the Store-Forward principle and sent out again.

Using the CAN Bridge, the CAN networks are both physically decoupled (electrical isolation) as well as reducing the bus load on both CAN networks. The CAN Bridge enables a flexible design of the network topology; star and tree structures can also be implemented as expanded line structures.

The CAN Bridge can be configured for simple applications using the two rotary encoding switches. In the case of more complex applications, the filtering and forwarding of the CAN telegrams can be flexibly adjusted using the supplied CAN Bridge configuration software. Up to 256 range filters and up to 4 bit filters for address filtering are available. The configuration is read in using a USB port and can also be read out again.

The CAN Bridge operates both in 11-bit as well as 29-bit mode and can communicate with baud rates of 10 Kbaud up to 1 Mbaud. It has a powerful micro controller which can also operate at the highest data rates and bus loads without loss of the messages. 5 LEDs signal the status of the device and the connected CAN networks.

### Ordering Data

	Order No.
<b>CAN Bridge</b> 2 x CAN bus interfaces (incl. software and USB programming cable)	700-660-2AA01

### Features

- 11 bit/29 bit
- Bit filter/range filter
- Autobaud detection
- 10 Kbaud ... 1 Mbaud
- Easy configuration mode
- Electrical isolation of the CAN networks
- Can be used with CAN 2.0A & 2.0B, CANopen®, DeviceNet, SAE J1939
- CAN bus according to ISO 11898-2
- DIN rail mounting

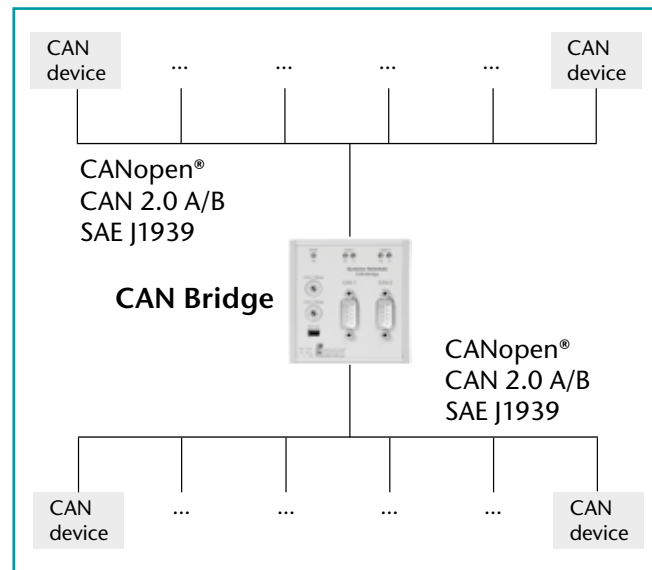

### Technical Data

Dimensions in mm (D x W x H)	31 x 74 x 75
Weight	Approx. 130 g
<b>Power supply</b>	
Voltage	18 - 30 V DC
Current consumption	typ. 35 mA max. 60 mA
<b>CAN interfaces</b>	
Type	2 x ISO/DIN 11898-2 CAN High Speed physical Layer
Transmission rate	10 kbps up to 1 Mbps
Protocol	CAN 2.0A (11 Bit) CAN 2.0B (29 Bit) CANopen® SAE J1939 DeviceNet
Connection	2 x Connector, SUB-D, 9-way
Status display	5 LEDs
<b>Configuration interfaces</b>	
Type	USB 1.1
Connection	Mini USB socket
Ambient temperature	-25 °C ... 60 °C
Transport and storage temperature	-25 °C ... 75 °C



# Interface Converters

FO Converter  
Programming Adapter  
Accessory  
RK512- and HMI-Adapter

## OPTopus, PROFIBUS Optical Link



OPTopus, PROFIBUS Optical Link

The new OPTopus PROFIBUS Optical Link from Systeme Helmholtz GmbH is a full PROFIBUS repeater with an integrated FO interface. The OPTopus permits transmission rates of 9.6 kbps to 12 Mbps on the PROFIBUS with automatic detection of the baud rate. With its optical signal transmission, it offers complete electrical isolation between the PROFIBUS stations and PROFIBUS subnetworks. A further advantage of the OPTopus is its insensitivity to EMC influences.

Because of its compact design, no additional space in the control cabinet is required for deployment because the OPTopus PROFIBUS Optical Link can be used instead of a PROFIBUS connector and is simply plugged into a station in the PROFIBUS network. Moreover, no separate power supply is required because the OPTopus uses the 5 V power supply that every PROFIBUS device provides for the terminating resistor.

The transmission signals are converted into optical signals by the OPTopus and are transmitted on the FO line in this way. The signals are also regenerated with their edge steepness, level and mark-to-space ratio. The OPTopus PROFIBUS is available with 3 different optical interfaces and can therefore also be perfectly combined with existing transmission systems. It is suitable for POF<sup>1)</sup> and PCF<sup>2)</sup> FO. For the close range up to 65 m, an optical transmission line can be set up very quickly and without great effort using POF. The scope of supply of the OPTopus contains the appropriate connectors for this purpose. Only a standard POF FO is additionally required. For larger distances up to 250 m, PCF-FOs can be used. The optical interface of the OPTopus transmits in the visual range (650 nm red light), which enables initial checking of the optical transmission line without expensive measuring instruments.

For many applications, the OPTopus PROFIBUS Optical Link is a real alternative to conventional optical signal converters, both technically and in terms of price. It additionally provides the advantages of a normal repeater. Bus extension, increase in the number of stations and expansion of your plant. Use in MPI networks is also possible.

As a special application, the PROFIBUS Optical Link permits the building of spur lines as autonomous segments.

For this purpose, it can be plugged into programming device port of an existing PROFIBUS connector.

The OPTopus PROFIBUS Optical Link for diagnostic purposes provides a traffic LED and an error LED for the PROFIBUS, and for the optical interface. These keep you informed at all times about the bus status and ensure targeted troubleshooting.

## Features

- PROFIBUS baud rate (9.6 kbps to 12 Mbps), autodetect
- Compact design, not larger than a Helmholtz PROFIBUS connector
- LED display of traffic/bus errors separately for FO and PROFIBUS segment
- Switchable terminating resistor with optical display
- Complete electrical isolation
- Insensitive to EMC influences
- No 24 V power supply required
- Powered directly with 5 V through the PROFIBUS station
- Available with 3 different optical interfaces (SMA, BFOC, Versatile Link plug-in system)
- Suitable for POF<sup>1)</sup> and PCF<sup>2)</sup> FO
- Range: Cable length POF<sup>1)</sup> 65 m  
Cable length PCF<sup>2)</sup> 250 m
- FO plug-in connector supplied

There is also a power LED that provides information about the operating status and status of the terminating resistors.

Technical Data	
Dimensions in mm (D x W x H)	Approx. 64 x 40 x 17
Weight	Approx. 40 g
<b>Power supply</b>	
Voltage	+ 5 V DC
Current consumption	typ. 100 mA
Connector socket	SUB-D 9-polig
<b>PROFIBUS interface</b>	
Transmission rate	9.6 kbps to 12 Mbps detected automatically
Protocol	PROFIBUS-DP acc. to EN 61 158-2
Connection	Socket, SUB D, 9-way
<b>Optical interface</b>	
Wavelength	650 nm
Numerical aperture transmit diode	0,50
Launchable optical power/ receiver sensitivity	
POF 980/1000 µm	-7,5 dBm/-20 dBm
PCF 200/230 µm	-18 dBm/-22 dBm
Overdrive limit receiver	-3 dBm
Max. transmission distance	
POF 980/1000 µm (160 dB/km)	Up to 65 m
PCF 200/230 µm (10 dB/km)	Up to 250 m
Ambient temperature	0 °C ... +60 °C
Transport and storage temperature	-25 °C ... +75 °C
Degree of protection	IP 20

OPTopus, PROFIBUS Optical Link

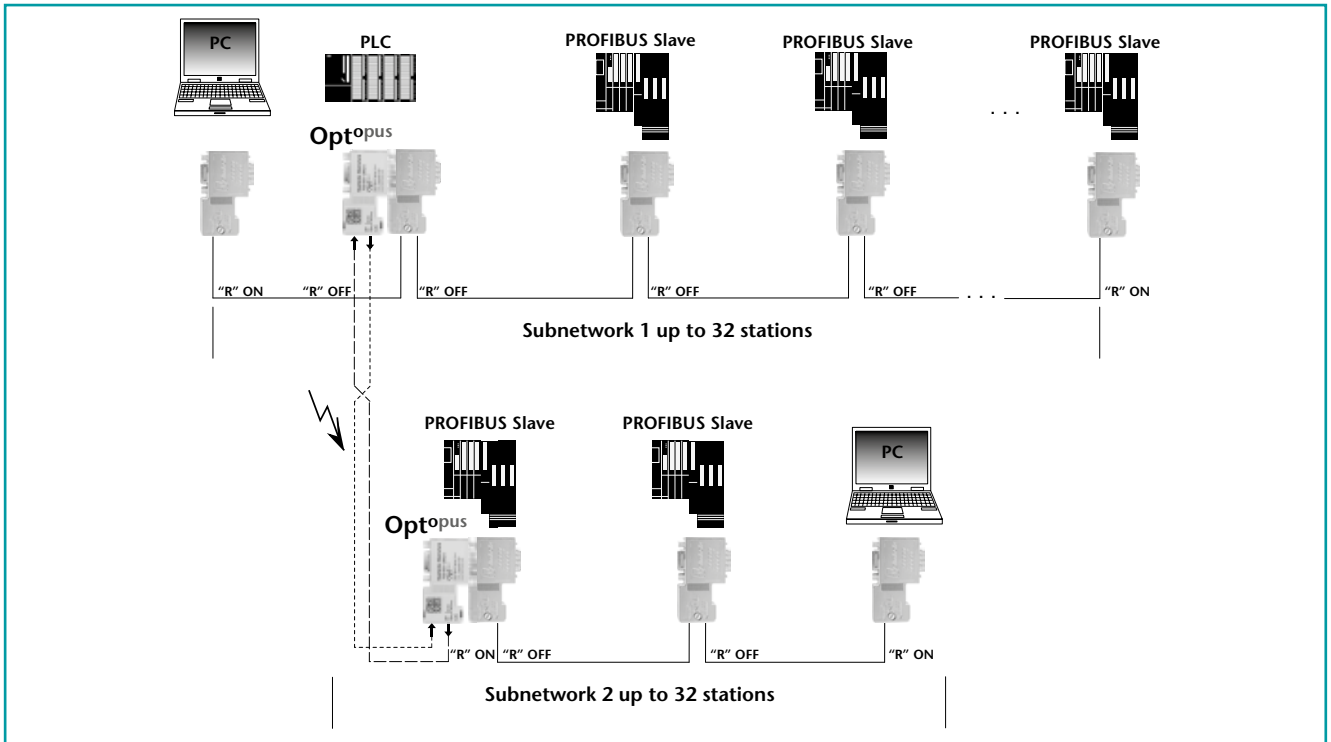

Generation of a completely electrically isolated subnetwork.

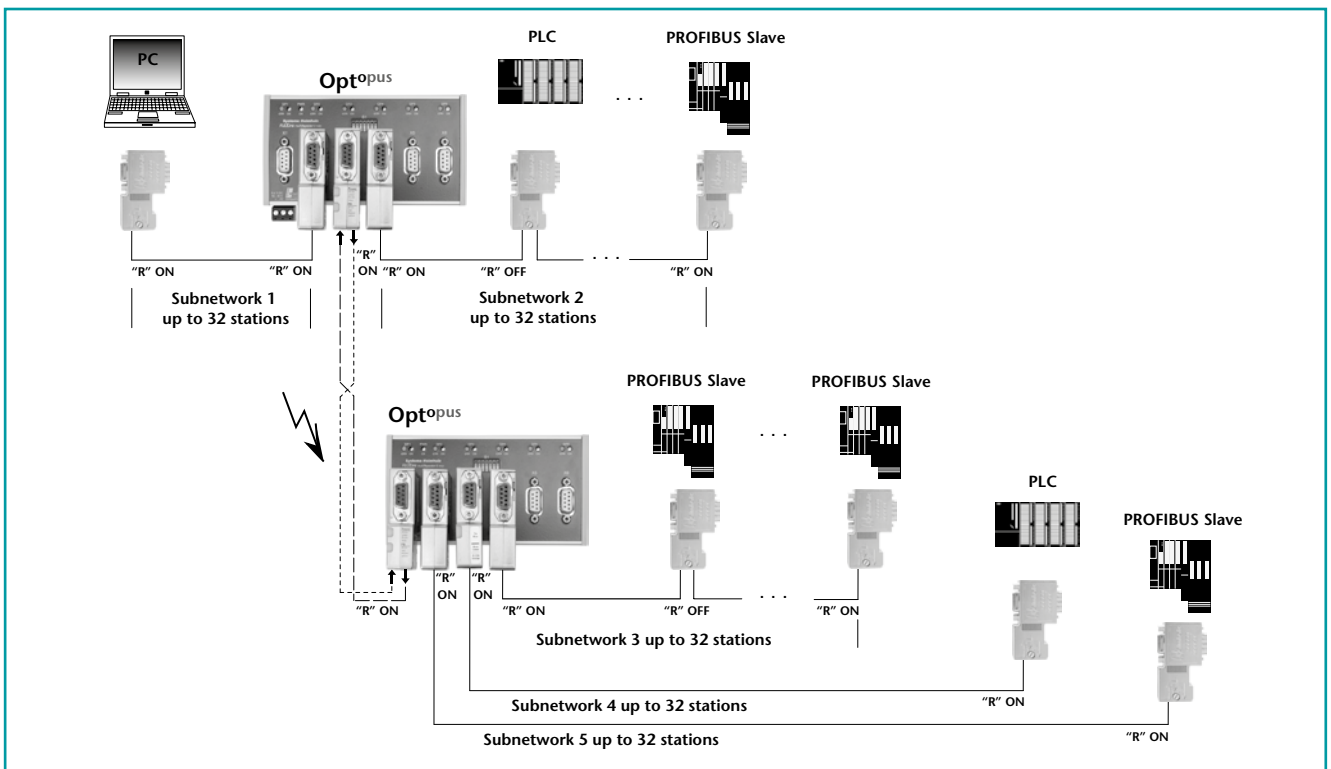

Establishment of a link between two repeaters that is not subject to EMC interference.

Ordering Data	
	Order No.
OPTopus, PROFIBUS Optical Link Versatile Link (incl. plug-in connector and instruction)	700-991-1AA01
BFOC (incl. plug-in connector and instruction)	700-992-1AA01
SMA (incl. plug-in connector and instruction)	700-993-1AA01

- 1) Polymeric-optical-fiber
- 2) Polymer-cladded-fiber

## SSW7, MPI-Programming Adapter



SSW7, MPI-Programming Adapter

The SSW7 permits connection of a PC or laptop with programming software to programmable controllers via any standard COM port.

The RS232 interface of the SSW7 has automatic baud rate detection for adaptation to the set baud rate (between 9.6 to 115 kbps). The MPI interface operates with 187.5 kbps or 19.2 kbps.

The SSW7 receives its voltage supply from the CPU via the MPI bus. With an optional 24 V connection it can be used anywhere else in the system.

With the included speed-up tool you can attain the max. transmission rate of the SSW7 with every programming software.

**Accessory-Note**

DIN rail adapter, extension cables (on request) as well as multiplexers (see page 106) are available for the SSW7.

By using SHTools software parameterization and diagnostic functions are possible. For firmware update a free download of the latest SHTools version is available on our website [www.helmholz.com](http://www.helmholz.com).

Ordering Data	
	Order No.
<b>MPI-Adapter SSW7, RS232</b> (incl. 3 m programming cable, manual, CD with software)	700-751-1VK21
<b>SSW7, RS422</b> (incl. manual, CD with software)	700-752-1VK21
<b>DIN rail adapter short Power Plug</b> (optional)	700-751-HSH01 700-751-SNT01

**Features**

- Programming and visualization
- Transmission rate up to 115 kBAud
- MPI up to 187,5 kbps
- Power supply via programming device or via external 24 V supply

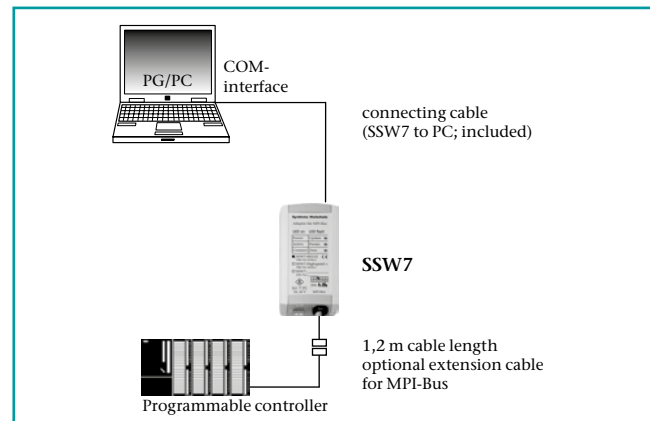

Application example for SSW7

Technical Data	
Dimensions (D x W x H mm)	105 x 53 x 29
Weight	Approx. 180 g
Supply voltage	+24 V ±25 % from PLC or extern
Current consumption	typ. 30 mA max. 45 mA
<b>MPI-Interface</b>	
Type	RS485
Transmission rate	19.2 or 187.5 kbps
Cable connector	SUB-D, 9-way
<b>Communication interface</b>	
Type	RS232/RS422
Transmission type	Serial asynchronous
Transmission rate	19.2 kbps to 115.2 kbps
Parity	odd
Data format	8 Bit
Protocols	PC <-> S7
Connection	Connector, SUB-D, 9-way
Degree of protection	IP 20

## SSW7-USB, MPI-Programming Adapter USB



SSW7-USB, MPI-Programming Adapter USB

The SSW7-USB permits conversion from a USB interface to the MPI bus for programming software or visualization. The SSW7 has a 1.2 m long MPI connecting cable, which can be directly plugged into the CPU socket of the programmable controller or at any other point in the MPI network. The housing of the SSW7-USB contains a type "B" USB socket. The SSW7-USB can be connected to the PC via the USB cable supplied. The SSW7-USB is powered from the PC. The SSW7-USB can therefore be used at any point in the MPI bus. A driver for creating a virtual COM-port is included.

**Accessory-Note**

DIN rail adapter, extension cables (on request) as well as multiplexers (see page 106) are available for the SSW7-USB.

By using SHTools software parameterization and diagnostic functions are possible. For firmware update a free download of the latest SHTools version is available on our website [www.helmholz.com](http://www.helmholz.com).

**Features**

- Programming and visualization via USB
- MPI up to 187,5 kbps
- Supply Voltage via USB
- Virtual COM-port for flexible applications

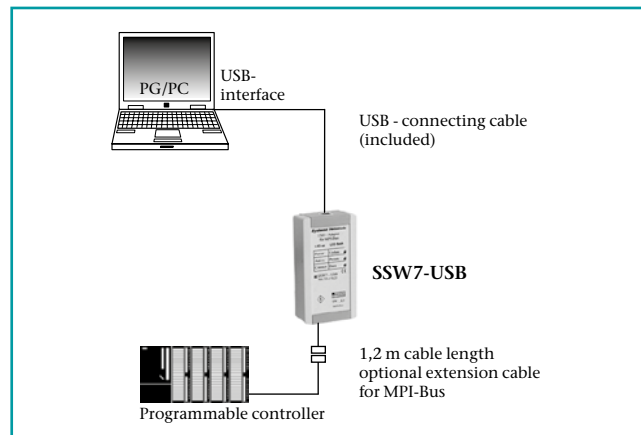

Application example for SSW7-USB

Ordering Data	
	Order No.
MPI-Adapter SSW7-USB (incl. 3 m USB cable, manual, CD with software)	700-755-1VK21
DIN rail adapter short	700-751-HSH01

Technical Data	
Dimensions (D x W x H mm)	105 x 53 x 29
Weight	Approx. 180 g
Supply voltage	5 V via USB
Current consumption	Approx. 150 mA
<b>MPI interface</b>	
Type	RS485
Transmission rate	19.2 or 187.5 kbps
Cable connector	SUB-D, 9-way
<b>Communication interface</b>	
Type	USB 1.1
Protocols	PC <-> S7
Connection	USB-B female
Degree of protection	IP 20

## SSW7-RK512, SSW7-HMI, MPI-Adapter with RK512/HMI Protocol

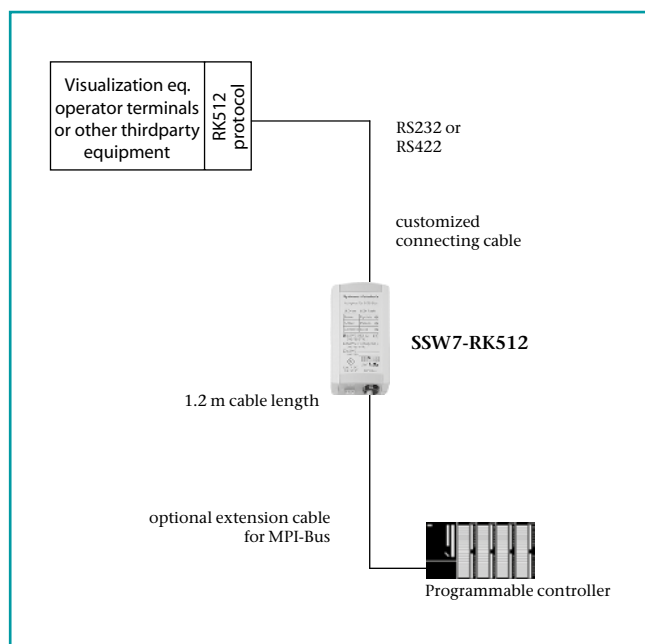

SSW7-RK512

**SSW7-RK512**

With the SSW7-RK512 you can connect any operator terminal, visualization equipment, or other third-party equipment to the S7 without adapting the software, if they support the RK512 protocol.

The SSW7-RK512 transmits data blocks, flags, inputs and outputs. The MPI settings of the SSW7-RK512 can be changed with a parameterization program or with special RK512 frames in order to connect several SSW7-RK512s or several PLCs to an MPI bus. The RS232 interface of the SSW7-RK512 has automatic baud rate detection for adapting itself to the connected device (between 9.6 and 115 kbps). The MPI interface operates with 187.5 kbps. The voltage supply for the SSW7-RK512 is taken from the CPU via the MPI bus. With an optional 24 V connection it can be operated anywhere else in the system.

We supply the SSW7-RK512 with an additional programming interface on the connector including switchable terminating resistor.

**Accessory-Note**

DIN rail adapter, extension cables (on request) as well as multiplexers (see page 106) are available for the SSW7-RK512.

By using SHTools software parameterization and diagnostic functions are possible. For firmware update a free download of the latest SHTools version is available on our website [www.helmholz.com](http://www.helmholz.com).

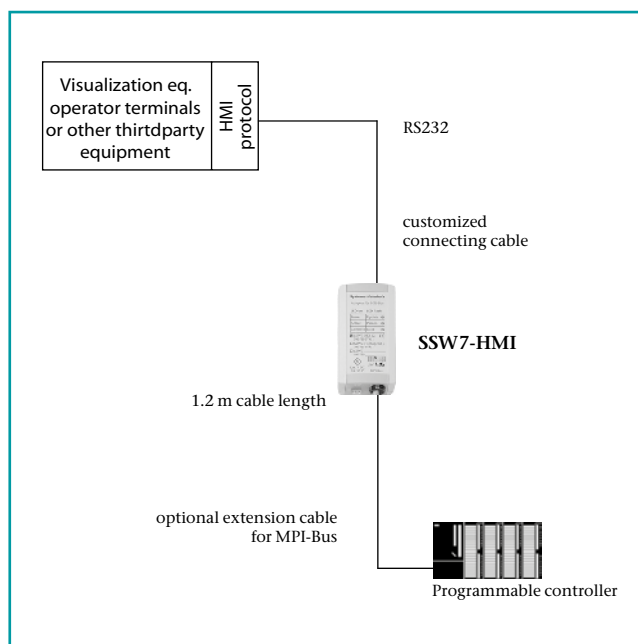

SSW7-HMI

**SSW7-HMI**

The SSW7-HMI is intended for use with operator terminals, visualization equipment or other third-party equipment that supports the Siemens HMI protocol.

The baud rate of the adapter is set by the protocol (between 9.6 and 115 kbps).

The voltage supply for the SSW7-HMI is taken from the CPU via the MPI bus. With an optional 24 V connection it can be operated anywhere else in the system.

We supply the SSW7-HMI with an additional programming interface on the connector including switchable terminating resistor.

**Accessory-Note**

DIN rail adapter, extension cables (on request) as well as multiplexers (see page 106) are available for the SSW7-HMI.

By using SHTools software parameterization and diagnostic functions are possible. For firmware update a free download of the latest SHTools version is available on our website [www.helmholz.com](http://www.helmholz.com).

**Ordering Data**

	Order No.
<b>MPI-Adapter</b> SSW7-RK512 (incl. manual) SSW7-RK512 with RS422 interface (incl. manual)	700-751-5VK21 700-752-5VK21
<b>DIN rail adapter short</b> <b>Power Plug</b> (optional)	700-751-HSH01 700-751-SNT01

**Ordering Data**

	Order No.
<b>MPI-Adapter</b> SSW7-HMI (incl. manual)	700-751-9VK21
<b>DIN rail adapter short</b> <b>Power Plug</b> (optional)	700-751-HSH01 700-751-SNT01



## SSW7-RK512, SSW7-HMI, MPI-Adapter with RK512/HMI Protocol

Technical Data			
	SSW7-RK512	SSW7-RK512 with RS422	SSW7-HMI
	700-751-5VK21	700-752-5VK21	700-751-9VK21
Dimensions (D x W x H mm)	105 x 53 x 29	105 x 53 x 29	105 x 53 x 29
Weight	Approx. 180 g	Approx. 180 g	Approx. 180 g
Supply voltage (from AG or current supply)	+24 V ±25 %	+24 V ±25 %	+24 V ±25 %
Current consumption	Approx. 70 mA	Approx. 70 mA	Approx. 70 mA
<b>MPI-Schnittstelle</b> Type	RS485	RS485	RS485
Transmission rate	187.5 kbps	187.5 kbps	19.2 or 187.5 kbps
Cable connector	SUB-D, 9-way with PG interface and witerminating resistor	SUB-D, 9-way with PG interface and witerminating resistor	SUB-D, 9-way with PG interface and witerminating resistor
<b>Communication interface</b> Type	RS232	RS422	RS232
Transmission type	Serial asynchronous	Serial asynchronous	Serial asynchronous
Transmission rate	19.2 ... 115.2 kbps	19.2 ... 115.2 kbps	4.800 ... 115.2 kbps
Parity	Even	Even	Odd
Data format	8 Bit	8 Bit	8 Bit
Protocols	RK512 with 3964/R	RK512 with 3964/R	HMI
Connection	Connector, SUB-D, 9-way	Connector, SUB-D, 9-way	Connector, SUB-D, 9-way
Degree of protection	IP 20	IP 20	IP 20

## Multiplexer for MPI and PROFIBUS



Multiplexer for MPI-/PROFIBUS

The MPI/PROFIBUS multiplexer permits connection of up to 3 devices to one MPI or PROFIBUS network. The MPI/PROFIBUS multiplexer has a 1.2 m long connecting cable that can be plugged directly into the MPI/PROFIBUS socket of the PLC but also at any position in an MPI or PROFIBUS network. The "PG" socket is the only socket that has the full MPI pin assignment. That makes it possible to use "direct operation" on this socket via an MPI adapter ("SSW 7" or "PC adapter") with programming software. This pin assignment is not relevant for operation of PROFIBUS devices. The MPI/PROFIBUS multiplexer is powered via the connection line from the CPU. If the terminal does not provide 24 V, it is possible to draw the 24 V from an external source.

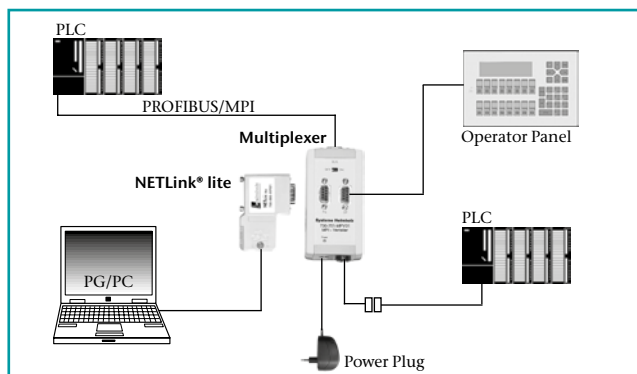

Application example for MPI Multiplexer



Ordering Data	
	Order No.
Multiplexer for MPI/PROFIBUS (incl. instruction)	700-751-MPV01
Power Plug (optional)	700-751-SNT01

Technical Data	
Dimensions (D x W x H mm)	125 x 67 x 30
Weight	Approx. 135 g
<b>Power supply</b>	
Voltage	DC 24 V
Current consumption	max. 200 mA at 24 V
<b>PROFIBUS interface</b>	
Transmission	max. 12 Mbps
Connection	3 x female, SUB-D, 9-way
Ambient temperature	0 °C ... +60 °C
Transport and storage temperature	-25 °C ... +75 °C
Degree of protection	IP 20



# Components for S5

Converter Cables

Memory Cards

RAM Submodules

EPROM, EEPROM

Digital Input/Output Modules

Analog Input/Output Modules

Serial Interface Modules

## SSW5/LAN, S5 Ethernet Converter



SSW5/LAN, S5 Ethernet Converter

The SSW5/LAN is an S5 Ethernet converter suitable for programming S5 controllers via the Ethernet. A special virtual COM-port driver enables the usage of common programming tools, e.g. STEP<sup>1)</sup> 5 V7.2 from Siemens. The power is drawn from the CPU or from an external source (24 V). A virtual COM port is available for all common installation tools.

## Features

- S5 programming via TCP/IP
- Virtual COM port for all common installation tools
- Power supply from the CPU or external 24 V
- Compatible with every common S5 CPU
- Clearly recognition in the network by device name

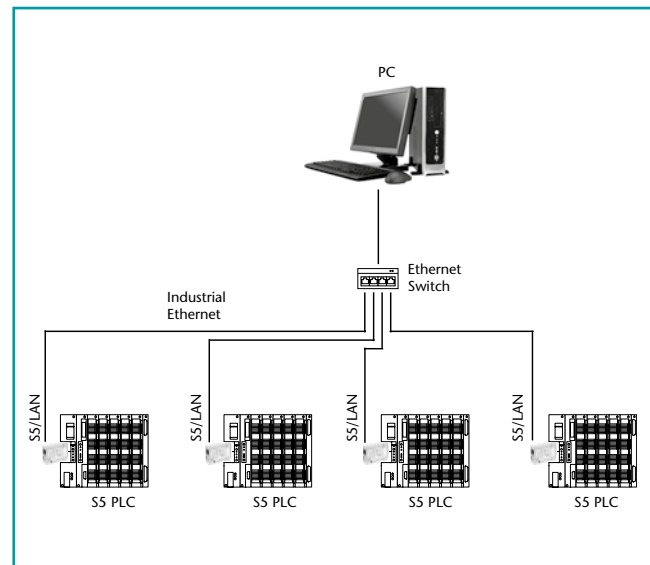

Application example SSW5/LAN

## Ordering Data

	Order No.
SSW5/LAN (incl. 3 m Ethernet cable, manual, CD with software)	700-750-LAN13

1) STEP is a registered trademark of Siemens AG.

## Technical Data

Dimensions (D x W x H mm)	65 x 21 x 42
Weight	Approx. 50 g
<b>Power Supply</b> Voltage	24 V DC via AG-interface or extern
Current consumption	Approx. 55 mA (typ.)
<b>S5-AG Interface</b> Type	TTY, 20 mA
Transmission rate	9.6 kBaud
Protocol	AS 511
Connection	15-way Sub-D connector
<b>Ethernet interface</b> Type	10 Base-T/100 Base-T; RJ45 female
Transmission rate	10/100 Mbps
Ambient temperature Transport and storage temperature	0 °C ... 60 °C -25 °C ... 75 °C
Degree of protection	IP 20

## SSW5/USB, Programming Cable



SSW5/USB programming cable

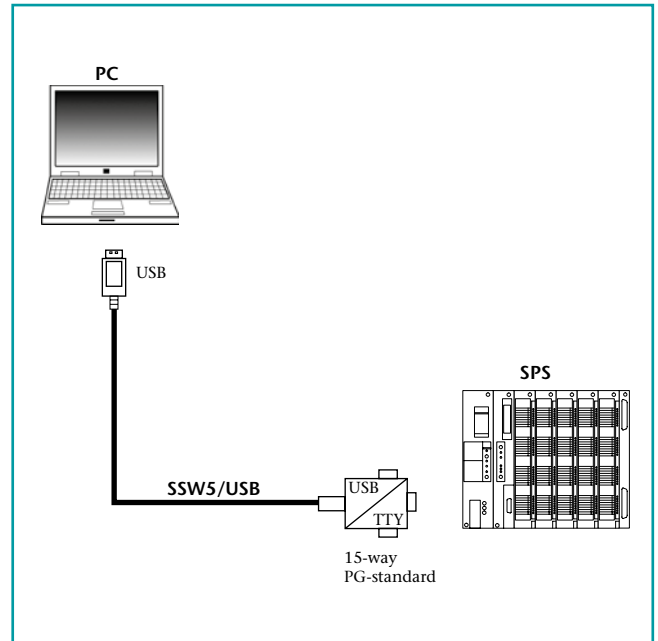

Application example SSW5/USB

The SSW5/USB programming cable enables a connection between a PC or Laptop via USB to an S5 PLC. A special virtual COM-port driver enables the usage of common programming tools, e.g. STEP<sup>1)</sup>5 V7.2 from Siemens. The SSW5/USB is equipped with a 15-pole Sub-D connector.

Ordering Data	
	Order No.
SSW5/USB, programming cable, length 3 m (incl. manual, CD with software)	700-750-0US13
SSW5/USB, programming cable, length 5 m (incl. manual, CD with software)	700-750-1US13

1) STEP is a registered trademark of Siemens AG.

Technical Data	
Conversion Interface	USB to TTY USB
Transmission	USB
TTY interface	SUB-D male connector, 15-way
Max. transmission rate	38400 Bps
Max. cable length	5 m
Source of supply voltage	USB-sided

## SSW3, RS232-TTY Converter Cable

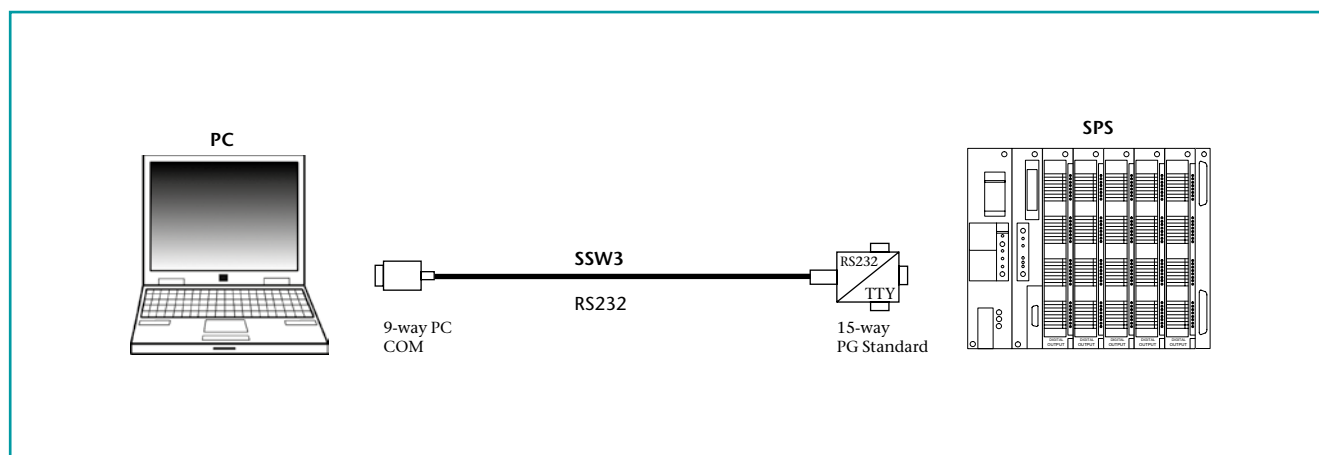

SSW3 interface converter cable

The SSW3 converter cable permits a connection between a PC and a PLC.

The RS232/TTY converter is completely integrated in the 15-way connector housing. An external power supply is therefore not required.

The data signals are transmitted via an **RS232** link.

**Application** in conjunction with:

- Any programming software on a PC
- Online link with the PLC with data exchange
- Visualization and communication software

Ordering Data	
	Order No.
<b>Interface converter cable</b>	
SSW3, length 5 m	700-750-0AA13
SSW3, length 10 m	700-750-1AA13
SSW3, length 15 m	700-750-2AA13

Technical Data	
Conversion	RS232 to TTY
Transmission	RS232
RS232 interface	SUB-D female connector, 9-way
TTY interface	SUB-D male connector, 15-way
Max. transmission rate	38400 Bps
Max. cable length	15 m
Source of supply voltage	PG

## SSW4, RS232-TTY Converter Cable

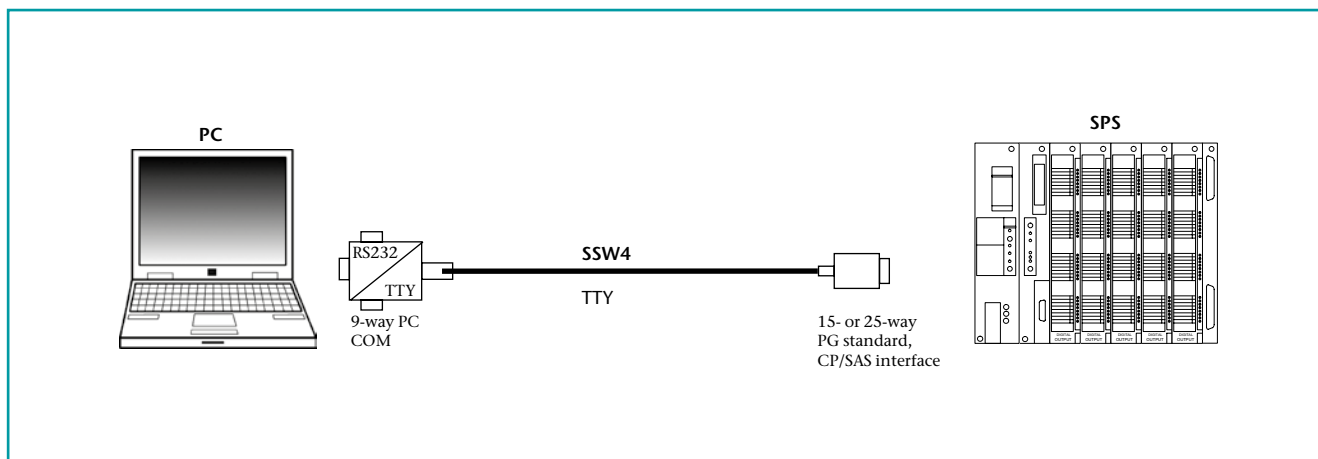

Interface converter cable SSW4

The SSW4 converter cable permits a connection between a PC and a PLC.

The RS232/TTY converter is completely integrated in the 9-way connector housing and ensures complete isolation. On the TTY side the SSW4 uses the current sources of the remote unit, the RS232 side is powered via the RS232 status signals. The software used must set the status line accordingly.

The data signals are transmitted through a TTY connection.

Because the electronics is housed in the 9-way connector housing, it is possible to make up customized connecting cables for various TTY assignments on request.

**Application** in conjunction with:

- Any programming software for PLC on a PC
- On-line link with the PLC for data exchange
- Visualization and communication software

Ordering Data	
	Order No.
<b>Interface converter cable</b>	
SSW4, length 5 m, 15-way	700-750-0AA24
SSW4, length 10 m, 15-way	700-750-1AA24
SSW4, length 15 m, 15-way	700-750-2AA24
SSW4, length 25 m, 15-way	700-750-3AA24
SSW4, length 50 m, 15-way	700-750-4AA24
SSW4, length 5 m, 25-way	700-750-0AA14
SSW4, length 10 m, 25-way	700-750-1AA14
SSW4, length 15 m, 25-way	700-750-2AA14
SSW4, length 25 m, 25-way	700-750-3AA14
SSW4, length 50 m, 25-way	700-750-4AA14
<b>Special lengths on request (up to 200m)</b>	
SSW4, 15-way	700-750-OSO24
SSW4, 25-way	700-750-OSO14

Technical Data	
Conversion	RS232 to TTY
Transmission	TTY
RS232 interface	SUB-D female connector, 9-way
TTY interface	SUB-D male connector, 15- or 25-way
Max. transmission rate	9600 Bps
Max. cable length	200 meters
Source of supply voltage	PC

## Memory Cards



Memory card, short type



Memory card, long type

Memory cards from the Systeme Helmholtz GmbH, suitable for the S5, are designed for use in CPU main memory and CP modules.

We have been able to achieve a very advantageous price performance ratio with the use of modern, high-quality manufacturing methods.

Our product program covers the range of the most common submodules.

Ordering Data	
	Order-Nr.
<b>Flash EPROM cards</b> short 5 V 128 kByte 256 kByte 512 kByte 1 MByte	700-374-1KG11 700-374-1KH21 700-374-1KJ11 700-374-1KK21
<b>Flash EPROM cards</b> long 5 V 128 kByte 256 kByte 1 MByte	700-374-2KG21 700-374-2KH21 700-374-2KK21
<b>RAM cards</b> long 256 kByte	700-374-2AH21

Technical Data	
<b>Flash EPROM Cards, short 5 V</b> Memory capacity	128 kByte 256 kByte 512 kByte 1 MByte
Applications	CPU 945
<b>Flash EPROM cards, long 5 V</b> Memory capacity	128 kByte 256 kByte 1 MByte
Applications	CPU 928 B
<b>RAM cards, long</b> Memory capacity	256 kByte
Applications	CP 581



## RAM Submodules

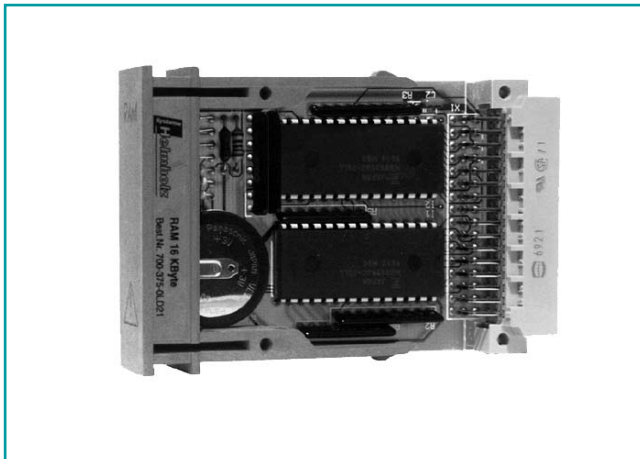

RAM submodule 375

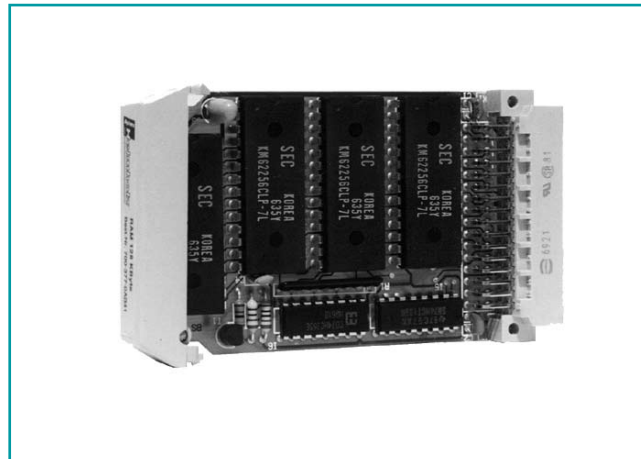

RAM submodule 377, long type

RAM submodules from the Systeme Helmholtz GmbH, suitable for the S5, are designed for use in CPU main memory and in WF and CP modules.

The RAM submodules, series 375 and series 377 (short type) feature a battery backup integrated into the submodule. The RAMs are even backed up while the submodule is removed from its slot. Unintentional removal of the submodule no longer results in loss of data. That often makes the use of EEPROM submodules unnecessary

Ordering Data	
	Order No.
<b>RAM submodules series 375</b> with battery 8 kByte 16 kByte 32 kByte	700-375-OLD11 700-375-OLD21 700-375-OLD31
<b>RAM submodules series 377</b> short type 16 kBytes without battery 32 kBytes without battery 64 kBytes without battery 64 kBytes with battery	700-377-0AA11 700-377-0AA21 700-377-0AA32 700-377-0BA31
<b>RAM submodules series 377</b> long type 32 kByte 64 kByte 128 kByte	700-377-0AB21 700-377-0AB31 700-377-0AB41

Technical Data	
<b>RAM submodules series 375</b> Memory capacity	8 kByte 16 kByte 32 kByte
Backup	3 V lithium battery
Applications	PLC 115, CP 530
<b>RAM submodules series 377</b> Short type with battery Memory capacity	64 kByte
Backup	3 V lithium battery
Applications	PLC 135
<b>RAM submodules series 377</b> Short type without battery Memory capacity	16 kByte 32 kByte 64 kByte
Applications	PLC 135
<b>RAM submodules series 377</b> Short type without battery Memory capacity	32 kByte 64 kByte 128 kByte
Applications	PLC 155, WF 470, CP 525, CP 526, CP 527

## EPROM, EEPROM

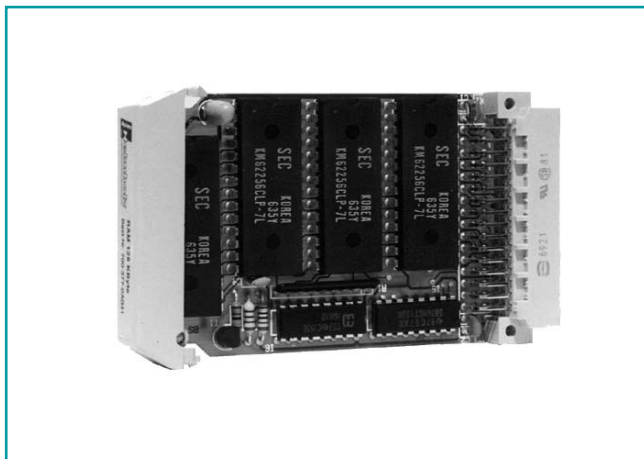

EPROM submodule 373

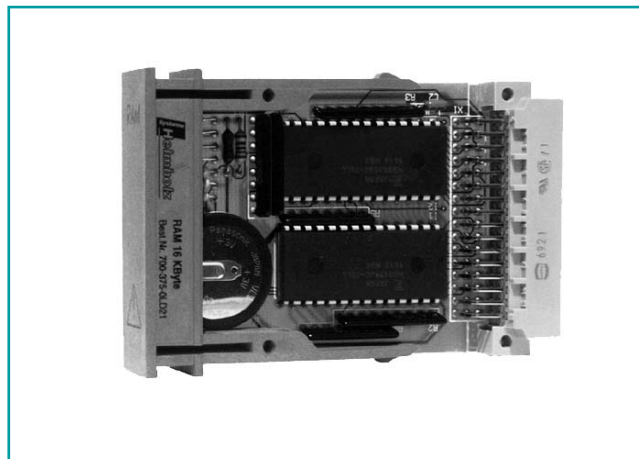

EPROM submodule 375

EPROM and EEPROM submodules from the Systeme Helmholtz GmbH, suitable for the S5, are designed for use in CPU main memories and in WF and CP modules.

All Helmholtz EPROM submodules with the ordering code -0LAxx or -0Axx can be programmed on all programmers, including the old PG 675/685.

These EPROM submodules use the tested CMOS technology so that your investment is protected, but they can easily be programmed with the old program numbers and programming voltage that were applicable to NMOS submodules if a special adapter is used.

EPROM submodules with the ordering code -1LAxx or -1Axx are equivalent to the new CMOS submodules and can be programmed on PUs with the new fast programming algorithms.

The memory submodules cover the range of the most common submodules. We can manufacture special submodules for individual customer requirements within a short time.

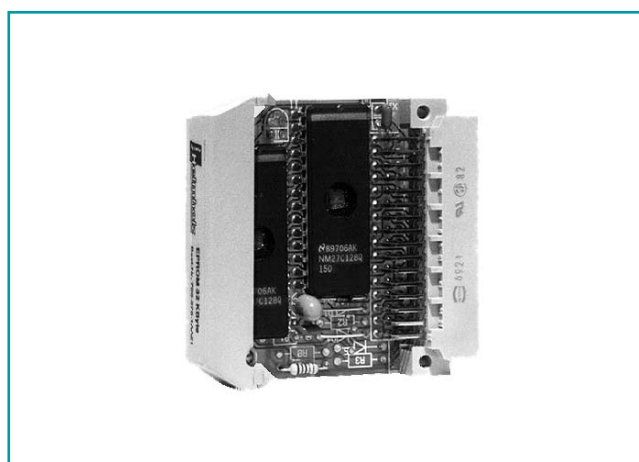

EPROM submodule 376

Ordering Data	Order No.
<b>EPROM submodules series 375</b>	
8 kByte	700-375-0LA15
16 kByte	700-375-0LA21
32 kByte	700-375-0LA41
64 kByte	700-375-0LA61
128 kByte	700-375-0LA71
8 kByte, with new CMOS submodules	700-375-1LA15
16 kByte, with new CMOS submodules	700-375-1LA21
32 kByte, with new CMOS submodules	700-375-1LA41
64 kByte, with new CMOS submodules	700-375-1LA61
128 kByte, with new CMOS submodules	700-375-1LA71
<b>EPROM submodules series 373</b>	
32 kByte	700-373-1AA41
64 kByte	700-373-1AA61
128 kByte	700-373-1AA81
<b>EEPROM submodules series 375</b>	
2 kByte	700-375-0LC11
4 kByte	700-375-0LC21
8 kByte	700-375-0LC31
16 kByte	700-375-0LC41
8/16 kByte	700-375-0LC45
<b>EPROM submodules series 376</b>	
16 kByte	700-376-1AA11
32 kByte	700-376-1AA21
64 kByte	700-376-1AA31

Technical Data	
<b>EPROM modules series 375</b>	
Memory capacity	8 kByte 16 kByte 32 kByte 64 kByte 128 kByte
Areas of application	PLC 95, PLC 100, PLC 115, CP 530
<b>EPROM modules series 376</b>	
Memory capacity	16 kByte 32 kByte
Areas of application	PLC 91351, IP 257
<b>EPROM modules series 373</b>	
Memory capacity	32 kByte 64 kByte 128 kByte
Areas of application	PLC 155, WF 470, CP 524, CP 525, CP 526, CP 527
<b>EEPROM modules series 375</b>	
Memory capacity	2 kByte 4 kByte 8 kByte 16 kByte 32 kByte
Areas of application	PLC 95, PLC 100, PLC 115, CP 530

1) The new version of the CPU 928B now only uses memory cards

## DEA 115, Digital Input/Output Modules



Digital input/output module

The digital input modules from the Systeme Helmholtz GmbH convert the external binary signals from the process into the internal signal level of the programmable controllers. The digital output modules convert the internal signal level of the programmable controllers into the external binary signal level required for the process. Green LEDs indicate the signal status of the inputs and outputs.

The signal lines are connected to the corresponding front connectors. You can identify them on the labeling strip next to the LEDs.

You can remove and insert the modules and front connectors during operation without damaging the modules.

Ordering Data	
	Order No.
<b>DEA 115</b>	
32 inputs (DC 24 V) non isolated	700-420-7LA11
32 inputs (DC 24 V) isolated	700-430-7LA12
<b>DEA 115</b>	
32 outputs (DC 24 V; 0,7 A) non isolated	700-441-7LA12
32 outputs (DC 24 V; 0,7 A) isolated	700-451-7LA12

## DEA 115, Digital Input/Output Modules

Technical Data		
	700-420-7LA11	700-430-7LA12
<b>Number of inputs</b>	32	32
<b>Isolation</b> • in groups of	No -	Yes 8
<b>Input voltage (nom. value)</b> • for "0" signal • for "1" signal	DC 24 V -33 to +5 V +13 to +33 V	DC 24 V -33 to +5 V +3 to +33 V
<b>Input current</b> • for "1" signal	typ. 8.9 mA	8.5 mA
Permiss. quiescent current for 2-wire Bero	min. 1.5 mA	1.5 mA
<b>Delay time<sup>1)</sup></b> • turn on • turn off	typ. 2.3 ms typ. 2.5 ms	2.3 ms 4.6 ms
<b>Cable length</b> • unshielded • shielded	max. 600 m max. 1000 m	600 m 1000 m
Front connector	46-way	46-way

Technical Data		
	700-441-7LA12	700-451-7LA12
<b>Number of outputs</b>	32	32
<b>Isolation</b> • in groups of	No -	Yes (optocoupler) 8
<b>Supply voltage <math>V_p, V_s</math></b> • nominal value • ripple $V_{pp}$ • permissible range (with ripple) • value at $t < 10$ ms	max. DC 24 V 3.6 V 20 to 30 V max. 50 V	DC 24 V 3.6 V 20 to 30 V 50 V
<b>Output current for "1" signal</b> • nominal value • permissible range • transient peak load ( $t=10$ ms, $d=20\%$ )	0.5 A 5 mA to 0.7 A max. 1.5 A	0.5 A 5 mA to 0.7 A 1.5 A
Lamp load (at nominal voltage)	max. 16.5 W	16.5 W
Inductive load	max. 0.2 H (at 0.7 A) 0.4 H (at 0.5 A) 1.1 H (at 0.3 A)	0.2 H (at 0.7 A) 0.4 H (at 0.5 A) 1.1 H (at 0.3 A)
Overload protection	Electronic	Electronic
Voltage induced on circuit interruption limited (internally) to	typ. $V_p - 50$ V	$V_p - 50$ V
<b>Switching frequency for</b> • resistive load • lamps • inductive load	max. 1 kHz max. 100 Hz max. 2 Hz (at 0.3 A/0.7 H) 1 Hz (at 0.5 A/0.4 H)	1 kHz 100 Hz 2 Hz (at 0.3 A/0.7 H) 1 Hz (at 0.5 A/0.4 H)
<b>Slope times</b> • turn on • turn off	typ. 0.13 ms typ. 0.05 ms	0.2 ms 0.06 ms
<b>Total load capability</b> • without fan at 55 °C • without fan at 35 °C • with fan at 55 °C	60% 100% 100%	60% 100% 100%
Residual current for "0" signal	max. 300 $\mu$ A	300 $\mu$ A
<b>Signal level of the outputs</b> • for "0" signal • for "1" signal	max. +2 V min. $U_p - 1,0$ V	+2 V $U_p - 1,0$ V

1) Other delay times on request

## DEA 135, Digital Input/Output Modules



Digital input module

The digital input modules from the Systeme Helmholtz GmbH convert the external binary signals from the process into the internal signal level of the programmable controllers. The digital output modules convert the internal signal level of the programmable controllers into the external binary signal level required for the process. Green LEDs indicate the signal status of the inputs and outputs.

Red LEDs indicate an overload or short-circuit of outputs. The alarm output H carries a "1" signal if an overload or short-circuit has been detected on an output. It is possible to connect up to 16 alarm outputs in parallel.

With an enable input F it is possible to suppress the output of signals. It is possible to deactivate this function by removing a jumper on the module.

The signal lines are connected to the corresponding front connectors. You can identify them on the labeling strip next to the LEDs. Labels are provided to identify the modules and front connectors.

You can remove and insert the modules and front connectors during operation without damaging the modules.

Ordering Data	
	Order No.
<b>DEA 135</b>	
32 inputs (DC 24 V) non-isolated	700-420-4UA14
32 inputs (DC 24 V) isolated	700-430-4UA14
<b>DEA 135</b>	
32 outputs (DC 24 V; 0,7 A) non-isolated	700-441-4UA14
32 outputs (DC 24 V; 0,7 A) isolated	700-451-4UA14

## DEA 135, Digital Input/Output Modules

Technical Data			
		700-420-4UA14	700-430-4UA14
<b>Number of inputs</b>		32	32
<b>Isolation</b> • in groups of		No -	Yes 32 <sup>1)</sup>
<b>Input voltage</b> (nom. value) • for "0" signal • for "1" signal		DC 24 V -33 to +5 V +13 to +33 V	DC 24 V -33 to +7 V +13 to +33 V
Permiss. quiescent current for 2-wire Bero	min.	1.5 mA	2.5 mA
<b>Delay time</b> <sup>2)</sup> • turn on • turn off		typ. typ.	2.3 ms 5.2 ms
<b>Cable length</b> • unshielded • shielded		max. max.	600 m 1000 m
<b>Enable input F</b> <b>Input voltage</b> (nom. value) • for enable • for disable		DC 24 V +13 to +33 V -33 to +5 V	DC 24 V +13 to +33 V -33 to +5 V
Input current of the F input	typ.	5 mA	5 mA

Technical Data			
		700-441-4UA14	700-451-4UA14
<b>Number of outputs</b>		32	32
<b>Isolation</b> • in groups of		No -	Yes (optocoupler) 32 <sup>3)</sup>
<b>Supply voltage <math>V_p</math>, <math>V_s</math></b> • nominal value • ripple $V_{pp}$ • permissible range (with ripple) • value at $t < 10$ ms		max.	DC 24 V 3.6 V 20 ... 30 V 50 V
<b>Output current for "1" signal</b> • nominal value • permissible range • transient peak load ( $t=10$ ms, $d=20\%$ )		max.	0.5 A 5 mA to 0.7 A 1.5 A
Lamp load (at nominal voltage)	max.	16.5 W	16.5 W
Inductive load	max.	0.2 H (at 0.7 A) 0.4 H (at 0.5 A) 1.1 H (at 0.3 A)	0.2 H (at 0.7 A) 0.4 H (at 0.5 A) 1.1 H (at 0.3 A)
Overload protection		Electronic	Electronic
Voltage induced on circuit interruption limited (internally) to	typ.	$V_p - 50$ V	$U_p - 50$ V
<b>Switching frequency for</b> • resistive load • lamps • inductive load		max. max. max.	1 kHz 100 Hz 2 Hz (at 0.3 A/0.7 H) 1 Hz (at 0.5 A/0.4 H)
<b>Total load capability</b> • without fan at 55 °C • without fan at 35 °C • with fan at 55 °C			60% 100% 100%
Residual current for "0" signal	max.	300 $\mu$ A	300 $\mu$ A
<b>Signal level of the outputs</b> • for "0" signal • for "1" signal		max. min.	+2 V $U_p - 1.0$ V

1) Other groupings on request

2) Other delay times on request

3) Insulation in 2 groups of 16 on request

## AEA 115, Analog Input Modules



Analog input module

The analog input modules from the Systeme Helmholtz GmbH convert the analog signals from the process to the internal signal level of the programmable controllers. The signal lines are connected to the corresponding front connectors. You can identify them on the labeling strip.

Ordering Data	
	Order No.
<b>AEA 115</b> 16 voltage/current inputs or 8 Pt100 resistance thermometer non-isolated	700-465-7LA13
<b>Meas. range subm. 498 for AEA 115</b> ±50 mV/±500 mV/Pt100 ±100 mV/±1 V ±1 V/±10 V ±2 mA/±20 mA 4 ... 20 mA; 2-wire ±500 mV/±5 V 4 ... 20 mA; 4-wire	700-498-1AA11 700-498-1AA21 700-498-1AA31 700-498-1AA41 700-498-1AA51 700-498-1AA61 700-498-1AA71

Technical Data	
<b>Number of inputs</b>	16 voltage/current inputs, 8 Pt100 resistance thermometers
Isolation	No
Permissible voltage between reference potential of a sensor and a central grounding point	max. ±1 V
Nominal input value	Selectable for 4 chan. with meas. range submodules, see ordering data meas. range subm.
Digital representation of the input signal	12 Bits + sign or 13 Bits two's complement
<b>Input resistance</b> Depending on meas. range submodule	min.
700-498-1AA11	10 MΩ
700-498-1AA21	90 kΩ
700-498-1AA31, 700-498-1AA61	50 kΩ
700-498-1AA51, 700-498-1AA71	31.25 Ω
700-498-1AA41	25 Ω
<b>Basic error limits</b> ±50 mV/Pt100 ±500 mV ±1 V/±5 V/±10 V ±20 mA/+ 4 to 20 mA	±2 ‰ ±1.5 ‰ ±3.5 ‰ ±2.5 ‰
<b>Basic error limits</b> ±50 mV/Pt100 ±500 mV ±1 V/±5 V/±10 V ±20 mA/+ 4 to 20 mA	(0 °C to +55 °C) ±5 ‰ ±4,5 ‰ ±7.7 ‰ ±6.7 ‰
Conversion time (settable)	20 ms for 50 Hz 16.6 ms for 60 Hz
<b>Supply voltage</b> • nom. value	DC 24 V
<b>Current consumption</b> • internal (at 5 V) • external (at 24 V)	typ. 200 mA typ. 20 mA/transducer
<b>Cable length</b> • shielded	max. 200 m max. 20 m / 50 mV
Power loss (rated operation)	typ. 1.0 W
Space requirement	1 slot
Front connector	46-way
Ambient temperature Transport and storage temperature	0 °C ... +55 °C -25 °C ... +75 °C

## AEA 115, Analog Output Modules



Analog output module

The analog output modules from the Systeme Helmholtz GmbH convert the internal signal level of the programmable controllers to the analog signal level required for the process. The signal lines are connected to the corresponding front connectors. You can identify them on the labeling strip.

Ordering Data	
	Order No.
<b>AEA 115</b> isolated 8 outputs, $\pm 10$ V/0 to 20 mA	<b>700-470-7LA13</b>
8 outputs, $\pm 10$ V	<b>700-470-7LB13</b>
8 outputs, + 1 to 5 V/4 to 20 mA	<b>700-470-7LC13</b>

Technical Data			
	700-470-7LA13	700-470-7LB13	700-470-7LC13
<b>Number of outputs</b>	<b>8</b>	<b>8</b>	<b>8</b>
<b>Isolation</b> • in groups of All outputs referenced to $M_{ANA}$	Yes (optocoupler) 8	Yes (optocoupler) 8	Yes (optocoupler) 8
<b>Nominal output value</b> • voltage • current	$\pm 10$ V/min. 3.3 k $\Omega$ 0 ... 20 mA/max. 300 $\Omega$	$\pm 10$ V/min. 3.3 k $\Omega$ -	1 ... 5 V/min. 3.3 k $\Omega$ 4 ... 20 mA/max. 300 $\Omega$
Overload protection	Yes	Yes	Yes
Digital representation of the output signals	11 Bits + sign	11 Bits + sign	11 Bits + sign
Linearity of the nom. range	$\pm 2.5$ ‰	$\pm 2.5$ ‰	$\pm 2.5$ ‰
Operational limits (0 °C to +55 °C)	$\pm 6$ ‰	$\pm 6$ ‰	$\pm 6$ ‰
Supply voltage L+	DC 24 V	DC 24 V	DC 24 V
<b>Cable length</b> • shielded	max. 200 m	200 m	200 m
<b>Current consumption</b> • internal (at 5 V) • external (at 24 V, without load)	typ. 300 mA typ. 350 mA	300 mA 350 mA	300 mA 350 mA
Power loss (rated operation)	typ. 10 W	10 W	10 W
Space requirement	1 slot	1 slot	1 slot
Front connector	46-way	46-way	46-way
Ambient temperature Transport and storage temperature	0 °C ... +55 °C -25 °C ... +75 °C	0 °C ... +55 °C -25 °C ... +75 °C	0 °C ... +55 °C -25 °C ... +75 °C



## SAS 523/525, Serial Interface Modules

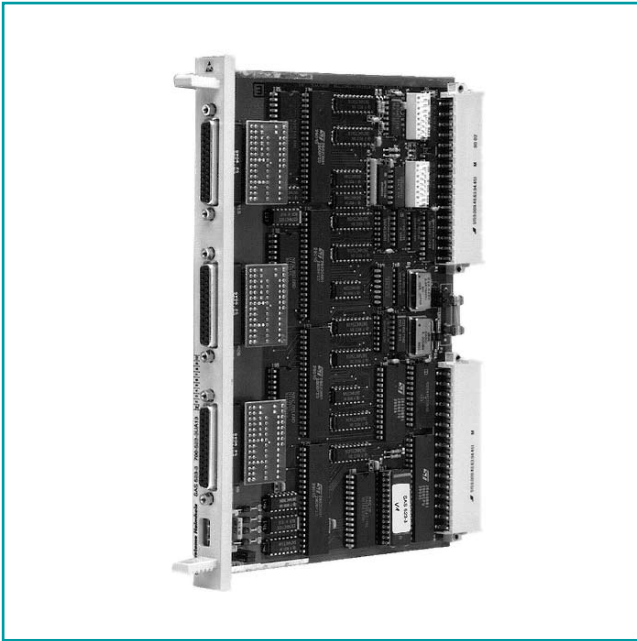

SAS 523 interface module

The SAS 523/525 communication processors from the Systeme Helmholtz GmbH are for linking programmable controllers with other items of equipment with a serial interface.

The SAS 525 not only has an open driver but also the 3964/3964R procedure with RK512 frame structure.

You can connect, for example printers, personal computers, barcode readers, weighing machines, terminals, keyboards, or other process peripherals that have a serial interface and in the case of the SAS 525, all devices that use the RK512 computer link.

The SAS 523-3/525-3 has three serial interfaces.

The modules can be used in PLCs (without a fan tier) in the central controller or expansion unit and in the IM slot. A CP slot is not required.

If you are using the open driver and if you have implemented bus transmission, the modules can buffer 255 bytes per channel and direction of data flow, handle the serial communication actively and therefore off-load the CPU.

Ordering Data	
	Order No.
<b>Serial interface</b> SAS 523-3	700-523-3UA13
<b>Serial interface</b> SAS 525-3	700-525-3UA13
<b>Interface modules SAS 523/525</b> TTY	700-523-1UA11
RS232	700-523-1UA21
<b>Manual SAS 523/525</b> German/English	900-523-0AA11
<b>Data handling blocks for SAS 523</b> on data storage media PLC 115 ... PLC 155	802-523-1AA61
<b>Data handling blocks SAS 525</b> on data storage media PLC 115 ... PLC 155	802-525-1AA61

The open transmission protocol of the SAS 525 is the same as that of the SAS 523. In addition a driver can be initialized for the RK512 protocol.

Data exchange with the programmable controller is executed by function blocks (data handling blocks), which are parameterized by the user.

#### Programming

It is not necessary to program the modules. They are parameterized using DIL switches and data handling blocks for initializing the modules.

#### Interface

The interface is suitable for transmission of

- 20 mA current-loop signals (TTY)
- RS232.

It is configured by plugging in an interface submodule. The transmission rate can be set separately between 150 Bps and 38400 Bps for each channel.

#### Note

Please also order the appropriate interface submodule for each interface.

Technical Data	
Supply voltage	+5 V $\pm$ 5%
<b>Current consumption</b>	
• SAS 523-3/525-3	460 mA
• TTY submodule additionally, if active	10 mA
• RS232 submodule	40 mA / 24 V 10 mA
Transmission mode	Serial asynchronous
Transmission rate	150 to 38400 Bps
Parity	Even, odd, none
Data format	7 or 8 Bits
Handshake	RTS, CTS (RS232) break (TTY) bus (RS422/485)
Supported protocols for SAS 523	ASCII
Supported protocols for SAS 525	ASCII, RK512
Connector	SUB-D, 25-way
Max. cable length	
TTY	1000 m
RS232	16 m



# Service

Individual Developments  
Training Courses

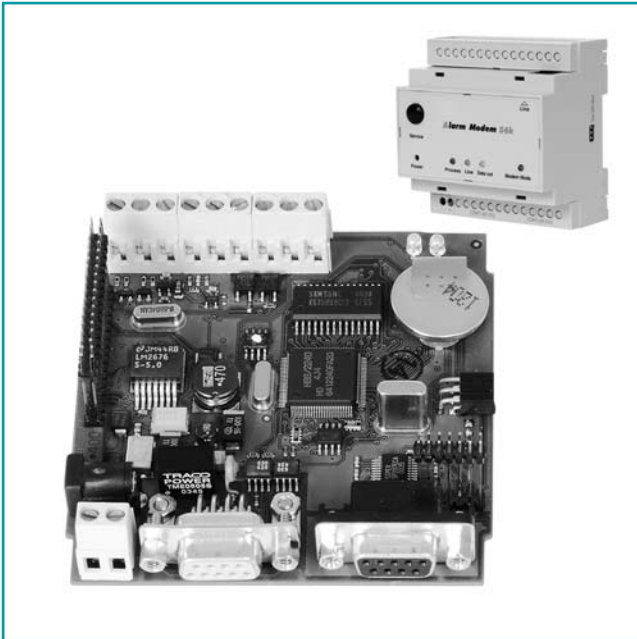

Customer-specific MPI board

Systeme Helmholz is your supportive partner for individual hardware and software development. Years of experience in the development and manufacture of electronic components and comprehensive know-how in automation enable us to find a tailored solution for your requirements.

**We can offer you the following services:**

- Creation of specifications and costing
- Complete development of the hardware and software
- Mechanical design of the housing
- Tool design for injection molding tools
- Operating system development
- Software for parameterizing under Microsoft Windows
- CE conformity tests
- Projecting and building of test equipment

Compliance with the general guidelines for quality assurance and the valid EMC regulations is already ensured during development.

Moreover, we are able to conduct the series production of your products. The products are manufactured, tested and delivered according to ISO 9001:2000.

With our modern and flexible development and manufacturing capacity we are able to implement small to medium-sized projects very quickly.

**Examples of customer-specific applications hardware:**

- Special variants DEA 300
- MPI-PROFIBUS Gateways for customer-specific protocols
- Operating units for building technologies

**Software:**

- CANopen® Slave handling block
- Special protocols for linking customer-specific devices to PLC
- Production data acquisition and evaluation in a network environment under Windows
- Application development for Windows 9x/ME/200 with Borland Builder, C++ or Borland Delphi

## Training Courses, PROFIBUS Service

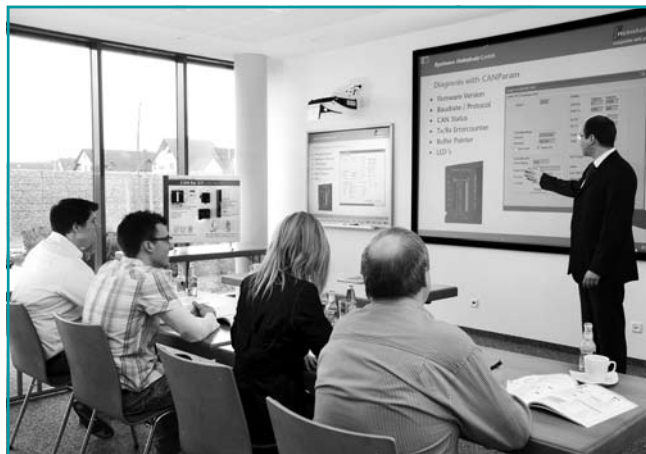

The Systeme Helmholtz GmbH also offers product training for:

- CAN Bus
- S7 Teleservice/Teleservice/Router
- NETLink® and OPC-server

The trainers will teach you all you need to know about correct handling of products by way of practical examples.

Make an appointment with one of our specialists for your own in-depth consultation.

Please request your individual offer!

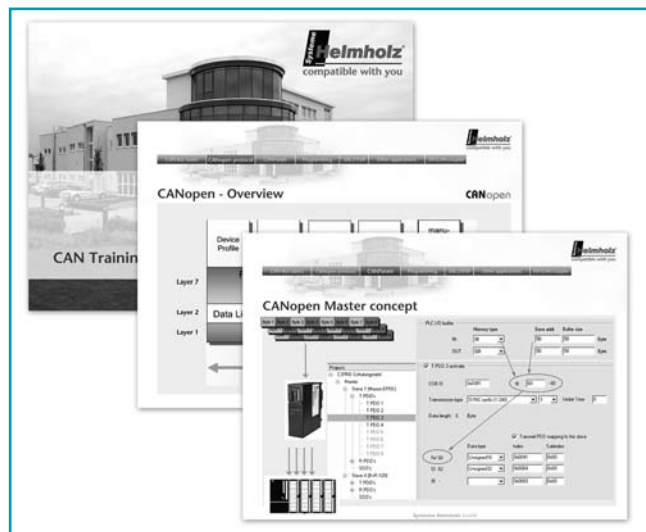

### CAN Training Course

#### Contents:

- CAN concept
- CAN Layer 2 protocol
- CANopen® protocol
- CAN 300/CAN 400 parameterization & start-up
- CAN 300/CAN 400 programming in STEP<sup>1)</sup> 7
- DP/CAN Coupler

### PROFIBUS Service

Your new service provider for field bus systems.

The transmission quality of field bus systems is a basic requirement for stably running machines and plants. Ever more complex applications and ever greater volumes of data can be transmitted quickly and reliably. We want to help you!

Systeme Helmholtz GmbH offers not only a broad range of products for the PROFIBUS and CAN bus but also, with immediate effect, the following services connected with the field bus systems:

- Troubleshooting
- Diagnostics
- Planning support
- Seminars

The aim is to implement your individual requirements in cooperation with you.

Please request your individual offer!

#### Ordering Data

	Order No.
Training Course CAN/CANopen®/CAN products, 1 day	400-600-CAN01

1) STEP is a registered trademark of Siemens AG



## Contacts in Germany

**Distribution North Germany****Holster Industrieelektronik GmbH**

Fasanenstieg 14  
22397 Hamburg  
Thomas D. Holster  
Phone: +49 (40) 605 18 18  
Fax: +49 (40) 605 55 93  
thomas.holster@helmholz.de

**Distribution East Germany****B-S-K Industrievertretungen**

Holz-mühlen-strasse 4  
09212 Limbach-Oberfrohna  
Siegfried Renner  
Phone: +49 (376 09) 583 55  
Fax: +49 (376 09) 583 56  
siegfried.renner@helmholz.de

**Distribution Baden-Württemberg****Systeme Helmholz GmbH**

Hannberger Weg 2  
91091 Großenseebach  
Timo Stegmüller  
Phone: +49 (91 35) 73 80-0  
Fax: +49 (91 35) 73 80-110  
timo.stegmueller@helmholz.de

**Headquarters****Systeme Helmholz GmbH**

Hannberger Weg 2  
91091 Großenseebach  
Karsten Eichmüller  
Phone: +49 (91 35) 73 80-0  
Fax: +49 (91 35) 73 80-110  
karsten.eichmueller@helmholz.de

**Distribution Bavaria****Systeme Helmholz GmbH**

Hannberger Weg 2  
91091 Großenseebach  
Martin Fröhlich  
Phone: +49 (91 35) 73 80-0  
Fax: +49 (91 35) 73 80-110  
martin.froehlich@helmholz.de

**Distribution West Germany****Systeme Helmholz GmbH**

Hannberger Weg 2  
91091 Großenseebach  
Martin Güll  
Phone: +49 (91 35) 73 80-0  
Fax: +49 (91 35) 73 80-110  
martin.guell@helmholz.de

**H-I Elektronik Vertrieb GmbH**

Düsseldorfer Straße 547  
47055 Duisburg  
Thomas Dohmen  
Stephan Schmücker  
Phone: +49 (203) 76 14 03  
Fax: +49 (203) 76 44 00  
vertrieb@h-i-elektronik.de  
www.h-i-elektronik.de

The **Systeme Helmholtz GmbH** is present in the following countries:

	Austria		Netherlands
	Australia		Norway
	Belgium		Poland
	Brazil		Portugal
	Bulgaria		Romania
	Chile		Singapore
	China		Slovakia
	Croatia		Slovenia
	Czech Republic		South Africa
	Denmark		South Korea
	Egypt		Spain
	Finland		Sweden
	France		Switzerland
	Hungary		Taiwan
	India		Thailand
	Ireland		Turkey
	Israel		United Arab Emirates
	Italy		U.S.A.
	Malaysia		United Kingdom

Please find the contact details of our sales partner on our homepage [www.helmholz.com](http://www.helmholz.com).

Your Salespartner



**Systeme Helmholz GmbH** | Hannberger Weg 2 | 91091 Großenseebach

Phone: +49 9135 7380-0 | Fax: +49 9135 7380-110

E-Mail: [info@helmholz.de](mailto:info@helmholz.de) | Internet: [www.helmholz.com](http://www.helmholz.com)

11/2010