

WE MADE OUR DECISION!

**ELECTRONIC CAM CONTROLS MADE
BY DEUTSCHMANN**



LOCON ROTARNOCK

**DEUTSCHMANN – Your partner
for fast switching and industrial communication**

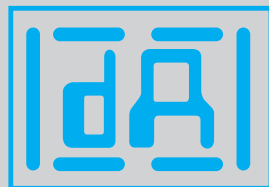

Deuschmann Automation



- *Development and production of electronic cam controls since 1982.*
- *Since 1990 the brand names LOCON and ROTARNOCK stand for reliable and fast electronic cam controls.*
- *LOCON – The classic concept of separate control and separate actual-value acquisition.*
- *ROTARNOCK – The intelligent solution: Electronic cam controls and actual-value acquisition combined in one housing.*
- *We do not rest and we are steadily working on the further development of the products and the expansion of our product range. So new models have been created in order to adapt the LOCON- and ROTARNOCK-series to the current market requirements. We were particularly inspired by the implementation of the the Fieldbus accessibility combined with modern control- and configuration-concepts.*



LOCON 200

*Fast
and modular*

LOCON 200 consists of a basic unit with the tasks of the central actual-value acquisition, communication with the periphery, voltage supply and some further administration topics.

The complete performance capability is achieved by using the expansion modules with 8 I/Os each.

Through the consistent rendering as I/Os the basic module as well as the expansion unit achieves the highest possible flexibility and best possible utilization of the hardware.

If, for instance only 8 externally selectable programs are required, the otherwise usual reserved pins are not wasted but can be used in another way.

The system is limited to one basic unit and max. 16 I/O-modules. Through the use of a separate processor for each module the cycle time in the overall system remains constant and depends upon configuration, encoder type, resolution as well as used software-performance characteristics. All modern actual-value acquisition systems from incremental to multiturn encoder are supported.

The connection to Fieldbus systems is just as much a matter of course as the configuration via a PC-program that is to be operated intuitively. The alternative operation through an external terminal or the complete integration in the Fieldbuses come naturally with us. A version with integrated ProfibusDP is optionally available.

Expansion module I/O8

With this module LOCON 200 is expanded by 8 I/Os up to the maximum configuration level of 144 I/Os step-by-step.

The expansion module contains its own processor. Therefore, the switching accuracy (cycle time) is independent of the LOCON 200(-PB) basic module or in other words: the configuration-dependent cycle time remains the same independent of the configuration level.

In the I/O8, the idle time can be configured in a module-related way. Besides, the device supports logic functions. That way logic connections can be realized in a module-related manner.

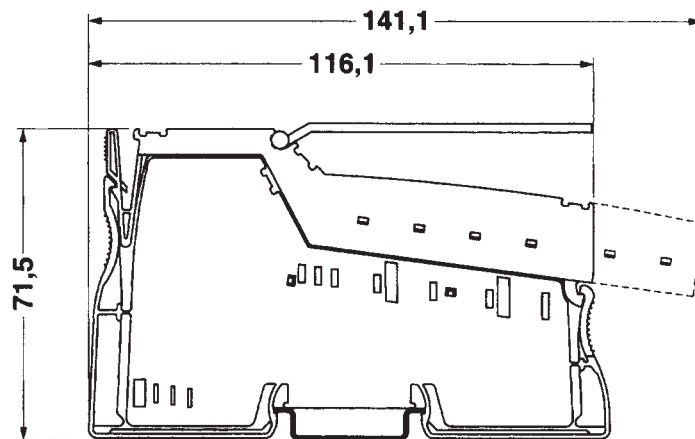
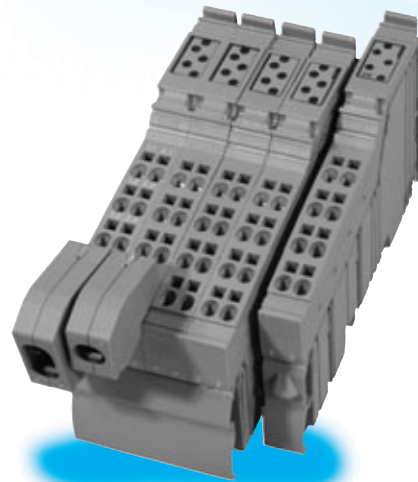

LOCON 200

Construction width: Basic device 48.8 mm,
expansion module 12.2 mm



LOCON 100

*Powerful
and expandable*

LOCON 100 consists of a basic unit with a total of 16 I/Os. They can be configured depending on the respective application. If, for instance, you require a 9-bit encoder only, other encoder connections are not wasted but can be put to practical use for other applications.

The system can be expanded by one module to a total of 48 I/Os which are configured in the same way. So you can set up your cam control individually and you are totally free regarding outputs, inputs, logic connection and utilization of functions such as external program selection, encoder type and resolution etc.

LOCON 100 also features connection facilities for all modern actual-value acquisition systems. The software gives you the freedom to choose from various types of idle time compensation (dynamic cam). No matter whether angle-/angle-cams or angle-/time-cams are used – everything can be configured and combined.

The modern control-concept is convincing and offers something for all tastes: Modern PC GUI, that can be connected to any Fieldbus or the easy-to-handle terminal GUI. The device with integrated ProfibusDP is optionally available.

Expansion module I/O32

With this module the basic device LOCON 100(-PB) is expanded by 32 to a total of 48 I/Os.

The expansion module does not contain an own processor. Therefore, the switching accuracy (cycle time) depends on the LOCON 100(-PB), its configuration and programmed data records.

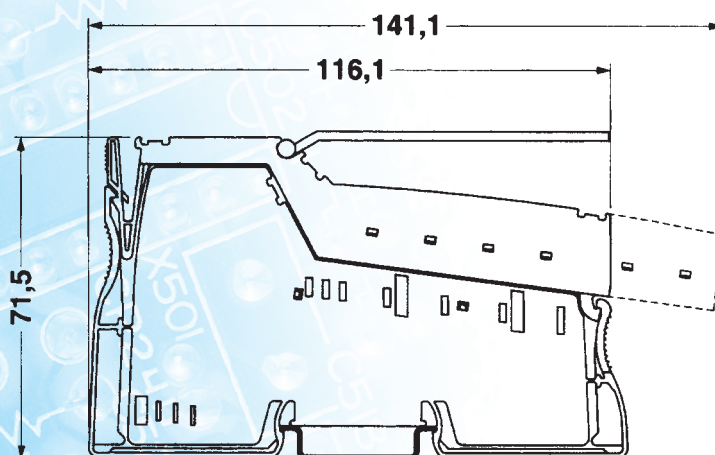
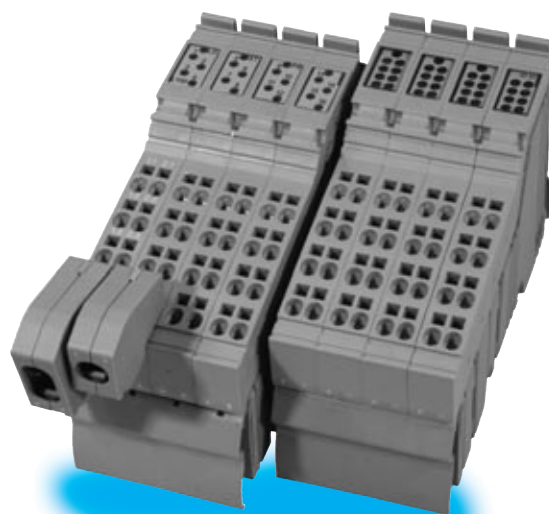

LOCON 100

Construction width: Basic device 48.8 mm, expansion module 48.8 mm

LOCON 24, 48, 64

The multifunctionals

Compact series with DIN size of 144 x 144 mm. With an overall depth of only 44 mm, LOCON 24 features 24 or 32 outputs, LOCON 48 has 48 outputs available and LOCON 64 features 64 outputs, 64 programs that can be selected via the integrated operation front panel or that can be selected externally. A memory of 1000 data records as well as an extensive range of functions round off the range of services.

The version with integrated operation front panel for front panel installation (either IP54 or IP65) offers the operating convenience you are looking for nowadays: Seven-segment display for position and speed indication, 2-line LCD with 10-multi-lingual, user-configurable menu, and both, a decimal keypad and a function keypad.

The position recording at this model-series can be carried out either with incremental encoders, absolute encoders parallel up to 13 bits and with SSI-systems 24 bits. Here it does not make a difference whether it is a rotary encoder or for instance a linear measuring system.

Optionally, LOCON 24 is available with 16 inputs for logic connections (simple PLC-function). This allows simple tasks to be relocated from the PLC to the cam control, thus performing these tasks much faster or enable-functions can be realized easily at a lower cost. Further this performance characteristic includes a shift register

Furthermore the following options are available for this series:

- Angle-time cams
- Analog outputs

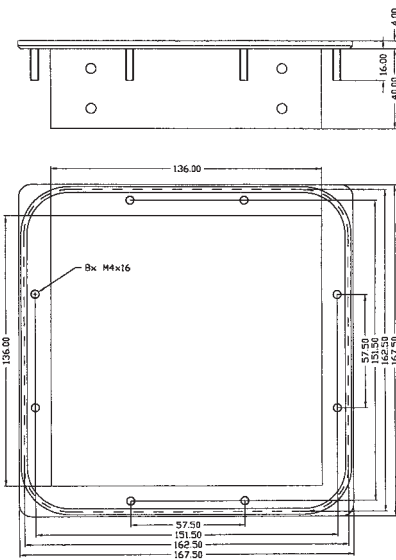

LOCON 24, 48, 64 with front plate IP65

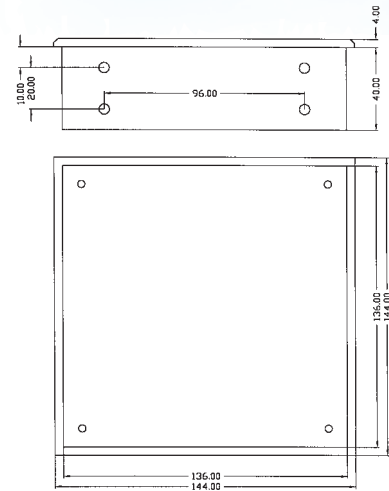

LOCON 24, 48, 64 with front plate IP54

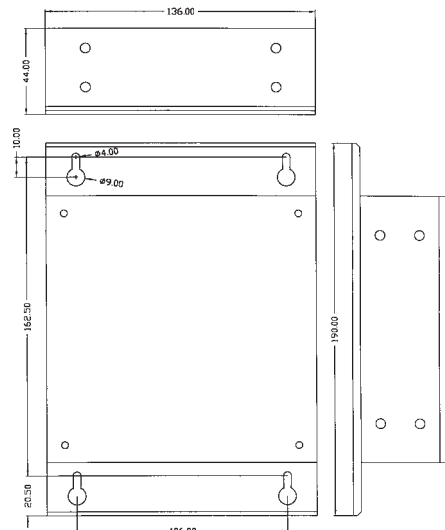

LOCON 24, 48, 64 PM for mounting plate



LOCON 16, LOCON 17

*Versatile and
compact*

The compact solution with DIN size of 72 x 96 mm (W x H) and an overall depth of only 70 mm. With integrated operating unit the device is mounted in the front plate, the version without keypad is mounted on a DIN-rail.

The "four-key operator interface" has proven its worth in thousands of applications and can be operated easily after a brief training period. 16 outputs, 16 programs, blockwise and bitwise idle time compensation are available as standard in the basic unit.

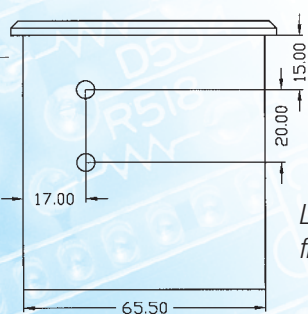
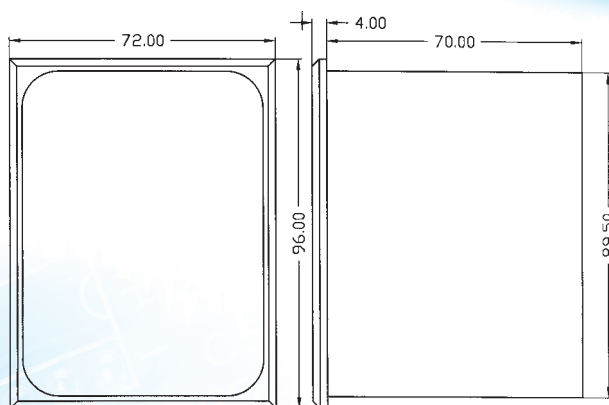

*LOCON 16, 17 with
front plate IP65*

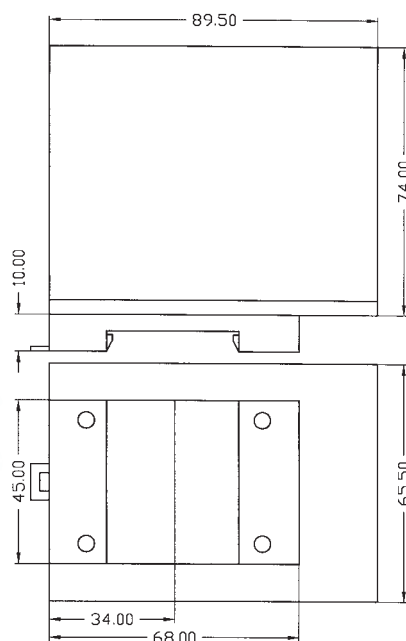

LOCON 16, 17 PM for DIN-rail

The ROTARNOCK-family



With the ROTARNOCK-series Deuschmann Automation took a new innovative path. The entire cam control was integrated in the housing of the absolute encoder. This saves work and money. The wiring of the encoder can be dispensed with entirely. The outputs of the cam control are applied directly to the device via its connector.

The devices ROTARNOCK 80 and 100 are available with integrated Profibus-interface. The device versions with Profibus can be connected easily to SIEMENS SIMATIC S7 and other PLCs and Soft-PLCs.

The data exchange between the PLC and the cam control is carried out via a data component. The data component for S7 can be generated by the user himself by means of the data component generator that is available free of charge. A data component in the version required in each case is generated by the data component generator, so that no unnecessary storage space is occupied in the PLC. The handling components needed for an S7-Profibus-connection are made available by Deuschmann free of charge. With it no programming effort is involved for the user and he does not have to carry out changes in the PLC-program. For the initial programming the comfortable PC-software WINLOC® can be used and the already fixed data component including cams, idle times etc. can be generated automatically.

The ROTARNOCK models are, of course, equipped to meet the demands of various industrial environments. The devices you can choose from are IP54-version with D-SUB connector or IP65-version with round plug.

■ ROTARNOCK 100

Our latest software package was implemented in this high-end-model. Thus a free software configuration is available. There are also innovations regarding the hardware. The switching outputs are highly loadable with 700 mA and reduce additional costs in the switch cabinet. After all the ROTARNOCK series is already economical by nature:

Complete equipment for all applications

The wiring effort is reduced since no additional rotary encoder has to be wired up. And the Profibus-version ROTARNOCK 100 unfolds its cost advantages even more.

■ ROTARNOCK 80

Our standard model for the normal application. Due to its resolution of 360 inf./rev., 8 switching outputs and bitwise idle time

Low-cost, but only when it comes to the price

compensation this unit can be used for many applications. But "Standard" does not mean second best. ROTARNOCK 80 also has a modern control concept: As an alternative it offers a comfortable PC GUI or a fully integrated ProfibusDP or you decide on one of the powerful Deuschmann terminals.

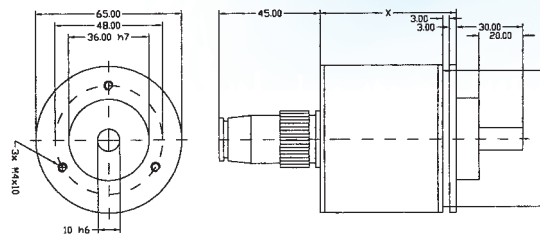

ROTARNOCK 80/100 with integrated Profibus or MPI, protection type IP65

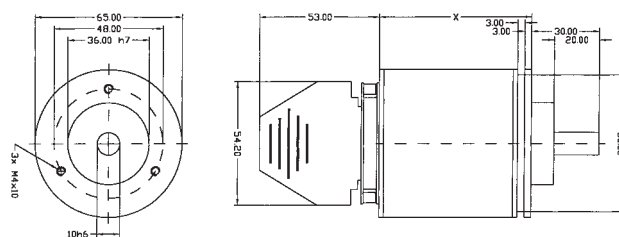

ROTARNOCK RS232 or RS485, protection type IP54

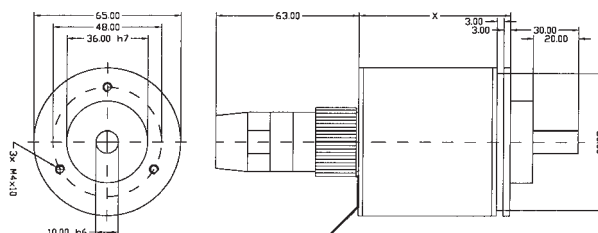

ROTARNOCK RS232 or RS485, protection type IP65

■ Profibus-connection



The devices ROTARNOCK 80 and 100 as well as the devices LOCON 100 and 200 are available with integrated Profibus-interface. The device versions with Profibus can be connected easily to SIEMENS SIMATIC S7 and other PLCs and Soft-PLCs. The data exchange between the PLC and the cam control is carried out via a data component. The data component for S7 can be generated by the user himself by means of the data component generator that is available free of charge. A data component in the version required in each case is generated by the data component generator, so that no unnecessary storage space is occupied in the PLC.

The handling components needed for an S7-Profibus-connection are made available by Deutschmann free of charge. With it no programming effort is involved for the user and he does not have to carry out changes in the PLC-program.

For the initial programming the comfortable PC-software WINLOC® can be used and the already fixed data component including cams, idle times etc. can be generated automatically.

WINLOC®

■ Programming Deutschmann cam controls under Windows

WINLOC® offers an easy to use graphical user interface for programming Deutschmann cam controls under Microsoft Windows 3.1x, 95, 98, Windows NT and Windows 2000/XP.

By simply entering a license number the basic version is upgraded to a comfort version with an interface that is easier to use and an extended printout capability.

The user may print all device data as complete documentation. The compilation of the data is made by the user. The printout is prepared as a scaleable preview, which can be observed before it is printed on paper.

WINLOC® is not restricted to one language. The user has the possibility to define a new one or to process an already existing language. The software is adjusted to the new language at the click of a button. German and English user guides are also a part of the range of services.

With the basic version WINLOC® already offers all necessary abilities for programming devices as well as for transferring data from Deutschmann cam controls to the PC.

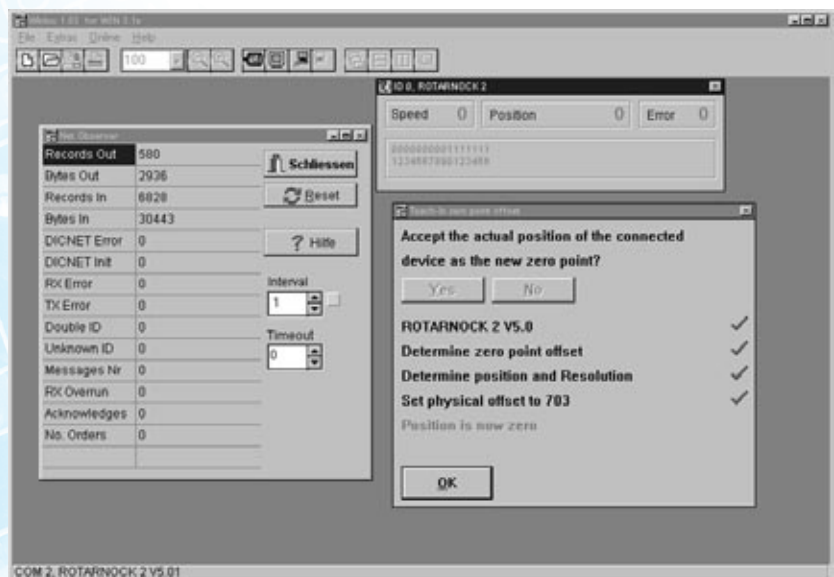

DB generator

■ PC-software data component generator

In a simple manner the program makes it possible to generate an AWL source file. Due to the clear arrangement of the component options they can be entered fast and easily. By means of these settings the program generates the AWL source

file. On the basis of a configuration file the program receives information on parameters and the size of this component. While initializing the program this file is read. It is also possible to read this file at a later time again.

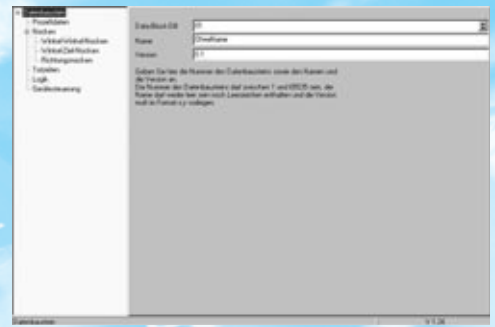

■ Generating the S7®-program code – fast and easy

After the program has been started, you can navigate through the setting options by means of the survey on the left side. On the individual parameter cards you can

set the parameter values, such as number of cams to be used as well as the cam type.

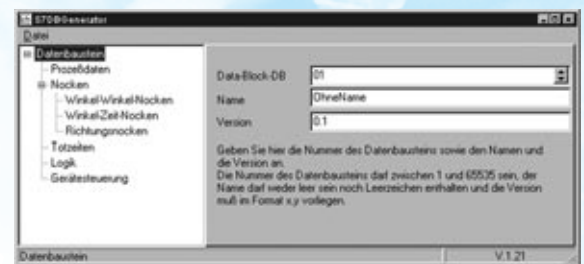

■ Generating the component through WINLOC® elegantly

If the data component generator is started from the WINLOC®-software, then the data, created in WINLOC® (cams, programs, idle times, configuration etc.) will automatically be assigned to the data component. By means of the corresponding settings

in the window of the DB generator it is also possible to create “reserves” for programs, cams, idle times etc. that are to be collected later.

■ Quick info

	LOCON 200	LOCON 100	LOCON 24, 48, 64	LOCON 16	LOCON 17	ROTARNOCK 80	ROTARNOCK 100
Outputs	16 I/Os, expandable by 8 each to max. 144	16 I/Os, expandable to 48	24 or 48 or 64	16	16	8	16 in hardware (at RS232 and DICNET) 16 hardware- + 32 software-outputs (with Profibus-version)
Idle time compensation	All versions can be configured freely		Bit- or blockwise	Blockwise	Bit- or blockwise	Bitwise	All versions can be configured freely
Installation	Din-rail module		Front panel installation or mounting plate	Front panel installation or Din-rail version		Integrated in an encoder housing version	
Actual-value acquisition	SSI-ST to 13 bits, SSI-MT to 25 bits, absolute encoder parallel to 13 bits, incremental 5V (422) or 24V		SSI-ST to 13 bits, SSI-MT to 24 bits, absolute encoder parallel to 13 bits, incremental 24V	SSI-ST 10 bits, absolute encoder parallel 360° or 1000 inf./rev., incremental 24V	SSI-ST to 12 bits, absolute encoder parallel to 12 bits, incremental 24V	360 inf./rev.	4096 inf./rev. freely scalable
Cycle time	Dynamic from 56 µs on	Dynamic from 100 µs on	From 100 µs on	From 500 µs on	From 150 µs on	From 500 µs on	Dynamic from 100 µs on
Miscellaneous	Optional with integrated Profibus-interface			RS232 and RS485 (switchable)	RS232 and RS485 (switchable)	Optional with integrated Profibus-interface	Optional with integrated Profibus- or DICNET-interface



Display and control units

■ TERM 6 – The small ones

The “four-key operation” which has proven its worth over the years in countless applications can be operated easily after a short familiarization period only. A clear structure and practical symbols on the seven-segment display, in conjunction with the function LEDs, made this interface very popular. The integrated and switchable RS232- and RS485-interfaces allow communication with any Deutschmann cam control. Besides the version for front-panel installation, also a version for DIN-rail mounting and a portable version for the service technician are available.

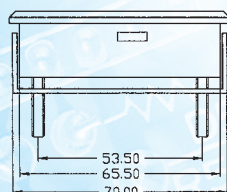
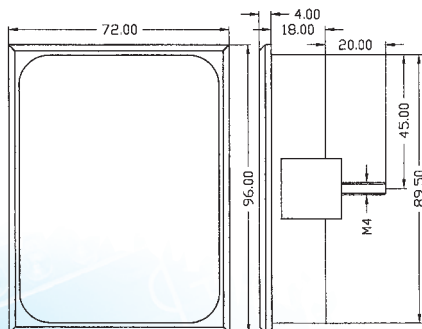

*TERM 6
for front-panel
installation*

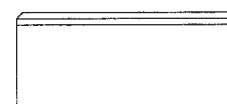
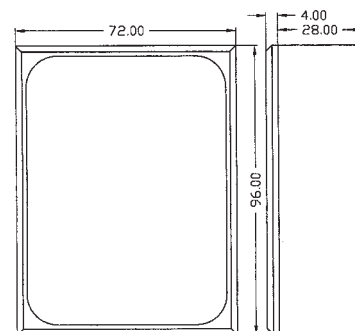

*TERM 6 T
portable terminal*

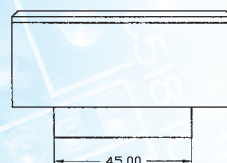
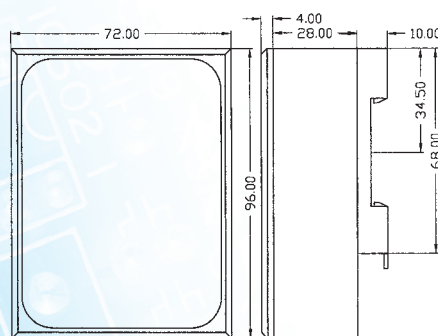

*TERM 6 H
for DIN-rail
mounting*

BY the name TERM 5, TERM 5 H and TERM 5 T the previous version is still available. This version, however, is not supposed to be used for new projects.

■ TERM 24 – The compact ones

This multi-lingual menu driven user-interface in connection with the decimal keypad and the function keys offers a high level of convenience. Encoder position and speed are displayed simultaneously on the seven-segment display. Depending on the kind of application, you can choose between the housing versions IP54 and IP65. This terminal can be used with any Deutschmann cam control thanks to the RS232- or RS485-interface

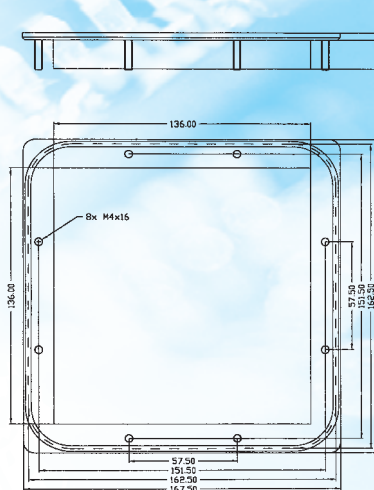

TERM 24 front plate IP65

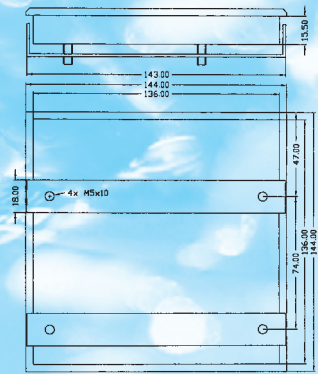

TERM 24 front plate IP54

■ Dynamic switching accelerator SPEEDY

Switching on and off magnetic controlled connect elements lead to delays that consist of two components:

- Delay time for setting up and removing the magnetic field
- Delay time for overcoming mechanical inertia

To reduce this delay time SPEEDY makes it possible to achieve an overexcitation of the magnetic field by a short duration over-voltage pulse, adjustable from 1 ms to 10 ms and with it to overcome the mechanical inertia much faster.

When switching off, the delay time for the removal of the magnetic field is also reduced considerably due to a negative free wheeling voltage.

The status of the inputs and outputs as well as of the supply voltages are displayed via integrated LEDs.

SPEEDY has different switching modes available that can be adjusted from the outside.

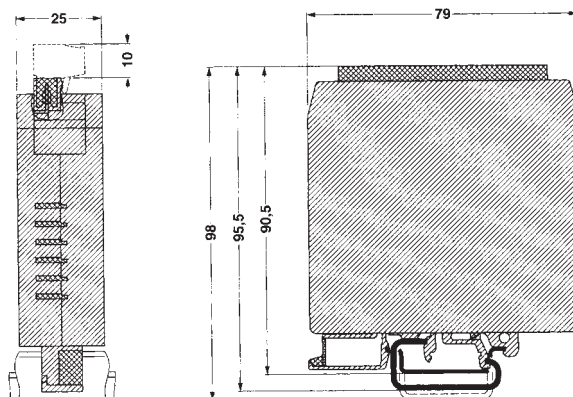

Deutschmann – Your partner for cam controls and Fieldbus technology worldwide.
On our website www.deutschmann.de you can find the current information on our products, complementary technical details, instruction manuals for download, Firmware updates as well as our – mostly free of charge – software tools.

Technical changes are subject to change. We do not accept any liability for print errors and mistakes.

Deutschmann Automation
GmbH & Co. KG



P.O. box 1108 · D-65516 Bad Camberg · Phone +49 (0) 64 34/94 33-0 · Fax +49 (0) 64 34/94 33-40 · E-Mail: info@deutschmann.de · www.deutschmann.de

AUDIN - 8, avenue de la malle - 51370 Saint Brice Courcelles - Tel : 03.26.04.20.21 - Fax : 03.26.04.28.20 - Web : <http://www.audin.fr> - Email : info@audin.fr